

Figure 1

1. INTRODUCTION

AMP* 2mm CT Head Assembly 58372-1, shown in Figure 1, is designed to terminate 2mm CT connector assemblies (listed in Figure 1) onto unstripped discrete wire size 28 through 26 AWG with an insulation diameter of 0.85-1.05 mm [.033-.041 in.].

The head is designed for use in AMP Pistol Grip Manual Handle Assembly 58074-1 (408-6790), Pistol Grip Pneumatic Handle Assembly 58075-1 (408-6789), or Pneumatic Power Bench Assembly 58338-1 (408-9393). For head installation procedures, and setup and operation of the tools, refer to the AMP instruction sheets (shown in parenthesis) packaged with the tool.

NOTE Dimensions on this sheet are in metric units [with U.S. customary units in brackets]. Figures are not drawn to scale.

Reasons for reissue of this instruction sheet are provided in Section 9, REVISION SUMMARY.

2. DESCRIPTION

The head assembly, when properly inserted into the tool, serves as a guide for the connector during termination.

Features of the head assembly (shown in Figure 1) and their functions are:

Wire Inserter—forces unstripped wire into the two slotted beams of the contact.

Wire Insertion Rod and Adjuster—acts as a piston for, and regulates travel of, the wire inserter.

Carriage—slides right and left in head assembly and automatically advances the connector after each termination.

Drag—prevents connector from moving out of position after it has been advanced.

Connector Slot—opening into which connector is secured in head assembly.

Adjustable Stop—controls the size of the connector slot, permitting different size connectors to be secured in head assembly.

Wire Guide—open channel into which unstripped wire is inserted and bottomed for terminating.

Feed Pawl—when pushed forward, allows carriage to be moved either right or left, depending on where connector is to be located in head assembly.

The wire is terminated in the connector contact using the insulation displacement technique (a terminating

technique which inserts unstripped wire into a slotted contact beam to form a reliable electrical connection between the wire and the contact). Contact termination is complete when the tool is actuated.

3. SETUP

The setup procedure consists of determining the size of the connector slot, securing the connector in that slot, and positioning the connector for termination. Proceed as follows:

1. To determine the size of slot required for the connector to be terminated, push the feed pawl forward and slide the carriage to the left as far as it will go. Then loosen the socket head cap screw located at bottom side of the adjustable stop, (shown in Figure 2), allowing the stop to be moved right or left.

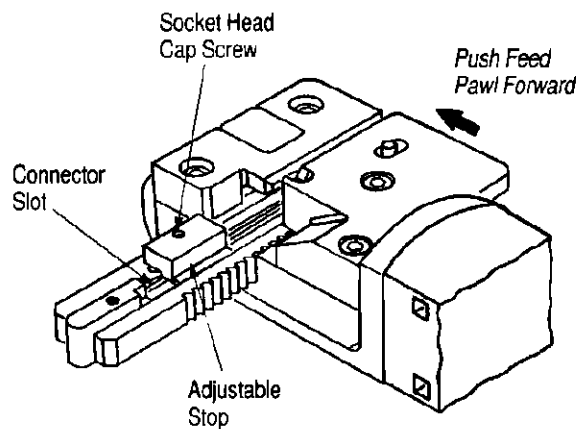

Figure 2

2. Orient the connector with the head assembly as shown in Figure 3: the open part of the insulation displacement slot is up and facing the back of the tool. Making sure that the connector slot is large enough to accept the connector, fit the connector in slot. Then move the adjustable stop flush against the connector and tighten the socket head cap screw, securing connector to head assembly.

3. Push the feed pawl forward and slide carriage (with connector) to the right as far as it will go. Then release feed pawl. The connector is now in position to begin termination.

4. TEST TERMINATION AND INSPECTION

At least one termination should be performed and inspected before starting production terminating. The steps which follow are recommended to perform the test termination and inspection.

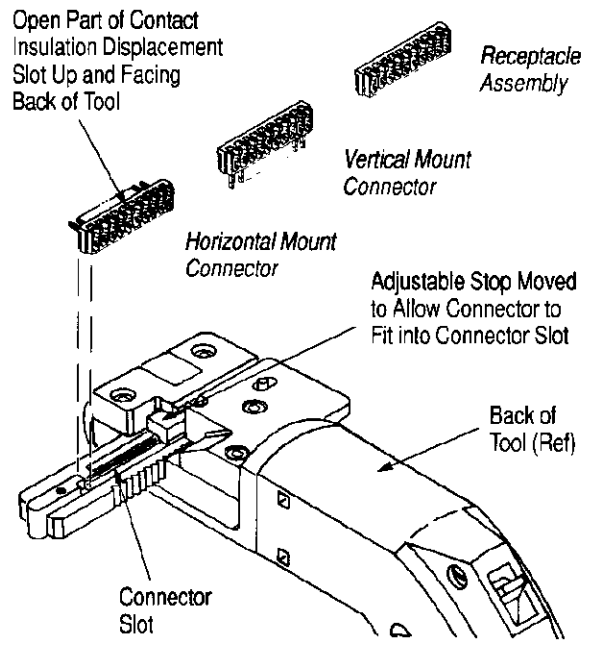

Figure 3

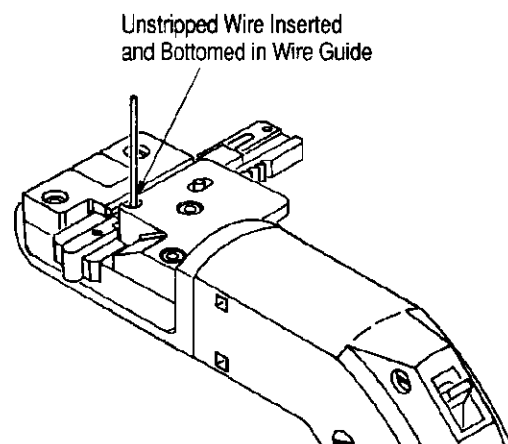

Figure 4

1. Perform the setup procedure as described in Section 3. Note that at the end of this procedure the connector is in position to begin the termination process.

2. Without inserting the wire into the wire guide, perform one cycle. The connector will be indexed in position for the first termination.

3. Insert an *unstripped* wire into the wire guide until the wire bottoms, making sure wire is centered in the slot. See Figure 4.

4. Perform one termination cycle: the inserter will bottom, forcing the wire between the contact slots, and will then retract. The connector will advance to the next contact position.

5. Release the feed pawl by pushing it forward then move the carriage to left and remove the connector from head assembly.

6. Inspect termination in accordance with AMP Application Specification 114-5103. If wire insertion depth is incorrect or if the carriage is not feeding properly, refer to Section 5.

5. ADJUSTMENTS

5.1. Wire Insertion Depth (Figure 5)

A. For Pistol Grip Manual Handle Assembly

If the wire is too deep in the contact insulation displacement slot, remove the head from the tool and turn the adjuster $\frac{1}{6}$ -revolution *clockwise*. This will reduce the wire insertion depth by approximately 0.20 mm [.008 in.]. Install the head onto the tool; then terminate and inspect a sample connector.

If the wire is not deep enough in the contact insulation displacement slot, remove the head from the tool and turn the adjuster $\frac{1}{6}$ -revolution *counterclockwise*. This will increase the wire insertion depth by approximately 0.20 mm [.008 in.]. Install the head onto the tool; then terminate and inspect a sample connector.

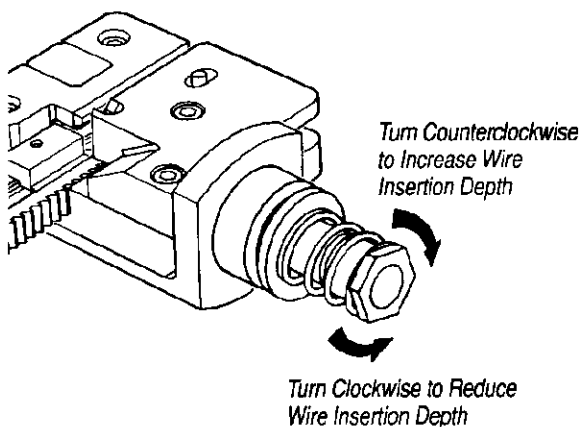

Figure 5

B. For Pneumatic Assembly

DANGER

To avoid personal injury, ALWAYS disconnect air supply from pneumatic power bench when removing head from tool.

1. Increase the air pressure for the pneumatic bench mount in increments of 69 kPa [10 psi] until proper wire insertion depth is obtained.

CAUTION Do NOT increase the air pressure beyond 483 kPa [70 psi]; otherwise, excessive wear and strain to the tool and head could result.

2. If the proper wire insertion depth is not obtained, set the air pressure to 276 kPa [40 psi] and follow the procedure in Paragraph 5.1, A.

5.2. Carriage Feed

The carriage feed adjustment setscrew, shown in Figure 6, controls the location of the carriage. If the screw is positioned in too far, the feed pawl will not engage in the carriage and the carriage will not advance. If the screw is out too far, the carriage will back up until the feed pawl engages, and thus, will incorrectly position the contact to be terminated. Adjust the carriage by turning the adjustment screw either in or out until the contact aligns with the wire inserter.

Once the carriage feed is adjusted correctly, the following should be observed:

- wire inserter is aligned with the connector contact
- no movement of the connector housing occurs as the tool is actuated

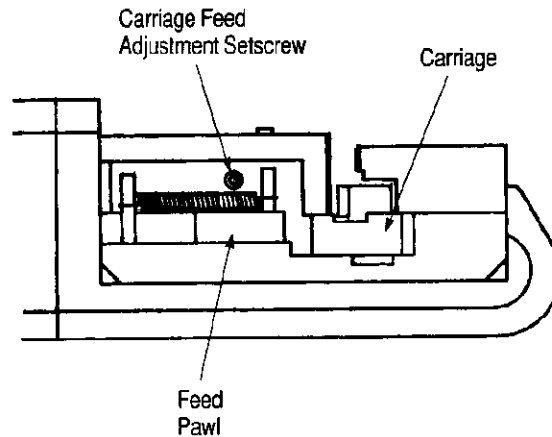

Figure 6

6. TERMINATION PROCEDURE

1. Select the applicable connector and wire to be terminated.

2. Perform the setup procedure as described in Section 3. Note that at the end of this procedure the connector is in position to begin the termination process.

3. Without inserting the wire into the wire guide, perform one cycle. The connector will be indexed in position for the first termination.
4. Insert an *unstripped* wire into the wire guide until the wire bottoms, making sure wire is centered in the slot.
5. Perform one termination cycle: the inserter will bottom, forcing the wire between the contact slots, and will then retract. The connector will advance to the next contact position.
6. Continue to insert unstripped wire and cycle the tool until all contacts of the connector are terminated.
7. Remove the connector from the left side of the carriage.
8. Repeat these steps until all connectors are terminated.

7. MAINTENANCE AND INSPECTION

7.1. Daily Maintenance

It is recommended that each operator of the head assembly be made aware of—and responsible for—the following steps of daily maintenance:

1. Remove dust, moisture, and other contaminants with a clean brush or a soft, lint-free cloth. Do NOT use objects that could damage the head assembly.
2. Make sure all components are in place and are properly secured.
3. Actuate tool to ensure that mechanisms inside the head assembly move smoothly.

7.2. Periodic Inspection

Regular inspections should be performed by quality control personnel. A record of scheduled inspections should remain with the head assembly or be supplied to supervisory personnel responsible for the head assembly. Though recommendations call for at least one inspection a month, the inspection frequency should be based on the amount of use, ambient working conditions, operator training and

skill, and established company standards. These inspections should include a visual inspection and should be performed in the sequence listed.

1. Remove any accumulated film with a suitable commercial degreaser that will not affect paint or plastic material.
2. Make sure all components are in place and are properly secured.
3. Make a few test terminations and inspect the terminations in accordance with 114-5103.
4. Check for chipped, cracked, worn, or broken areas. If damage is evident, repair is necessary. See Section 8.

8. REPLACEMENT AND REPAIR

Customer-replaceable parts are provided in Figure 7. A complete inventory should be stocked and controlled to prevent lost time when replacement of parts is necessary. Order replacement parts through your AMP representative, or call 1-800-526-5142, or send a facsimile of your purchase order to 717-986-7605 or write to:

CUSTOMER SERVICE (038-035)
AMP INCORPORATED
PO BOX 3608
HARRISBURG PA 17105-3608

Parts other than those specified in Figure 7 must be replaced by AMP to ensure the quality and reliability of the head assembly. When repair is necessary, return the head with a written description of the problem to:

CUSTOMER REPAIR (01-12)
AMP INCORPORATED
1523 NORTH 4TH STREET
HARRISBURG PA 17102-1604

9. REVISION SUMMARY

Revisions to this instruction sheet include:

Per EC 0990-1245-96:

- Changed part number of Items 1, 2, and 20 in Figure 7

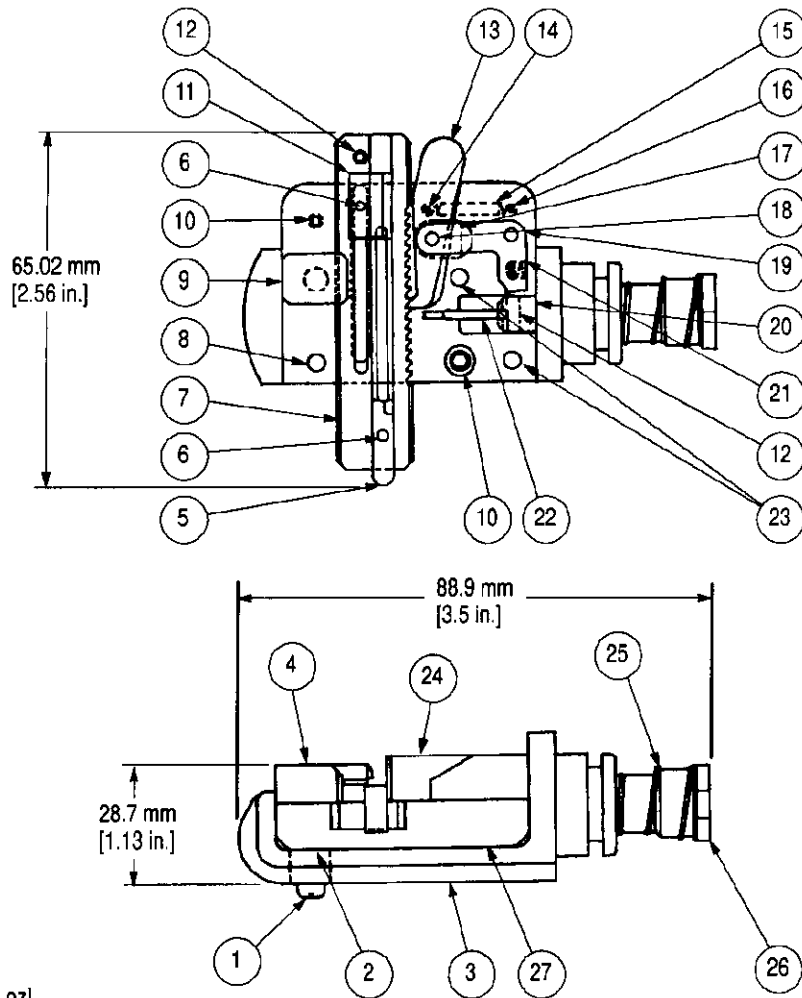

Weight: 142 g [5 oz]

REPLACEMENT PARTS

ITEM	PART NUMBER	DESCRIPTION	QTY PER ASSEMBLY
1	1-21989-2	SCREW, Socket Head Shoulder	1
2	2-22281-2	SPRING, Compression	1
3	314058-1	HEAD, Finished	1
4	314061-1	GUIDE, Housing	1
5	314066-1	STOP, Fixed	1
6	21000-9	SCREW, Socket Head Cap, 2-56x.19 L	2
7	314062-1	CARRIAGE	1
8	1-21000-6	SCREW, Socket Head Cap, 4-40x.62 L	1
9	314065-1	DRAG	1
10	1-21000-4	SCREW, Socket Head Cap, 4-40x.38 L	2
11	314067-1	STOP, Adjustable	1

Figure 7 (Continued)

12	3-21028-2	PIN, Slotted Spring	2
13	314063-1	PAWL, Feed	1
14	21028-3	PIN, Slotted Spring	1
15	4-22487-0	SPRING, Extension	1
16	21028-6	PIN, Slotted Spring	1
17	2-21008-1	SCREW, Set, 4-40x.25 L	1
18	1-21919-2	PIN, Dowel	2
19	314064-1	ARM, Feed	1
20	1-22278-2	SPRING, Compression	1
21	312148-6	ROD, Inserter	1
22	314068-1	INSERTER, Wire	1
23	1-21000-7	SCREW, Socket Head Cap, 4-40x.75 L	2
24	314060-1	GUIDE, Wire	1
25	5-22488-6	SPRING, Compression	1
26	312149-1	ADJUSTER, Rod Inserter	1
27	314059-1	BASE	1

Figure 7 (End)