

PROPER USE GUIDELINES

Cumulative Trauma Disorders can result from the prolonged use of manually powered hand tools. AMP hand tools are intended for occasional use and low volume applications. AMP offers a wide selection of powered application equipment for extended-use, production operations.

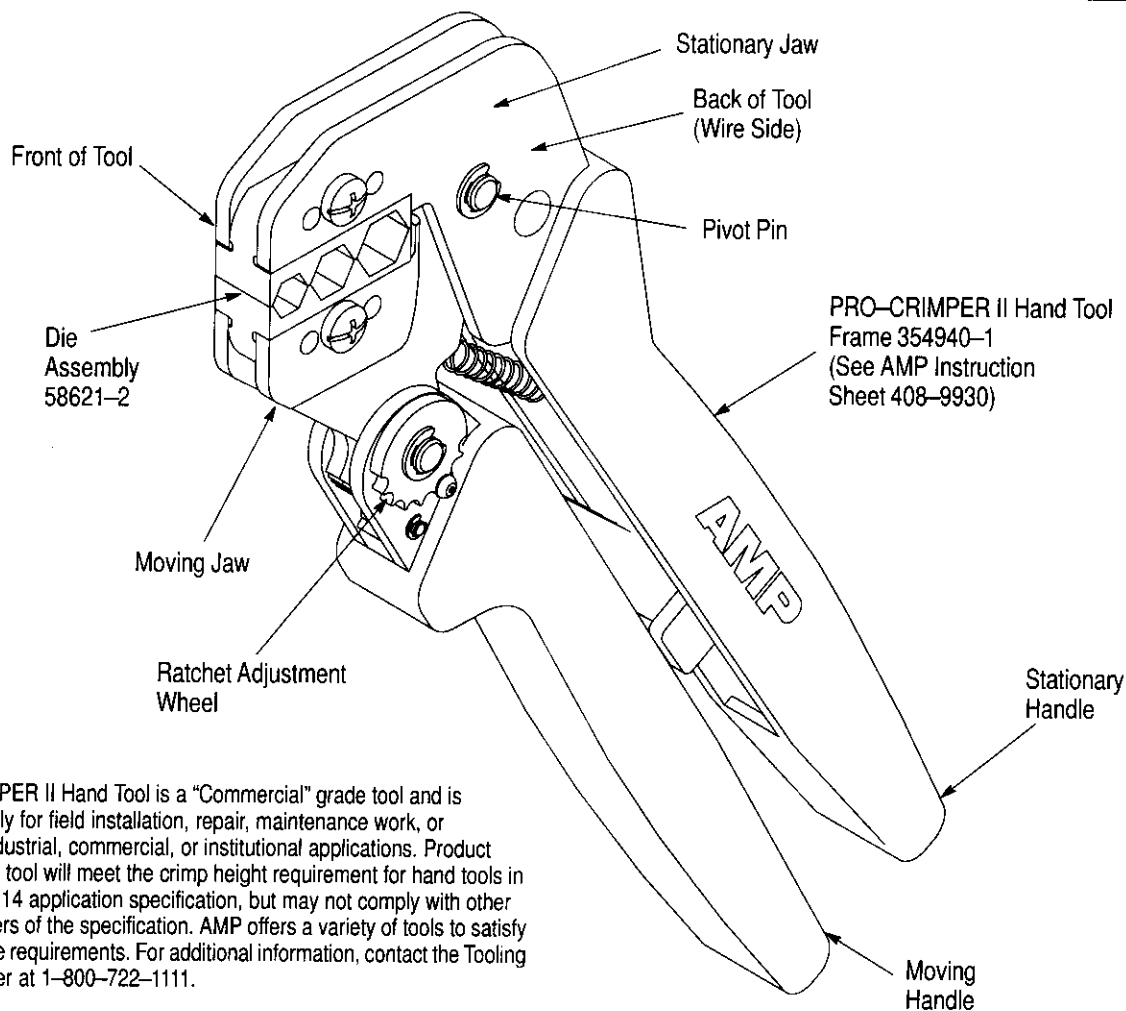

The PRO-CRIMPER II Hand Tool is a "Commercial" grade tool and is designed primarily for field installation, repair, maintenance work, or prototyping in industrial, commercial, or institutional applications. Product crimped with this tool will meet the crimp height requirement for hand tools in the appropriate 114 application specification, but may not comply with other feature parameters of the specification. AMP offers a variety of tools to satisfy your performance requirements. For additional information, contact the Tooling Assistance Center at 1-800-722-1111.

Figure 1

1. INTRODUCTION

AMP* PRO-CRIMPER II Hand Tool Assembly 58621-1 consists of Die Assembly 58621-2 and AMP PRO-CRIMPER II Hand Tool Frame 354940-1. The tool is designed to crimp AMP Coaxial Series F connector onto Cable Series 59, Series 6, and Series 7 Quad. For instructions concerning the operation of the hand tool, refer to AMP Instruction Sheet 408-9930.

AMP Catalog 124359 provides a selection of Series F connectors. For connectors not referenced in the catalog, contact AMP Product Engineering for connector recommendations.

NOTE

Dimensions on this sheet are in millimeters [with inch equivalents provided in brackets]. Figures and illustrations are for identification only and are not drawn to scale.

2. DESCRIPTION (Figure 1)

The tool features a tool frame with a stationary jaw and handle, a moving jaw, a moving handle, and an adjustable ratchet that ensures full connector crimping. The tool frame holds the die assembly.

The die assembly features identical upper and lower crimping dies and three ferrule crimp sections. The ferrule crimp sections are identified by their hex size. Each die is held in the hand tool by a single screw.

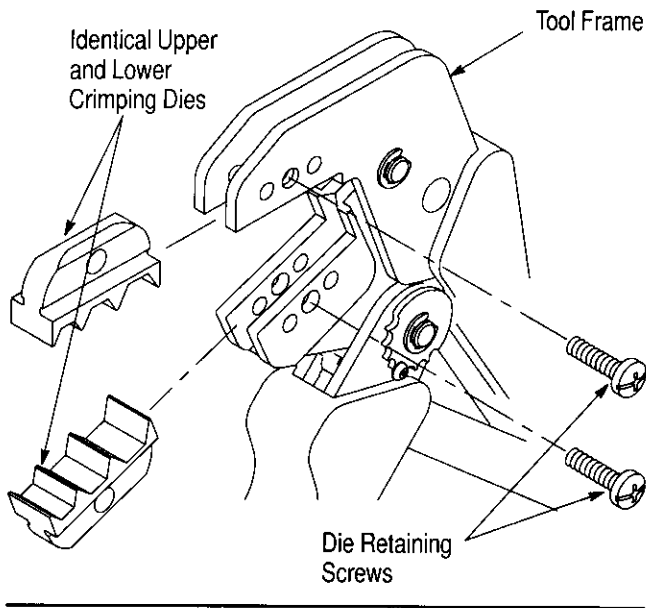

Figure 2

3. INSTALLATION AND REMOVAL OF DIE ASSEMBLY

(Figure 2)

1. Open the tool handles and remove the two die retaining screws from the tool jaws.
2. Slide the die assembly into the partially opened tool jaws.
3. Insert the die retaining screws and tighten the screws just enough to hold the dies in place. Do *not* tighten the screws completely at this time.
4. Carefully close the tool handles, making sure the dies align properly. Continue closing the tool handles until the ratchet in the tool frame has

engaged sufficiently to hold the die in place, then tighten both die retaining screws.

5. To disassemble, close the tool handles until the ratchet releases, remove the two die retaining screws, and slide the dies out of the tool jaws.

4. CRIMPING PROCEDURE

4.1. Connector Preparation

1. Strip cable according to the dimensions in the appropriate connector instruction sheet.
2. Assemble connector to cable per procedure stated on instruction sheet.

4.2. Connector Crimp

1. See appropriate connector instruction sheet.
2. Place connector in bottom half of die assembly so that the shoulder on the connector is approximately 3.18 [.125] from end of die. See Figure 3.
3. Holding the assembly in place, close the tool handles until the ratchet releases.
4. Remove the crimped assembly from the crimping die.

5. INSPECTION

5.1. Visual Inspection

Inspection of the crimping dies should be made on a regular basis to ensure that they have not become worn or damaged. Inspect the crimp sections for flattened, chipped, worn, or broken areas. If damage or abnormal wear is evident, the dies must be replaced. Refer to Section 7, REPLACEMENT.

Connector Placement in Dies

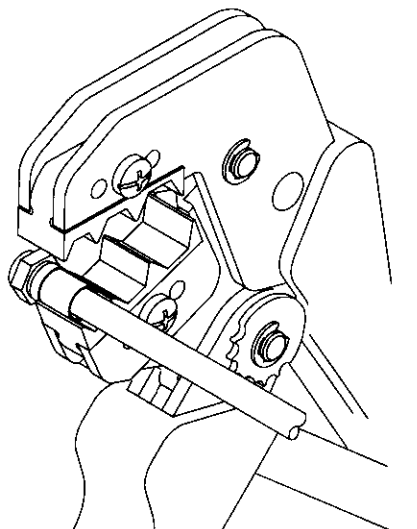

Crimping Ferrule

Connector Approximately 3.18 [.125] From End of Die

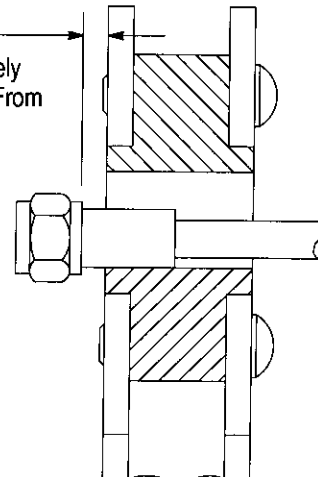

Figure 3

5.2. Measuring Die Opening

The die assembly will perform correctly as long as:

- (1) the product specified is correct for the application,
- (2) the specific die assembly is used, (3) the die assembly has been measured to ensure that the openings are correct, and (4) the tool has been adjusted correctly.

Figure 4 provides information on die opening sizes.

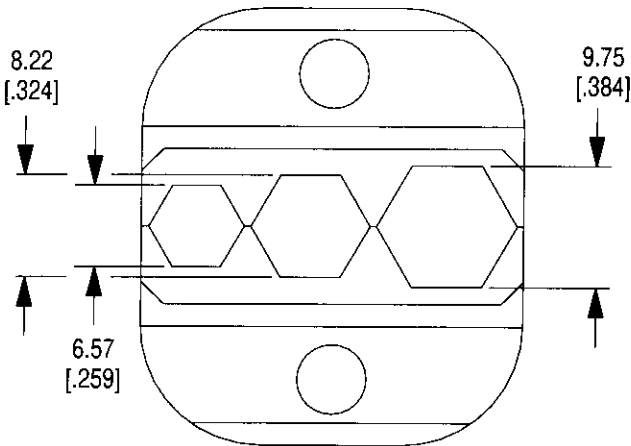

Figure 4

5.3. Ratchet Adjustment (Figure 5)

The ratchet mechanism features an adjustment wheel with eight settings. The adjustment wheel controls the amount of handle pressure exerted on the tool jaws and crimping dies during crimping. If the crimp is not acceptable, adjust the ratchet as follows:

1. Sufficiently loosen the screw at the ratchet adjustment wheel so that the wheel can be rotated above the post that engages the teeth in the wheel.
2. If the crimp is too loose, turn the wheel to a higher notch (for example, if the wheel is set at notch no. 5, move the wheel to notch no. 6). If the crimp is too tight, move the wheel to a lower notch.
3. Tighten the screw at the ratchet adjustment wheel.

If the crimp cannot be made to conform to the dimensions provided in the appropriate product application specification, the tool and/or dies are defective and must be replaced.

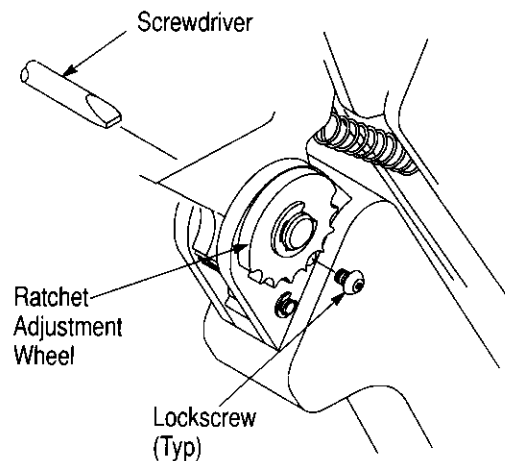

Figure 5

NOTE

Other dies of the PRO-CRIMPER series may be used in this tool; however, the ratchet adjustment wheel may require adjustment to achieve acceptable crimp height.

6. MAINTENANCE

Ensure that the tool and dies are clean by wiping them with a clean, soft cloth. Remove any debris with a clean, soft brush. Do not use objects that could damage the tool. When not in use, keep handles closed to prevent objects from becoming lodged in the dies, and store in a clean, dry area.

7. REPLACEMENT

Customer-replaceable parts are shown in Figure 1. Available separately, Repair Kit 679221-1 includes a replacement nut and a variety of pins, rings, screws, and springs. If the dies are damaged or worn excessively, they must be replaced. Order the repair kit and replaceable parts through your AMP representative, or call 1-800-526-5142, or send a facsimile of your purchase order to 1-717-986-7605, or write to:

CUSTOMER SERVICE (38-35)
AMP INCORPORATED
P.O. BOX 3608
HARRISBURG, PA 17105-3608