

EVALUATION KIT
AVAILABLE

MAXIM

Low-Cost, High-Reliability, 0.5V to 3.3V ORing MOSFET Controllers

General Description

Critical loads often employ parallel-connected power supplies with redundancy to enhance system reliability. The MAX8555/MAX8555A are highly integrated, inexpensive MOSFET controllers that provide isolation and redundant power capability in high-reliability systems. The MAX8555/MAX8555A are used in 0.5V to 3.3V systems, and have an internal charge pump to drive the gates of the N-channel pass elements to ($V_{CS+} + 5V$).

During startup, the MAX8555/MAX8555A monitor the voltage drop across the external MOSFETs. Once V_{CS+} approaches or exceeds the bus voltage (V_{CS-}), the MOSFETs are turned on. The MAX8555/MAX8555A feature a dual-purpose TIMER input. A single external resistor from TIMER to ground sets the turn-on speed of the external MOSFETs. Optionally, the TIMER input can be used as a logic enable input. Once the external MOSFET is turned on, these controllers monitor the load, protecting the bus against overvoltage, undervoltage, and reverse-current fault conditions. The MAX8555 is available with a 40mV reverse-current threshold, while the MAX8555A is available with a 20mV reverse-current threshold.

Overvoltage and undervoltage fault thresholds are adjustable and can be disabled. The current-limit trip points are set by the external MOSFETs' $R_{DS(ON)}$, reducing component count. An open-drain, logic-low fault output indicates if an overvoltage, undervoltage, or reverse-current fault occurs. The MAX8555 and the MAX8555A can shut down in response to a reverse-current fault condition as quickly as 200ns.

Both devices come in space-saving 10-pin μ MAX or TDFN packages and are specified over the extended -40°C to +85°C temperature range.

Applications

- Point-of-Load Supplies
- Power-Supply Modules
- Servers
- Telecom Power Supplies
- Rectifiers
- Redundant Power Supplies in High-Availability Systems

Typical Operating Circuit appears at end of data sheet.

Features

- ◆ Simple, Integrated, and Inexpensive MOSFET Controllers
- ◆ ORing FET Drive for 0.5V to 3.3V
- ◆ Eliminate ORing Diode Power Dissipation
- ◆ Provide N+1 Redundant Supply Capability for Highly Reliable Systems
- ◆ Isolate Failed Short-Circuit Supply from Output BUS
- ◆ Respond to Reverse Short-Circuit Current in 200ns
- ◆ Adjustable Blank Time
- ◆ Programmable Soft-Start
- ◆ Logic Enable Input
- ◆ Adjustable Overvoltage and Undervoltage Trip Points
- ◆ Fault-Indicator Output
- ◆ Space-Saving Packages

Ordering Information

| PART | TEMP RANGE | PIN-PACKAGE | TOP MARK |
|-------------|---------------|-----------------------|----------|
| MAX8555ETB | -40°C to 85°C | 10 TDFN 3mm x 3mm* | ACC |
| MAX8555EUB | -40°C to 85°C | 10 μ MAX | 8555EUB |
| MAX8555AETB | -40°C to 85°C | 10 TDFN 3mm x 3mm* | ADD |
| MAX8555AEUB | -40°C to 85°C | 10 μ MAX | 8555AEUB |

*Exposed paddle

Pin Configurations

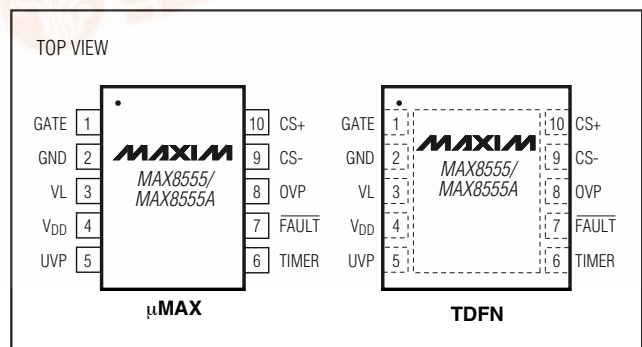

MAX8555/MAX8555A

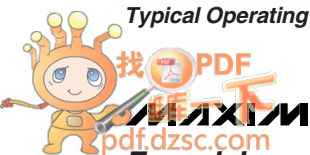

Low-Cost, High-Reliability, 0.5V to 3.3V ORing MOSFET Controllers

ABSOLUTE MAXIMUM RATINGS

| | |
|---|------------------------------------|
| GATE to GND | -0.3V to +12V |
| FAULT, VL to GND | -0.3V to +6V |
| OVP, UVP, TIMER, CS+, CS- to GND | -0.3V to +(V _{VL} + 0.3V) |
| V _{DD} to GND | (V _{VL} - 0.3V) to +18V |
| Continuous Power Dissipation (T _A = +70°C) | |
| 10-Pin μMAX (derate 5.6mW/°C above +70°C) | 444mW |
| 10-Pin TDFN (derate 24.4mW/°C above +70°C) | 1951mW |

| | |
|---|-----------------|
| Operating Temperature Range | -40°C to +85°C |
| Junction Temperature | +150°C |
| Storage Temperature Range | -65°C to +150°C |
| Lead Temperature (soldering, 10s) | +300°C |

Stresses beyond those listed under "Absolute Maximum Ratings" may cause permanent damage to the device. These are stress ratings only, and functional operation of the device at these or any other conditions beyond those indicated in the operational sections of the specifications is not implied. Exposure to absolute maximum rating conditions for extended periods may affect device reliability.

ELECTRICAL CHARACTERISTICS

(V_{DD} = 12V, V_{CS-} = 1.4V, V_{CS+} = 1.5V, R_{TIMER} = 25kΩ, V_{UVP} = 1V, V_{OVP} = 0.25V, R_{FAULT} = 50kΩ, C_{VDD} = C_{GATE} = C_{VL} = 0.01μF, T_A = 0°C to +85°C, unless otherwise noted.)

| PARAMETER | CONDITIONS | MIN | TYP | MAX | UNITS | |
|--|---|--|------|------|-----------------------|-----|
| V_{DD} SUPPLY | | | | | | |
| V _{DD} Input Voltage | V _{TIMER} = 2.5V | VL unconnected | | 8.00 | 13.25 | V |
| | | VL = V _{DD} | | 3.0 | 5.5 | |
| V _{DD} Supply Current | VL unconnected, V _{TIMER} = 2.5V, V _{DD} = 13.25V | | | 2.0 | 3.3 | mA |
| | V _{DD} = V _{VL} = 5V, V _{TIMER} = 2.5V | | | 0.04 | 0.2 | |
| V _{DD} Shutdown Current | V _{TIMER} = 0V, V _{DD} = 13.25V | | | | 3.0 | mA |
| V _{DD} Overvoltage Internal Threshold | Rising threshold | | 14.0 | 14.4 | 15.0 | V |
| | Falling threshold | | 13.3 | 13.8 | 14.5 | |
| VL SUPPLY | | | | | | |
| VL Input Voltage | V _{DD} = V _{VL} | | 3.0 | | 5.5 | V |
| VL Supply Current | V _{DD} = V _{VL} = 5V, V _{TIMER} = 2.5V | | | 1.8 | 3.0 | mA |
| VL Current in Shutdown Mode | TIMER = GND, V _{DD} = V _{VL} = 5V | | | 1.6 | 3.0 | mA |
| VL Output Voltage | V _{DD} = 8V to 13.25V, I _{VL} = 0A | | 3.80 | 4.1 | 4.45 | V |
| VL Undervoltage Lockout | VL = V _{DD} , rising threshold | | 2.78 | 2.82 | 2.90 | V |
| | VL = V _{DD} , falling threshold | | 2.68 | 2.75 | 2.82 | |
| CS INPUTS | | | | | | |
| CS+, CS- Input Current | V _{TIMER} = 2.5V, V _{CS} = 3.0V | | | 5.2 | | μA |
| Offset Input Current (CS+, CS-) | V _{CS} = 3.0V, Figure 4 | | -250 | | +250 | nA |
| CS+/CS- Input Range | (Note 1) | | 0.5 | | V _{VL} - 0.5 | V |
| CS Isolation | V _{CS+} = +3V, V _{CS-} = 0V, I _{CS-} | | | -0.5 | | μA |
| | V _{CS-} = +3V, V _{CS+} = 0V, I _{CS+} | | | -0.5 | | |
| CHARGE-PUMP VOLTAGE | | | | | | |
| GATE Voltage, V _{GATE} | Measured from GATE to CS+ | V _{DD} = 8V to 13.25V | 5.0 | 5.25 | 5.5 | V |
| | | V _{DD} = V _{VL} = 5V | | | | |
| Charge-Pump Switching Frequency | R _{TIMER} = 20kΩ | | | 187 | | kHz |
| | R _{TIMER} = 125kΩ | | | 450 | | |
| | R _{TIMER} = open | | | 500 | | |
| | V _{TIMER} = 1.5V | | | 550 | | |

Low-Cost, High-Reliability, 0.5V to 3.3V ORing MOSFET Controllers

MAX8555/MAX8555A

ELECTRICAL CHARACTERISTICS (continued)

(V_{DD} = 12V, V_{CS-} = 1.4V, V_{CS+} = 1.5V, R_{TIMER} = 25kΩ, V_{UVP} = 1V, V_{OVP} = 0.25V, R_{FAULT} = 50kΩ, C_{VDD} = C_{GATE} = C_{VL} = 0.01μF, T_A = 0°C to +85°C, unless otherwise noted.)

| PARAMETER | CONDITIONS | MIN | TYP | MAX | UNITS | |
|--|--|----------------------------|------|-----------------|-------|----|
| TIMER | | | | | | |
| TIMER Voltage | | 1.22 | 1.25 | 1.28 | V | |
| TIMER Maximum Source Current | V _{TIMER} = 1.0V | 85 | 100 | 115 | μA | |
| TIMER High Input Current | V _{TIMER} = 1.5V | | 10 | 15 | μA | |
| TIMER Maximum Frequency Select Voltage Input Range | (Note 1) | 1.5 | | V _{VL} | V | |
| TIMER Logic High, V _{IH} | Charge pump enabled | 1.0 | | | V | |
| TIMER Logic Low, V _{IL} | Charge pump disabled | | | 0.5 | V | |
| FAULT | | | | | | |
| Fault Output Low Voltage | I _{FAULT} = 10mA | | | 0.2 | V | |
| Fault Sink Current | V _{FAULT} = 0.4V | 15 | | | mA | |
| Fault Leakage Current | V _{FAULT} = 5.5V, T _A = +25°C | | | 1 | μA | |
| GATE | | | | | | |
| Gate-On Threshold | Measured from CS- to CS+ | MAX8555 | 80 | 100 | 120 | mV |
| | | MAX8555A | 35 | 50 | 65 | |
| Gate-Drive Current | V _{GATE} = V _{CS+} = 2.5V | R _{TIMER} = open | 17 | 25 | 33 | μA |
| | | R _{TIMER} = 25kΩ | 8 | 12 | 16 | |
| | V _{GATE} = V _{CS+} = 2.5V, V _{DD} = V _{VL} = 3V | R _{TIMER} = open | | 15 | | |
| | | R _{TIMER} = 25kΩ | | 7.5 | | |
| | V _{GATE} = V _{CS+} = 2.5V, V _{DD} = V _{VL} = 5V | R _{TIMER} = open | | 30 | | |
| | | R _{TIMER} = 25kΩ | | 15 | | |
| Gate Shutdown Delay | (Note 2) | V _{TIMER} falling | | 100 | 200 | ns |
| | | I _{REV} fault | | 60 | 150 | |
| Gate Discharge Current | V _{GATE} = V _{CS+} = +5V | | 1000 | | mA | |
| GATE Fall Time | Gate voltage fall from $\overline{\text{FAULT}}$ to V _{GATE} = V _{CS+} , R ₁ = 2Ω, Figure 3 or Figure 4 | | 0.2 | | μs | |
| CURRENT SENSE | | | | | | |
| Reverse-Current Threshold | Measured from CS- to CS+ | MAX8555 | 34 | 40 | 46 | mV |
| | | MAX8555A | 16 | 20 | 24 | |
| Startup I _{REV} Blank Time | TIMER = unconnected | | 4.1 | | ms | |
| Forward-Current Threshold | Measured from CS+ to CS- | 6 | 10 | 14 | mV | |

Low-Cost, High-Reliability, 0.5V to 3.3V ORing MOSFET Controllers

ELECTRICAL CHARACTERISTICS (continued)

($V_{DD} = 12V$, $V_{CS-} = 1.4V$, $V_{CS+} = 1.5V$, $R_{TIMER} = 25k\Omega$, $V_{UVP} = 1V$, $V_{OVP} = 0.25V$, $R_{FAULT} = 50k\Omega$, $C_{VDD} = C_{GATE} = C_{VL} = 0.01\mu F$, $T_A = 0^{\circ}C$ to $+85^{\circ}C$, unless otherwise noted.)

| PARAMETER | CONDITIONS | MIN | TYP | MAX | UNITS |
|--------------------------------|----------------------|-------|-------|-------|---------|
| OVERVOLTAGE PROTECTION | | | | | |
| OVP Fault Threshold, V_{OVP} | OVP rising | 0.49 | 0.5 | 0.51 | V |
| | OVP falling | | 0.4 | | |
| OVP Bias Current | $T_A = +25^{\circ}C$ | | | 0.1 | μA |
| | $T_A = +85^{\circ}C$ | | 0.021 | | |
| UNDERVOLTAGE PROTECTION | | | | | |
| UVP Fault Threshold, V_{UVP} | UVP rising | 0.488 | 0.5 | 0.512 | V |
| | UVP falling | | 0.4 | | |
| UVP Bias Current | $T_A = +25^{\circ}C$ | | | 0.1 | μA |
| | $T_A = +85^{\circ}C$ | | 0.003 | | |

ELECTRICAL CHARACTERISTICS

($V_{DD} = 12V$, $V_{CS-} = 1.4V$, $V_{CS+} = 1.5V$, $R_{TIMER} = 25k\Omega$, $V_{UVP} = 1V$, $V_{OVP} = 0.25V$, $R_{FAULT} = 50k\Omega$, $C_{VDD} = C_{GATE} = C_{VL} = 0.01\mu F$, $T_A = -40^{\circ}C$ to $+85^{\circ}C$, unless otherwise noted.) (Note 3)

| PARAMETER | CONDITIONS | MIN | TYP | MAX | UNITS | |
|---|--|---------------------------|------|-------|----------------|----|
| V_{DD} SUPPLY | | | | | | |
| V_{DD} Input Voltage | $V_{TIMER} = 2.5V$ | VL unconnected | | 13.25 | V | |
| | | VL = V_{DD} | 8.00 | 5.5 | | |
| V_{DD} Supply Current | VL unconnected, $V_{TIMER} = 2.5V$, $V_{DD} = 13.25V$ | | | 3.3 | mA | |
| | $V_{DD} = V_{VL} = 5V$, $V_{TIMER} = 2.5V$ | | | 0.2 | | |
| V_{DD} Shutdown Current | $V_{TIMER} = 0V$, $V_{DD} = 13.25V$ | | | 3.0 | mA | |
| V_{DD} Overvoltage Internal Threshold | Rising threshold | 14.0 | | 15.0 | V | |
| | Falling threshold | 13.3 | | 14.5 | | |
| VL SUPPLY | | | | | | |
| VL Input Voltage | $V_{DD} = V_{VL}$ | | | 3.0 | 5.5 | V |
| VL Supply Current | $V_{DD} = V_{VL} = 5V$, $V_{TIMER} = 2.5V$ | | | | 3.0 | mA |
| VL Current in Shutdown Mode | TIMER = GND, $V_{DD} = V_{VL} = 5V$ | | | | 3.0 | mA |
| VL Output Voltage | $V_{DD} = 8V$ to $13.25V$, $I_{VL} = 0A$ | | | 3.80 | 4.45 | V |
| VL Undervoltage Lockout | VL = V_{DD} , rising threshold | | | 2.78 | 2.90 | V |
| | VL = V_{DD} , falling threshold | | | 2.68 | 2.82 | |
| CS INPUTS | | | | | | |
| Offset Input Current (CS+, CS-) | $V_{CS} = 3.0V$, Figure 4 | | | -250 | +250 | nA |
| CS+/CS- Input Range | (Note 1) | | | 0.5 | $V_{VL} - 0.5$ | V |
| CHARGE-PUMP VOLTAGE | | | | | | |
| GATE Voltage, V_{GATE} | Measured from GATE to CS+ | $V_{DD} = 8V$ to $13.25V$ | | 5.0 | 5.5 | V |
| | | $V_{DD} = V_{VL} = 5V$ | | | | |

Low-Cost, High-Reliability, 0.5V to 3.3V ORing MOSFET Controllers

MAX8555/MAX8555A

ELECTRICAL CHARACTERISTICS (continued)

(V_{DD} = 12V, V_{CS-} = 1.4V, V_{CS+} = 1.5V, R_{TIMER} = 25kΩ, V_{UVP} = 1V, V_{OVP} = 0.25V, R_{FAULT} = 50kΩ, C_{VDD} = C_{GATE} = C_{VL} = 0.01μF, T_A = -40°C to +85°C, unless otherwise noted.) (Note 3)

| PARAMETER | CONDITIONS | MIN | TYP | MAX | UNITS |
|--|---|----------------------------|-----|-----------------|-------|
| TIMER | | | | | |
| TIMER Voltage | | 1.22 | | 1.28 | V |
| TIMER Maximum Source Current | V _{TIMER} = 1.0V | 85 | | 115 | μA |
| TIMER High Input Current | V _{TIMER} = 1.5V | | | 15 | μA |
| TIMER Maximum Frequency Select Voltage Input Range | (Note 1) | 1.5 | | V _{VL} | V |
| TIMER Logic High, V _{IH} | Charge pump enabled | 1.1 | | | V |
| TIMER Logic Low, V _{IL} | Charge pump disabled | | | 0.5 | V |
| FAULT | | | | | |
| Fault Output Low Voltage | I _{FAULT} = 10mA | | | 0.2 | V |
| Fault Sink Current | V _{FAULT} = 0.4V | 15 | | | mA |
| GATE | | | | | |
| Gate-On Threshold | Measured from CS- to CS+ | MAX8555 | 80 | 120 | mV |
| | | MAX8555A | 35 | 65 | |
| Gate-Drive Current | V _{GATE} = V _{CS+} = 2.5V | R _{TIMER} = open | 17 | 33 | μA |
| | | R _{TIMER} = 25kΩ | 8 | 16 | |
| Gate Shutdown Delay | | V _{TIMER} falling | | 200 | ns |
| | | I _{REV} fault | | 150 | |
| CURRENT SENSE | | | | | |
| Reverse-Current Threshold | Measured from CS- to CS+ | MAX8555 | 34 | 46 | mV |
| | | MAX8555A | 16 | 24 | |
| Forward-Current Threshold | Measured from CS+ to CS- | 6 | | 14 | mV |
| OVERVOLTAGE PROTECTION | | | | | |
| OVP Fault Threshold, V _{OVP} | OVP rising | 0.49 | | 0.51 | V |
| UNDERVOLTAGE PROTECTION | | | | | |
| UVP Fault Threshold, V _{UVP} | UVP rising | 0.488 | | 0.512 | V |

Note 1: Guaranteed by design. Not production tested.

Note 2: Gate shutdown delay is measured from reverse-current fault to the start of gate-voltage falling or from TIMER to the start of gate-voltage falling.

Note 3: Specifications to -40°C are guaranteed by design and not production tested.

Low-Cost, High-Reliability, 0.5V to 3.3V ORing MOSFET Controllers

Typical Operating Characteristics

($V_{DD} = 12V$, $V_{CS+} = 1.5V$, $R_{TIMER} = 25k\Omega$, $V_{UVP} = 1V$, $V_{OVP} = 0.4V$, $R_{FAULT} = 50k\Omega$ to output bus, $C_{VDD} = C_{GATE} = C_{VL} = 0.01\mu F$, $T_A = +25^\circ C$, $R1 = 2\Omega$ in Figure 3, MAX8555A, unless otherwise noted.)

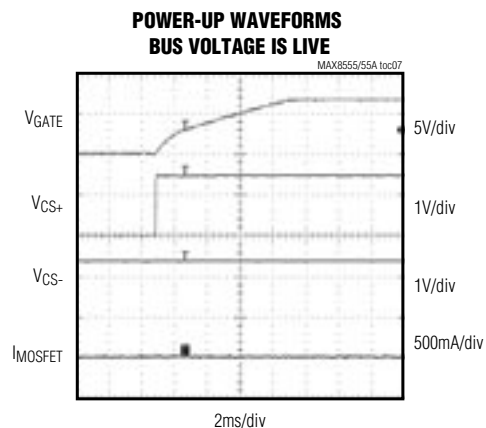
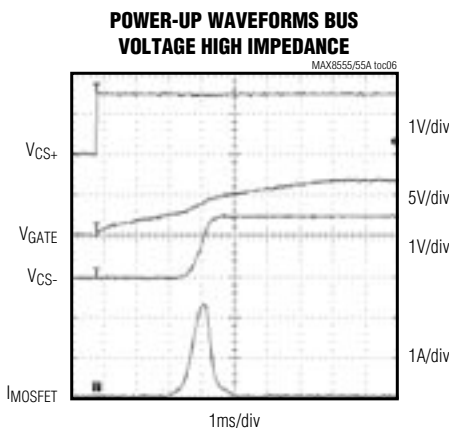
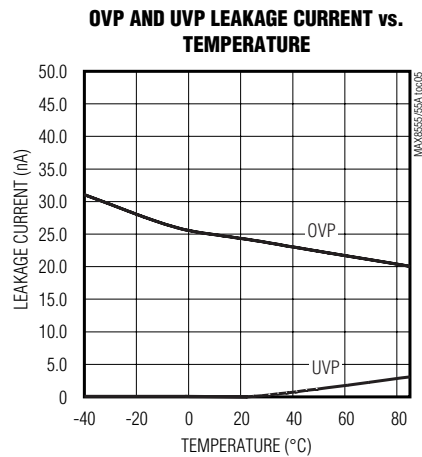
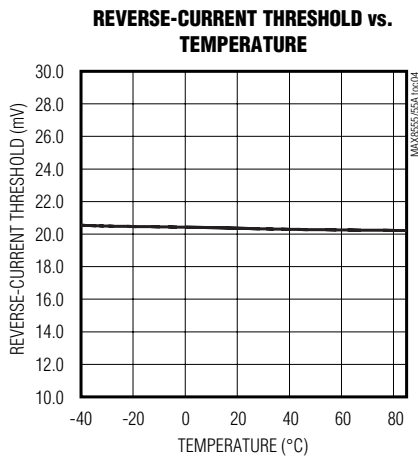
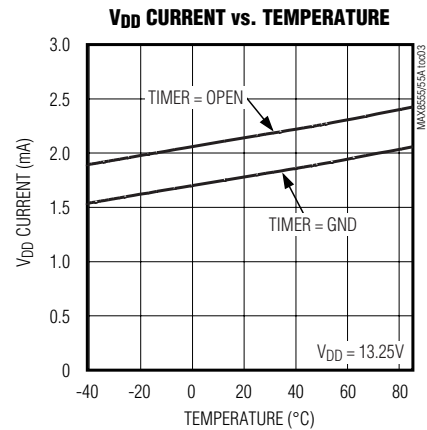
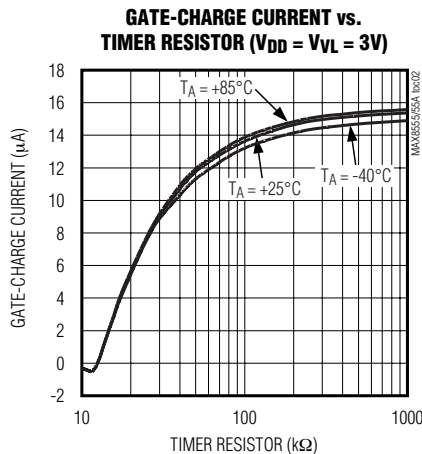
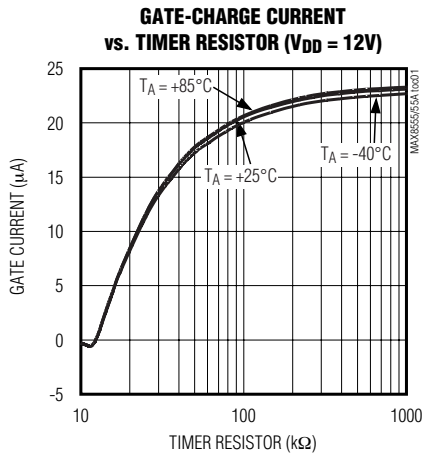

Low-Cost, High-Reliability, 0.5V to 3.3V ORing MOSFET Controllers

Typical Operating Characteristics (continued)

($V_{DD} = 12V$, $V_{CS+} = 1.5V$, $R_{TIMER} = 25k\Omega$, $V_{UVP} = 1V$, $V_{OVP} = 0.4V$, $R_{FAULT} = 50k\Omega$ to output bus, $C_{VDD} = C_{GATE} = C_{VL} = 0.01\mu F$, $T_A = +25^\circ C$, $R1 = 2\Omega$ in Figure 3, MAX8555A, unless otherwise noted.)

MAX8555/MAX8555A

POWER-UP AND DOWN WAVEFORMS USING TIMER

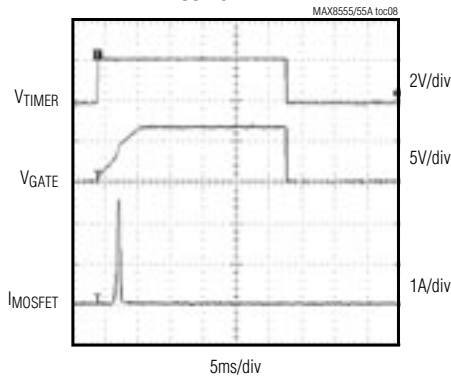

REVERSE-CURRENT SHUTDOWN WAVEFORMS

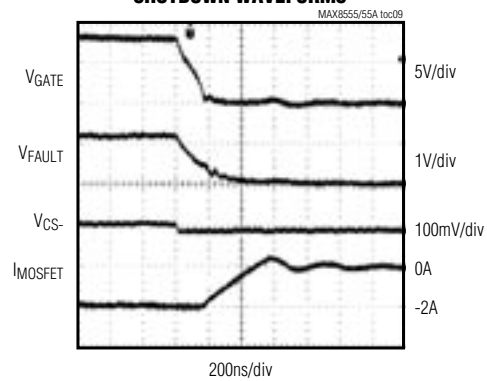

UVP SHUTDOWN WAVEFORMS

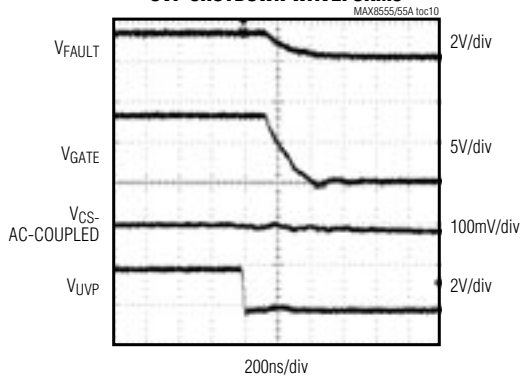

OVP SHUTDOWN WAVEFORMS

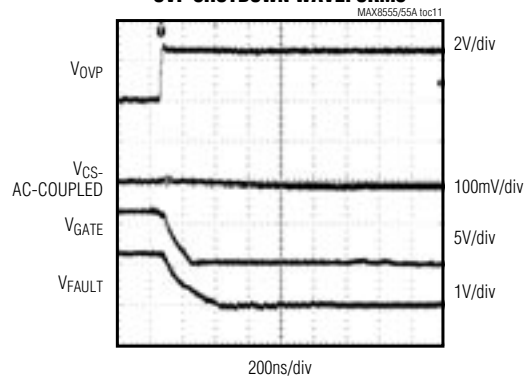

POWER-SUPPLY OUTPUT SHORT-CIRCUIT SHUTDOWN WAVEFORMS

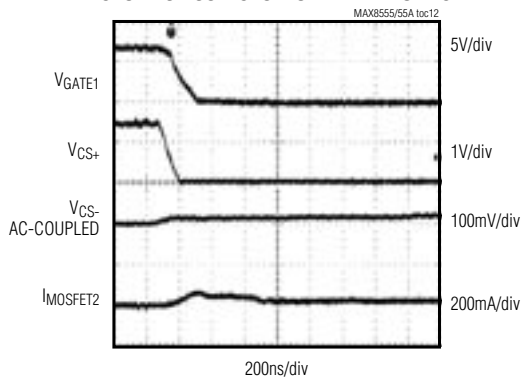

VDD FAULT SHUTDOWN WAVEFORMS

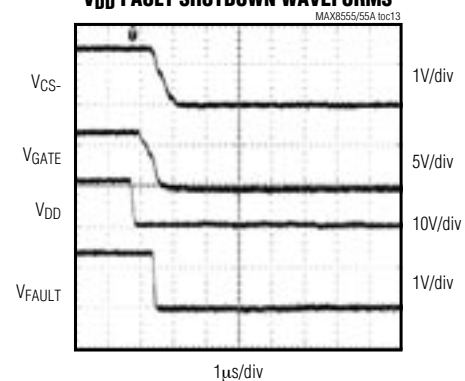

Low-Cost, High-Reliability, 0.5V to 3.3V ORing MOSFET Controllers

Pin Description

| PIN | NAME | FUNCTION |
|-----|---------------------------|---|
| 1 | GATE | Gate-Drive Output. Nominal GATE load is a 0.01 μ F capacitor to ground. Gate is discharged to GND in shutdown. |
| 2 | GND | Ground |
| 3 | VL | Low-Voltage Optional Input Power. Leave disconnected when $V_{DD} = 8V$ to 13.25V, or connect V_{DD} to VL when $V_{DD} = 3V$ to 5.5V. Bypass VL to GND with a 0.01 μ F capacitor. |
| 4 | V_{DD} | Power-Supply Input. Connect to an 8V to 13.25V supply or connect to VL when using a 3V to 5.5V supply. Bypass V_{DD} with a 0.01 μ F capacitor to ground. |
| 5 | UVP | Undervoltage-Protection Input. Connect UVP to the center of a resistor-divider from CS+ to GND. Connect UVP to VL to disable the undervoltage protection. |
| 6 | TIMER | Timer Input. Connect a resistor from TIMER to GND to select the charge-pump operating frequency. Drive TIMER low (< 0.5V) to disable the gate drive. Drive TIMER high (above 1.5V) for charge-pump operation at 550kHz. |
| 7 | $\overline{\text{FAULT}}$ | Open-Drain Fault Output. $\overline{\text{FAULT}}$ is high impedance during normal operation and is pulled to GND when a fault condition occurs. Connect a pullup resistor of 10k Ω or higher value (50k Ω typ) to a voltage rail of 5.5V or lower. |
| 8 | OVP | Overvoltage-Protection Input. Connect OVP to the center of a resistor-divider from the output bus to GND. Connect OVP to GND to disable the overvoltage protection. |
| 9 | CS- | Current-Sensing Input. Connect CS- to the positive side of the system bus. Bypass with a 1000pF capacitor to GND. |
| 10 | CS+ | Current-Sensing Input. Connect CS+ to the positive side of the input power. Bypass with a 1000pF capacitor to GND. |

Low-Cost, High-Reliability, 0.5V to 3.3V ORing MOSFET Controllers

MAX8555/MAX8555A

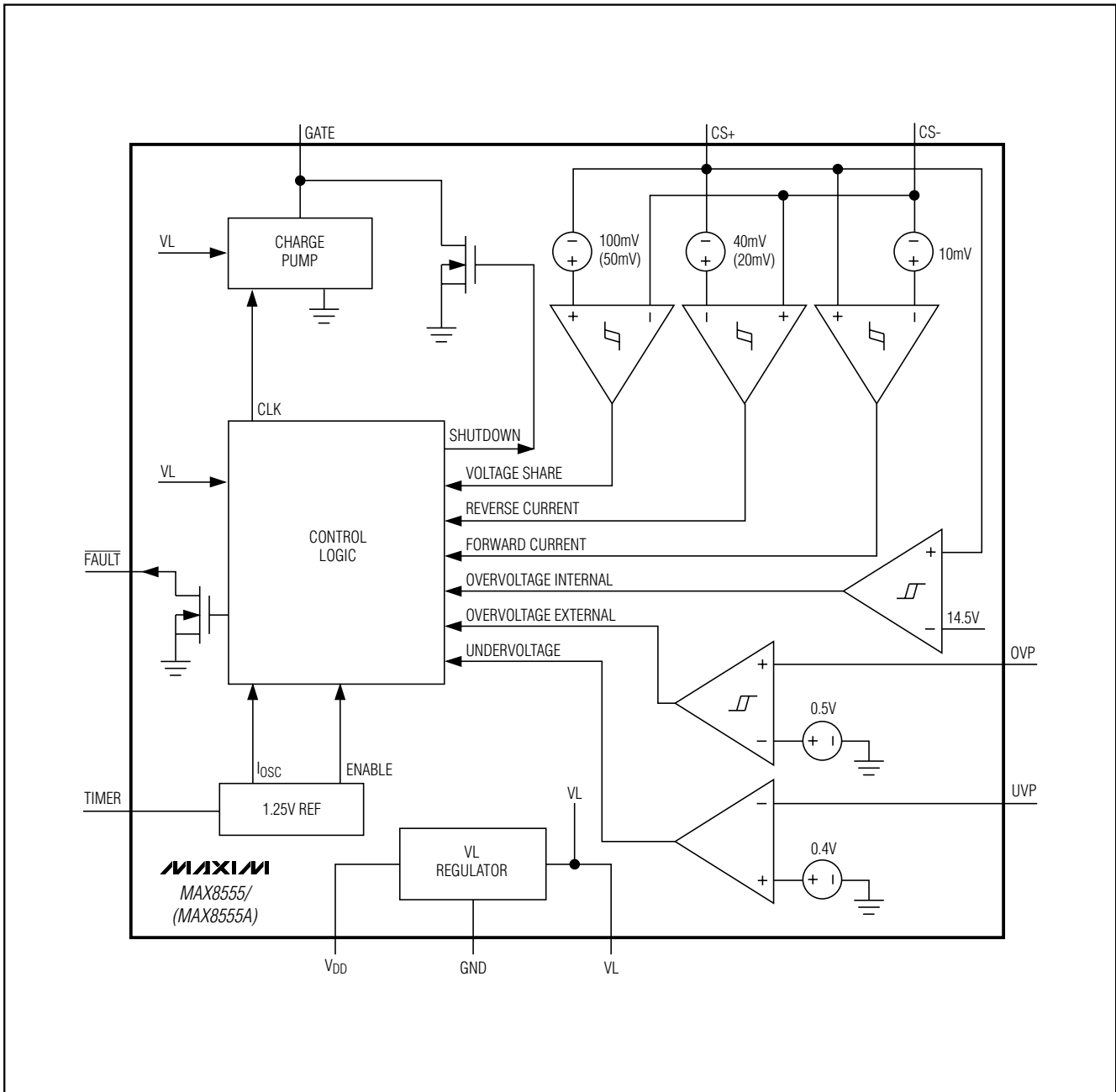
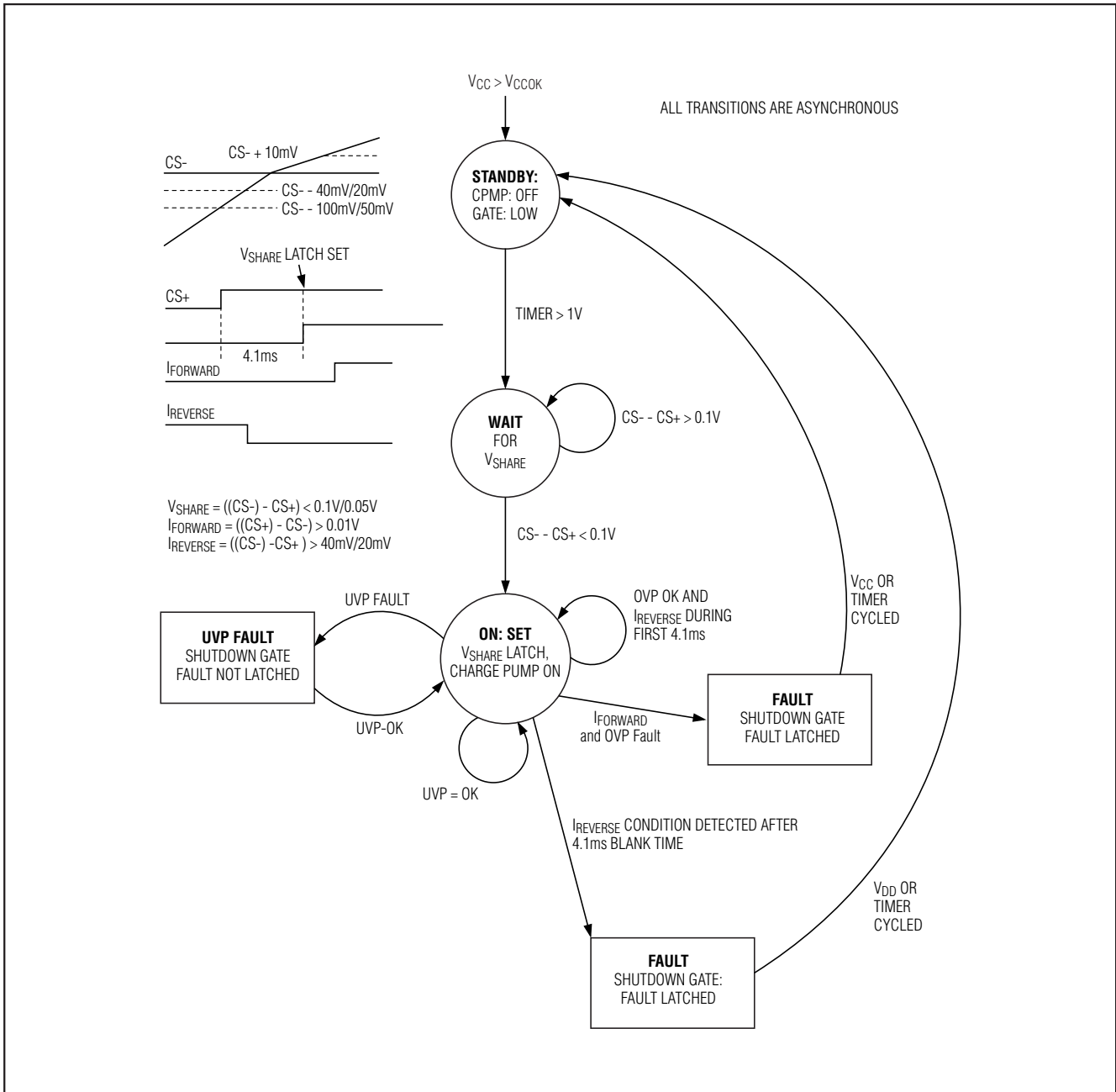

Figure 1. MAX8555/MAX8555A Functional Diagram

Low-Cost, High-Reliability, 0.5V to 3.3V ORing MOSFET Controllers

State Diagram



Low-Cost, High-Reliability, 0.5V to 3.3V ORing MOSFET Controllers

General Description

Critical loads often employ parallel-connected power supplies with redundancy to enhance system reliability. The MAX8555/MAX8555A are highly integrated, inexpensive MOSFET controllers that provide isolation and redundant power capability in high-reliability systems. The MAX8555/MAX8555A are used in 0.5V to 3.3V systems, and have an internal charge pump to drive the gates of the N-channel pass elements to $V_{CS+} + 5V$.

During startup, the MAX8555/MAX8555A monitor the voltage drop across the external MOSFETs. Once V_{CS+} approaches or exceeds the bus voltage (V_{CS-}), the MOSFETs are turned on. The MAX8555/MAX8555A feature a dual-purpose TIMER input. A single external resistor from TIMER to ground sets the turn-on speed of the external MOSFETs. Optionally, the TIMER input can be used as a logic enable input. Once the external MOSFET is turned on, these controllers monitor the load, protecting the bus against overvoltage, undervoltage, and reverse-current fault conditions. The MAX8555 is available with a 40mV reverse-current threshold, while the MAX8555A is available with a 20mV reverse-current threshold.

Overvoltage and undervoltage fault thresholds are adjustable and can be disabled. The current-limit trip points are set by the external MOSFETs' $R_{DS(ON)}$, reducing component count. An open-drain, logic-low fault output indicates if an overvoltage, undervoltage, or reverse-current fault occurs. The MAX8555 and the MAX8555A can shut down in response to a reverse-current fault condition as quickly as 200ns.

V_{DD}

V_{DD} is the power-supply input for the MAX8555/MAX8555A and the input to the internal preregulator. Bypass V_{DD} to GND with a 0.01 μ F capacitor. The input supply range for V_{DD} is 8V to 13.25V. The internal charge pump is disabled for input voltages above 14.4V (typ). For 3V to 5.5V input voltages, connect V_{DD} to VL.

VL

VL is the regulated power supply for the MAX8555/MAX8555A. The MAX8555/MAX8555A monitor VL at all times. During startup the device turns on when VL rises above V_{LOK} (2.82V typ). After V_{VL} exceeds V_{LOK} and V_{CS+} is typically greater than ($V_{CS-} - 100mV$), the charge pump turns on and drives GATE high, turning on the external MOSFETs. For operation from 3V to 5.5V input supplies, connect VL to V_{DD} .

TIMER

GATE is the output of the internal charge pump that drives the external MOSFETs. During startup, the voltage at GATE ramps up according to the charge-pump frequency. At 250kHz, the GATE drive current for the MAX8555/MAX8555A is 12 μ A. Increasing the charge-pump frequency increases the GATE drive current. To change charge-pump frequency, change the value of R_{TIMER} . See the *Selecting the TIMER Resistor* section.

CS+, CS-

The voltage drop across the external MOSFETs is measured between the CS+ and CS- inputs. CS+ connects to the positive side of the input voltage. CS- connects to the positive side of the system bus. The MAX8555/MAX8555A use the voltage drop across CS+ and CS- to determine operating mode. I_{FORWARD} is defined as $V_{CS+} - V_{CS-}$ and must be greater than 0.01V (typ) to properly detect an overvoltage fault condition. I_{REVERSE} is defined as $V_{CS-} - V_{CS+}$ and must be greater than 0.02V (MAX8555A) or 0.04V (MAX8555) (typ) for a reverse-current fault. The I_{FORWARD} and I_{REVERSE} thresholds can be effectively increased by placing an external divider such as R8 and R9 as shown in Figure 4. The values shown increase the thresholds by 50%. When R8 and R9 are used, also add R10 (a parallel combination of R8 and R9) to eliminate any input offset errors caused by impedance differences and input-bias-current differences.

Fault Conditions

The MAX8555/MAX8555A have an open-drain FAULT output that signals overvoltage, undervoltage, or reverse-current fault conditions. During a fault condition, \overline{FAULT} is pulled to GND, the charge pump shuts down, and GATE discharges to CS- in 200ns (typ). See Table 1 for fault modes.

Undervoltage Fault

The MAX8555/MAX8555A turn off the external MOSFETs if V_{UVP} falls below the UVP threshold (0.4V). Connect UVP to the center of a resistor-divider from the input supply to GND. Once V_{UVP} rises above the UVP rising threshold (0.5V), FAULT clears and GATE is driven high. FAULT is not latched. Connect UVP to VL to disable the undervoltage-protection feature.

Overvoltage Fault

The MAX8555/MAX8555A are protected from overvoltage conditions using an adjustable overvoltage-protection input. A resistor-divider from the output bus to GND with OVP connected to the center tap sets the overvoltage threshold. When V_{OVP} exceeds the OVP threshold (0.5V) and the device is in the I_{FORWARD} condition

Low-Cost, High-Reliability, 0.5V to 3.3V ORing MOSFET Controllers

Table 1. Fault Modes

| FAULT MODE | CONDITIONS | GATE | FAULT | LATCHING |
|---|--|------|----------------|----------|
| VL UVLO | $V_L < V_{L0K}$ | LOW | High Impedance | NO |
| UVP Undervoltage Protection | $V_{UVP} < 0.4V$ | LOW | LOW | NO |
| OVP Overvoltage Protection | $V_{OVP} > 0.5V$ $V_{CS+} > V_{CS-} + 0.01V$ | LOW | LOW | YES |
| Reverse-Current Protection | $V_{CS+} < V_{CS-} - 0.04V$ (0.02V for MAX8555A) and GATE is on for > 2048 charge-pump cycles | LOW | LOW | YES |
| V _{DD} Internal Overvoltage Protection | $V_{DD} > 14.5V$ | LOW | LOW | NO |

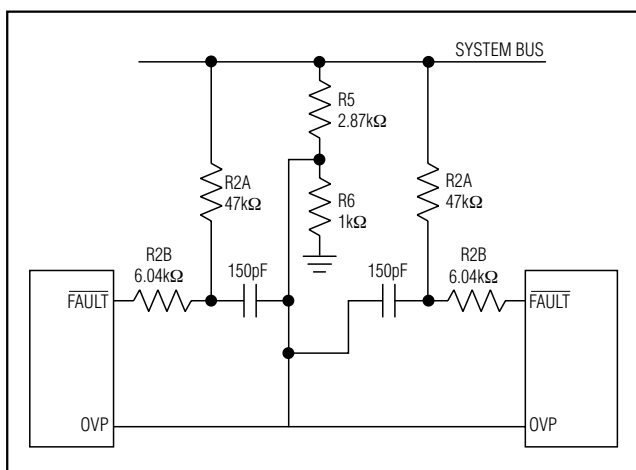

Figure 2. OVP Connection when Multiple MAX8555s Are Used

(defined as $V_{CS+} > V_{CS-} + 0.01V$), the MAX8555/MAX8555A discharge GATE to GND and FAULT is latched low. If the I_{FORWARD} condition is not detected, OVP is disabled. In redundant systems, when one input supply approaches its OVP threshold, some of the other input supplies may be pulled up with it, thereby tripping those OVP comparators with a slightly lower set point. The I_{FORWARD} condition for the pulled-up supplies may not be detected until the first supply is shut down. An alternate application schematic for FAULT and OVP is shown in Figure 2. The FAULT output of the first channel, which has both OVP and I_{FORWARD} conditions, temporarily reduces the common OVP signal by 125mV. This ensures that only the input supply, which is causing the overvoltage condition, is turned off in a redundant power-system application. Exceeding the OVP threshold causes the MAX8555/MAX8555A to be latched off. Toggle V_{DD} or TIMER to reset the IC. Connect OVP to GND to disable the overvoltage-protection feature.

Reverse-Current Fault

The MAX8555/MAX8555A provide a reverse-current fault-protection feature that turns off the oring MOSFET when a reverse-current fault condition is detected. Once a reverse-current fault condition is detected, the MAX8555/MAX8555A discharge GATE to GND and latch FAULT low. Toggle V_{DD}, VL, or TIMER to reset the IC. The reverse-current-protection feature is blanked for 2048 charge-pump cycles at startup.

Selecting the TIMER Resistor

Connect a resistor from TIMER to GND to set the internal charge pump's frequency of operation. Determine the TIMER resistor with the following equation:

$$R_{\text{TIMER}} = \frac{1.25V}{100\mu A - \frac{f}{5\text{kHz}/\mu A}}$$

Drive TIMER above 1.5V for the maximum charge-pump frequency (550kHz). Drive TIMER below 0.5V to disable the charge pump and shut down the MAX8555/MAX8555A.

Selecting the GATE Capacitor and GATE Resistor

The charge pump uses an internal monolithic transfer capacitor to charge the external MOSFET gates. Normally, the external MOSFET's gate capacitance is sufficient to serve as a reservoir capacitor. To slow down turn-on times further, add a small capacitor between GATE and GND. Adding a small resistor between GATE and the gate of the Oring MOSFET reduces the high-frequency ringing due to gate trace inductance. However, the resistor increases the turn-off time.

Low-Cost, High-Reliability, 0.5V to 3.3V ORing MOSFET Controllers

Applications Information

MAX8555/MAX8555A

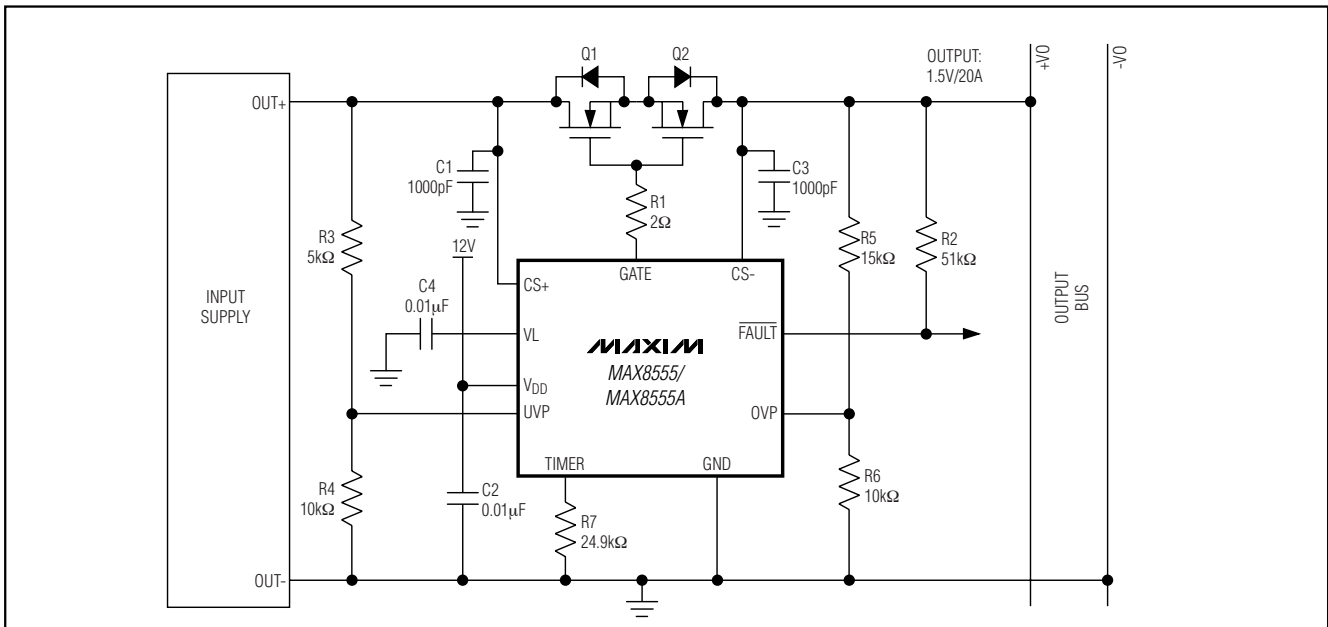

Figure 3. Application Circuit for 12V IC Supply Voltage

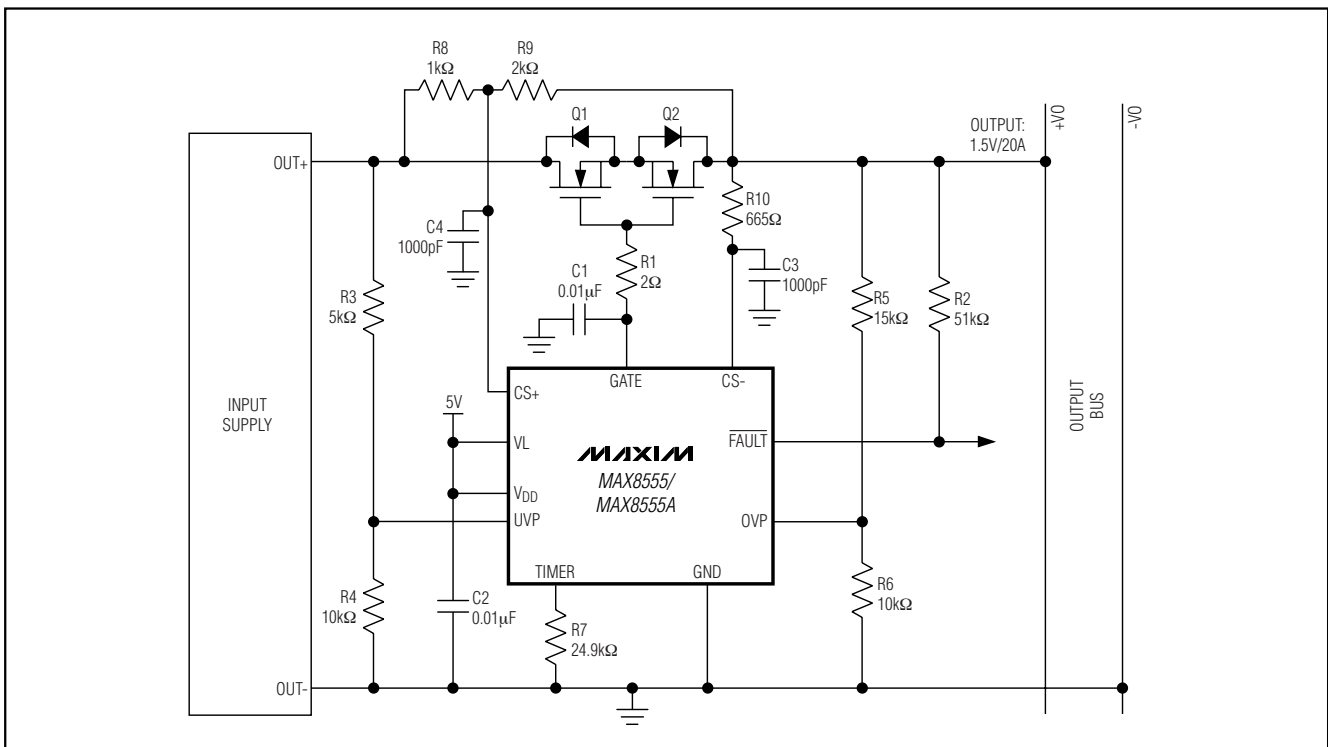

Figure 4. Application Circuit for 5V IC Supply Voltage

Low-Cost, High-Reliability, 0.5V to 3.3V ORing MOSFET Controllers

Set the UVP Fault Threshold

Use a resistor-divider from the input supply to GND with the center tap connected to UVP to set the undervoltage threshold. Use a 10kΩ resistor from UVP to GND (R4 in Figure 4) and calculate R3 as follows:

$$R_3 = R_4 \left(\frac{V_{UV}}{V_{UVP}} - 1 \right)$$

where V_{UV} is the desired undervoltage trip point and V_{UVP} is the UVP reference threshold (0.4V typ). Connect UVP to VL to disable the undervoltage-protection feature.

Set the OVP Fault Threshold

For a single-supply application, use a resistor-divider from the output bus to GND with the center tap connected to OVP to set the overvoltage threshold. Use a 10kΩ resistor from OVP to GND (R6 in Figure 4) and calculate R5 as follows:

$$R_5 = R_6 \left(\frac{V_{OV}}{V_{OVP}} - 1 \right)$$

where V_{OV} is the desired overvoltage threshold and V_{OVP} is the OVP reference threshold (0.5V typ). Connect OVP to GND to disable the overvoltage-protection feature.

For (n + 1) applications, the required circuit values are:

$$R_6 = 1k\Omega$$

$$R_5 = R_6 \times \left[\frac{V_{OV}}{V_{OVP}} - 1 \right]$$

$$R_2A = 47k\Omega$$

$$R_2B = 2 \times R_5$$

where the resistors are as shown in Figure 2.

MOSFET Selection

The MAX8555/MAX8555A drive N-channel MOSFETs. The most important specification of the MOSFETs is $R_{DS(ON)}$. As load current flows through the external MOSFET, V_{DS} is generated from source to drain due to the MOSFET's on-resistance, $R_{DS(ON)}$. The MAX8555/MAX8555A monitor V_{DS} of the MOSFETs at all times to determine the state of the monitored power supply. Selecting a MOSFET with a low $R_{DS(ON)}$ allows more current to flow through the MOSFETs before the MAX8555/MAX8555A detect reverse-current (IREVERSE) and forward-current (IFORWARD) conditions.

Using Two MOSFETs

Two MOSFETs must be used for overvoltage protection. When using two external MOSFETs, the monitored voltage equation becomes:

$$V_{DSTOTAL} = R_{DS(ON)1} \times I_{LOAD} + R_{DS(ON)2} \times I_{LOAD}$$

Using One MOSFET

A single MOSFET can be used if the overvoltage-protection function is not needed. Connect CS+ to the source of the MOSFET and CS- to the drain of the MOSFET.

Calculating GATE Current

The charge-pump output current is proportional to both oscillator frequency and V_{VL} . There is also a small internal load of approximately 6MΩ. The GATE current for a given V_{VL} and R_{TIMER} is calculated as:

$$I_{GATE} \approx \left\{ 24.12 \times \left[\frac{(V_L - 0.8)}{3.4} \right] \times \left[1 - \left[\frac{12,500}{R_{TIMER}} \right] \right] - 0.4 \right\} \mu A$$

Layout Guidelines

It is important to keep all traces as short as possible and to maximize the high-current trace dimensions to reduce the effect of undesirable parasitic inductance. The MOSFET dissipates a fair amount of heat due to the high currents involved, especially during an over-current condition. To dissipate the heat generated by the MOSFET, make the power traces very wide with a large amount of copper area and place the MAX8555 as close as possible to the drain of the external MOSFET. A more efficient way to achieve good power dissipation on a surface-mount package is to lay out two copper pads directly under the MOSFET package on both sides of the board. Use enlarged copper mounting pads on the top side of the board. Use a ground plane to minimize impedance and inductance. In addition to the usual high-power considerations, here are three tips to prevent false faults:

- 1) Kelvin connect CS+ and CS- to the external MOSFET and route the two traces in parallel, as close as possible, back to the IC.
- 2) Bypass V_{DD} with a 0.01μF capacitor to ground and bypass CS+ and CS- with a 1000pF capacitor to ground.
- 3) Make the traces connected to UVP and OVP as short as possible.

Refer to the MAX8555/MAX8555A evaluation kit for an example of good PC board layout.

Low-Cost, High-Reliability, 0.5V to 3.3V ORing MOSFET Controllers

Typical Operating Circuit

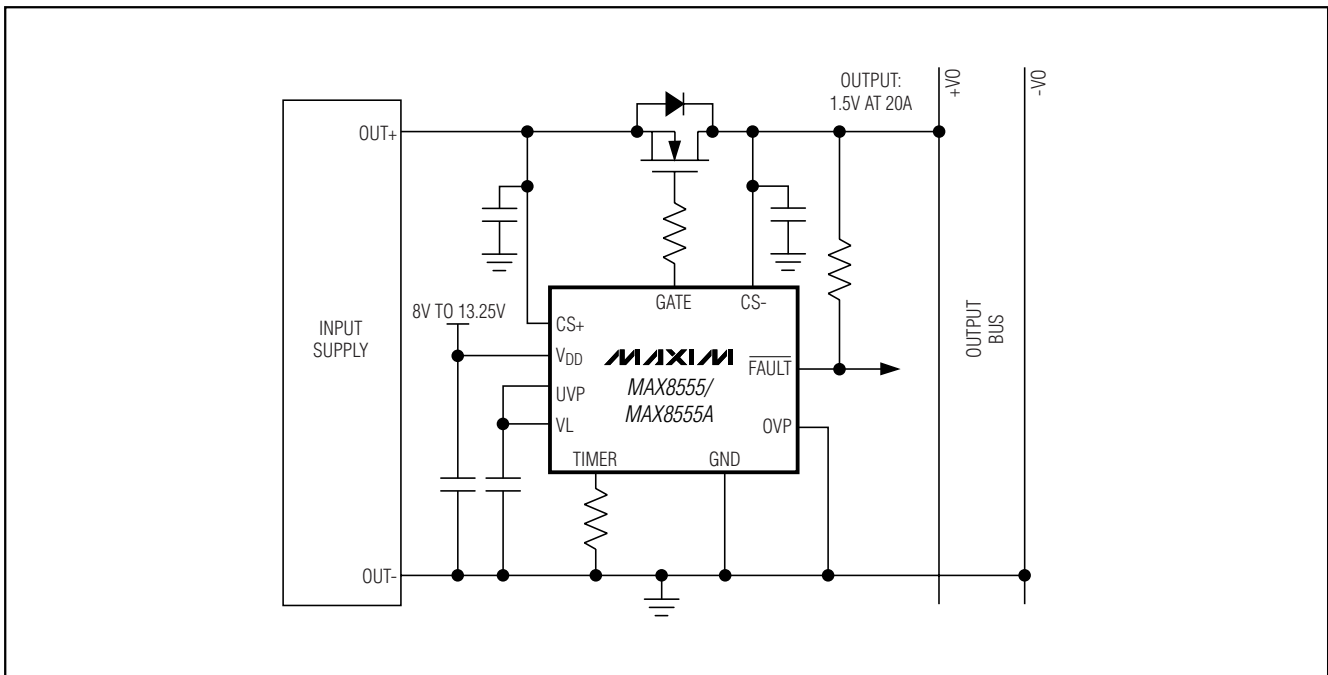

MAX8555/MAX8555A

Chip Information

TRANSISTOR COUNT: 2309

PROCESS: BiCMOS

Low-Cost, High-Reliability, 0.5V to 3.3V ORing MOSFET Controllers

Package Information

(The package drawing(s) in this data sheet may not reflect the most current specifications. For the latest package outline information, go to www.maxim-ic.com/packages.)

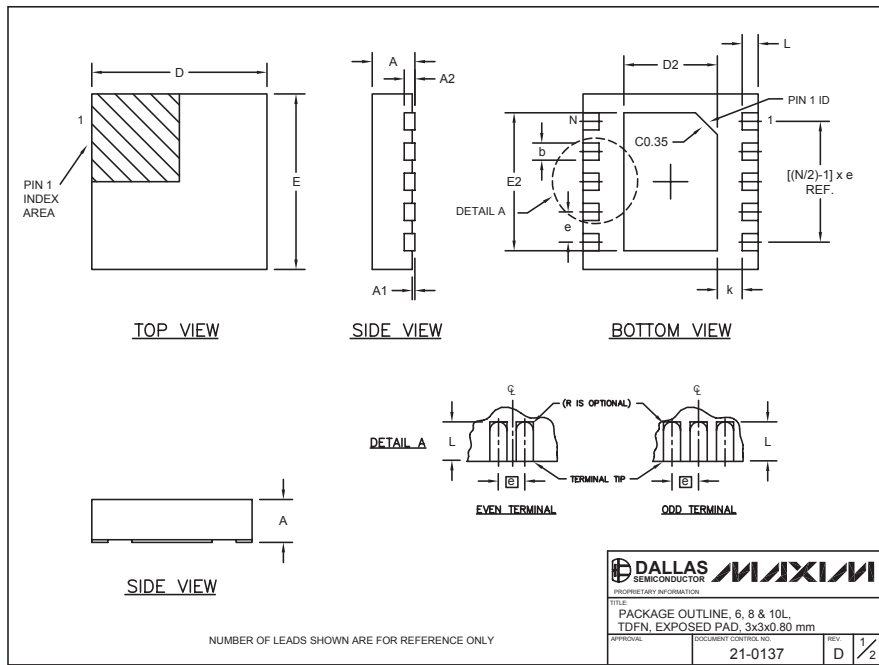

6, 8, & 10L, DFN THIN.EPS

| COMMON DIMENSIONS | | |
|-------------------|-----------|------|
| SYMBOL | MIN. | MAX. |
| A | 0.70 | 0.80 |
| D | 2.90 | 3.10 |
| E | 2.90 | 3.10 |
| A1 | 0.00 | 0.05 |
| L | 0.20 | 0.40 |
| k | 0.25 MIN. | |
| A2 | 0.20 REF. | |

| PACKAGE VARIATIONS | | | | | | | |
|--------------------|----|-----------|-----------|----------|----------------|-----------|---------------|
| PKG. CODE | N | D2 | E2 | e | JEDEC SPEC | b | [(N/2)-1] x e |
| T633-1 | 6 | 1.50±0.10 | 2.30±0.10 | 0.95 BSC | MO229 / WEEA | 0.40±0.05 | 1.90 REF |
| T833-1 | 8 | 1.50±0.10 | 2.30±0.10 | 0.65 BSC | MO229 / WEEC | 0.30±0.05 | 1.95 REF |
| T1033-1 | 10 | 1.50±0.10 | 2.30±0.10 | 0.50 BSC | MO229 / WEED-3 | 0.25±0.05 | 2.00 REF |

- NOTES:
- ALL DIMENSIONS ARE IN mm. ANGLES IN DEGREES.
 - COPLANARITY SHALL NOT EXCEED 0.08 mm.
 - WARPAGE SHALL NOT EXCEED 0.10 mm.
 - PACKAGE LENGTH/PACKAGE WIDTH ARE CONSIDERED AS SPECIAL CHARACTERISTIC(S).
 - DRAWING CONFORMS TO JEDEC MO229, EXCEPT DIMENSIONS "D2" AND "E2".
 - "N" IS THE TOTAL NUMBER OF LEADS.

DALLAS SEMICONDUCTOR MAXIM

PROPRIETARY INFORMATION

TITLE: PACKAGE OUTLINE, 6, 8 & 10L, TDFN, EXPOSED PAD, 3x3x0.80 mm

APPROVAL: DOCUMENT CONTROL NO: 21-0137 REV: D 2/2

Low-Cost, High-Reliability, 0.5V to 3.3V ORing MOSFET Controllers

Package Information (continued)

(The package drawing(s) in this data sheet may not reflect the most current specifications. For the latest package outline information, go to www.maxim-ic.com/packages.)

MAX8555/MAX8555A

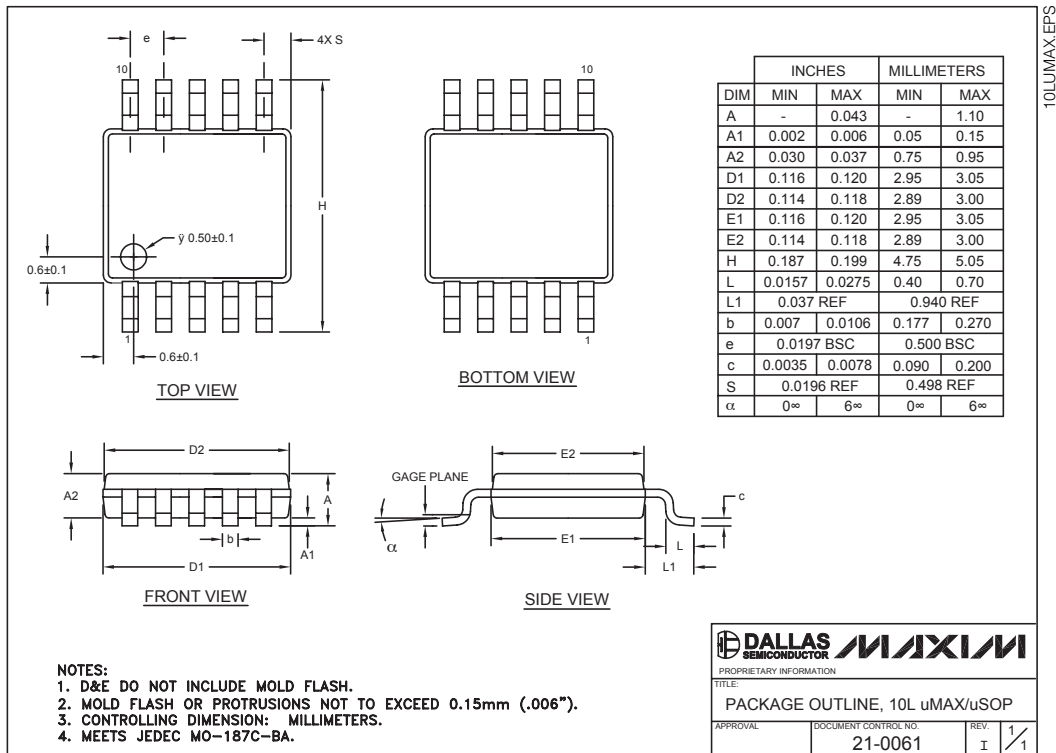

Maxim cannot assume responsibility for use of any circuitry other than circuitry entirely embodied in a Maxim product. No circuit patent licenses are implied. Maxim reserves the right to change the circuitry and specifications without notice at any time.