

### TFT-LCD Power Supply

The EL7585A represents a multiple output regulators for use in all large panel, TFT-LCD applications. It features a single boost converter with integrated 3.5A FET, two positive LDOs for  $V_{ON}$  and  $V_{LOGIC}$  generation, and a single negative LDO for  $V_{OFF}$  generation. The boost converter can be programmed to operate in either P-mode or PI-mode for improved load regulation.

The EL7585A also integrates fault protection for all four channels. Once a fault is detected, the device is latched off until the input supply or EN is cycled. This device also features an integrated start-up sequence for  $V_{BOOST}$ ,  $V_{OFF}$ , then  $V_{ON}$  or for  $V_{OFF}$ ,  $V_{BOOST}$ , and  $V_{ON}$  sequencing. The latter requires a single external transistor. The timing of the start-up sequence is set using an external capacitor. The  $V_{LOGIC}$  output is constantly enabled, but does shut down when a fault condition is detected.

The EL7585A is specified for operation over the  $-40^{\circ}\text{C}$  to  $+85^{\circ}\text{C}$  temperature range.

### Pinout

EL7585A  
(20 LD QFN)  
TOP VIEW

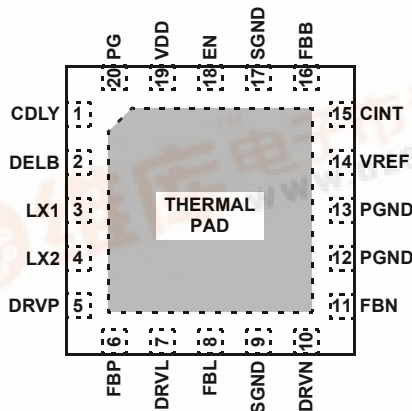

### Features

- 3.5A current limit FET options
- 3V to 5V input
- Up to 20V boost out
- 1% regulation on all outputs
- $V_{OFF}$ - $V_{BOOST}$ - $V_{ON}$  or  $V_{BOOST}$ - $V_{OFF}$ - $V_{ON}$  sequence control
  - $V_{LOGIC}$  is on from start-up for EL7585A
- Programmable sequence delay
- Fully fault protected
- Thermal shutdown
- Internal soft-start
- 20 Ld QFN packages
- Pb-free plus anneal available (RoHS compliant)

### Applications

- LCD monitors (15"+)
- LCD-TV (up to 40"+)
- Notebook displays (up to 16")
- Industrial/medical LCD displays

### Ordering Information

PART NUMBER	PART MARKING	PACKAGE	TAPE & REEL	PKG. DWG. #
EL7585AILZ (Note)	EL7585AIL Z	20 Ld 4x4 QFN (Pb-free)	-	MDP0046
EL7585AILZ-T7 (Note)	EL7585AIL Z	20 Ld 4x4 QFN (Pb-free)	7"	MDP0046
EL7585AILZ-T13 (Note)	EL7585AIL Z	20 Ld 4x4 QFN (Pb-free)	13"	MDP0046

NOTE: Intersil Pb-free plus anneal products employ special Pb-free material sets; molding compounds/die attach materials and 100% matte tin plate termination finish, which are RoHS compliant and compatible with both SnPb and Pb-free soldering operations. Intersil Pb-free products are MSL classified at Pb-free peak reflow temperatures that meet or exceed the Pb-free requirements of IPC/JEDEC J STD-020.



# EL7585A

## Absolute Maximum Ratings (T<sub>A</sub> = 25°C)

V <sub>DRVP</sub> .....	36V	V <sub>DRVL</sub> .....	6.5V
V <sub>DRVN</sub> .....	-20V	Storage Temperature .....	-65°C to +150°C
V <sub>DD</sub> .....	6.5V	Ambient Operating Temperature .....	-40°C to +85°C
V <sub>DELB</sub> , V <sub>LX</sub> .....	24V	Power Dissipation .....	See Curves
		Maximum continuous junction temperature .....	125°C

CAUTION: Stresses above those listed in "Absolute Maximum Ratings" may cause permanent damage to the device. This is a stress only rating and operation of the device at these or any other conditions above those indicated in the operational sections of this specification is not implied.

IMPORTANT NOTE: All parameters having Min/Max specifications are guaranteed. Typical values are for information purposes only. Unless otherwise noted, all tests are at the specified temperature and are pulsed tests, therefore: T<sub>J</sub> = T<sub>C</sub> = T<sub>A</sub>

**Electrical Specifications** V<sub>DD</sub> = 5V, V<sub>BOOST</sub> = 11V, I<sub>LOAD</sub> = 200mA, V<sub>ON</sub> = 15V, V<sub>OFF</sub> = -5V, V<sub>LOGIC</sub> = 2.5V, over temperature from -40°C to 85°C, unless otherwise specified.

PARAMETER	DESCRIPTION	CONDITION	MIN	TYP	MAX	UNIT
<b>SUPPLY</b>						
V <sub>S</sub>	Supply Voltage		3		5.5	V
I <sub>S</sub>	Quiescent Current	Enabled, LX not switching		1.7	2.5	mA
		Disabled		700	900	µA
<b>CLOCK</b>						
F <sub>OSC</sub>	Oscillator Frequency		900	1000	1100	kHz
<b>BOOST</b>						
V <sub>BOOST</sub>	Boost Output Range		5.5		20	V
V <sub>FBB</sub>	Boost Feedback Voltage	T <sub>A</sub> = 25°C	1.192	1.205	1.218	V
			1.188	1.205	1.222	V
V <sub>F_FBB</sub>	FBB Fault Trip Point			0.9		V
V <sub>REF</sub>	Reference Voltage	T <sub>A</sub> = 25°C	1.19	1.215	1.235	V
			1.187	1.215	1.238	V
C <sub>REF</sub>	V <sub>REF</sub> Capacitor		22	100		nF
D <sub>MAX</sub>	Maximum Duty Cycle		85			%
I <sub>LXMAX</sub>	Switch Current Limit			3.5		A
I <sub>LEAK</sub>	Switch Leakage Current	V <sub>LX</sub> = 16V			10	µA
r <sub>DS(ON)</sub>	Switch On-Resistance			160		mΩ
Eff	Boost Efficiency	See curves		92		%
I(V <sub>FBB</sub> )	Feedback Input Bias Current	PI mode, V <sub>FBB</sub> = 1.35V		50	500	nA
ΔV <sub>BOOST</sub> /ΔV <sub>IN</sub>	Line Regulation	C <sub>INT</sub> = 4.7nF, I <sub>OUT</sub> = 100mA, V <sub>IN</sub> = 3V to 5.5V		0.05		%/V
ΔV <sub>BOOST</sub> /ΔI <sub>BOOST</sub>	Load Regulation - "P" mode	C <sub>INT</sub> pin strapped to V <sub>DD</sub> , 50mA < I <sub>LOAD</sub> < 250mA		3		%
ΔV <sub>BOOST</sub> /ΔI <sub>BOOST</sub>	Load Regulation - "PI" mode	C <sub>INT</sub> = 4.7nF, 50mA < I <sub>O</sub> < 250mA		0.1		%
V <sub>CINT_T</sub>	CINT PI Mode Select Threshold			4.7	4.8	V
<b>V<sub>ON</sub> LDO</b>						
V <sub>FBP</sub>	FBP Regulation Voltage	I <sub>DRVP</sub> = 0.2mA, T <sub>A</sub> = 25°C	1.176	1.2	1.224	V
		I <sub>DRVP</sub> = 0.2mA	1.172	1.2	1.228	V
V <sub>F_FBP</sub>	FBP Fault Trip Point	V <sub>FBP</sub> falling	0.82	0.87	0.92	V
I <sub>FBP</sub>	FBP Input Bias Current	V <sub>FBP</sub> = 1.35V	-250		250	nA
GMP	FBP Effective Transconductance	V <sub>DRVP</sub> = 25V, I <sub>DRVP</sub> = 0.2 to 2mA		50		ms

## EL7585A

**Electrical Specifications**  $V_{DD} = 5V$ ,  $V_{BOOST} = 11V$ ,  $I_{LOAD} = 200mA$ ,  $V_{ON} = 15V$ ,  $V_{OFF} = -5V$ ,  $V_{LOGIC} = 2.5V$ , over temperature from  $-40^{\circ}C$  to  $85^{\circ}C$ , unless otherwise specified. **(Continued)**

PARAMETER	DESCRIPTION	CONDITION	MIN	TYP	MAX	UNIT
$\Delta V_{ON}/\Delta I(V_{ON})$	$V_{ON}$ Load Regulation	$I(V_{ON}) = 0mA$ to $20mA$		-0.5		%
$I_{DRVP}$	DRVP Sink Current Max	$V_{FBN} = 1.1V$ , $V_{DRVP} = 25V$	2	4		mA
$I_{L\_DRVP}$	DRVP Leakage Current	$V_{FBN} = 1.5V$ , $V_{DRVP} = 35V$		0.1	5	$\mu A$
<b><math>V_{OFF}</math> LDO</b>						
$V_{FBN}$	FBN Regulation Voltage	$I_{DRVN} = 0.2mA$ , $T_A = 25^{\circ}C$	0.173	0.203	0.233	V
		$I_{DRVN} = 0.2mA$	0.171	0.203	0.235	V
$V_{F\_FBN}$	FBN Fault Trip Point	$V_{FBN}$ rising	0.38	0.43	0.48	V
$I_{FBN}$	FBN Input Bias Current	$V_{FBN} = 0.2V$	-250		250	nA
GMN	FBN Effective Transconductance	$V_{DRVN} = -6V$ , $I_{DRVN} = 0.2mA$ to $2mA$		50		ms
$\Delta V_{OFF}/\Delta I(V_{OFF})$	$V_{OFF}$ Load Regulation	$I(V_{OFF}) = 0mA$ to $20mA$		-0.5		%
$I_{DRVN}$	DRVN Source Current Max	$V_{FBN} = 0.3V$ , $V_{DRVN} = -6V$	2	4		mA
$I_{L\_DRVN}$	DRVN Leakage Current	$V_{FBN} = 0V$ , $V_{DRVN} = -20V$		0.1	5	$\mu A$
<b><math>V_{LOGIC}</math> LDO</b>						
$V_{FBL}$	FBL Regulation Voltage	$I_{DRVL} = 1mA$ , $T_A = 25^{\circ}C$	1.176	1.2	1.224	V
		$I_{DRVL} = 1mA$	1.174	1.2	1.226	V
$V_{F\_FBL}$	FBL Fault Trip Point	$V_{FBL}$ falling	0.82	0.87	0.92	V
$I_{FBL}$	FBL Input Bias Current	$V_{FBL} = 1.35V$	-500		500	nA
GML	FBL Effective Transconductance	$V_{DRVL} = 2.5V$ , $I_{DRVL} = 1mA$ to $8mA$		200		ms
$\Delta V_{LOGIC}/\Delta I(V_{LOGIC})$	$V_{LOGIC}$ Load Regulation	$I(V_{LOGIC}) = 100mA$ to $500mA$		0.5		%
$I_{DRVL}$	DRVL Sink Current Max	$V_{FBL} = 1.1V$ , $V_{DRVL} = 2.5V$	8	16		mA
$I_{L\_DRL}$	$I_{L\_DRVL}$	$V_{FBL} = 1.5V$ , $V_{DRVL} = 5.5V$		0.1	5	$\mu A$
<b>SEQUENCING</b>						
$t_{ON}$	Turn On Delay	$C_{DLY} = 0.22\mu F$		30		ms
$t_{SS}$	Soft-start Time	$C_{DLY} = 0.22\mu F$		2		ms
$t_{DEL1}$	Delay Between $A_{VDD}$ and $V_{OFF}$	$C_{DLY} = 0.22\mu F$		10		ms
$t_{DEL2}$	Delay Between $V_{ON}$ and $V_{OFF}$	$C_{DLY} = 0.22\mu F$		17		ms
$t_{DEL3}$	Delay Between $V_{OFF}$ and Delayed $V_{BOOST}$	$C_{DLY} = 0.22\mu F$		10		ms
$I_{DEL B}$	DEL B Pull-down Current	$V_{DEL B} > 0.6V$		50		$\mu A$
		$V_{DEL B} < 0.6V$		1.4		mA
$C_{DEL}$	Delay Capacitor		10	220		nF
<b>FAULT DETECTION</b>						
$t_{FAULT}$	Fault Time Out	$C_{DLY} = 0.22\mu F$		50		ms
OT	Over-temperature Threshold			140		$^{\circ}C$
$I_{PG}$	PG Pull-down Current	$V_{PG} > 0.6V$		15		$\mu A$
		$V_{PG} < 0.6V$		1.7		mA
<b>LOGIC ENABLE</b>						
$V_{HI}$	Logic High Threshold		2.2			V
$V_{LO}$	Logic Low Threshold				0.8	V

## EL7585A

**Electrical Specifications**  $V_{DD} = 5V$ ,  $V_{BOOST} = 11V$ ,  $I_{LOAD} = 200mA$ ,  $V_{ON} = 15V$ ,  $V_{OFF} = -5V$ ,  $V_{LOGIC} = 2.5V$ , over temperature from  $-40^{\circ}C$  to  $85^{\circ}C$ , unless otherwise specified. **(Continued)**

PARAMETER	DESCRIPTION	CONDITION	MIN	TYP	MAX	UNIT
$I_{LOW}$	Logic Low bias Current			0.2	1	$\mu A$
$I_{HIGH}$	Logic High bias Current	at $V_{EN} = 5V$	12	18	24	$\mu A$

### Pin Descriptions

PIN NAME	PIN NUMBER	DESCRIPTION
1	CDLY	A capacitor connected from this pin to GND sets the delay time for start-up sequence and sets the fault timeout time
2	DELB	Gate drive of optional $V_{BOOST}$ delay FET
3, 4	LX1, LX2	Drain of the internal N channel boost FET; for EL7586, pin 4 is not connected
5	DRVP	Positive LDO base drive; open drain of an internal N channel FET
6	FBP	Positive LDO voltage feedback input pin; regulates to 1.2V nominal
7	DRVL	Logic LDO base drive; open drain of an internal N channel FET
8	FBL	Logic LDO voltage feedback input pin; regulates to 1.2V nominal
9, 17	SGND	Low noise signal ground
10	DRVN	Negative LDO base drive; open drain of an internal P channel FET
11	FBN	Negative LDO voltage feedback input pin; regulates to 0.2V nominal
12, 13	PGND	Power ground, connected to source of internal N channel boost FET
14	VREF	Bandgap voltage bypass, connect a $0.1\mu F$ to SGND
15	CINT	$V_{BOOST}$ integrator output, connect capacitor to SGND for PI mode or connect to $V_{DD}$ for P mode operation
16	FBB	Boost regulator voltage feedback input pin; regulates to 1.2V nominal
18	EN	Enable pin, High=Enable; Low or floating=Disable
19	VDD	Positive supply
20	PG	Gate drive of optional fault protection FET, when chip is disabled or when a fault has been detected, this is high

### Typical Performance Curves

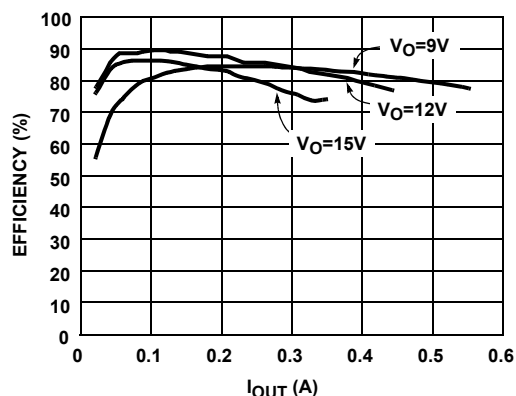

FIGURE 1.  $V_{BOOST}$  EFFICIENCY AT  $V_{IN}=3V$  (PI MODE)

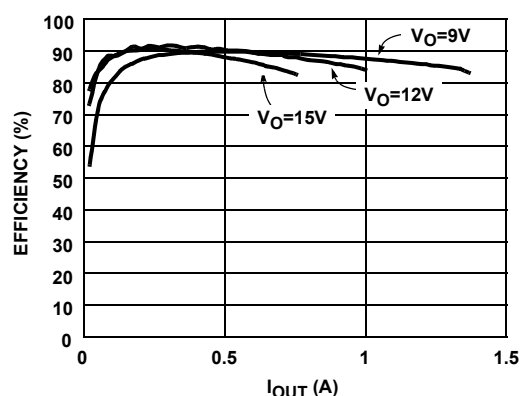

FIGURE 2.  $V_{BOOST}$  EFFICIENCY AT  $V_{IN}=5V$  (PI MODE)

Typical Performance Curves (Continued)

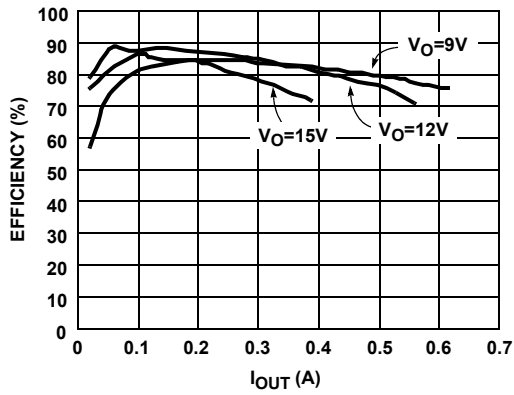

FIGURE 3. VBOOST EFFICIENCY AT  $V_{IN}=3V$  (P MODE)

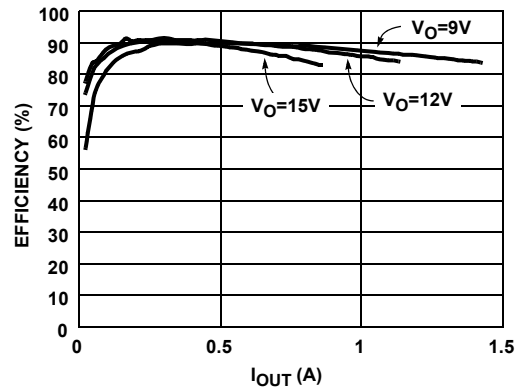

FIGURE 4. VBOOST EFFICIENCY AT  $V_{IN}=5V$  (P MODE)

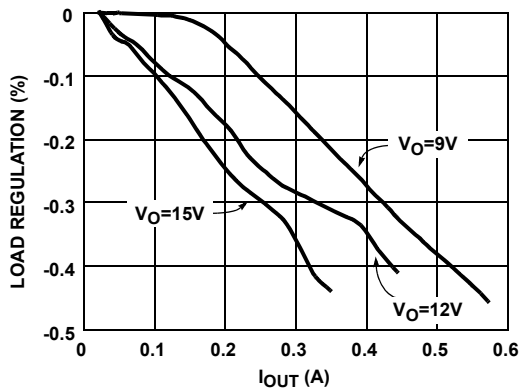

FIGURE 5. VBOOST LOAD REGULATION AT  $V_{IN}=3V$  (PI MODE)

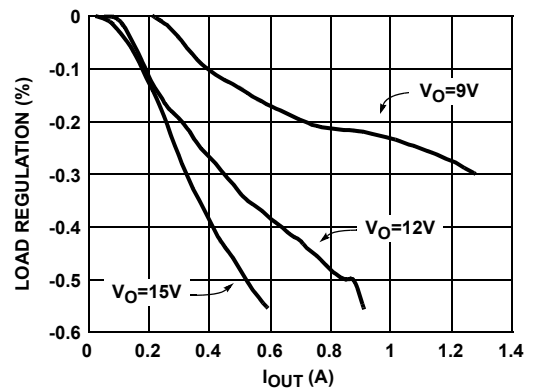

FIGURE 6. VBOOST LOAD REGULATION AT  $V_{IN}=5V$  (PI MODE)

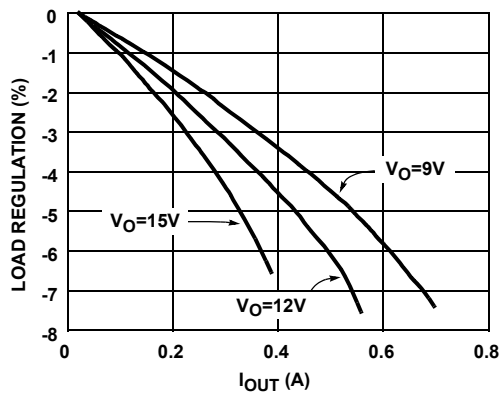

FIGURE 7. VBOOST LOAD REGULATION AT  $V_{IN}=3V$  (P MODE)

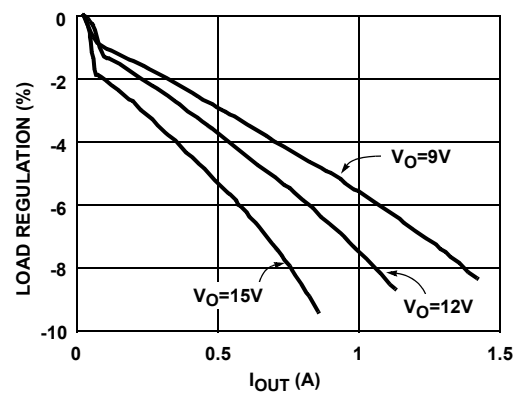

FIGURE 8. VBOOST LOAD REGULATION AT  $V_{IN}=5V$  (P MODE)

Typical Performance Curves (Continued)

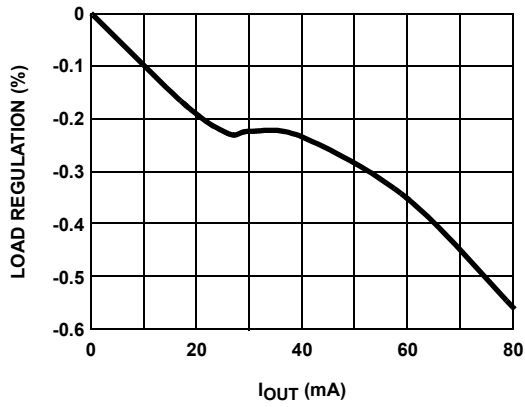

FIGURE 9. V<sub>ON</sub> LOAD REGULATION

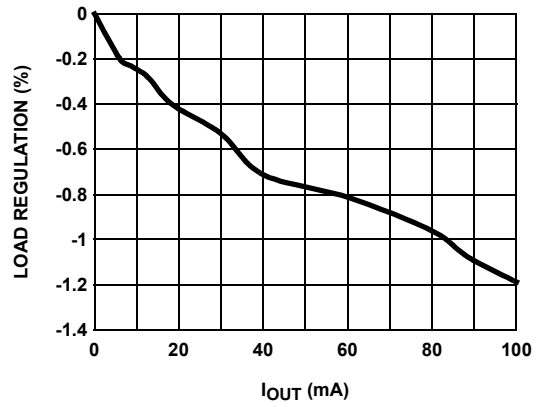

FIGURE 10. V<sub>OFF</sub> LOAD REGULATION

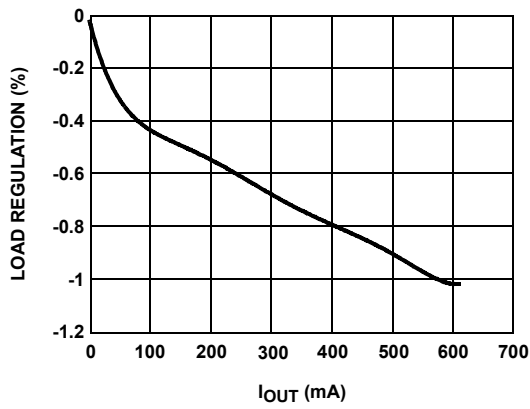

FIGURE 11. V<sub>LOGIC</sub> LOAD REGULATION

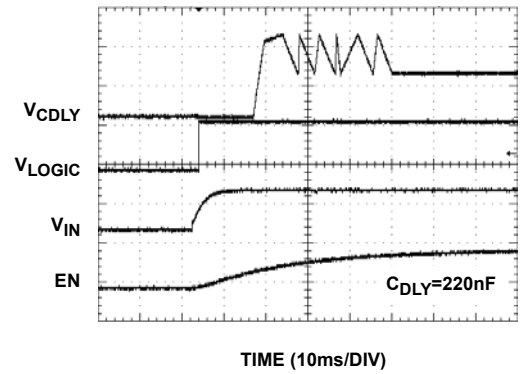

FIGURE 12. START-UP SEQUENCE

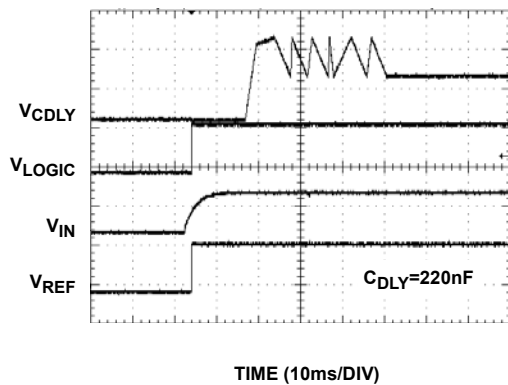

FIGURE 13. START-UP SEQUENCE

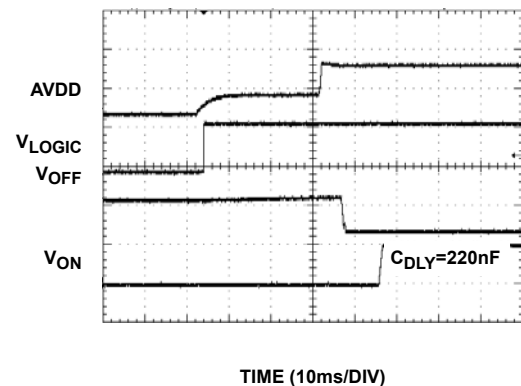

FIGURE 14. START-UP SEQUENCE

Typical Performance Curves (Continued)

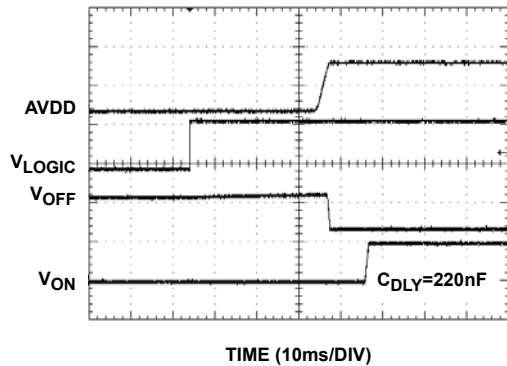

FIGURE 15. START-UP SEQUENCE

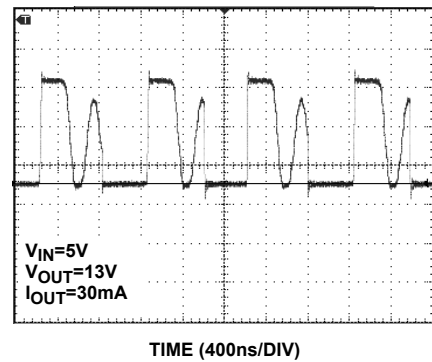

FIGURE 16. LX WAVEFORM - DISCONTINUOUS MODE

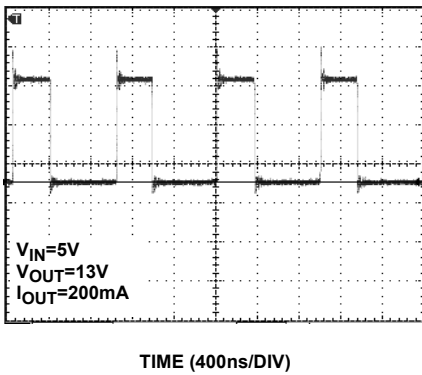

FIGURE 17. LX WAVEFORM - CONTINUOUS MODE

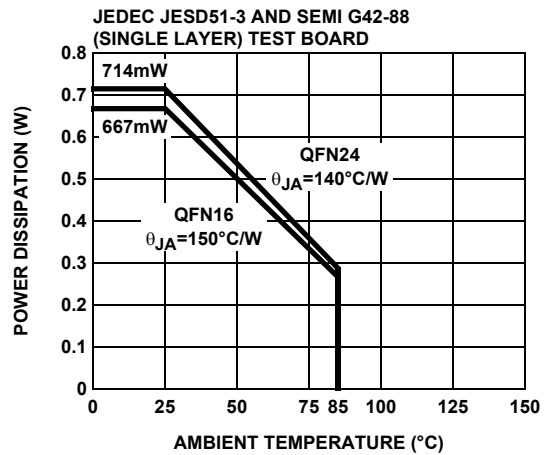

FIGURE 18. PACKAGE POWER DISSIPATION vs AMBIENT TEMPERATURE

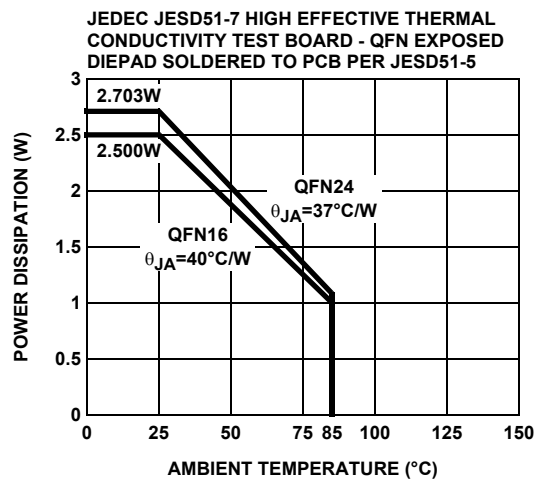

FIGURE 19. PACKAGE POWER DISSIPATION vs AMBIENT TEMPERATURE

# EL7585A

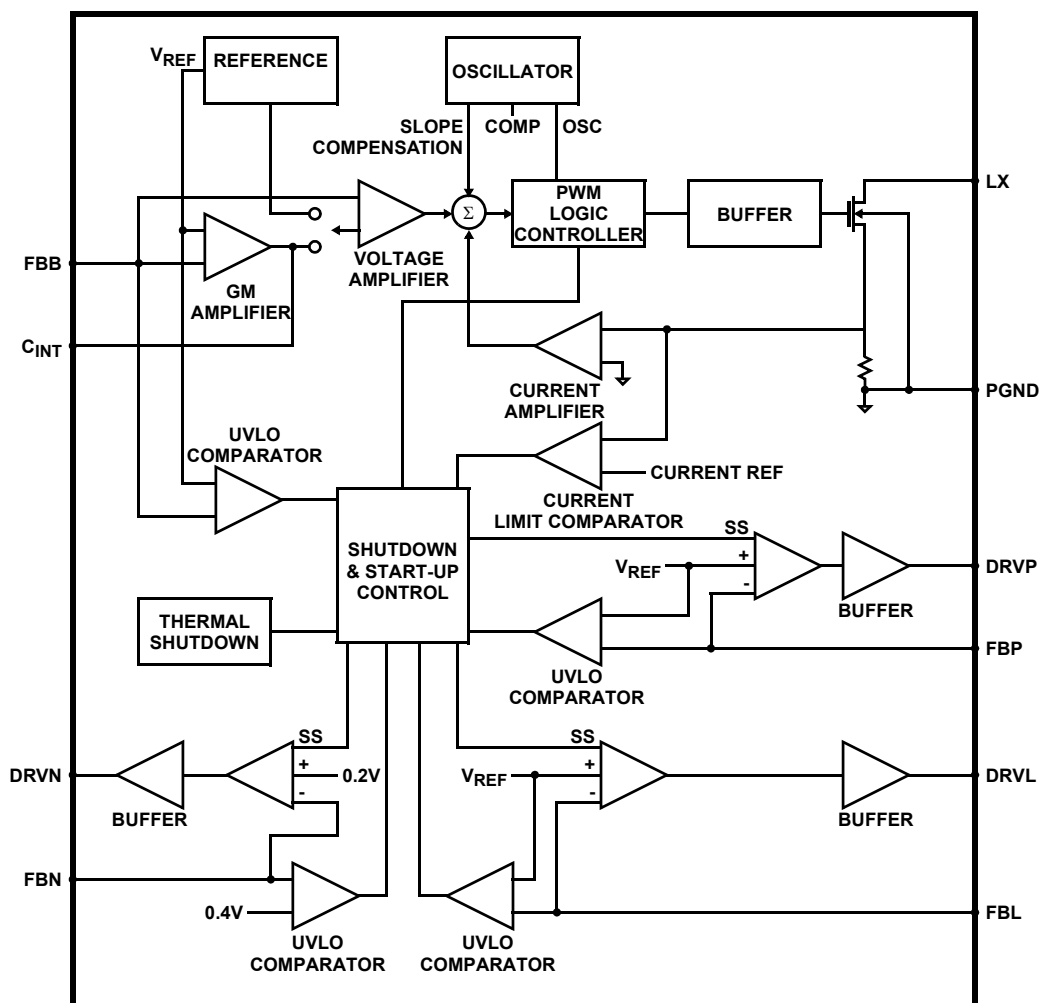

FIGURE 20. BLOCK DIAGRAM

## Applications Information

The EL7585A is a highly integrated multiple output power solution for TFT-LCD applications. The system consists of one high efficiency boost converter and three linear-regulator controllers ( $V_{ON}$ ,  $V_{OFF}$ , and  $V_{LOGIC}$ ) with multiple protection functions. A block diagram is shown in Figure 20. Table 1 lists the recommended components.

The EL7585A integrates an N-channel MOSFET boost converter to minimize external component count and cost. The  $A_{VDD}$ ,  $V_{ON}$ ,  $V_{OFF}$ , and  $V_{LOGIC}$  output voltages are independently set using external resistors.  $V_{ON}$ ,  $V_{OFF}$  voltages require external charge pumps which are post regulated using the integrated LDO controllers.

TABLE 1. RECOMMENDED COMPONENTS

DESIGNATION	DESCRIPTION
C <sub>1</sub> , C <sub>2</sub> , C <sub>3</sub>	10µF, 16V X5R ceramic capacitor (1206) TDK C3216X5R0J106K
C <sub>20</sub> , C <sub>31</sub>	4.7µF, 25V X5R ceramic capacitor (1206) TDK C3216X5R1A475K

TABLE 1. RECOMMENDED COMPONENTS (Continued)

DESIGNATION	DESCRIPTION
D <sub>1</sub>	1A 20V low leakage Schottky rectifier (CASE 457-04) ON SEMI MBRM120ET3
D <sub>11</sub> , D <sub>12</sub> , D <sub>21</sub>	200mA 30V Schottky barrier diode (SOT-23) Fairchild BAT54S
L <sub>1</sub>	6.8µH 1.3A Inductor TDK SLF6025T-6R8M1R3-PF
Q <sub>1</sub>	-2.4 -20V P-channel 1.8V specified PowerTrench MOSFET (SuperSOT-3) Fairchild FDN304P
Q <sub>4</sub>	-2A -30V single P-channel logic level PowerTrench MOSFET (SuperSOT-3) Fairchild FDN360P
Q <sub>3</sub>	200mA 40V PNP amplifier (SOT-23) Fairchild MMBT3906
Q <sub>2</sub>	200mA 40V NPN amplifier (SOT-23) Fairchild MMBT3904
Q <sub>5</sub>	1A 30V PNP low saturation amplifier (SOT-23) Fairchild FMMT549



## EL7585A

### Boost Converter

The main boost converter is a current mode PWM converter at a fixed frequency of 1MHz which enables the use of low profile inductors and multilayer ceramic capacitors. This results in a compact, low cost power system for LCD panel design.

The EL7585A is designed for continuous current mode, but they can also operate in discontinuous current mode at light load. In continuous current mode, current flows continuously in the inductor during the entire switching cycle in steady state operation. The voltage conversion ratio in continuous current mode is given by:

$$\frac{A_{VDD}}{V_{IN}} = \frac{1}{1-D}$$

Where D is the duty cycle of the switching MOSFET.

Figure 21 shows the block diagram of the boost regulator. It uses a summing amplifier architecture consisting of GM stages for voltage feedback, current feedback and slope compensation. A comparator looks at the peak inductor current cycle by cycle and terminates the PWM cycle if the current limit is reached.

An external resistor divider is required to divide the output voltage down to the nominal reference voltage. Current drawn by the resistor network should be limited to maintain the overall converter efficiency. The maximum value of the resistor network is limited by the feedback input bias current and the potential for noise being coupled into the feedback pin. A resistor network in the order of 60kΩ is recommended. The boost converter output voltage is determined by the following equation:

$$A_{VDD} = \frac{R_1 + R_2}{R_1} \times V_{REF}$$

The current through the MOSFET is limited to 3.5A peak. This restricts the maximum output current based on the following equation:

$$I_{OMAX} = \left( I_{LMT} - \frac{\Delta I_L}{2} \right) \times \frac{V_{IN}}{V_O}$$

Where  $\Delta I_L$  is peak to peak inductor ripple current, and is set by:

$$\Delta I_L = \frac{V_{IN}}{L} \times \frac{D}{f_S}$$

where  $f_S$  is the switching frequency.

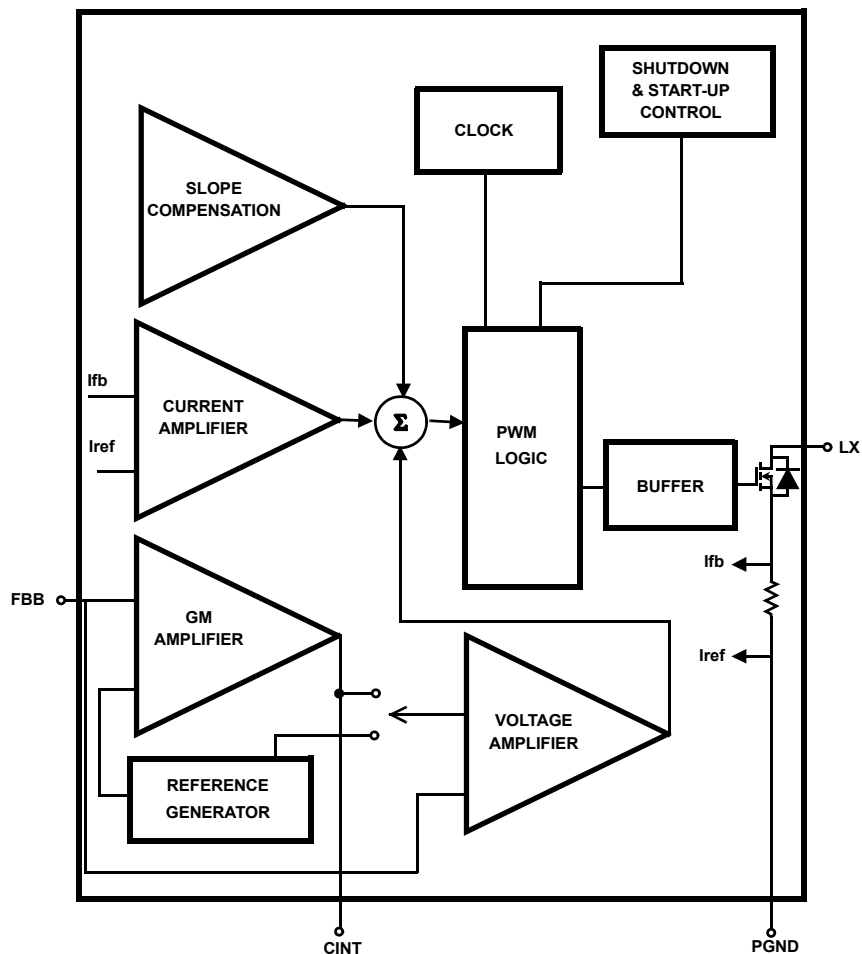

FIGURE 21. BLOCK DIAGRAM OF THE BOOST REGULATOR

## EL7585A

The following table gives typical values (margins are considered 10%, 3%, 20%, 10%, and 15% on  $V_{IN}$ ,  $V_O$ ,  $L$ ,  $f_S$ , and  $I_{OMAX}$ ):

TABLE 2.

$V_{IN}$ (V)	$V_O$ (V)	$L$ ( $\mu$ H)	$f_S$ (MHz)	$I_{OMAX}$
3.3	9	6.8	1	1.040686
3.3	12	6.8	1	0.719853
3.3	15	6.8	1	0.527353
5	9	6.8	1	1.576797
5	12	6.8	1	1.090686
5	15	6.8	1	0.79902

### Input Capacitor

An input capacitor is used to supply the peak charging current to the converter. It is recommended that  $C_{IN}$  be larger than  $10\mu$ F. The reflected ripple voltage will be smaller with larger  $C_{IN}$ . The voltage rating of input capacitor should be larger than maximum input voltage.

### Boost Inductor

The boost inductor is a critical part which influences the output voltage ripple, transient response, and efficiency. Values of  $3.3\mu$ H to  $10\mu$ H are to match the internal slope compensation. The inductor must be able to handle the following average and peak current:

$$I_{LAVG} = \frac{I_O}{1-D}$$

$$I_{LPK} = I_{LAVG} + \frac{\Delta I_L}{2}$$

### Rectifier Diode

A high-speed diode is necessary due to the high switching frequency. Schottky diodes are recommended because of their fast recovery time and low forward voltage. The rectifier diode must meet the output current and peak inductor current requirements.

### Output Capacitor

The output capacitor supplies the load directly and reduces the ripple voltage at the output. Output ripple voltage consists of two components: the voltage drop due to the inductor ripple current flowing through the ESR of output capacitor, and the charging and discharging of the output capacitor.

$$V_{RIPPLE} = I_{LPK} \times ESR + \frac{V_O - V_{IN}}{V_O} \times \frac{I_O}{C_{OUT}} \times \frac{1}{f_S}$$

For low ESR ceramic capacitors, the output ripple is dominated by the charging and discharging of the output

capacitor. The voltage rating of the output capacitor should be greater than the maximum output voltage.

NOTE: Capacitors have a voltage coefficient that makes their effective capacitance drop as the voltage across them increases.  $C_{OUT}$  in the equation above assumes the effective value of the capacitor at a particular voltage and not the manufacturer's stated value, measured at zero volts.

### Compensation

The EL7585A can operate in either P mode or PI mode. Connecting the  $C_{INT}$  pin directly to  $V_{IN}$  will enable P mode; For better load regulation, use PI mode with a  $4.7n$ F capacitor in series with a  $10K$  resistor between  $C_{INT}$  and ground. This value may be reduced to improve transient performance, however, very low values will reduce loop stability.

### Boost feedback resistors

As the boost output voltage,  $A_{VDD}$ , is reduced below  $12V$  the effective voltage feedback in the IC increases the ratio of voltage to current feedback at the summing comparator because  $R_2$  decreases relative to  $R_1$ . To maintain stable operation over the complete current range of the IC, the voltage feedback to the FBB pin should be reduced proportionally, as  $A_{VDD}$  is reduced, by means of a series resistor-capacitor network ( $R_7$  and  $C_7$ ) in parallel with  $R_1$ , with a pole frequency ( $f_p$ ) set to approximately  $10kHz$  for  $C_2$  effective =  $10\mu$ F and  $4kHz$  for  $C_2$  (effective) =  $30\mu$ F.

$$R_7 = ((1/0.1 \times R_2) - 1/R_1)^{-1}$$

$$C_7 = 1/(2 \times 3.142 \times f_p \times R_7)$$

### PI mode $C_{INT}$ ( $C_{23}$ ) and $R_{INT}$ ( $R_{10}$ )

The IC is designed to operate with a minimum  $C_{23}$  capacitor of  $4.7n$ F and a minimum  $C_2$  (effective) =  $10\mu$ F.

Note that, for high voltage  $A_{VDD}$ , the voltage coefficient of ceramic capacitors ( $C_2$ ) reduces their effective capacitance greatly; a  $16V$   $10\mu$ F ceramic can drop to around  $3\mu$ F at  $15V$ .

To improve the transient load response of  $A_{VDD}$  in PI mode, a resistor may be added in series with the  $C_{23}$  capacitor. The larger the resistor the lower the overshoot but at the expense of stability of the converter loop - especially at high currents.

With  $L = 10\mu$ H,  $A_{VDD} = 15V$ ,  $C_{23} = 4.7n$ F,  $C_2$  (effective) should have a capacitance of greater than  $10\mu$ F.  $R_{INT}$  ( $R_7$ ) can have values up to  $5k\Omega$  for  $C_2$  (effective) up to  $20\mu$ F and up to  $10K$  for  $C_2$  (effective) up to  $30\mu$ F.

Larger values of  $R_{INT}$  ( $R_7$ ) may be possible if maximum  $A_{VDD}$  load currents less than the current limit are used. To ensure  $A_{VDD}$  stability, the IC should be operated at the maximum desired current and then the transient load response of  $A_{VDD}$  should be used to determine the maximum value of  $R_{INT}$ .

**Cascaded MOSFET Application**

A 20V N-channel MOSFET is integrated in the boost regulator. For the applications where the output voltage is greater than 20V, an external cascaded MOSFET is needed as shown in Figure 22. The voltage rating of the external MOSFET should be greater than  $V_{BOOST}$ .

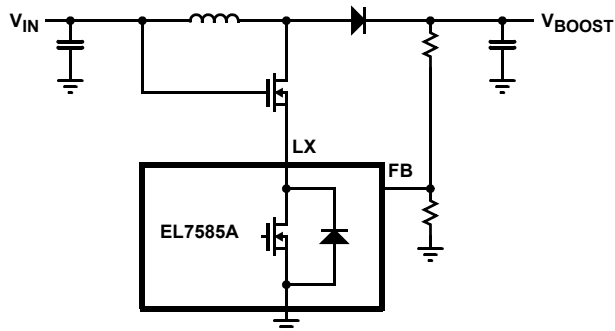

FIGURE 22. CASCADED MOSFET TOPOLOGY FOR HIGH OUTPUT VOLTAGE APPLICATIONS

**Linear-Regulator Controllers ( $V_{ON}$ ,  $V_{LOGIC}$ , and  $V_{OFF}$ )**

The EL7585A includes three independent linear-regulator controllers, in which two are positive output voltage ( $V_{ON}$  and  $V_{LOGIC}$ ), and one is negative. The  $V_{ON}$ ,  $V_{OFF}$ , and  $V_{LOGIC}$  linear-regulator controller functional diagrams, applications circuits are shown in Figures 23, 24, and 25 respectively.

**Calculation of the Linear Regulator Base-Emitter Resistors ( $R_{BL}$ ,  $R_{BP}$  and  $R_{BN}$ )**

For the pass transistor of the linear regulator, low frequency gain ( $H_{fe}$ ) and unity gain freq. ( $f_T$ ) are usually specified in the datasheet. The pass transistor adds a pole to the loop transfer function at  $f_p = f_T / H_{fe}$ . Therefore, in order to maintain phase margin at low frequency, the best choice for a pass device is often a high frequency low gain switching transistor. Further improvement can be obtained by adding a base-emitter resistor  $R_{BE}$  ( $R_{BP}$ ,  $R_{BL}$ ,  $R_{BN}$  in the Functional Block Diagram), which increase the pole frequency to:  $f_p = f_T * (1 + H_{fe} * r_e / R_{BE}) / H_{fe}$ , where  $r_e = KT / qI_C$ . So choose the lowest value  $R_{BE}$  in the design as long as there is still enough base current ( $I_B$ ) to support the maximum output current ( $I_C$ ).

We will take as an example the  $V_{LOGIC}$  linear regulator. If a Fairchild FMMT549 PNP transistor is used as the external pass transistor, Q5 in the application diagram, then for a maximum  $V_{LOGIC}$  operating requirement of 500mA the data sheet indicates  $H_{fe\_min} = 100$ .

The base-emitter saturation voltage is:  $V_{be\_max} = 1.25V$  (note this is normally a  $V_{be} \sim 0.7V$ , however, for the Q5 transistor an internal Darlington arrangement is used to increase it's current gain, giving a 'base-emitter' voltage of  $2 \times V_{BE}$ ).

(Note that using a high current Darlington PNP transistor for Q5 requires that  $V_{IN} > V_{LOGIC} + 2V$ . Should a lower input voltage be required, then an ordinary high gain PNP transistor should be selected for Q5 so as to allow a lower collector-emitter saturation voltage).

For the EL7585A, the minimum drive current is:  $I_{DRVL\_min} = 8mA$

The minimum base-emitter resistor,  $R_{BL}$ , can now be calculated as:

$$R_{BL\_min} = V_{BE\_max} / (I_{DRVL\_min} - I_C / H_{fe\_min}) = 1.25V / (8mA - 500mA / 100) = 417\Omega$$

This is the minimum value that can be used - so, we now choose a convenient value greater than this minimum value; say 500 $\Omega$ . Larger values may be used to reduce quiescent current, however, regulation may be adversely affected, by supply noise if  $R_{BL}$  is made too high in value.

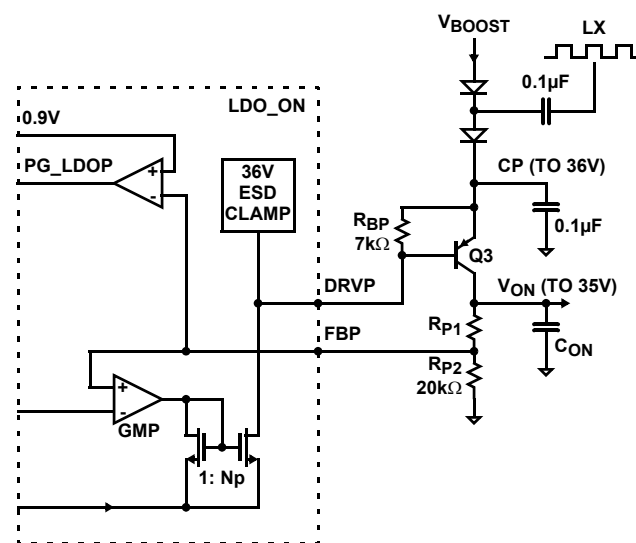

FIGURE 23.  $V_{ON}$  FUNCTIONAL BLOCK DIAGRAM

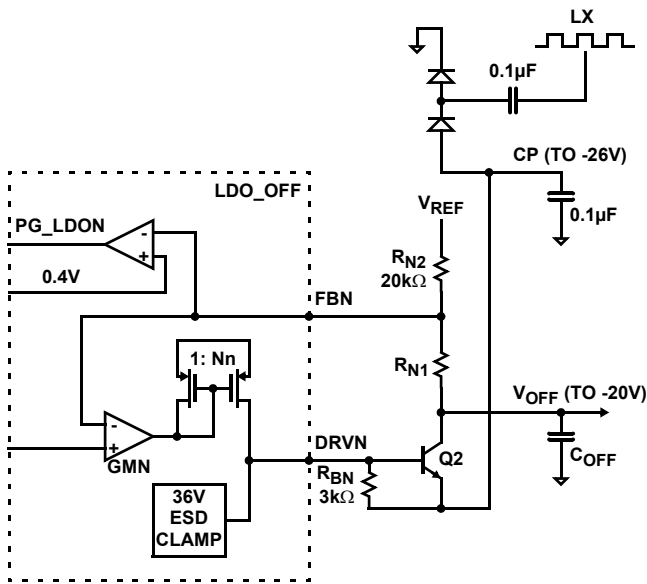

FIGURE 24. V<sub>OFF</sub> FUNCTIONAL BLOCK DIAGRAM

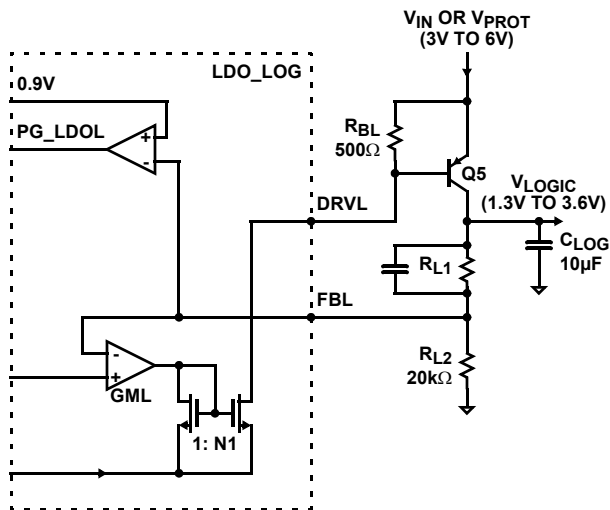

FIGURE 25. V<sub>LOGIC</sub> FUNCTIONAL BLOCK DIAGRAM

The V<sub>ON</sub> power supply is used to power the positive supply of the row driver in the LCD panel. The DC-DC consists of an external diode-capacitor charge pump powered from the inductor (LX) of the boost converter, followed by a low dropout linear regulator (LDO\_ON). The LDO\_ON regulator uses an external PNP transistor as the pass element. The onboard LDO controller is a wide band (>10MHz) transconductance amplifier capable of 4mA drive current, which is sufficient for up to 40mA or more output current under the low dropout condition (forced beta of 10). Typical V<sub>ON</sub> voltage supported by EL7585A ranges from +15V to +36V. A fault comparator is also included for monitoring the output voltage. The under-voltage threshold is set at 25% below the 1.2V reference.

The V<sub>OFF</sub> power supply is used to power the negative supply of the row driver in the LCD panel. The DC-DC

consists of an external diode-capacitor charge pump powered from the inductor (LX) of the boost converter, followed by a low dropout linear regulator (LDO\_OFF). The LDO\_OFF regulator uses an external NPN transistor as the pass element. The onboard LDO controller is a wide band (>10MHz) transconductance amplifier capable of 4mA drive current, which is sufficient for up to 40mA or more output current under the low dropout condition (forced beta of 10). Typical V<sub>OFF</sub> voltage supported by EL7585A ranges from -5V to -20V. A fault comparator is also included for monitoring the output voltage. The undervoltage threshold is set at 200mV above the 0.2V reference level.

The V<sub>LOGIC</sub> power supply is used to power the logic circuitry within the LCD panel. The DC-DC may be powered directly from the low voltage input, 3.3V or 5.0V, or it may be powered through the fault protection switch. The LDO\_LOGIC regulator uses an external PNP transistor as the pass element. The onboard LDO controller is a wide band (>10MHz) transconductance amplifier capable of 16mA drive current, which is sufficient for up to 160mA or more output current under the low dropout condition (forced beta of 10). Typical V<sub>LOGIC</sub> voltage supported by EL7585A ranges from +1.3V to V<sub>DD</sub>-0.2V. A fault comparator is also included for monitoring the output voltage. The undervoltage threshold is set at 25% below the 1.2V reference.

### Set-Up Output Voltage

Refer to the Typical Application Diagram, the output voltages of V<sub>ON</sub>, V<sub>OFF</sub>, and V<sub>LOGIC</sub> are determined by the following equations:

$$V_{ON} = V_{REF} \times \left( 1 + \frac{R_{12}}{R_{11}} \right)$$

$$V_{OFF} = V_{REFN} + \frac{R_{22}}{R_{21}} \times (V_{REFN} - V_{REF})$$

$$V_{LOGIC} = V_{REF} \times \left( 1 + \frac{R_{42}}{R_{41}} \right)$$

Where V<sub>REF</sub> = 1.2V, V<sub>REFN</sub> = 0.2V.

Resistor networks in the order of 250kΩ, 120kΩ and 10kΩ are recommended for V<sub>ON</sub>, V<sub>OFF</sub> and V<sub>LOGIC</sub>, respectively.

### Charge Pump

To generate an output voltage higher than V<sub>BOOST</sub>, single or multiple stages of charge pumps are needed. The number of stage is determined by the input and output voltage. For positive charge pump stages:

$$N_{POSITIVE} \geq \frac{V_{OUT} + V_{CE} - V_{INPUT}}{V_{INPUT} - 2 \times V_F}$$

where V<sub>CE</sub> is the dropout voltage of the pass component of the linear regulator. It ranges from 0.3V to 1V depending on

## EL7585A

the transistor.  $V_F$  is the forward-voltage of the charge pump rectifier diode.

The number of negative charge pump stages is given by:

$$N_{\text{NEGATIVE}} \geq \frac{|V_{\text{OUTPUT}}| + V_{CE}}{V_{\text{INPUT}} - 2 \times V_F}$$

To achieve high efficiency and low material cost, the lowest number of charge pump stages which can meet the above requirements, is always preferred.

### High Charge Pump Output Voltage (>36V) Applications

In the applications where the charge pump output voltage is over 36V, an external npn transistor need to be inserted into between DRVP pin and base of pass transistor Q3 as shown in Figure 26; or the linear regulator can control only one stage charge pump and regulate the final charge pump output as shown in Figure 27.

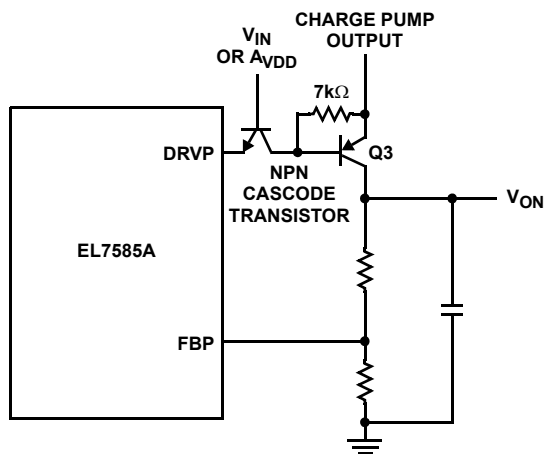

FIGURE 26. CASCODE NPN TRANSISTOR CONFIGURATION FOR HIGH CHARGE PUMP OUTPUT VOLTAGE (>36V)

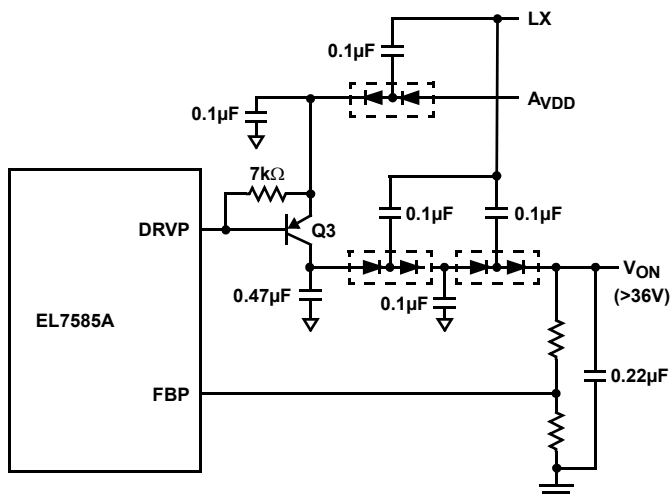

FIGURE 27. THE LINEAR REGULATOR CONTROLS ONE STAGE OF CHARGE PUMP

### Discontinuous/Continuous Boost Operation and its Effect on the Charge Pumps

The EL7585A  $V_{ON}$  and  $V_{OFF}$  architecture uses LX switching edges to drive diode charge pumps from which LDO regulators generate the  $V_{ON}$  and  $V_{OFF}$  supplies. It can be appreciated that should a regular supply of LX switching edges be interrupted, for example during discontinuous operation at light  $A_{VDD}$  boost load currents, then this may affect the performance of  $V_{ON}$  and  $V_{OFF}$  regulation - depending on their exact loading conditions at the time.

To optimize  $V_{ON}/V_{OFF}$  regulation, the boundary of discontinuous/continuous operation of the boost converter can be adjusted, by suitable choice of inductor given  $V_{IN}$ ,  $V_{OUT}$ , switching frequency and the  $A_{VDD}$  current loading, to be in continuous operation.

The following equation gives the boundary between discontinuous and continuous boost operation. For continuous operation (LX switching every clock cycle) we require that:

$$I(A_{VDD\_load}) > D \cdot (1-D) \cdot V_{IN} / (2 \cdot L \cdot F_{OSC})$$

where the duty cycle,  $D = (A_{VDD} - V_{IN}) / A_{VDD}$

For example, with  $V_{IN} = 5V$ ,  $F_{OSC} = 1.0MHz$  and  $A_{VDD} = 12V$  we find continuous operation of the boost converter can be guaranteed for:

$$L = 10\mu H \text{ and } I(A_{VDD}) > 61mA$$

$$L = 6.8\mu H \text{ and } I(A_{VDD}) > 89mA$$

$$L = 3.3\mu H \text{ and } I(A_{VDD}) > 184mA$$

### Charge Pump Output Capacitors

Ceramic capacitors with low ESR are recommended. With ceramic capacitors, the output ripple voltage is dominated by the capacitance value. The capacitance value can be chosen by the following equation:

$$C_{OUT} \geq \frac{I_{OUT}}{2 \times V_{RIPPLE} \times f_{OSC}}$$

where  $f_{OSC}$  is the switching frequency.

### Start-Up Sequence

Figure 28 shows a detailed start-up sequence waveform. For a successful power-up, there should be six peaks at  $V_{CDLY}$ . When a fault is detected, the device will latch off until either EN is toggled or the input supply is recycled.

When the input voltage ( $V_{DD}$ ) exceeds 2.5V,  $V_{REF}$  and  $V_{LOGIC}$  turn on. At the same time, if EN is tied to  $V_{DD}$ , an internal current source starts to charge  $C_{DLY}$  to an upper threshold using a fast ramp followed by a slow ramp. If EN is low at this point, the  $C_{DLY}$  ramp will be delayed until EN goes high.

The first four ramps on  $C_{DLY}$  (two up, two down) are used to initialize the fault protection switch and to check whether

## EL7585A

there is a fault condition on  $C_{DLY}$  or  $V_{REF}$ . If a fault is detected, the outputs and the input protection will turn off, but  $V_{REF}$  will stay on. If no fault is found,  $C_{DLY}$  continues ramping up and down.

During the second ramp, the device checks the status of  $V_{REF}$  and over temperature. At the peak of the second ramp, PG output goes low and enables the input protection PMOS Q1. Q1 is a controlled FET used to prevent in-rush current into  $V_{BOOST}$  before  $V_{BOOST}$  is enabled internally. Its rate of turn on is controlled by  $C_O$ . When a fault is detected, M1 will turn off and disconnect the inductor from  $V_{IN}$ .

With the input protection FET on, NODE1 (See Typical Application Diagram) will rise to  $\sim V_{IN}$ . Initially the boost is not enabled so  $V_{BOOST}$  rises to  $V_{IN}-V_{DIODE}$  through the output diode. Hence, there is a step at  $V_{BOOST}$  during this part of the start-up sequence. If this step is not desirable, an external PMOS FET can be used to delay the output until the boost is enabled internally. The delayed output appears at  $A_{VDD}$ .

For EL7585A,  $V_{BOOST}$  soft-start at the beginning of the third ramp. The soft-start ramp depends on the value of the  $C_{DLY}$  capacitor. For  $C_{DLY}$  of 220nF, the soft-start time is  $\sim 2$ ms.

$V_{OFF}$  turns on at the start of the fourth peak. At the fifth peak, DELB gate goes low to turn on the external PMOS Q4 to generate a delayed  $V_{BOOST}$  output.

$V_{ON}$  is enabled at the beginning of the sixth ramp.  $A_{VDD}$ , PG,  $V_{OFF}$ , DELB and  $V_{ON}$  are checked at end of this ramp.

### Fault Protection

During the startup sequence, prior to BOOST soft-start,  $V_{REF}$  is checked to be within  $\pm 20\%$  of its final value and the device temperature is checked. If either of these are not within the expected range, the part is disabled until the power is recycled or EN is toggled.

If  $C_{DELAY}$  is shorted low, then the sequence will not start, while if  $C_{DELAY}$  is shorted H, the first down ramp will not occur and the sequence will not complete.

Once the start-up sequence is completed, the chip continuously monitors  $C_{DLY}$ , DELB, FBP, FBL, FBN,  $V_{REF}$ , FBB and PG and checks for faults. During this time, the voltage on the  $C_{DLY}$  capacitor remains at 1.15V until either a fault is detected, or the EN pin is pulled low.

A fault on  $C_{DELAY}$ ,  $V_{REF}$  or temperature will shut down the chip immediately. If a fault on any other output is detected,  $C_{DELAY}$  will ramp up linearly with a 5 $\mu$ A (typical) current to the upper fault threshold (typically 2.4V), at which point the chip is disabled until the power is recycled or EN is toggled. If the fault condition is removed prior to the end of the ramp, the voltage on the  $C_{DLY}$  capacitor returns to 1.15V.

Typical fault thresholds for FBP, FBL, FBN and FBB are included in the tables. PG and DELB fault thresholds are typically 0.6V.

$C_{INT}$  has an internal current-limited clamp to keep the voltage within its normal range. If  $C_{INT}$  is shorted low, the boost regulator will attempt to regulate to 0V. If  $C_{INT}$  is shorted H, the regulator switches to P mode.

If any of the regulated outputs ( $V_{BOOST}$ ,  $V_{ON}$ ,  $V_{OFF}$  or  $V_{LOGIC}$ ) are driven above their target levels the drive circuitry will switch off until the output returns to its expected value.

If  $V_{BOOST}$  is excessively loaded, the current limit will prevent damage to the chip. While in current limit, the part acts like a current source and the regulated output will drop. If the output drops below the fault threshold, a ramp will be initiated on  $C_{DELAY}$  and, provided that the fault is sustained, the chip will be disabled on completion of the ramp.

In some circumstances, (depending on ambient temperature and thermal design of the board), continuous operation at current limit may result in the over-temperature threshold being exceeded, which will cause the part to disable immediately.

All I/O also have ESD protection, which in many cases will also provide overvoltage protection, relative to either ground or  $V_{DD}$ . However, these will not generally operate unless abs max ratings are exceeded.

### Component Selection for Start-Up Sequencing and Fault Protection

The  $C_{REF}$  capacitor is typically set at 220nF and is required to stabilize the  $V_{REF}$  output. The range of  $C_{REF}$  is from 22nF to 1 $\mu$ F and should not be more than five times the capacitor on  $C_{DEL}$  to ensure correct start-up operation.

The  $C_{DEL}$  capacitor is typically 220nF and has a usable range from 47nF minimum to several microfarads - only limited by the leakage in the capacitor reaching  $\mu$ A levels.

$C_{DEL}$  should be at least 1/5 of the value of  $C_{REF}$  (See above). Note with 220nF on  $C_{DEL}$  the fault time-out will be typically 50ms and the use of a larger/smaller value will vary this time proportionally (e.g. 1 $\mu$ F will give a fault time-out period of typically 230ms).

### Fault Sequencing

The EL7585A has an advanced fault detection system which protects the IC from both adjacent pin shorts during operation and shorts on the output supplies.

A high quality layout/design of the PCB, in respect of grounding quality and decoupling is necessary to avoid falsely triggering the fault detection scheme - especially during start-up. The user is directed to the layout guidelines and component selection sections to avoid problems during initial evaluation and prototype PCB generation.

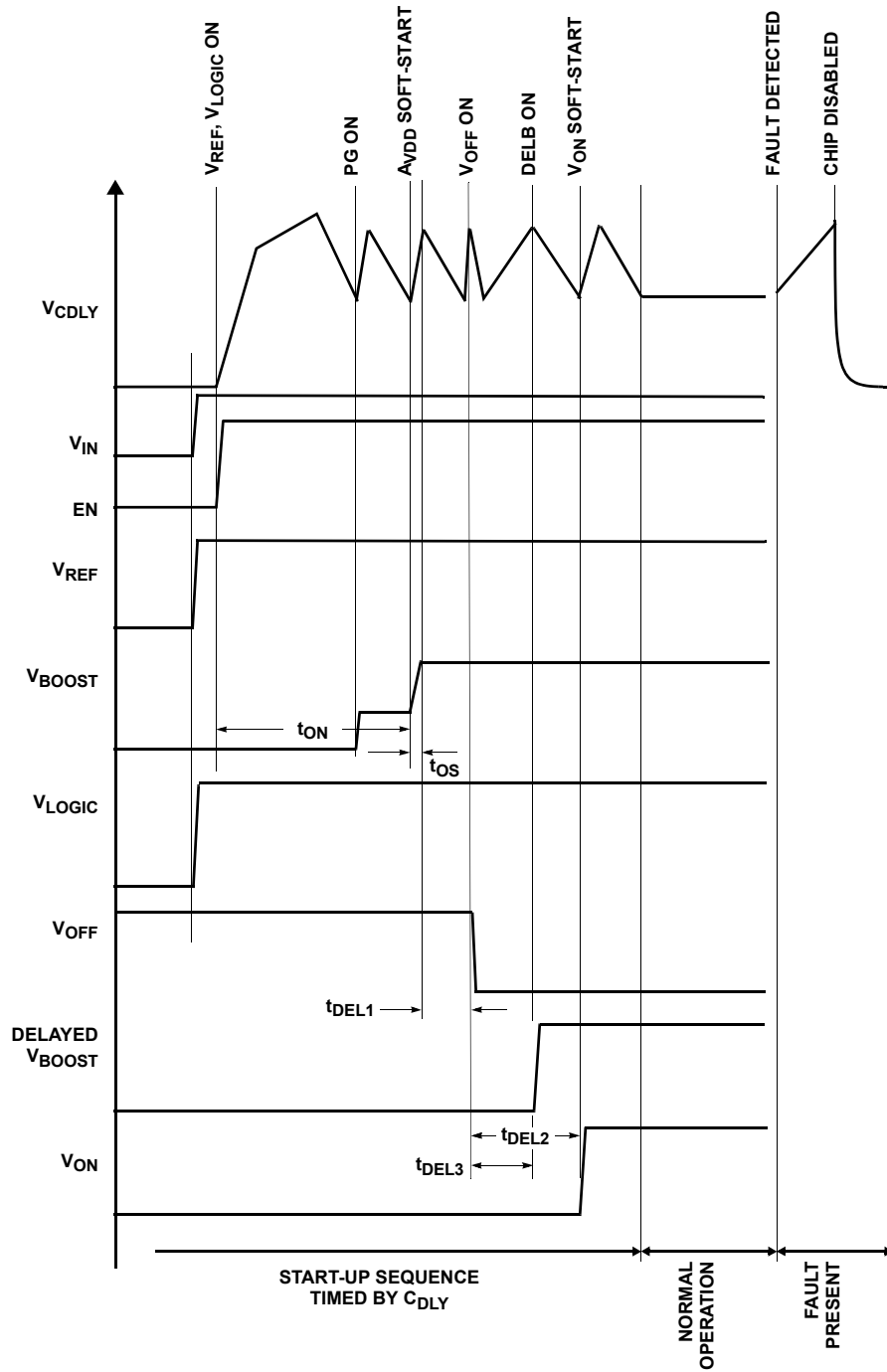

FIGURE 28. START-UP SEQUENCE

### Over-Temperature Protection

An internal temperature sensor continuously monitors the die temperature. In the event that the die temperature exceeds the thermal trip point of 140°C, the device will shut down.

### Layout Recommendation

The device's performance including efficiency, output noise, transient response and control loop stability is dramatically affected by the PCB layout. PCB layout is critical, especially at high switching frequency.

There are some general guidelines for layout:

1. Place the external power components (the input capacitors, output capacitors, boost inductor and output diodes, etc.) in close proximity to the device. Traces to these components should be kept as short and wide as possible to minimize parasitic inductance and resistance.
2. Place  $V_{REF}$  and  $V_{DD}$  bypass capacitors close to the pins.
3. Minimize the length of traces carrying fast signals and high current.
4. All feedback networks should sense the output voltage directly from the point of load, and be as far away from LX node as possible.
5. The power ground (PGND) and signal ground (SGND) pins should be connected at only one point near the main decoupling capacitors.

6. The exposed die plate, on the underneath of the package, should be soldered to an equivalent area of metal on the PCB. This contact area should have multiple via connections to the back of the PCB as well as connections to intermediate PCB layers, if available, to maximize thermal dissipation away from the IC.
7. To minimize the thermal resistance of the package when soldered to a multi-layer PCB, the amount of copper track and ground plane area connected to the exposed die plate should be maximized and spread out as far as possible from the IC. The bottom and top PCB areas especially should be maximized to allow thermal dissipation to the surrounding air.
8. A signal ground plane, separate from the power ground plane and connected to the power ground pins only at the exposed die plate, should be used for ground return connections for feedback resistor networks ( $R_1$ ,  $R_{11}$ ,  $R_{41}$ ) and the  $V_{REF}$  capacitor,  $C_{22}$ , the  $C_{DELAY}$  capacitor  $C_7$  and the integrator capacitor  $C_{23}$ .
9. Minimize feedback input track lengths to avoid switching noise pick-up.

A two-layer demo board is available to illustrate the proper layout implementation. A four-layer demo board can be used to further optimize the layout recommendations.

### Demo Board Layout

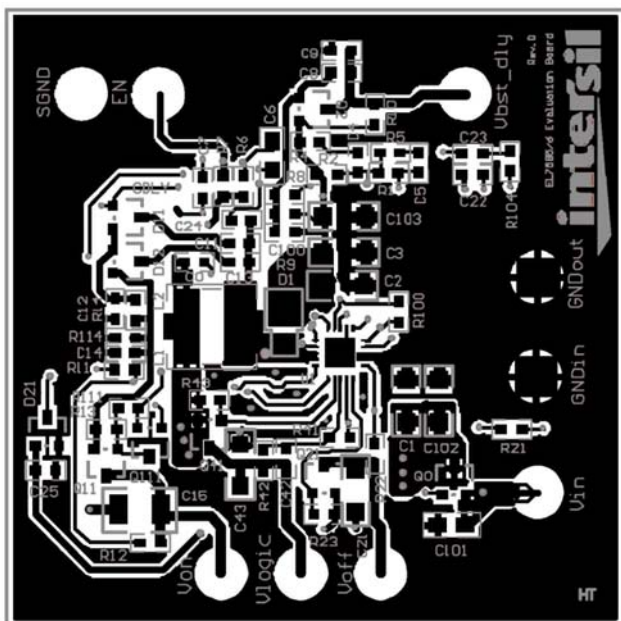

FIGURE 29. TOP LAYER

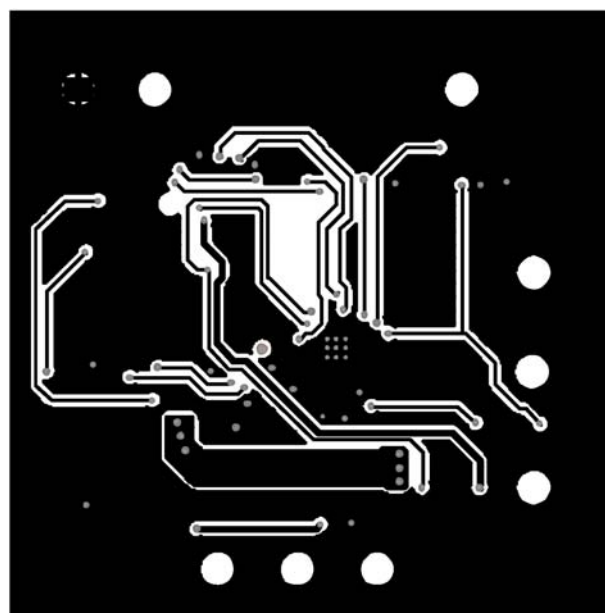
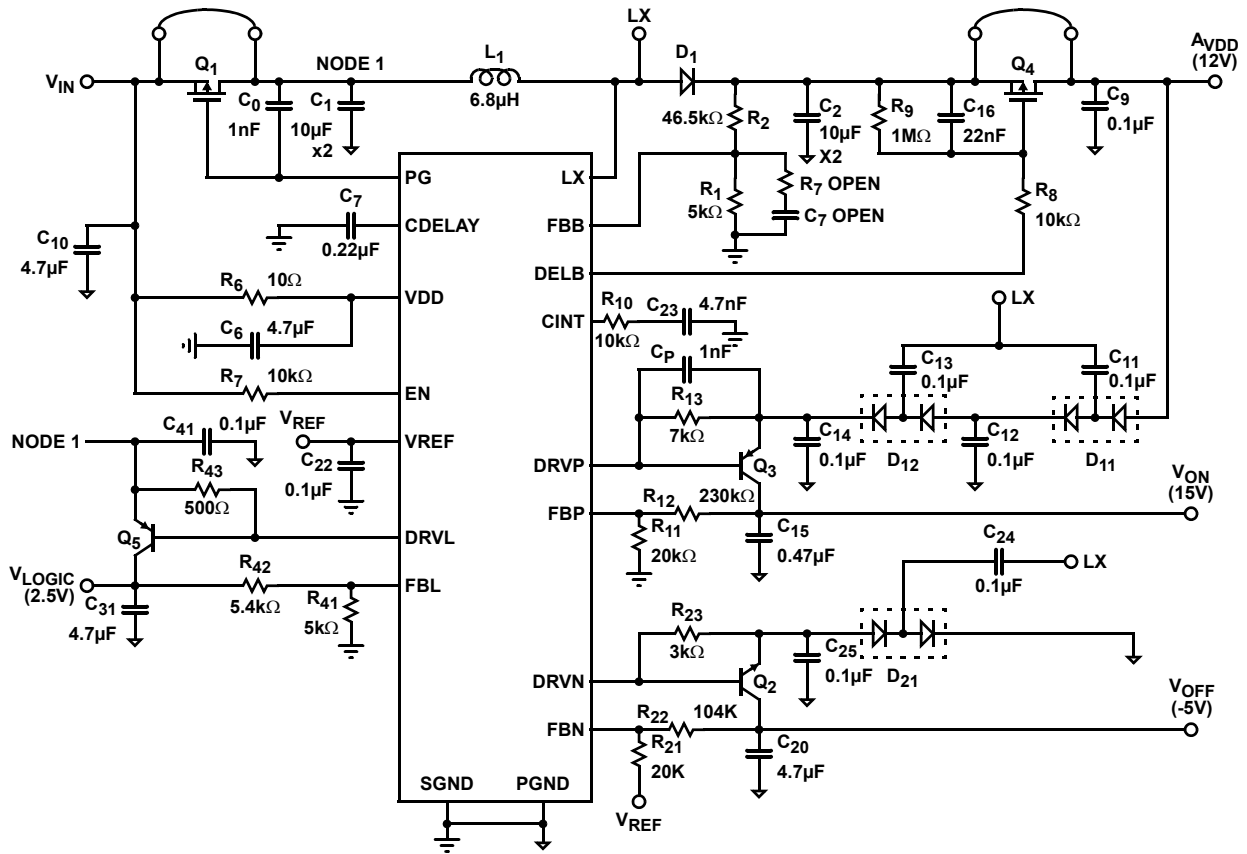

FIGURE 30. BOTTOM LAYER



# EL7585A

## Typical Application Diagram



NOTE: The SGND should be connected to the exposed die plate and connected to the PGND at one point only.

# EL7585A

## QFN Package Outline Drawing

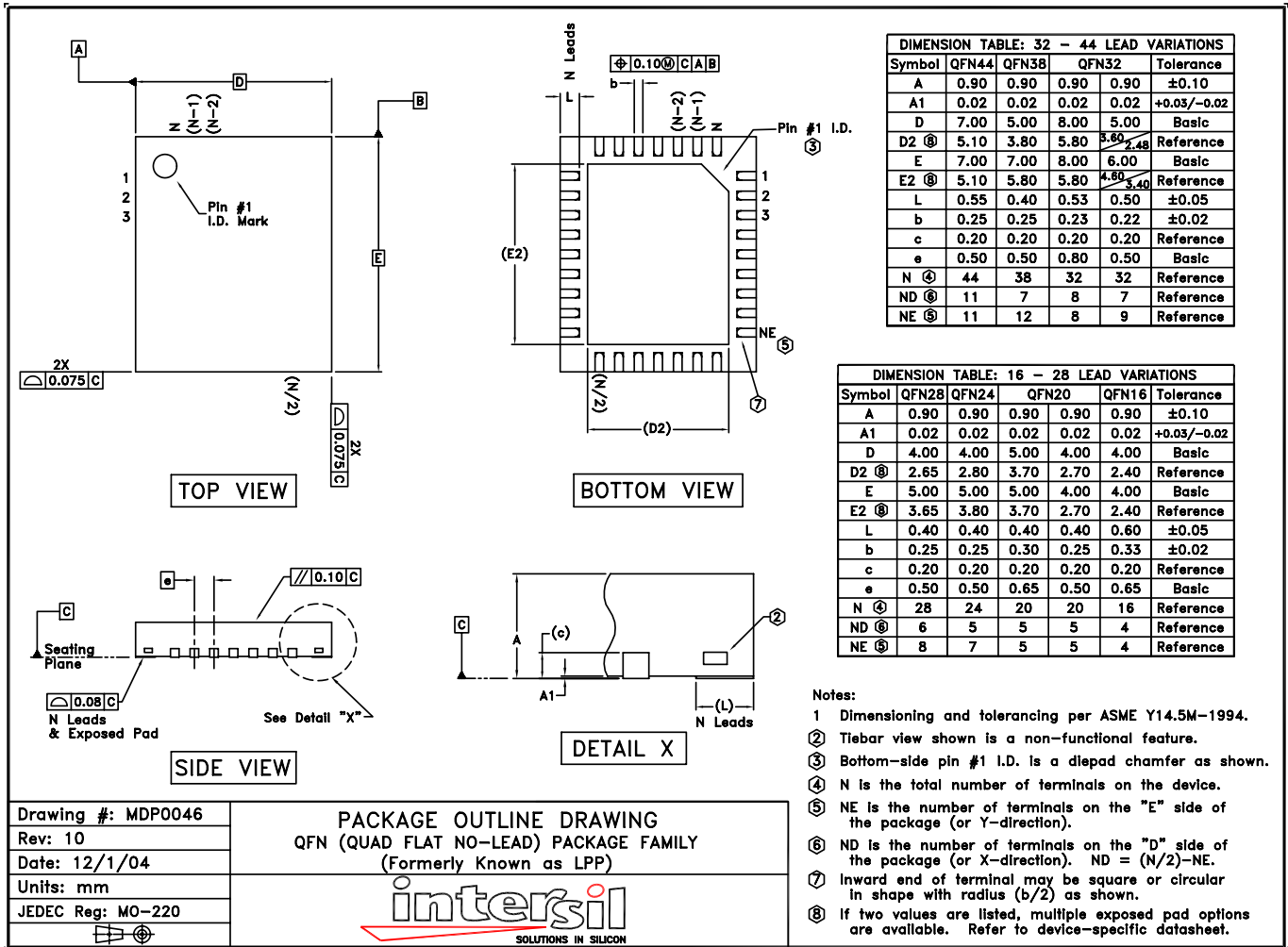

NOTE: The package drawing shown here may not be the latest version. To check the latest revision, please refer to the Intersil website at <http://www.intersil.com/design/packages/index.asp>

All Intersil U.S. products are manufactured, assembled and tested utilizing ISO9000 quality systems. Intersil Corporation's quality certifications can be viewed at [www.intersil.com/design/quality](http://www.intersil.com/design/quality)

Intersil products are sold by description only. Intersil Corporation reserves the right to make changes in circuit design, software and/or specifications at any time without notice. Accordingly, the reader is cautioned to verify that data sheets are current before placing orders. Information furnished by Intersil is believed to be accurate and reliable. However, no responsibility is assumed by Intersil or its subsidiaries for its use; nor for any infringements of patents or other rights of third parties which may result from its use. No license is granted by implication or otherwise under any patent or patent rights of Intersil or its subsidiaries.

For information regarding Intersil Corporation and its products, see [www.intersil.com](http://www.intersil.com)