

# MAXIM

## Fault-Protected, High-Voltage, Single 4-to-1/Dual 2-to-1 Multiplexers

### General Description

The MAX4534 (single 4-to-1) and MAX4535 (dual 2-to-1) fault-protected multiplexers operate with  $\pm 4.5\text{V}$  to  $\pm 20\text{V}$  dual supplies or a  $+9\text{V}$  to  $+36\text{V}$  single supply. These multiplexers feature fault-protected inputs, Rail-to-Rail® signal-handling capability, and overvoltage clamping at  $150\text{mV}$  beyond the rails. Both parts feature  $\pm 40\text{V}$  overvoltage protection with supplies off and  $\pm 25\text{V}$  protection with supplies on. On-resistance is  $400\Omega$  max and is matched between channels to  $10\Omega$  max. All digital inputs have TTL logic thresholds, ensuring TTL/CMOS-logic compatibility when using a single  $+12\text{V}$  or dual  $\pm 15\text{V}$  supplies.

### Applications

- Data-Acquisition Systems
- Industrial and Process Control
- Avionics
- Signal Routing
- Redundant/Backup Systems

### Features

- ◆  $\pm 40\text{V}$  Fault Protection with Power Off
- ◆  $\pm 25\text{V}$  Fault Protection with  $\pm 15\text{V}$  Supplies
- ◆ No Power-Supply Sequencing Required
- ◆ All Channels Off with Power Off
- ◆ Rail-to-Rail Signal Handling
- ◆ Output Clamped to Appropriate Supply Voltage During Fault Condition
- ◆  $1.0\text{k}\Omega$  typ Output Clamp Resistance During Overvoltage
- ◆  $400\Omega$  max On-Resistance
- ◆  $20\text{ns}$  typ Fault Response Time
- ◆  $\pm 4.5\text{V}$  to  $\pm 20\text{V}$  Dual Supplies
- ◆  $+9\text{V}$  to  $+36\text{V}$  Single Supply
- ◆ TTL/CMOS-Compatible Logic Inputs

MAX4534/MAX4535

### Pin Configurations

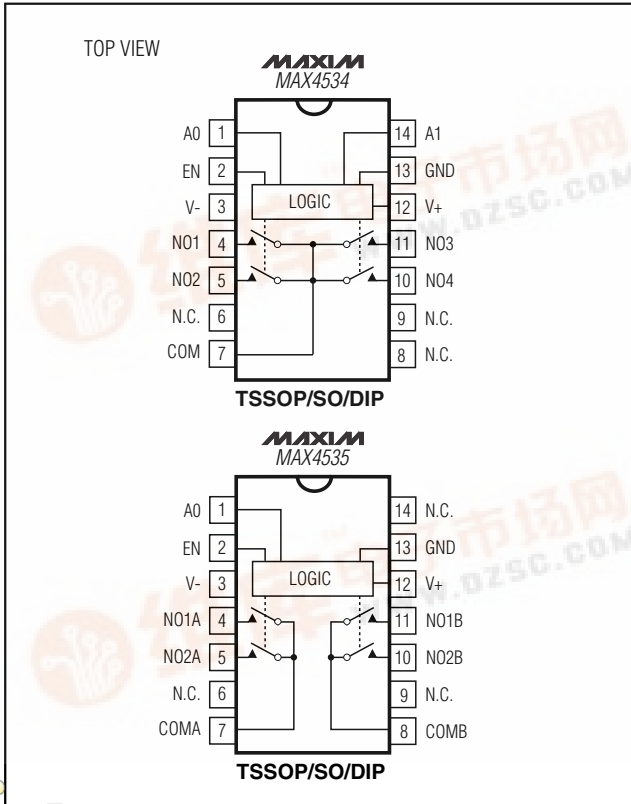

### Ordering Information

PART	TEMP. RANGE	PIN-PACKAGE
MAX4534CUD	$0^{\circ}\text{C}$ to $+70^{\circ}\text{C}$	14 TSSOP
MAX4534CSD	$0^{\circ}\text{C}$ to $+70^{\circ}\text{C}$	14 Narrow SO
MAX4534CPD	$0^{\circ}\text{C}$ to $+70^{\circ}\text{C}$	14 Plastic DIP
MAX4534EUD	$-40^{\circ}\text{C}$ to $+85^{\circ}\text{C}$	14 TSSOP
MAX4534ESD	$-40^{\circ}\text{C}$ to $+85^{\circ}\text{C}$	14 Narrow SO
MAX4534EPD	$-40^{\circ}\text{C}$ to $+85^{\circ}\text{C}$	14 Plastic DIP
MAX4535CUD	$0^{\circ}\text{C}$ to $+70^{\circ}\text{C}$	14 TSSOP
MAX4535CSD	$0^{\circ}\text{C}$ to $+70^{\circ}\text{C}$	14 Narrow SO
MAX4535CPD	$0^{\circ}\text{C}$ to $+70^{\circ}\text{C}$	14 Plastic SO
MAX4535EUD	$-40^{\circ}\text{C}$ to $+85^{\circ}\text{C}$	14 TSSOP
MAX4535ESD	$-40^{\circ}\text{C}$ to $+85^{\circ}\text{C}$	14 Narrow SO
MAX4535EPD	$-40^{\circ}\text{C}$ to $+85^{\circ}\text{C}$	14 Plastic DIP

Rail-to-Rail is a registered trademark of Nippon Motorola, Ltd.

# Fault-Protected, High-Voltage, Single 4-to-1/Dual 2-to-1 Multiplexers

## ABSOLUTE MAXIMUM RATINGS

(Voltages Referenced to GND)

V+	-0.3V to +44V
V-	-44V to +0.3V
V+ to V-	-0.3V to +44V
COM_, A_, EN (Note 1)	(V- - 0.3V) to (V+ + 0.3V)
NO_ (Note 2)	(V+ - 40V) to (V- + 40V)
NO_ to COM_ (Note 2)	-40V to +40V
NO_ Overvoltage with Switch Power On (Note 2)	-36V to +36V
NO_ Overvoltage with Switch Power Off (Note 2)	-40V to +40V
Continuous Current into Any Terminal	±30mA
Peak Current Into Any Terminal (pulsed at 1ms, 10% duty cycle)	±100mA

Continuous Power Dissipation (T<sub>A</sub> = +70°C)

14-Pin TSSOP (derate 6.3mW/°C above +70°C)	500mW
14-Pin Narrow SO (derate 8mW/°C above +70°C)	640mW
14-Pin Plastic DIP (derate 10mW/°C above +70°C)	800mW
Operating Temperature Ranges	
MAX453_C_D	0°C to +70°C
MAX453_E_D	-40°C to +85°C
Storage Temperature Range	-65°C to +150°C
Lead Temperature (soldering, 10s)	+300°C

**Note 1:** COM\_, EN, and A\_ pins are not fault protected. Signals on COM\_, EN, or A\_ exceeding V+ or V- are clamped by internal diodes. Limit forward diode current to maximum current rating.

**Note 2:** NO\_ pins are fault-protected. Signals on NO\_ exceeding -25V to +25V may damage the device during power-on conditions. When the power is off the maximum voltage range is -40V to +40V.

Stresses beyond those listed under "Absolute Maximum Ratings" may cause permanent damage to the device. These are stress ratings only, and functional operation of the device at these or any other conditions beyond those indicated in the operational sections of the specifications is not implied. Exposure to absolute maximum rating conditions for extended periods may affect device reliability.

## ELECTRICAL CHARACTERISTICS—Dual Supplies

(V+ = +15V, V- = -15V, V<sub>AH</sub> = V<sub>ENH</sub> = 2.4V, V<sub>AL</sub> = V<sub>ENL</sub> = 0.8V, T<sub>A</sub> = T<sub>MIN</sub> to T<sub>MAX</sub>, unless otherwise noted. Typical values are at T<sub>A</sub> = +25°C.) (Note 3)

PARAMETER	SYMBOL	CONDITIONS	T <sub>A</sub>	MIN	TYP	MAX	UNITS	
<b>ANALOG SWITCH</b>								
Fault-Free Analog Signal Range	V <sub>NO_</sub>	Applies with power on or off		V-		V+	V	
On-Resistance	R <sub>ON</sub>	V <sub>COM_</sub> = ±10V, I <sub>NO_</sub> = 1mA	+25°C		275	400	Ω	
			C, E			500		
On-Resistance Match Between Channels (Note 4)	ΔR <sub>ON</sub>	V <sub>COM_</sub> = ±10V, I <sub>NO_</sub> = 1mA	+25°C		2	10	Ω	
			C, E			15		
NO_ Off-Leakage Current (Note 5)	I <sub>NO_(OFF)</sub>	V <sub>NO_</sub> = ±10V, V <sub>COM_</sub> = ∓10V	+25°C	-0.5	0.01	0.5	nA	
			C, E	-5		5		
COM_ Off-Leakage Current (Note 5)	I <sub>COM_(OFF)</sub>	V <sub>COM_</sub> = ±10V, V <sub>NO_</sub> = ∓10V	+25°C	-2	0.05	2	nA	
			C, E	-20		20		
			MAX4535	+25°C	-1	0.05		1
			C, E	-10		10		
COM_ On-Leakage Current (Note 5)	I <sub>COM_(ON)</sub>	V <sub>COM_</sub> = ±10V, V <sub>NO_</sub> = floating	MAX4534	+25°C	-2	0.1	2	nA
			C, E	-25		25		
			MAX4535	+25°C	-1	0.1	1	
			C, E	-15		15		
<b>FAULT PROTECTION</b>								
Fault-Protected Analog Signal Range (Note 6)	V <sub>NO_</sub>	Applies with power on		-25		+25	nA	
		Applies with power off		-40		+40		
COM_ Output Leakage Current, Supplies On	I <sub>COM_</sub>	V <sub>NO_</sub> = ±25V, V <sub>EN</sub> = 0, V <sub>COM_</sub> = 0	+25°C	-20		20	nA	
			C, E	-1		1	μA	

# Fault-Protected, High-Voltage, Single 4-to-1/Dual 2-to-1 Multiplexers

**MAX4534/MAX4535**

## ELECTRICAL CHARACTERISTICS—Dual Supplies (continued)

(V<sub>+</sub> = +15V, V<sub>-</sub> = -15V, V<sub>A\_H</sub> = V<sub>ENH</sub> = 2.4V, V<sub>A\_L</sub> = V<sub>ENL</sub> = 0.8V, T<sub>A</sub> = T<sub>MIN</sub> to T<sub>MAX</sub>, unless otherwise noted. Typical values are at T<sub>A</sub> = +25°C.) (Note 3)

PARAMETER	SYMBOL	CONDITIONS	T <sub>A</sub>	MIN	TYP	MAX	UNITS
NO <sub>-</sub> Input Leakage Current, Supplies On	I <sub>NO-</sub>	V <sub>NO-</sub> = ±25V, V <sub>COM-</sub> = ∓10V, V <sub>EN</sub> = 0	+25°C	-20		20	nA
			C, E	-200		200	
NO <sub>-</sub> Input Leakage Current, Supplies Off	I <sub>NO-</sub>	V <sub>NO-</sub> = ±40V, V <sub>COM-</sub> = 0, V <sub>+</sub> = 0, V <sub>-</sub> = 0	+25°C	-20		20	nA
			C, E	-5		5	μA
COM <sub>-</sub> On Clamp Output Current, Supplies On	I <sub>COM-</sub>	V <sub>NO-</sub> = +25V V <sub>COM-</sub> = 0	+25°C	7	10	13	mA
		V <sub>NO-</sub> = -25V V <sub>COM-</sub> = 0		-13	-11	-7	
COM <sub>-</sub> On Clamp Output Resistance, Supplies On	R <sub>COM-</sub>	V <sub>NO-</sub> = ±25V	+25°C	0.1	1.0	2.5	kΩ
			C, E	0.08		3	
± Fault Response Time		R <sub>L</sub> = 10kΩ, V <sub>NO-</sub> = ±25V			20		ns
± Fault Recovery Time		R <sub>L</sub> = 10kΩ, V <sub>NO-</sub> = ±25V			2.5		μs
Fault Trip Threshold		R <sub>L</sub> = 1kΩ		V <sub>-</sub> - 400	V <sub>+</sub> + 400		mV
<b>LOGIC INPUT</b>							
Input Logic Voltage High	V <sub>A_H</sub> , V <sub>ENH</sub>			2.4			V
Input Logic Voltage Low	V <sub>A_L</sub> , V <sub>ENL</sub>					0.8	V
Input Logic Current	I <sub>A-</sub> , I <sub>EN</sub>	V <sub>A-</sub> = V <sub>EN</sub> = 0.8V or 2.4V		-1		1	μA
<b>SWITCH DYNAMIC CHARACTERISTICS</b>							
Enable Turn-On Time	t <sub>ON</sub>	V <sub>NO-</sub> = ±10V, R <sub>L</sub> = 1kΩ, Figure 3	+25°C		135	275	ns
			C, E			400	
Enable Turn-Off Time	t <sub>OFF</sub>	V <sub>NO-</sub> = ±10V, R <sub>L</sub> = 1kΩ, Figure 3	+25°C		60	200	ns
			C, E			250	
Transition Time	t <sub>TRANS</sub>	Figure 2	+25°C		130	350	ns
			C, E			500	
Break-Before-Make Time Delay	t <sub>BBM</sub>	V <sub>NO-</sub> = ±10V, R <sub>L</sub> = 1kΩ, Figure 4		10	60		ns
Charge Injection (Note 7)	Q	C <sub>L</sub> = 1nF, V <sub>NO-</sub> = 0, R <sub>S</sub> = 0, Figure 5			1	10	pC
Off-Isolation (Note 8)	V <sub>ISO</sub>	R <sub>L</sub> = 50Ω, V <sub>NO-</sub> = 1V <sub>RMS</sub> , f = 1MHz, Figure 6			62		dB
Channel-to-Channel Crosstalk (Note 9)	V <sub>CT</sub>	R <sub>L</sub> = 50Ω, V <sub>NO-</sub> = 1V <sub>RMS</sub> , f = 1MHz, Figure 7			53		dB
NO <sub>-</sub> Off-Capacitance	C <sub>NO-(OFF)</sub>	f = 1MHz, Figure 8			5		pF
COM <sub>-</sub> Off-Capacitance	C <sub>COM-(OFF)</sub>	f = 1MHz, Figure 8	MAX4534		6.5		pF
			MAX4535		4		
COM <sub>-</sub> On-Capacitance	C <sub>COM-(ON)</sub>	f = 1MHz, Figure 8	MAX4534		13.5		pF
			MAX4535		10.5		

## Fault-Protected, High-Voltage, Single 4-to-1/Dual 2-to-1 Multiplexers

### ELECTRICAL CHARACTERISTICS—Dual Supplies (continued)

(V+ = +15V, V- = -15V, V<sub>A\_H</sub> = V<sub>ENH</sub> = 2.4V, V<sub>A\_L</sub> = V<sub>ENL</sub> = 0.8V, T<sub>A</sub> = T<sub>MIN</sub> to T<sub>MAX</sub>, unless otherwise noted. Typical values are at T<sub>A</sub> = +25°C.) (Note 3)

PARAMETER	SYMBOL	CONDITIONS	T <sub>A</sub>	MIN	TYP	MAX	UNITS
<b>POWER SUPPLY</b>							
Power-Supply Range	V+, V-			±4.5		±20	V
V+ Supply Current	I+	All V <sub>A_</sub> = V <sub>EN</sub> = 0 or 5V	+25°C		225	400	μA
			C, E			600	
V- Supply Current	I-	All V <sub>A_</sub> = V <sub>EN</sub> = 0 or 15V	+25°C		125	200	μA
			C, E			300	
GND Supply Current	I <sub>GND</sub>	All V <sub>A_</sub> = V <sub>EN</sub> = 0 or 15V	+25°C		0.01	1	μA
			C, E			10	
		All V <sub>A_</sub> = V <sub>EN</sub> = 5V	+25°C		100	200	
			C, E			300	

### ELECTRICAL CHARACTERISTICS—Single +12V Supply

(V+ = +12V, V- = 0, V<sub>A\_H</sub> = V<sub>ENH</sub> = 2.4V, V<sub>A\_L</sub> = V<sub>ENL</sub> = 0.8V, T<sub>A</sub> = T<sub>MIN</sub> to T<sub>MIN</sub>, unless otherwise noted. Typical values are at T<sub>A</sub> = +25°C.) (Note 3)

PARAMETER	SYMBOL	CONDITIONS	T <sub>A</sub>	MIN	TYP	MAX	UNITS	
<b>ANALOG SWITCH</b>								
Fault-Free Analog Signal Range	V <sub>NO_</sub>	Applies with power on or off		0		V+	V	
On-Resistance	R <sub>ON</sub>	V <sub>COM_</sub> = 10V, I <sub>NO_</sub> = 500μA	+25°C		650	950	Ω	
				C, E		1100		
On-Resistance Match Between Channels (Note 5)	ΔR <sub>ON</sub>	V <sub>COM_</sub> = 10V, I <sub>NO_</sub> = 500μA	+25°C		10	25	Ω	
				C, E		40		
NO_ Off-Leakage Current (Notes 5, 10)	I <sub>NO_(OFF)</sub>	V <sub>COM_</sub> = 10V, 1V; V <sub>NO_</sub> = 1V, 10V	+25°C	-0.5	0.01	0.5	nA	
				C, E		-10		10
COM_ Off-Leakage Current (Notes 5, 10)	I <sub>COM_(OFF)</sub>	V <sub>COM_</sub> = 10V, 1V; V <sub>NO_</sub> = 1V, 10V	MAX4534	+25°C	-2	2	nA	
				C, E		-20		20
			MAX4535	+25°C	-1	1		
				C, E		-15		15
COM_ On-Leakage Current (Notes 5, 10)	I <sub>COM_(ON)</sub>	V <sub>COM_</sub> = 10V, 1V; V <sub>NO_</sub> = 10V, 1V, or floating	MAX4534	+25°C	-2	2	nA	
				C, E		-20		20
			MAX4535	+25°C	-1	1		
				C, E		-15		15

# Fault-Protected, High-Voltage, Single 4-to-1/Dual 2-to-1 Multiplexers

**MAX4534/MAX4535**

## ELECTRICAL CHARACTERISTICS—Single +12V Supply (continued)

(V<sub>+</sub> = +12V, V<sub>-</sub> = 0, V<sub>A\_H</sub> = V<sub>ENH</sub> = 2.4V, V<sub>A\_L</sub> = V<sub>ENL</sub> = 0.8V, T<sub>A</sub> = T<sub>MIN</sub> to T<sub>MIN</sub>, unless otherwise noted. Typical values are at T<sub>A</sub> = +25°C.) (Note 3)

PARAMETER	SYMBOL	CONDITIONS	T <sub>A</sub>	MIN	TYP	MAX	UNITS
<b>FAULT PROTECTION</b>							
Fault-Protected Analog Signal Range (Note 6)	V <sub>NO_</sub>	Applies with all power on	+25°C	-25		25	V
		Applies with all power off		-40		40	
COM_ Output Leakage Current, Supply On	I <sub>COM_</sub>	V <sub>NO_</sub> = ±25V, V <sub>COM_</sub> = 0	+25°C	-20		20	nA
			C, E	-1		1	μA
NO_ Input Leakage Current, Supply On	I <sub>NO_</sub>	V <sub>NO_</sub> = ±25V, V <sub>COM_</sub> = 0,	+25°C	-20		20	nA
			C, E	-5		5	μA
NO_ Input Leakage Current, Supply Off	I <sub>NO_</sub>	V <sub>NO_</sub> = ±40V, V <sub>+</sub> = 0	+25°C	-20	0.1	20	nA
			C, E	-5		5	μA
COM_ ON Output Current, Supply On	I <sub>COM_</sub>	V <sub>NO_</sub> = 25V	+25°C	2	3	5	nA
COM_ ON Output Resistance, Supply On	R <sub>COM_</sub>	V <sub>NO_</sub> = 25V	+25°C		2.4	6	kΩ
Fault Trip Threshold		R <sub>L</sub> = 1kΩ		V <sub>-</sub> - 400	V <sub>+</sub> + 400		mV
<b>LOGIC INPUT</b>							
Input Logic Voltage High	V <sub>A_H</sub> , V <sub>ENH</sub>			2.4			V
Input Logic Voltage Low	V <sub>A_L</sub> , V <sub>ENL</sub>					0.8	V
Input Logic Current	I <sub>A_</sub> , I <sub>EN</sub>	V <sub>A_</sub> = V <sub>EN</sub> = 0.8V or 2.4V		-1		1	μA
<b>SWITCH DYNAMIC CHARACTERISTICS</b>							
Enable Turn-On Time	t <sub>ON</sub>	V <sub>COM_</sub> = 10V, R <sub>L</sub> = 2kΩ, Figure 3	+25°C		220	500	ns
			C, E			700	
Enable Turn-Off Time	t <sub>OFF</sub>	V <sub>COM_</sub> = 10V, R <sub>L</sub> = 2kΩ, Figure 3	+25°C		100	250	ns
			C, E			350	
Break-Before-Make Time Delay	t <sub>BBM</sub>	V <sub>COM_</sub> = 10V, R <sub>L</sub> = 2kΩ, Figure 4	+25°C	50	100		ns
Charge Injection (Note 7)	Q	C <sub>L</sub> = 1nF, V <sub>NO_</sub> = 0, R <sub>S</sub> = 0, Figure 5	+25°C		2	10	pC
Off-Isolation (Note 8)	V <sub>ISO</sub>	R <sub>L</sub> = 50Ω, V <sub>NO_</sub> = 1V <sub>RMS</sub> , f = 1MHz, Figure 6			-62		dB
Channel-to-Channel Crosstalk (Note 9)	V <sub>CT</sub>	R <sub>L</sub> = 50Ω, V <sub>NO_</sub> = 1V <sub>RMS</sub> , f = 1MHz, Figure 7			-65		dB

# Fault-Protected, High-Voltage, Single 4-to-1/Dual 2-to-1 Multiplexers

## ELECTRICAL CHARACTERISTICS—Single +12V Supply (continued)

( $V_+ = +12V$ ,  $V_- = 0$ ,  $V_{A\_H} = V_{ENH} = 2.4V$ ,  $V_{A\_L} = V_{ENL} = 0.8V$ ,  $T_A = T_{MIN}$  to  $T_{MIN}$ , unless otherwise noted. Typical values are at  $T_A = +25^\circ C$ .) (Note 3)

PARAMETER	SYMBOL	CONDITIONS	$T_A$	MIN	TYP	MAX	UNITS
<b>POWER SUPPLY</b>							
Power-Supply Range	$V_+$			9		36	V
V+ Supply Current	$I_+$	All $V_{A\_} = V_{EN} = 0$ or $12V$	$+25^\circ C$		75	150	$\mu A$
			C, E			250	
		All $V_{A\_} = V_{EN} = 5V$	$+25^\circ C$		150	275	
			C, E			375	

- Note 3:** Algebraic convention is used in this data sheet; the most negative value is shown in the minimum column.
- Note 4:**  $\Delta R_{ON} = R_{ON(MAX)} - R_{ON(MIN)}$ .
- Note 5:** Leakage parameters are 100% tested at maximum-rated hot temperature and guaranteed by correlation at  $T_A = 25^\circ C$ .
- Note 6:** NO\_ pins are fault protected, and COM\_ pins are not fault protected. The max input voltage, on NO\_ pins, depends upon the COM\_ load configuration. Generally, the max input voltage is  $\pm 25V$ , with  $\pm 15V$  supplies, and a load referred to ground. For more detailed information, see the *NO\_ Input Voltage section*.
- Note 7:** Guaranteed by design.
- Note 8:** Off-isolation =  $20 \log_{10} (V_{COM\_} / V_{NO\_})$ ,  $V_{COM\_}$  = output,  $V_{NO\_}$  = input to off switch.
- Note 9:** Between any two analog inputs.
- Note 10:** Leakage testing for single-supply operation is guaranteed by testing with dual supplies.

## Typical Operating Characteristics

( $V_+ = +15V$ ,  $V_- = -15V$ ,  $T_A = +25^\circ C$ , unless otherwise noted.)

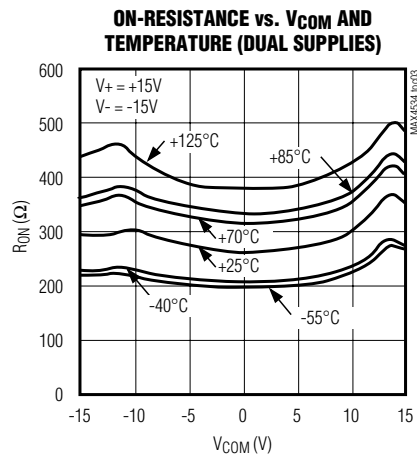
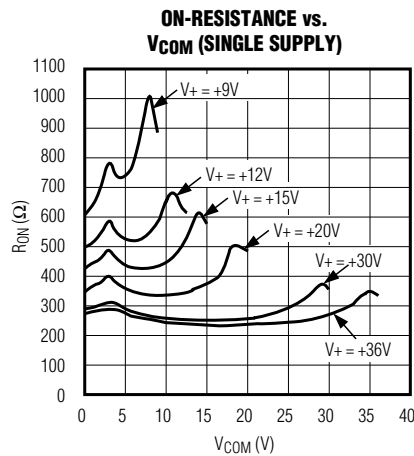
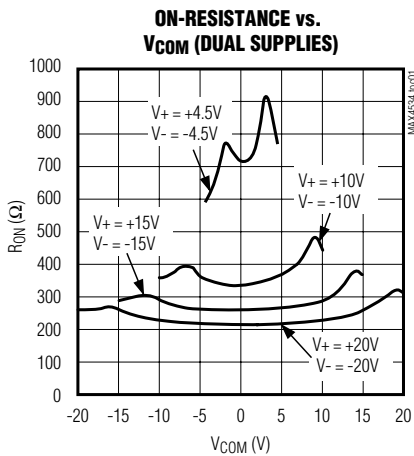

# Fault-Protected, High-Voltage, Single 4-to-1/Dual 2-to-1 Multiplexers

## Typical Operating Characteristics (continued)

( $V_+ = +15V$ ,  $V_- = -15V$ ,  $T_A = +25^\circ C$ , unless otherwise noted.)

MAX4534/MAX4535

**ON-RESISTANCE vs.  $V_{COM}$  AND TEMPERATURE (SINGLE SUPPLY)**

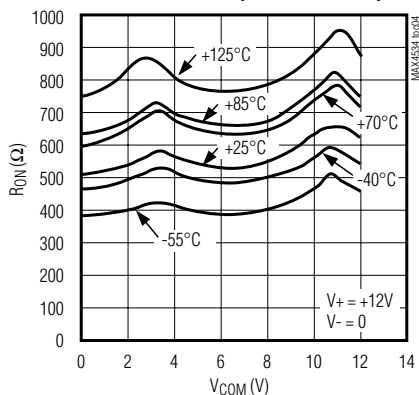

**LEAKAGE CURRENT vs. TEMPERATURE**

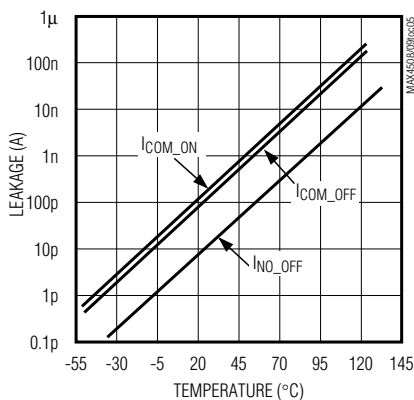

**CHARGE INJECTION vs.  $V_{NO}$  (DUAL AND SINGLE SUPPLIES)**

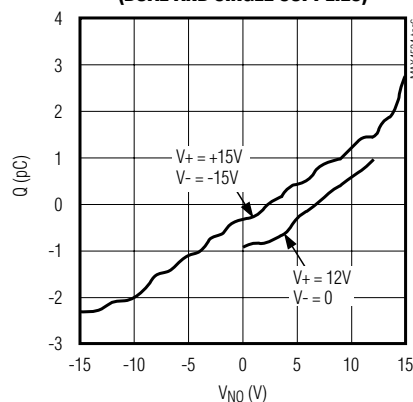

**ENABLE ON/OFF-TIMES vs. SUPPLY VOLTAGE (DUAL SUPPLIES)**

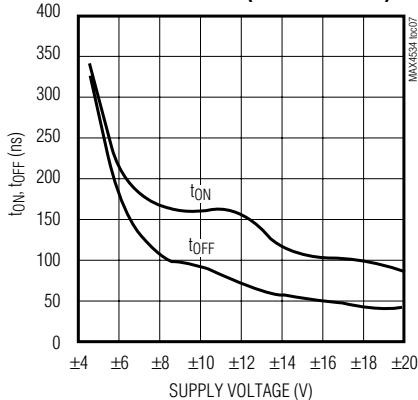

**ENABLE ON/OFF-TIMES vs. SUPPLY VOLTAGE (SINGLE SUPPLY)**

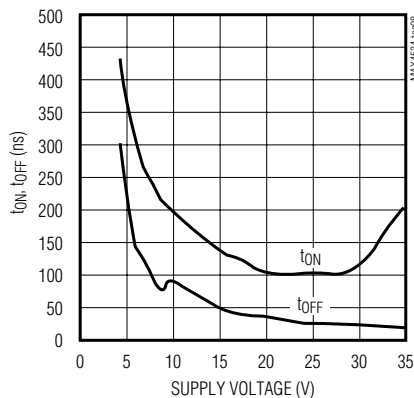

**ENABLE ON/OFF-TIMES vs. TEMPERATURE**

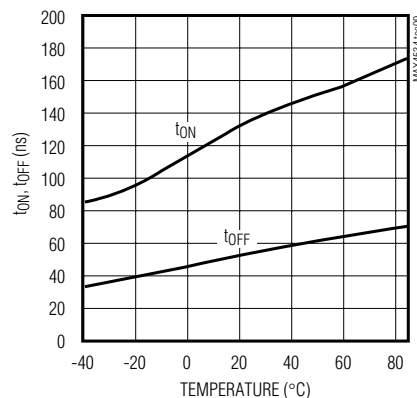

**POWER-SUPPLY CURRENT vs. TEMPERATURE ( $V_{A0} = V_{A1} = V_{EN} = 0$ )**

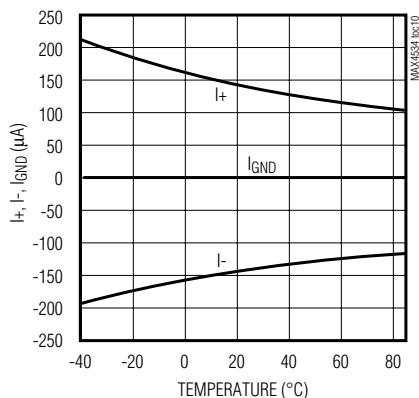

**POWER-SUPPLY CURRENT vs. TEMPERATURE ( $V_{A0} = V_{A1} = V_{EN} = 5V$ )**

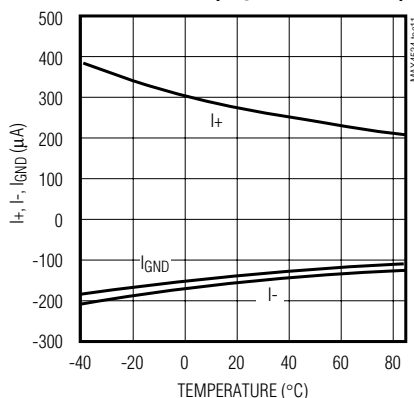

**POWER-SUPPLY CURRENT vs. LOGIC VOLTAGE ( $V_A$ ,  $V_{EN}$ )**

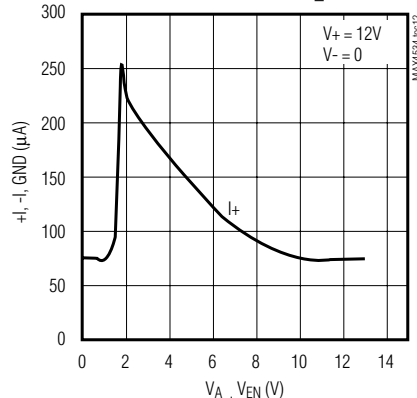

# Fault-Protected, High-Voltage, Single 4-to-1/Dual 2-to-1 Multiplexers

## Typical Operating Characteristics (continued)

( $V_+ = +15V$ ,  $V_- = -15V$ ,  $T_A = +25^\circ C$ , unless otherwise noted.)

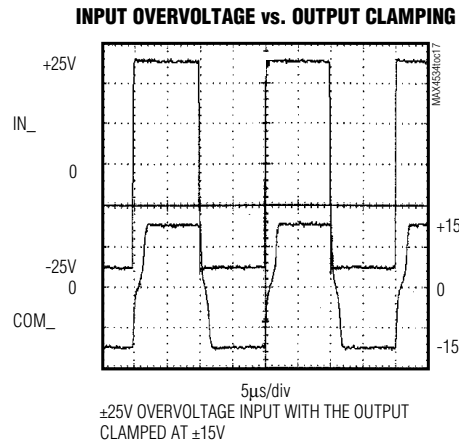
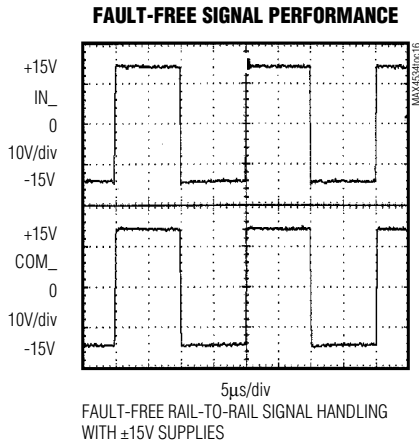
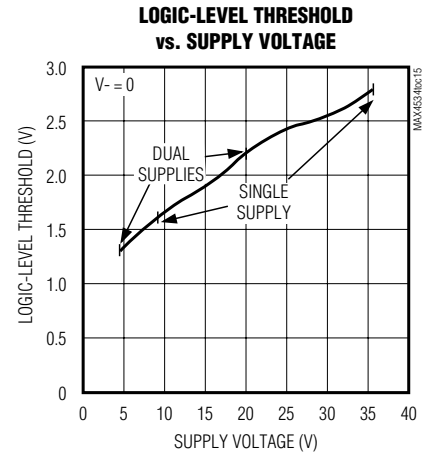
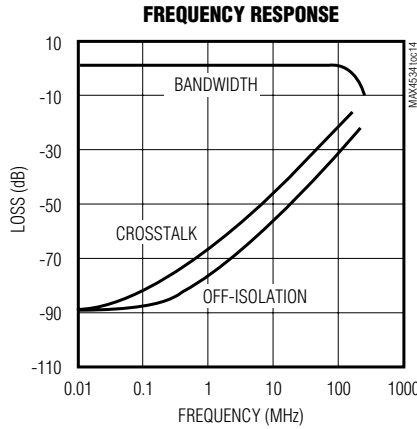
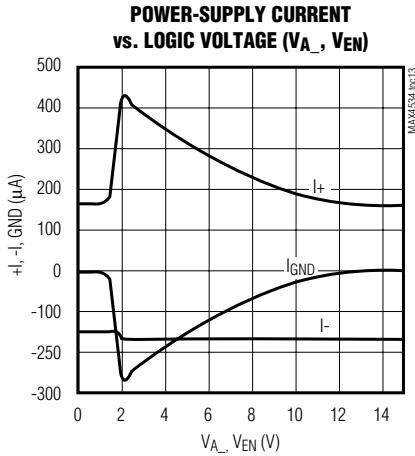



# Fault-Protected, High-Voltage, Single 4-to-1/Dual 2-to-1 Multiplexers

MAX4534/MAX4535

## Pin Descriptions

### MAX4534 (Single 4-to-1 Mux)

PIN	NAME	FUNCTION
1	A0	Address Bit 0
2	EN	Enable Input
3	V-	Negative Supply Voltage
4	NO1	Channel Input 1 (fault protected)
5	NO2	Channel Input 2 (fault protected)
6, 8, 9	N.C.	No connection
7	COM	Analog Output
10	NO4	Channel Input 4 (fault protected)
11	NO3	Channel Input 3 (fault protected)
12	V+	Positive Supply Voltage
13	GND	Ground
14	A1	Address Bit 1

### MAX4535 (Dual 2-to-1 Mux)

PIN	NAME	FUNCTION
1	A0	Address Bit 0
2	EN	Enable Input
3	V-	Negative Supply Voltage
4	NO1A	Channel Input 1A (fault protected)
5	NO2A	Channel Input 2A (fault protected)
6, 9, 14	N.C.	No connection
7	COMA	Mux Output A
8	COMB	Mux Output B
10	NO2B	Channel Input 2B (fault protected)
11	NO1B	Channel Input 1B (fault protected)
12	V+	Positive Supply Voltage
13	GND	Ground

## Truth Tables

### MAX4534 (Single 4-to-1 Mux)

A1	A0	EN	ON SWITCH
X	X	0	None
0	0	1	NO1
0	1	1	NO2
1	0	1	NO3
1	1	1	NO4

X = Don't care; logic 0:  $V_{AL} \leq +0.8$ ; logic 1:  $V_{AH} \geq +2.4V$

### MAX4535 (Dual 2-to-1 Mux)

A0	EN	COMA	COMB
X	0	None	None
0	1	NO1A	NO1B
1	1	NO2A	NO2B

X = Don't care; logic 0:  $V_{AL} \leq +0.8$ ; logic 1:  $V_{AH} \geq +2.4V$

## Detailed Description

The MAX4534/MAX4535 differ considerably from traditional fault-protected multiplexers, offering several advantages. First, they are constructed with two parallel FETs, allowing very low resistance when the switch is on. Second, they allow signals on the NO\_ pins that are within or beyond the supply rails to be passed through the switch to the COM terminal. This allows rail-

to-rail signal operation. Third, when a signal on VNO\_ exceeds the supply rails (i.e., a fault condition), the voltage on COM\_ is limited to the supply rails. Operation is identical for both fault polarities.

When the NO\_ voltage goes beyond supply rails (fault condition), the NO\_ input becomes high impedance regardless of the switch state or load resistance. When power is removed, and the fault protection is still in effect, the NO\_ terminals are a virtual open circuit. The fault can be up to  $\pm 40V$ , with  $V_+ = V_- = 0$ . If the switch is on, the COM\_ output current is furnished from the V+ or V- pin by "booster" FETs connected to each supply pin. These FETs can source or sink up to 10mA.

The COM\_ pins are not fault-protected. If a voltage source is connected to any COM\_ pin, it should be limited to the supply voltages. Exceeding the supply voltage will cause high currents to flow through the ESD protection diodes, damaging the device (see *Absolute Maximum Ratings*).

Figure 1 shows the internal construction, with the analog signal paths shown in bold. A single, normally open (NO) switch is shown. The analog switch is formed by the parallel combination of N-channel FET N1 and P-channel FET P1, which are driven on and off simultaneously, according to the input fault condition and the logic level state.

## Fault-Protected, High-Voltage, Single 4-to-1/Dual 2-to-1 Multiplexers

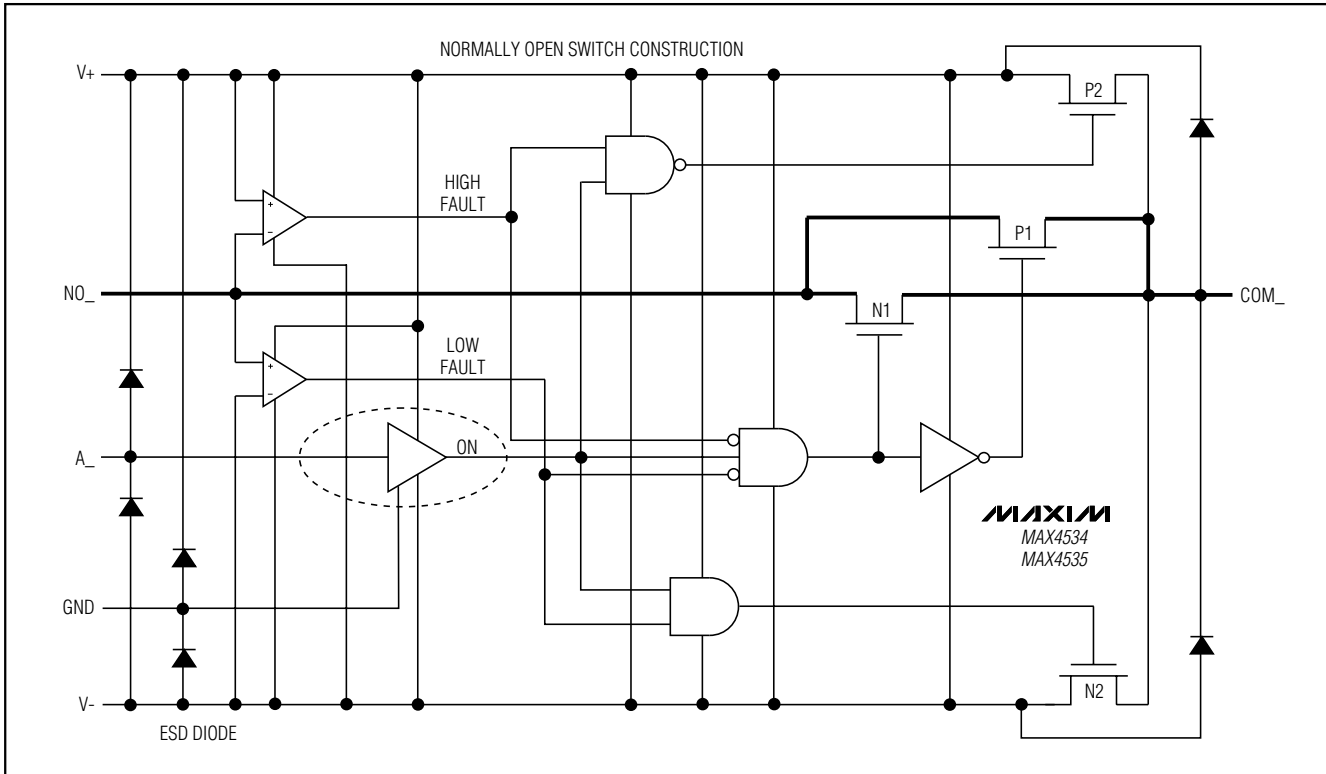

Figure 1. Functional Diagram

### NO<sub>-</sub> Input Voltage

The maximum allowable input voltage for safe operation depends on whether supplies are on or off and on the load configuration at the COM output. If COM is referred to a voltage other than ground, but within the supplies, VNO<sub>-</sub> may range higher or lower than the supplies, provided the absolute value of VNO<sub>-</sub> - VCOM<sub>-</sub> is less than 40V. For example, if the load is referred to +10V at COM<sub>-</sub>, then the NO<sub>-</sub> voltage range can be from +50V to -30V. As another example, if the load is connected to -10V at COM<sub>-</sub>, the NO<sub>-</sub> voltage range is limited to -50V to +30V.

If the supplies are ±15V and COM is referenced to ground through a load, the maximum NO<sub>-</sub> voltage is ±36V. If the supplies are off and the COM output is referenced to ground, the maximum NO<sub>-</sub> voltage is ±40V.

### Normal Operation

Two comparators continuously compare the voltage on the NO<sub>-</sub> pin with V<sub>+</sub> and V<sub>-</sub> supply voltages. When the signal on NO<sub>-</sub> is between V<sub>+</sub> and V<sub>-</sub>, the multiplexer behaves normally, with FETs N1 and P1 turning on and

off in response to A<sub>-</sub> signals (Figure 1). The parallel combination of N1 and P1 forms a low-value resistor between NO<sub>-</sub> and COM<sub>-</sub> so that signals pass equally well in either direction.

### Positive Fault Condition

When the signal on NO<sub>-</sub> exceeds V<sub>+</sub> by about 150mV, the positive fault comparator output goes high, turning off FETs N1 and P1 (Figure 1). This makes the NO<sub>-</sub> pin high impedance regardless of the switch state. If the switch state is "off," all FETs turn off, and both NO<sub>-</sub> and COM<sub>-</sub> are high impedance. If the switch state is "on," FET P2 turns on, clamping COM<sub>-</sub> to V<sub>+</sub>.

### Negative Fault Condition

When the signal on NO<sub>-</sub> goes about 150mV below V<sub>-</sub>, the negative fault comparator output goes high, turning off FETs N1 and P1 (Figure 1). This makes the NO pin high impedance regardless of the switch state. If the switch state is "off," all FETs turn off, and both NO<sub>-</sub> and COM<sub>-</sub> are high impedance. If the switch state is "on," FET N2 turns on, clamping COM<sub>-</sub> to V<sub>-</sub>.

# Fault-Protected, High-Voltage, Single 4-to-1/Dual 2-to-1 Multiplexers

MAX4534/MAX4535

## Transient Fault Condition

When a fast rising or falling transient on NO<sub>1</sub> exceeds V<sub>+</sub> or V<sub>-</sub>, the output (COM<sub>1</sub>) follows the input (NO<sub>1</sub>) to the supply rail with only a few nanoseconds delay. This delay is due to the switch on-resistance and circuit capacitance to ground. When the input transient returns to within the supply rails, however, there is a longer output recovery time. For positive faults, the recovery time is typically 2.5μs. For negative faults, the recovery time is typically 1.3μs. These values depend on the COM<sub>1</sub> output resistance and capacitance. The delays do not depend on the fault amplitude. Higher COM<sub>1</sub> output resistance and capacitance increase the recovery times.

## Non-Fault-Protected Pins

FETs N2 and P2 can source about ±10mA from V<sub>+</sub> or V<sub>-</sub> to the COM<sub>1</sub> pin in the fault condition (Figure 1). Ensure that if the COM<sub>1</sub> pin is connected to a low-impedance load, the 30mA absolute maximum current rating is never exceeded, both in normal and fault conditions.

The GND, COM<sub>1</sub>, EN, and A<sub>1</sub> pins do not have fault protection. Reverse ESD protection diodes are internally connected between GND, COM<sub>1</sub>, A<sub>1</sub>, EN, and both V<sub>+</sub> and V<sub>-</sub>. If a signal on GND, COM<sub>1</sub>, EN, or A<sub>1</sub> exceeds V<sub>+</sub> or V<sub>-</sub> by more than 300mV, one of these diodes will conduct. During normal operation, these reverse-biased ESD diodes leak a few nanoamps of current to V<sub>+</sub> and V<sub>-</sub>.

## Fault Protection Voltage and Power-Off

The maximum fault voltage on the NO<sub>1</sub> pins is ±40V from ground when the power is off. With ±15V supply voltages, the highest voltage on NO<sub>1</sub> can be V<sub>-</sub> + 40V, and the lowest voltage on NO<sub>1</sub> can be V<sub>+</sub> - 40V.

**Caution: Exceeding these limits can damage the IC.**

## Logic-Level Thresholds

The logic-level thresholds are CMOS and TTL compatible with V<sub>+</sub> = 4.5V to 16.5V.

## Applications Information

### Ground

There is no connection between the analog signal paths and GND. The analog signal paths consist of an N-channel and a P-channel MOSFET with their sources and drains paralleled, and their gates driven out of phase to V<sub>+</sub> and V<sub>-</sub> by the logic-level translators.

V<sub>+</sub> and GND power the internal logic and logic-level translators and set the input logic thresholds. The logic-level translators convert the logic levels to switched V<sub>+</sub> and V<sub>-</sub> signals to drive the gates of the channel MOSFETs. This drive signal is the only connection between the power supplies and the analog signals. GND, A<sub>1</sub>, EN, and COM<sub>1</sub> have ESD protection diodes to V<sub>+</sub> and V<sub>-</sub>.

### Supply Current Reduction

When the logic signals are driven rail-to-rail from 0 to +15V or -15V to +15V, the current consumption will be reduced from 300μA (typ) to 180μA.

### Power Supplies

The MAX4534/MAX4535 operate with bipolar supplies between ±4.5V and ±20V. The V<sub>+</sub> and V<sub>-</sub> supplies need not be symmetrical, but their sum cannot exceed the 44V absolute maximum rating.

The MAX4534/MAX4535 operate from single supplies between +9V and +36V when V<sub>-</sub> is connected to GND.

# Fault-Protected, High-Voltage, Single 4-to-1/Dual 2-to-1 Multiplexers

## Test Circuits/Timing Diagrams

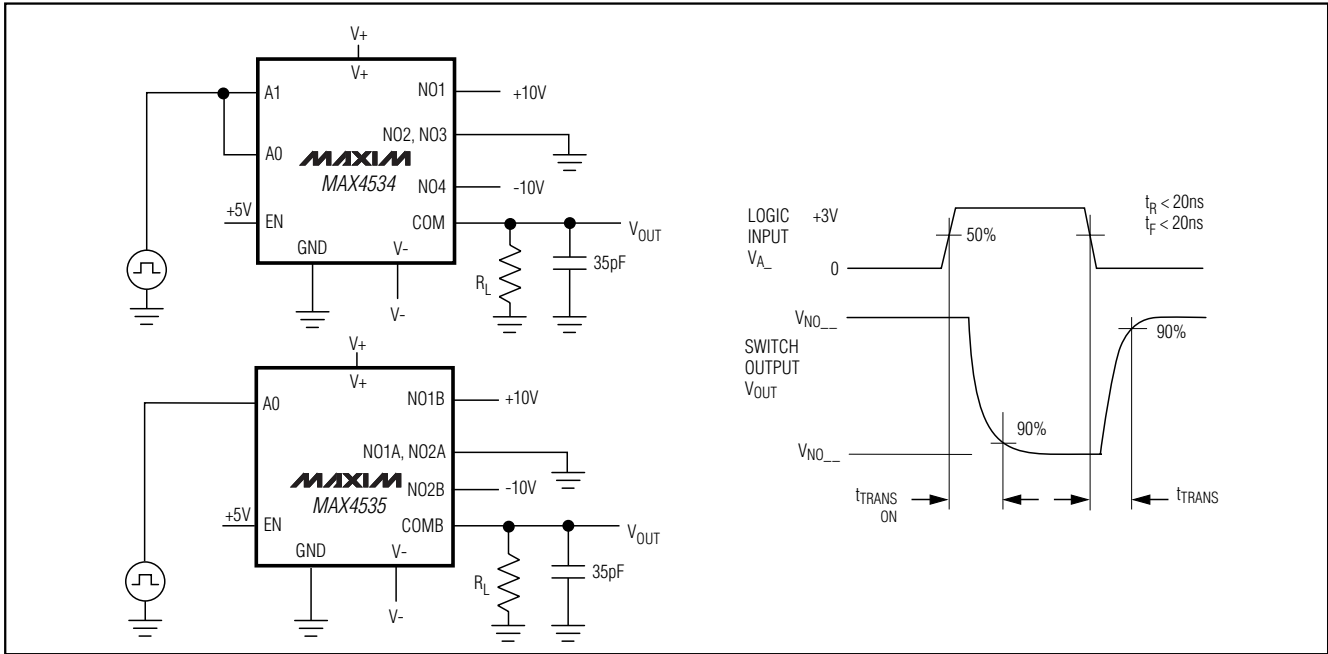

Figure 2. Address Transition Time

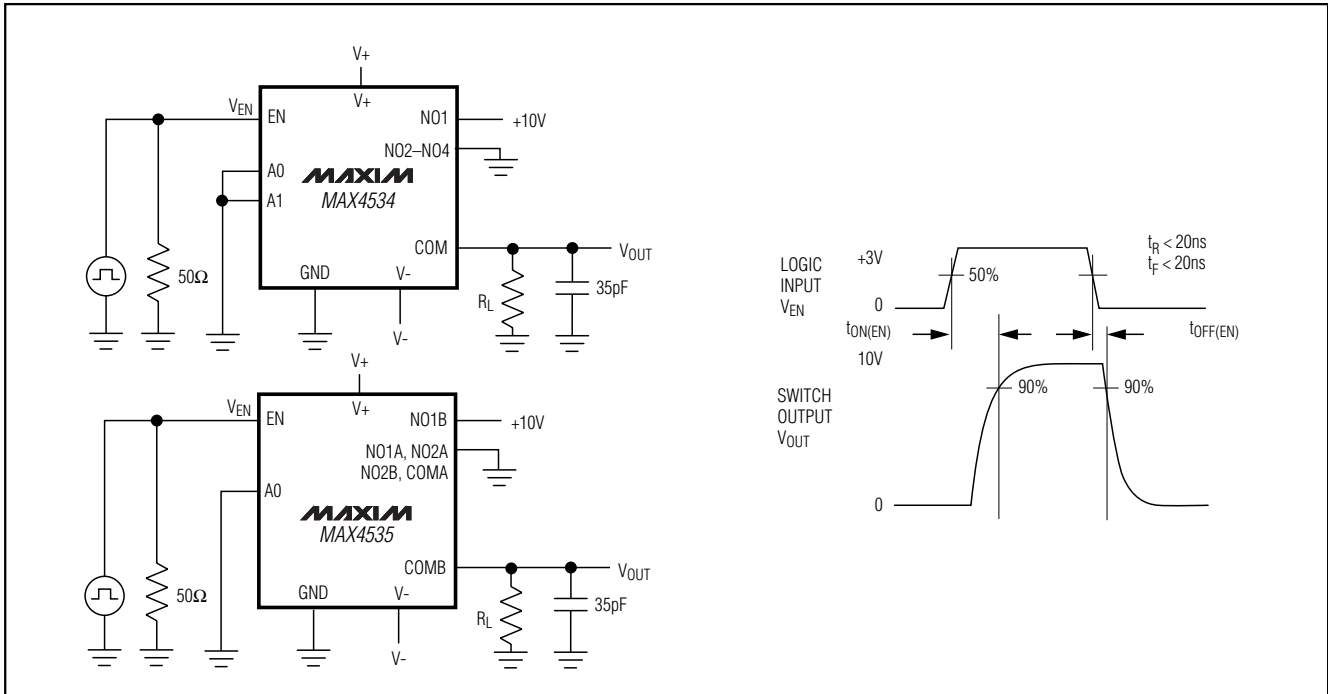

Figure 3. Enable Switching Time

# Fault-Protected, High-Voltage, Single 4-to-1/Dual 2-to-1 Multiplexers

## Test Circuits/Timing Diagrams (continued)

MAX4534/MAX4535

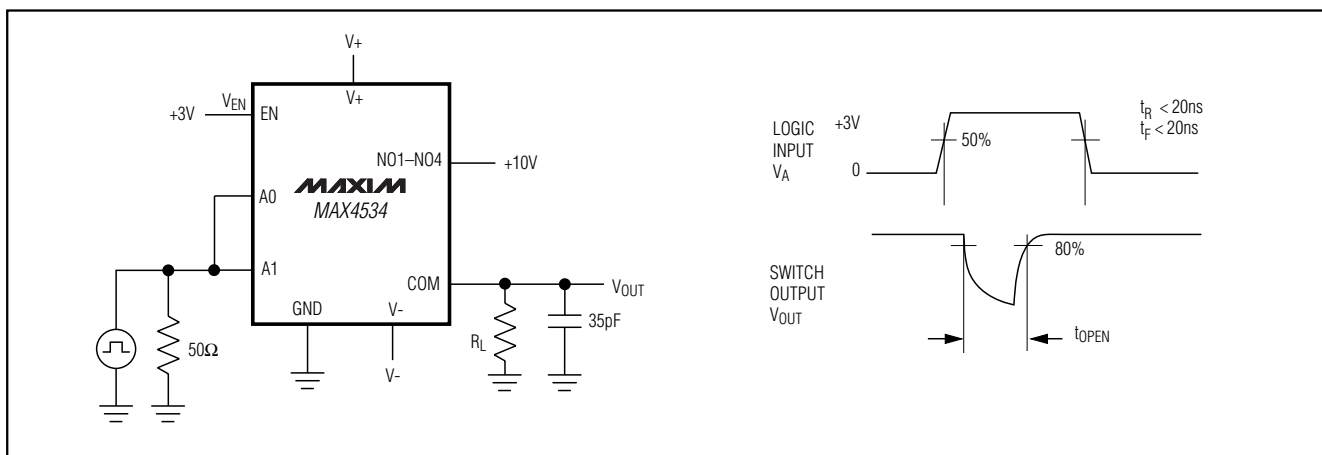

Figure 4. MAX4534 Break-Before-Make Interval

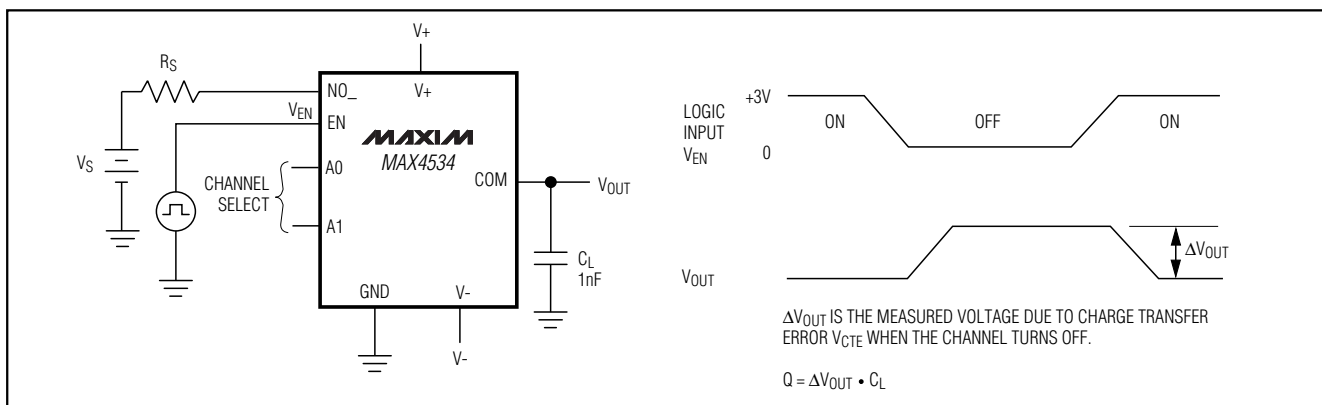

Figure 5. Charge Injection

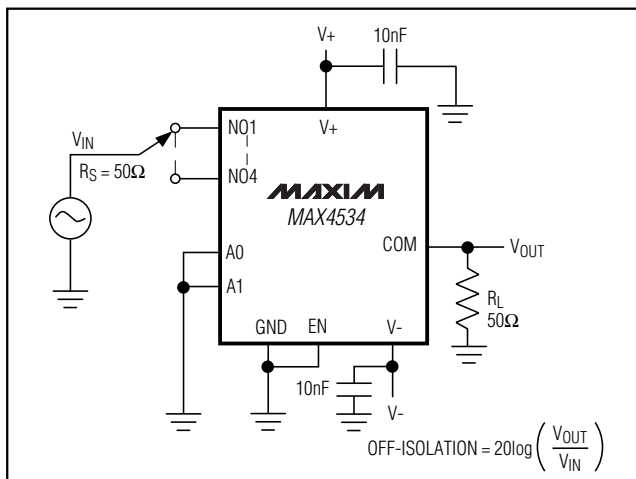

Figure 6. Off-Isolation

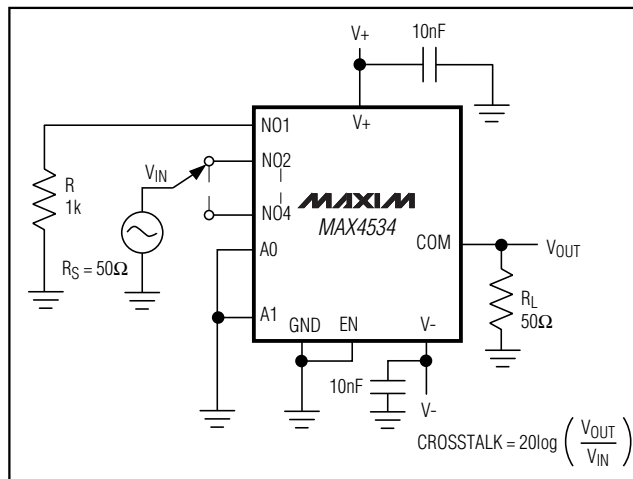

Figure 7. Crosstalk

# Fault-Protected, High-Voltage, Single 4-to-1/Dual 2-to-1 Multiplexers

## Test Circuits/Timing Diagrams (continued)

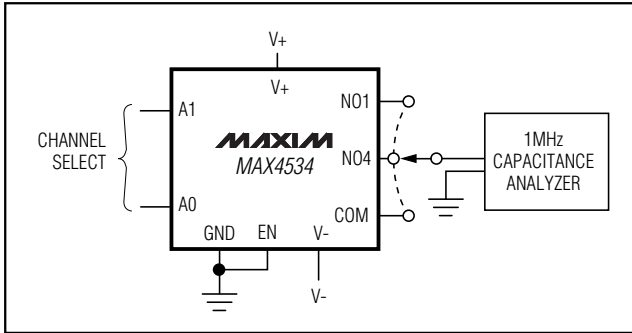

Figure 8. NO\_, COM\_ Capacitance

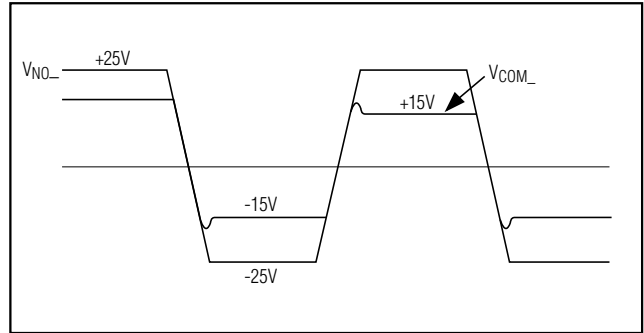

Figure 9. Transient Behavior of Fault Condition

## Chip Information

TRANSISTOR COUNT: 265

# Fault-Protected, High-Voltage, Single 4-to-1/Dual 2-to-1 Multiplexers

## Package Information

MAX4534/MAX4535

**TOP VIEW**

**BOTTOM VIEW**

**SIDE VIEW**

**END VIEW**

**LEAD TIP DETAIL**

**PACKAGE DIMENSIONS**

DIM.	DIMENSIONS	
	MILLIMETERS	INCHES
A	10.16	0.400
B	10.16	0.400
C	10.16	0.400
D	10.16	0.400
E	10.16	0.400
F	10.16	0.400
G	10.16	0.400
H	10.16	0.400
I	10.16	0.400
J	10.16	0.400
K	10.16	0.400
L	10.16	0.400
M	10.16	0.400
N	10.16	0.400
O	10.16	0.400
P	10.16	0.400
Q	10.16	0.400
R	10.16	0.400
S	10.16	0.400
T	10.16	0.400
U	10.16	0.400
V	10.16	0.400
W	10.16	0.400
X	10.16	0.400
Y	10.16	0.400
Z	10.16	0.400

JEDEC	N	VARIATIONS			
		MILLIMETERS		INCHES	
MO-153	N	MIN.	MAX.	MIN.	MAX.
AD	AD	1.27	1.27	0.500	0.500
AE	AE	1.27	1.27	0.500	0.500
AF-EP	AF-EP	1.27	1.27	0.500	0.500
AG	AG	1.27	1.27	0.500	0.500
AH-EP	AH-EP	1.27	1.27	0.500	0.500
AI	AI	1.27	1.27	0.500	0.500
AK	AK	1.27	1.27	0.500	0.500
AL	AL	1.27	1.27	0.500	0.500
AM-EP	AM-EP	1.27	1.27	0.500	0.500
AN	AN	1.27	1.27	0.500	0.500
AO	AO	1.27	1.27	0.500	0.500

**NOTES:**

- DIMENSIONS B AND C DO NOT INCLUDE FLASH.
- NO FLASH OR PROTRUSIONS NOT TO EXCEED 25 μm PER SIDE.
- CONTROLLING DIMENSION, MILLIMETERS.
- MEETS JEDEC OUTLINE MO-153 VARIATIONS FOR AO, AL, AE, AF, AH, AI, AM, AN, AO, AP, AR, AS, AT, AU, AV, AW, AX, AY, AZ.
- DIMENSIONS H AND Y APPLY TO EXPOSED PAD ONLY VERSIONS ONLY.
- EXPOSED PAD FLUSH WITH BOTTOM OF PACKAGE WITHIN 0.1mm.

**MAXIM**

PACKAGE OUTLINE, THRU, 4-LEAD JED, 14mm PITCH

REVISION	REVISION DATE	REV	✓
	01-08-05	C	

# Fault-Protected, High-Voltage, Single 4-to-1/Dual 2-to-1 Multiplexers

## Package Information (continued)

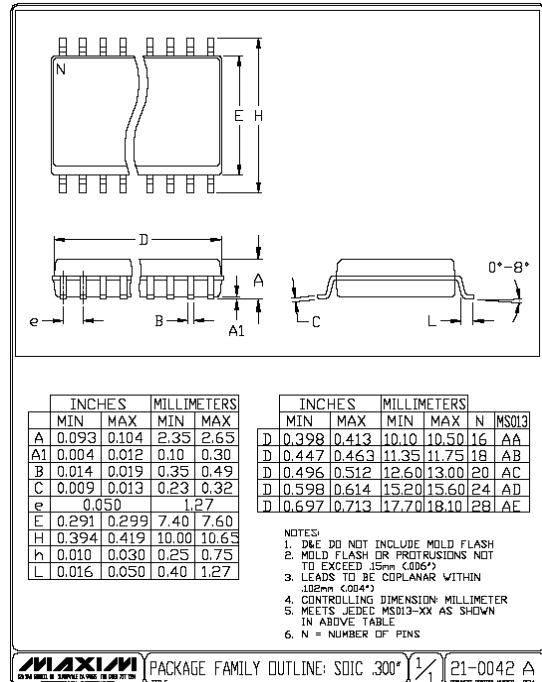
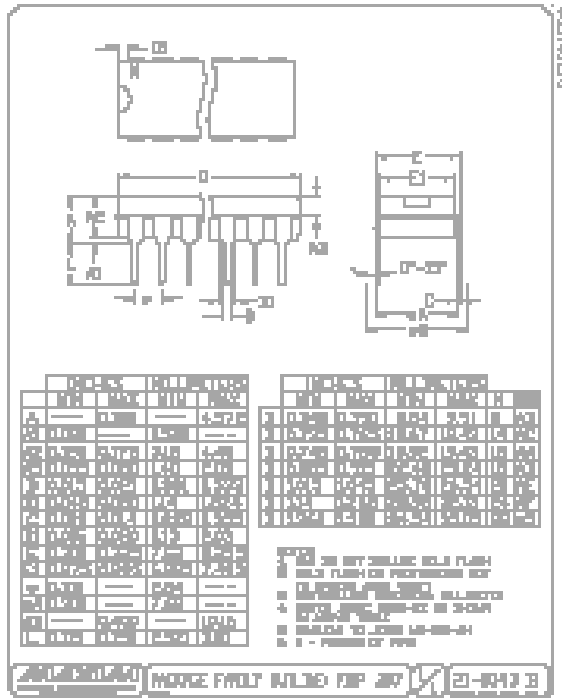

Maxim cannot assume responsibility for use of any circuitry other than circuitry entirely embodied in a Maxim product. No circuit patent licenses are implied. Maxim reserves the right to change the circuitry and specifications without notice at any time.