



# DirectDrive Video Amplifier with Reconstruction Filter and Analog Switch

MAX9505

## General Description

The MAX9505 filters and amplifies standard-definition video signals. Maxim's DirectDrive™ technology eliminates large output-coupling capacitors and sets the video black level to ground. An internal reconstruction filter smooths the steps and reduces the spikes on the video signal from the video digital-to-analog converter (DAC). The input of the MAX9505 can be directly connected to the output of a DAC. The MAX9505 provides a compact, integrated, and low-power solution.

The reconstruction filter typically has 3dB attenuation at 9MHz and 50dB attenuation at 27MHz, and ±1dB pass-band flatness to 5.5MHz.

Maxim's DirectDrive uses an integrated charge pump and a linear regulator to create a negative power supply to drive the sync below ground. The charge pump injects so little noise into the video output that the picture is visibly flawless.

The MAX9505 features an internal 1.7Ω analog switch that interfaces with a 4-pole multimedia jack. This switch allows one of the poles to be set as a video input, a video output, or a microphone input.

The MAX9505 is offered in space-saving 16-pin QSOP and 16-pin TQFN packages and is specified over the -40°C to +85°C extended temperature range.

## Applications

- Mobile Phones/Smartphones
- Space-Constrained, Low-Power Audio/Video Portable Devices

## Features

- ◆ DC-Coupled Output
- ◆ Direct Connection to Video DAC
- ◆ Video Output Black Level Set to Ground
- ◆ Video Reconstruction Filter with 50dB Attenuation at 27MHz
- ◆ 6dB Gain
- ◆ 1.7Ω RON Analog Switch
- ◆ 10nA Shutdown Supply Current
- ◆ 2.7V to 3.6V Single-Supply Operation

## Ordering Information

| PART*      | PIN-PACKAGE | PKG CODE | TOP MARK |
|------------|-------------|----------|----------|
| MAX9505EEE | 16 QSOP     | E16-4    | —        |
| MAX9505ETE | 16 TQFN     | T1633-4  | ACW      |

\*All devices are specified over the -40°C to +85°C operating temperature range.

Functional Diagram/Typical Operating Circuit and Pin Configurations appear at end of data sheet.

## Block Diagram

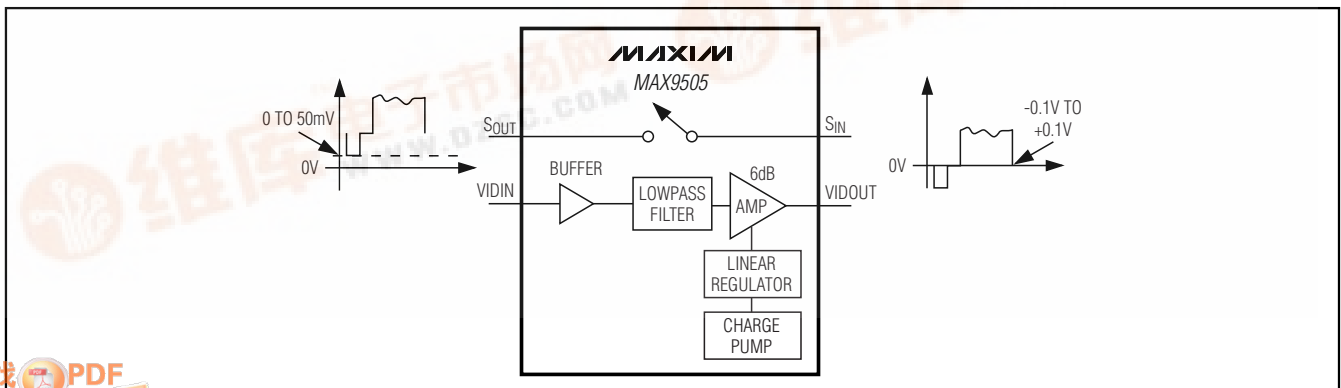

# DirectDrive Video Amplifier with Reconstruction Filter and Analog Switch

## ABSOLUTE MAXIMUM RATINGS

|   |  |   |   |
|---|--|---|---|
| V <sub>DD</sub> to SGND                             | -0.3V to +4V   | VIDOUT Short Circuit to V <sub>DD</sub> , SGND and the Greater of (V <sub>SS</sub> and -2V) | Continuous  |
| VIDIN to SGND                                       | -0.3V to +4V   | Continuous Current  | VIDIN, BIAS, MODE0, MODE1, S <sub>IN</sub> , S <sub>OUT</sub> ±20mA |
| BIAS to SGND  | -0.3V to (V <sub>DD</sub> + 0.3V)                                    | Continuous Power Dissipation (T <sub>A</sub> = +70°C)                                       | 16-Pin QSOP (derate 8.3mW/°C above +70°C) 667mW                     |
| MODE0, MODE1 to SGND                                | -0.3V to +4V   |   | 16-Pin TQFN (derate 15.6mW/°C above +70°C) 1349mW                   |
| S <sub>IN</sub> , S <sub>OUT</sub> , VIDOUT to SGND | (The greater of V <sub>SS</sub> and -2V) to (V <sub>DD</sub> + 0.3V) | Operating Temperature Range   | -40°C to +85°C  |
| CPV <sub>DD</sub> to CPGND                          | -0.3V to +4V   | Junction Temperature  | +150°C  |
| C1P, C1N, CPV <sub>SS</sub>                         | Capacitor Connection Only  | Storage Temperature Range   | -65°C to +150°C   |
| CPGND, SGND, GND                                    | -0.1V to +0.1V   | Lead Temperature (soldering, 10s)   | +300°C  |
| CPV <sub>SS</sub> to V <sub>SS</sub>                | -0.1V to +0.1V   |   |   |

Stresses beyond those listed under "Absolute Maximum Ratings" may cause permanent damage to the device. These are stress ratings only, and functional operation of the device at these or any other conditions beyond those indicated in the operational sections of the specifications is not implied. Exposure to absolute maximum rating conditions for extended periods may affect device reliability.

## ELECTRICAL CHARACTERISTICS

(V<sub>DD</sub> = CPV<sub>DD</sub> = MODE1 = 3.0V, MODE0 = SGND = GND = CPGND = 0V, C1 = C2 = C3 = C4 = 1μF, R<sub>BIAS</sub> = 100kΩ, T<sub>A</sub> = T<sub>MIN</sub> to T<sub>MAX</sub>, R<sub>L</sub> = 150Ω to SGND, unless otherwise noted. V<sub>VIDIN</sub> = 286mV, gain = 6dB. Typical values are at V<sub>DD</sub> = CPV<sub>DD</sub> = MODE1 = 3.0V, T<sub>A</sub> = +25°C, unless otherwise noted.) (Note 1)

| PARAMETER                    | SYMBOL                              | CONDITIONS   | MIN   | TYP  | MAX   | UNITS |
|------------------------------|-------------------------------------|--|-------|------|-------|-------|
| Supply Voltage Range         | V <sub>DD</sub> , CPV <sub>DD</sub> | Guaranteed by DC voltage gain and quiescent supply current   | 2.7   |      | 3.6   | V     |
| Quiescent Supply Current     | I <sub>DD</sub>                     | V <sub>DD</sub> = 3.6V (I <sub>DD</sub> = I <sub>VDD</sub> + I <sub>CPVDD</sub> , R <sub>L</sub> = ∞)        |       | 12   | 15    | mA    |
| Shutdown Supply Current      | I <sub>SHDN</sub>                   | V <sub>DD</sub> = 3.6V (I <sub>SHDN</sub> = I <sub>VDD</sub> + I <sub>CPVDD</sub> ), S <sub>HDN</sub> = SGND |       | 0.01 | 1     | μA    |
| Bias Voltage                 | V <sub>BIAS</sub>                   |  |       | 1    |       | V     |
| <b>VIDEO AMPLIFIER</b>       |                                     |  |       |      |       |       |
| Input Voltage Range          | V <sub>RANGE</sub>                  | Guaranteed by DC voltage gain, V <sub>DD</sub> = 2.7V  | -0.10 |      | +1.05 | V     |
|                              |                                     | Guaranteed by DC voltage gain, V <sub>DD</sub> = 3V  | -0.10 |      | +1.28 |       |
| Input Current                | I <sub>IN</sub>                     | V <sub>DD</sub> = 2.7V   | -2.5  |      | +2.5  | μA    |
| Input Resistance             | R <sub>IN</sub>                     |  |       | 1    |       | MΩ    |
| DC Voltage Gain (Note 2)     | A <sub>V</sub>                      | V <sub>DD</sub> = 2.7V to 3.6V   | 5.5   | 6    | 6.5   | dB    |
| Output Black Level (Note 3)  |                                     | V <sub>DD</sub> = 2.7V   | -0.1  | 0    | +0.1  | V     |
| Output Short-Circuit Current | I <sub>SC</sub>                     | Sinking or sourcing  |       | 50   |       | mA    |
| Output Resistance            | R <sub>OUT</sub>                    |  |       | 0.01 |       | Ω     |
| Shutdown Output Impedance    |                                     | MODE1 = MODE0 = SGND   |       | 4    |       | kΩ    |
| VIDOUT Leakage Current       |                                     | MODE1 = MODE0 = V <sub>DD</sub>  |       | 0.01 |       | μA    |
|                              |                                     | MODE1 = SGND and MODE0 = V <sub>DD</sub>   |       | 0.01 |       |       |

# DirectDrive Video Amplifier with Reconstruction Filter and Analog Switch

**MAX9505**

## ELECTRICAL CHARACTERISTICS (continued)

( $V_{DD} = CPV_{DD} = MODE1 = 3.0V$ ,  $MODE0 = SGND = GND = CPGND = 0V$ ,  $C1 = C2 = C3 = C4 = 1\mu F$ ,  $R_{BIAS} = 100k\Omega$ ,  $T_A = T_{MIN}$  to  $T_{MAX}$ .  $R_L = 150\Omega$  to  $SGND$ , unless otherwise noted.  $V_{VIDIN} = 286mV$ , gain = 6dB. Typical values are at  $V_{DD} = CPV_{DD} = MODE1 = 3.0V$ ,  $T_A = +25^\circ C$ , unless otherwise noted.) (Note 1)

| PARAMETER                              | SYMBOL   | CONDITIONS   | MIN   | TYP   | MAX | UNITS    |
|--|----------|--|---|-------|-----|----------|
| <b>ANALOG SWITCH</b>                   |          |  |   |       |     |          |
| On-Resistance                          | $R_{ON}$ | MODE0 = $V_{DD}$ ,<br>$I_{SIN} = 10mA$   | MODE1 = $V_{DD}$  | 1.7   | 4.4 | $\Omega$ |
|  |          |  | MODE1 = $SGND$  | 1.2   | 2.5 |          |
| On-Resistance Flatness (Note 4)        |          | MODE0 = $V_{DD}$ ,<br>$I_{SIN} = 10mA$ , $V_{DD} = 3V$   | MODE1 = $V_{DD}$  | 0.5   | 0.9 | $\Omega$ |
|  |          |  | MODE1 = $SGND$  | 0.3   | 0.5 |          |
| $S_{OUT}$ Off-Leakage Current (Note 5) |          | MODE0 = $SGND$ , $V_{DD} = 3.6V$ , $V_{SIN} = 0.3V$ ,<br>$3.3V$ , $V_{SOUT} = 3.3V$ , $0.3V$       | -1  |       | +1  | nA       |
| $S_{IN}$ On-Leakage Current (Note 5)   |          | MODE0 = $V_{DD}$ , $V_{DD} = 3.6V$ , $V_{SIN} = 0.3V$ ,<br>$3.3V$ , $V_{SOUT} = 3.3V$ , $0.3V$     | -1  |       | +1  | nA       |
| Turn-On Time                           |          | $V_{SIN} = 1.5V$ , $R_L = 300\Omega$ , $C_L = 35pF$ ,<br>Figure 1; $V_{IH} = 1.5V$ , $V_{IL} = 0V$ |   | 35    | 60  | ns       |
| Turn-Off Time                          |          | $V_{SIN} = 1.5V$ ; $R_L = 300\Omega$ , $C_L = 35pF$ ,<br>Figure 1; $V_{IH} = 1.5V$ , $V_{IL} = 0V$ |   | 50    | 80  | ns       |
| Charge Injection                       |          | $V_{GEN} = 1.5V$ , $R_{GEN} = 0\Omega$ , $C_L = 1nF$ ,<br>Figure 2                                 |   | 20    |     | pC       |
| Off-Isolation                          |          | MODE0 = $SGND$ , $f = 10MHz$ ;<br>$V_{SOUT} = 1V_{P-P}$ , $R_L = 50\Omega$ , $C_L = 5pF$           |   | 30    |     | dB       |
|  |          |  | MODE0 = $SGND$ , $f = 1MHz$ ; $V_{SOUT} = 1V_{P-P}$ ,<br>$R_L = 50\Omega$ , $C_L = 5pF$ |       | 50  |          |
| On-Channel -3dB Bandwidth              |          | MODE0 = $V_{DD}$ , signal = 0dBm, $R_L = 50\Omega$ ,<br>$C_L = 5pF$                                |   | 200   |     | MHz      |
| Total Harmonic Distortion              |          | MODE0 = $V_{DD}$ , $V_{SIN} = 2V_{P-P}$ , $R_L = 600\Omega$  |   | 0.025 |     | %        |
| $S_{OUT}$ Off-Capacitance              |          | MODE0 = $SGND$ , $f = 1MHz$  |   | 18    |     | pF       |
| Switch On-Capacitance                  |          | MODE0 = $V_{DD}$ , $f = 1MHz$  |   | 60    |     | pF       |
| <b>CROSSTALK (VIDEO TO AUDIO)</b>      |          |  |   |       |     |          |
| VIDIN to $S_{IN}$                      |          | MODE1 = MODE0 = $V_{DD}$ , $f = 20kHz$ ,<br>$1V_{P-P}$ at VIDIN                                    |   | 100   |     | dB       |
| VIDOUT to $S_{IN}$                     |          | MODE1 = $V_{DD}$ , MODE0 = $SGND$ ,<br>$f = 20kHz$ , $2V_{P-P}$ at VIDOUT                          |   | 85    |     | dB       |
| <b>CHARGE PUMP</b>                     |          |  |   |       |     |          |
| Switching Frequency                    |          |  | 150   | 250   | 300 | kHz      |
| <b>LOGIC SIGNALS (MODE0, MODE1)</b>    |          |  |   |       |     |          |
| Logic-Low Threshold                    | $V_{IL}$ | $V_{DD} = 2.7V$ to $3.6V$  |   |       | 0.5 | V        |
| Logic-High Threshold                   | $V_{IH}$ | $V_{DD} = 2.7V$ to $3.6V$  | 1.5   |       |     | V        |
| Logic Input Current                    | $I_{IL}$ |  |   |       | 1   | $\mu A$  |

# DirectDrive Video Amplifier with Reconstruction Filter and Analog Switch

## AC ELECTRICAL CHARACTERISTICS

( $V_{DD} = CPV_{DD} = MODE1 = 3.0V$ ,  $MODE0 = SGND = GND = CPGND = 0V$ ,  $C1 = C2 = C3 = C4 = 1\mu F$ ,  $R_{BIAS} = 100k\Omega$ ,  $T_A = T_{MIN}$  to  $T_{MAX}$ .  $R_L = 150\Omega$  to  $SGND$ , unless otherwise noted.  $V_{VIDIN} = 286mV$ , gain = 6dB. Typical values are at  $V_{DD} = CPV_{DD} = MODE1 = 3.0V$ ,  $T_A = +25^\circ C$ , unless otherwise noted.) (Note 1)

| PARAMETER                          | SYMBOL    | CONDITIONS  | MIN          | TYP  | MAX | UNITS    |
|------------------------------------|-----------|---|--------------|------|-----|----------|
| Passband Flatness                  |           | $V_{DD} = 2.7V$ , $f = 100kHz$ to $5.5MHz$  | -1           | 0    | +1  | dB       |
| Attenuation                        |           | $V_{DD} = 2.7V$ ,<br>$VIDOUT = 2V_{P-P}$ , attenuation<br>is referred to $100kHz$                         |              | 3    |     | dB       |
|                                    |           |   | $f = 9.1MHz$ |      |     |          |
|                                    |           |   | 35           | 50   |     |          |
| Power-Supply Rejection Ratio       | PSRR      | $f = 100kHz$  |              | 62   |     | dB       |
| Output Impedance                   | $Z_{OUT}$ | $f = 5MHz$  |              | 0.5  |     | $\Omega$ |
| Differential Gain Error            | DG        | NTSC, $VIDOUT = 2V_{P-P}$   |              | 0.1  |     | %        |
| Differential Phase Error           | DP        | NTSC, $VIDOUT = 2V_{P-P}$   |              | 0.2  |     | degrees  |
| 2T Pulse-to-Bar K Rating           |           | $2T = 250ns$ , bar time is $18\mu s$ , the beginning 2.5% and the ending 2.5% of the bar time are ignored |              | -0.3 |     | K%       |
| 2T Pulse Response                  |           | $2T = 250ns$  |              | 0.3  |     | K%       |
| 2T Bar Response                    |           | $2T = 250ns$ , bar time is $18\mu s$ , the beginning 2.5% and the ending 2.5% of the bar time are ignored |              | 0.7  |     | K%       |
| Nonlinearity                       |           | 5-step staircase  |              | 0.2  |     | %        |
| Group Delay Distortion             | $D_{Dt}$  | $100kHz$ to $5.5MHz$  |              | 10   |     | ns       |
| $VIDOUT$ Capacitive-Load Stability | $C_L$     | $V_{OUT} = 2V_{P-P}$ , no sustained oscillations  |              | 20   |     | pF       |
| Peak Signal-to-RMS Noise           | SNR       | $100kHz$ to $5.5MHz$  |              | 64   |     | dB       |
| Enable Time                        | $t_{ON}$  | $VIDIN = 0.5V$ , $VIDOUT$ settled to within 1% of the final voltage                                       |              | 0.2  |     | ms       |
| Disable Time                       | $t_{OFF}$ | $VIDIN = 0.5V$ , $VIDOUT$ settled to below 1% of the output voltage                                       |              | 0.1  |     | ms       |

**Note 1:** All devices are 100% production tested at  $T_A = +25^\circ C$ . Specifications over temperature are guaranteed by design.

**Note 2:** Voltage gain ( $A_V$ ) is a two-point measurement in which the output voltage swing is divided by the input voltage swing.

**Note 3:** With an output load attached, this offset will directly contribute to quiescent current.

**Note 4:** Flatness is defined as the difference between the maximum and minimum value of on-resistance as measured over the specified analog signal ranges.

**Note 5:** Guaranteed by design.

# DirectDrive Video Amplifier with Reconstruction Filter and Analog Switch

## Timing Diagrams

MAX9505

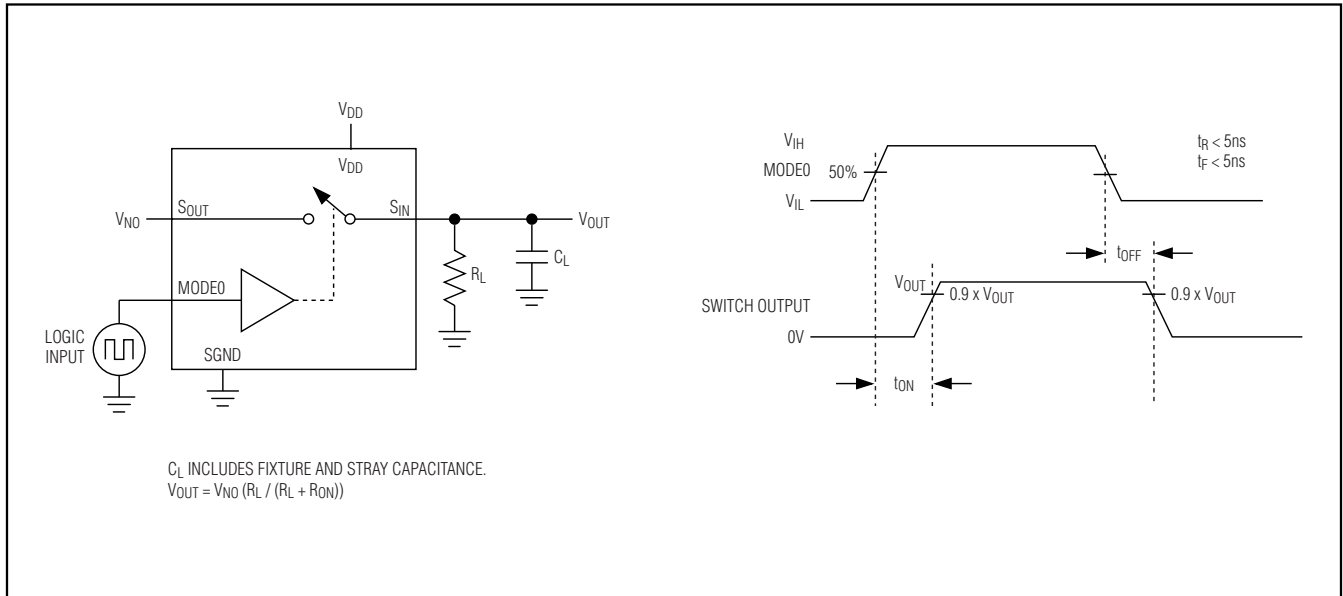

Figure 1. Analog Switch Turn-On/Off Time

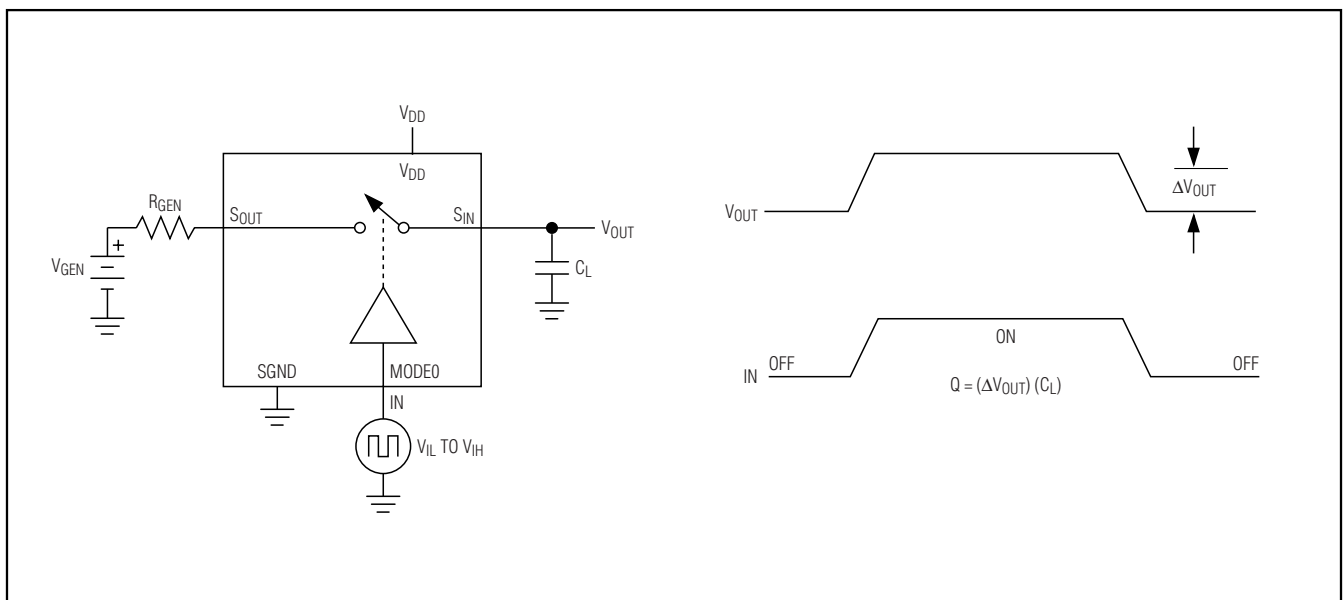
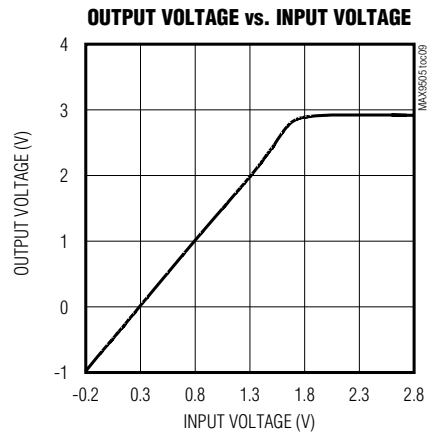
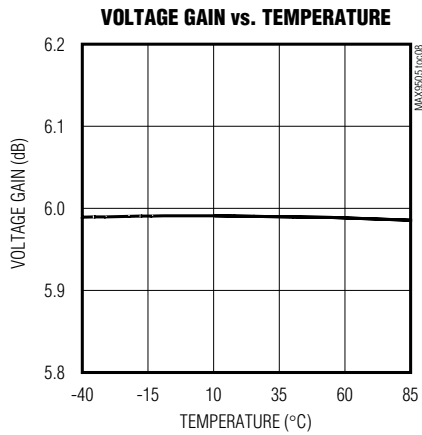
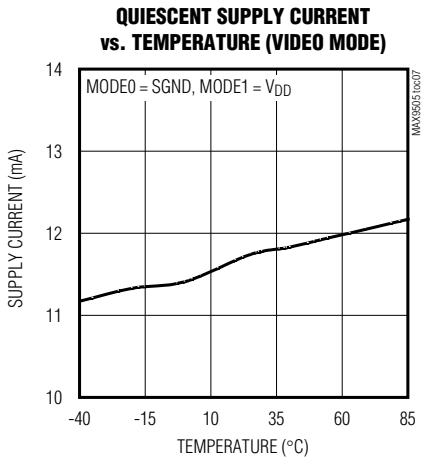
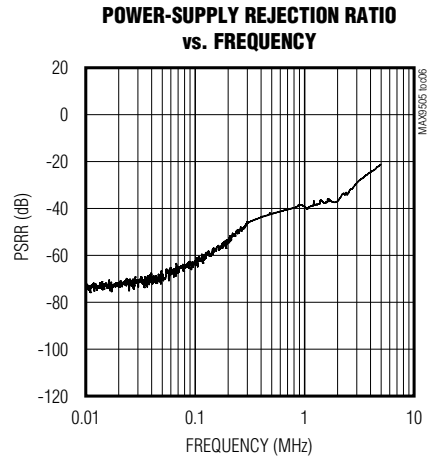
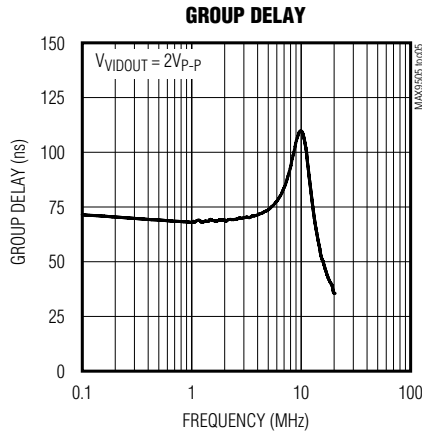
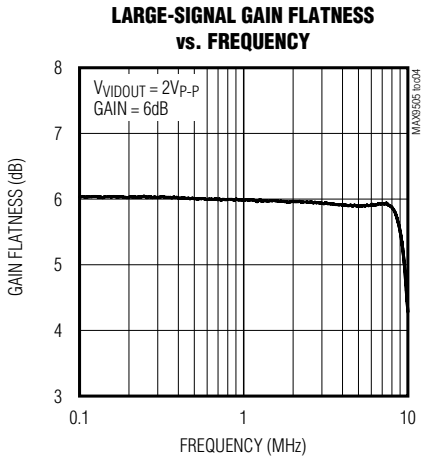
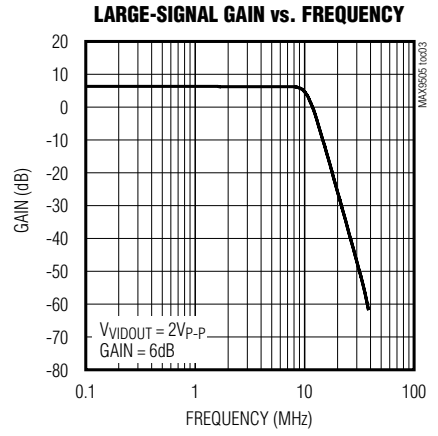
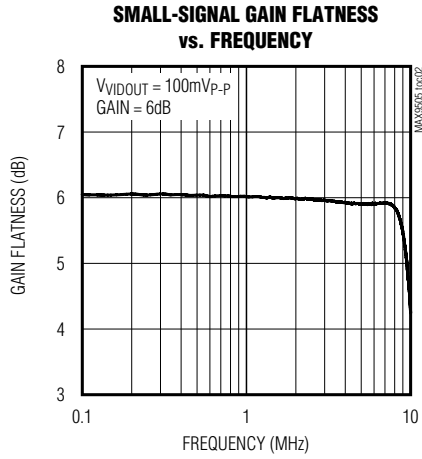
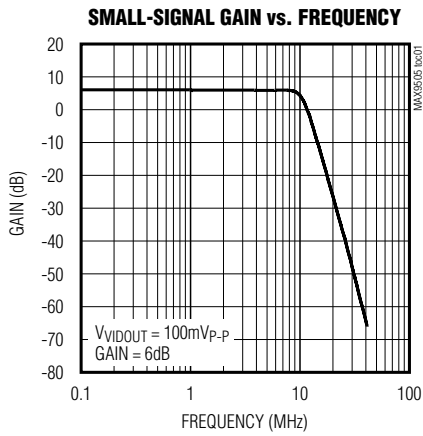

Figure 2. Charge Injection

# DirectDrive Video Amplifier with Reconstruction Filter and Analog Switch

## Typical Operating Characteristics

( $V_{DD} = CPV_{DD} = MODE1 = 3.0V$ ,  $MODE0 = SGND = GND = CPGND = 0V$ , no load,  $C1 = C2 = C3 = C4 = 1\mu F$ ,  $R_{BIAS} = 100k\Omega$ ,  $T_A = T_{MIN}$  to  $T_{MAX}$ .  $R_{IN} = 150\Omega$  to  $SGND$ , unless otherwise noted.  $V_{VIDIN} = 286mV$ , gain = 6dB. Typical values are at  $T_A = +25^\circ C$ , unless otherwise noted.)



# DirectDrive Video Amplifier with Reconstruction Filter and Analog Switch

## Typical Operating Characteristics (continued)

( $V_{DD} = CPV_{DD} = MODE1 = 3.0V$ ,  $MODE0 = SGND = GND = CPGND = 0V$ , no load,  $C1 = C2 = C3 = C4 = 1\mu F$ ,  $R_{BIAS} = 100k\Omega$ ,  $T_A = T_{MIN}$  to  $T_{MAX}$ .  $R_{IN} = 150\Omega$  to  $SGND$ , unless otherwise noted.  $V_{VIDIN} = 286mV$ , gain = 6dB. Typical values are at  $T_A = +25^\circ C$ , unless otherwise noted.)

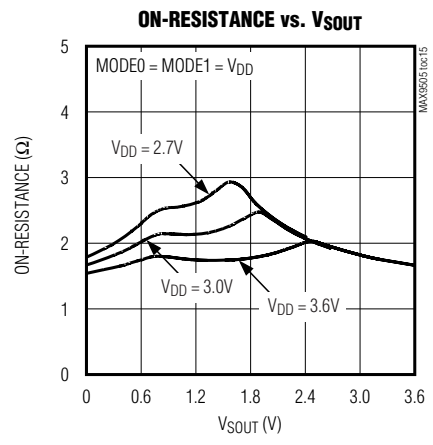
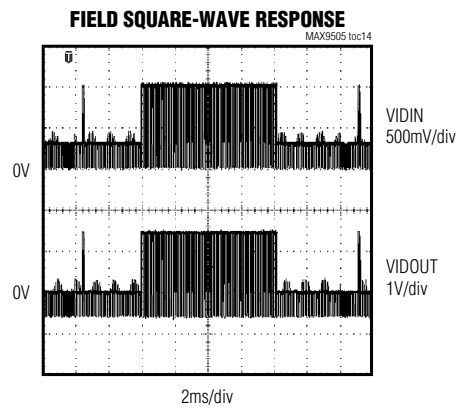
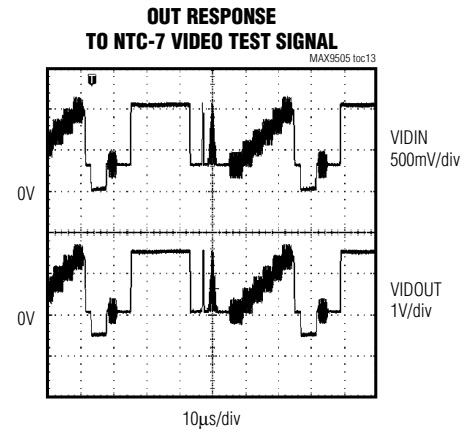
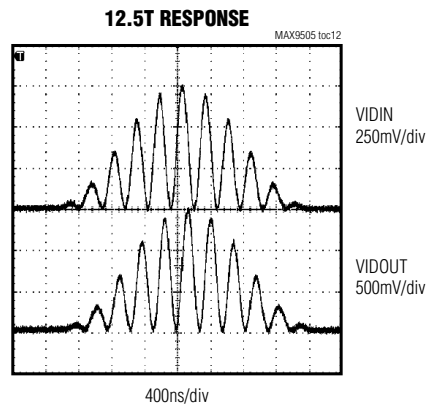
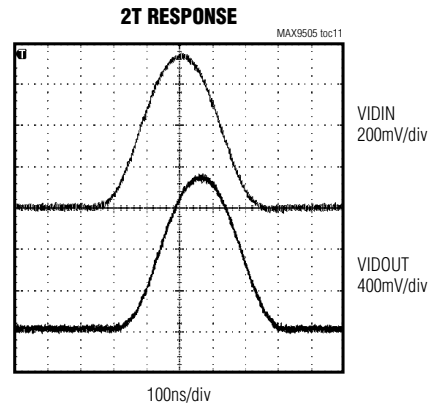
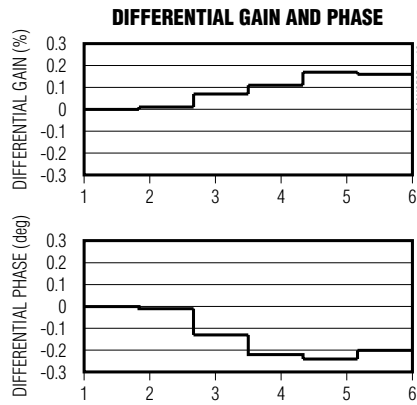

# DirectDrive Video Amplifier with Reconstruction Filter and Analog Switch

## Typical Operating Characteristics (continued)

( $V_{DD} = CPV_{DD} = MODE1 = 3.0V$ ,  $MODE0 = SGND = GND = CPGND = 0V$ , no load,  $C1 = C2 = C3 = C4 = 1\mu F$ ,  $R_{BIAS} = 100k\Omega$ ,  $T_A = T_{MIN}$  to  $T_{MAX}$ .  $R_{IN} = 150\Omega$  to  $SGND$ , unless otherwise noted.  $V_{VIDIN} = 286mV$ , gain = 6dB. Typical values are at  $T_A = +25^\circ C$ , unless otherwise noted.)

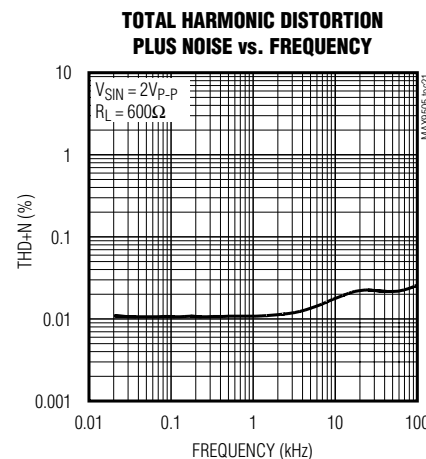
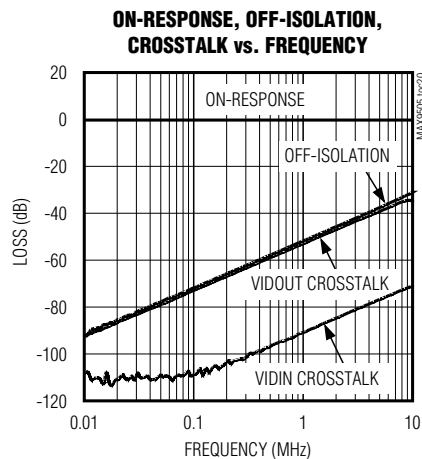
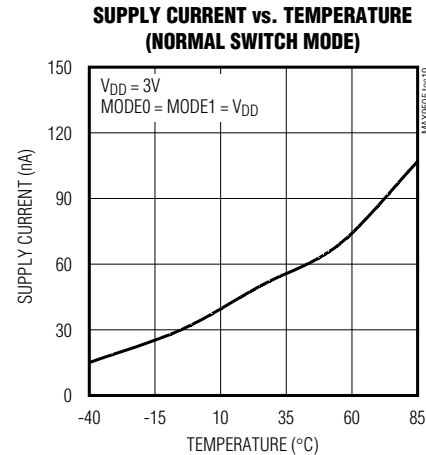
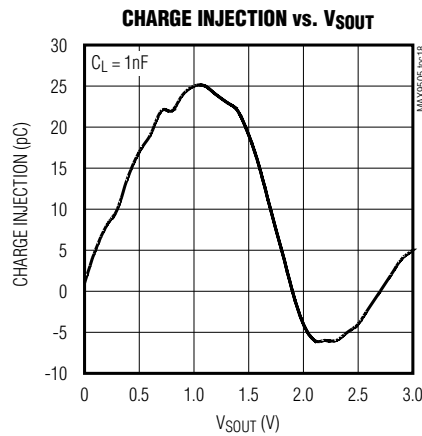
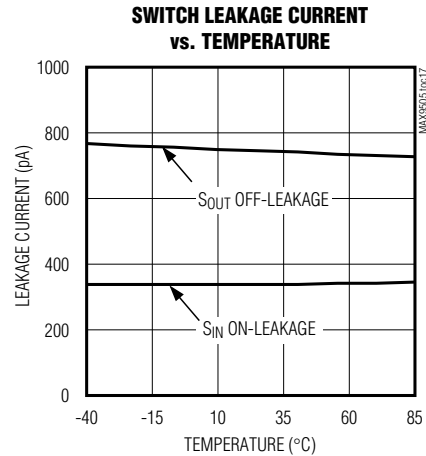
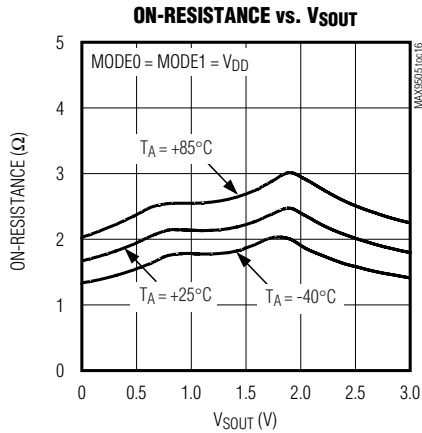



# DirectDrive Video Amplifier with Reconstruction Filter and Analog Switch

## Pin Description

MAX9505

| PIN  |      | NAME              | FUNCTION   |
|------|------|-------------------|--|
| QSOP | TQFN |                   |  |
| 1    | 15   | V <sub>SS</sub>   | Negative Power Supply. Connect to CPV <sub>SS</sub> .                                    |
| 2    | 16   | CPV <sub>SS</sub> | Charge-Pump Negative Power Supply. Bypass with a 1μF capacitor to CPGND.                 |
| 3    | 1    | C1N               | Charge-Pump Flying Capacitor Negative Terminal. Connect a 1μF capacitor from C1P to C1N. |
| 4    | 2    | CPGND             | Charge-Pump Power Ground   |
| 5    | 3    | C1P               | Charge-Pump Flying Capacitor Positive Terminal. Connect a 1μF capacitor from C1P to C1N. |
| 6    | 4    | CPV <sub>DD</sub> | Charge-Pump Positive Power Supply. Bypass with a 1μF capacitor to CPGND.                 |
| 7    | 5    | BIAS              | Common-Mode Voltage. Connect a 100kΩ resistor from BIAS to SGND.                         |
| 8    | 6    | SGND              | Signal Ground. Connect to GND.   |
| 9    | 7    | VIDIN             | Video Input  |
| 10   | 8    | MODE0             | Mode Logic Input 0. See Table 1.   |
| 11   | 9    | MODE1             | Mode Logic Input 1. See Table 1.   |
| 12   | 10   | GND               | Ground. Connect to SGND.   |
| 13   | 11   | V <sub>DD</sub>   | Positive Power Supply. Bypass with a 1μF capacitor to SGND.                              |
| 14   | 12   | S <sub>OUT</sub>  | Analog Switch Output   |
| 15   | 13   | VIDOUT            | Video Output   |
| 16   | 14   | S <sub>IN</sub>   | Analog Switch Input  |
| —    | EP   | EP                | Exposed Paddle. Connect to GND.  |

## Detailed Description

The MAX9505 completely eliminates the need for capacitors in the video output by using Maxim's DirectDrive technology that includes an inverting charge pump and linear regulator. The charge pump and linear regulator create a clean negative supply allowing the amplifier output to swing below ground. The amplifier output can swing both positive and negative so that the video signal black level can be placed at ground. The MAX9505 features a six-pole, Butterworth filter to perform reconstruction filtering on the video input signal from the DAC.

### DirectDrive Background

Integrated video filter/amplifier circuits operating from a single, positive supply usually create video output signals that are level-shifted above ground to keep the signal within the linear range of the output amplifier. For applications in which the positive DC level shift of the video signal is not acceptable, a series capacitor can be inserted in the output connection in an attempt to eliminate the positive DC level shift. The series capacitor cannot truly level shift a video signal because the

average level of the video varies with picture content. The series capacitor biases the video output signal around ground, but the actual level of the video signal can vary significantly depending upon the RC time constant and the picture content.

The series capacitor creates a highpass filter. Since the lowest frequency in video is the frame rate, which can be between 24Hz and 30Hz, the pole of the highpass filter should ideally be an order of magnitude lower in frequency than the frame rate. Therefore, the series capacitor must be very large, typically from 220μF to 3000μF. For space-constrained equipment, the series capacitor is unacceptable. Changing from a single series capacitor to a SAG network that requires two smaller capacitors can only reduce space and cost slightly.

The series capacitor in the usual output connection also prevents damage to the output amplifier if the connector is shorted to a supply or to ground. While the output connection of the MAX9505 does not have a series capacitor, the MAX9505 will not be damaged if the connector is shorted to a supply or to ground (see the *Short-Circuit Protection* section).

## DirectDrive Video Amplifier with Reconstruction Filter and Analog Switch

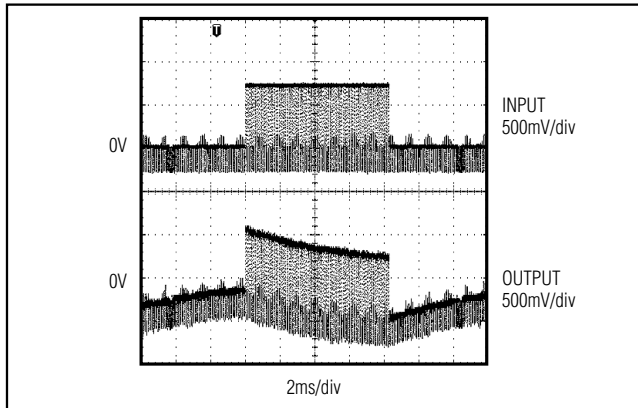

Figure 3. AC-Coupled Output

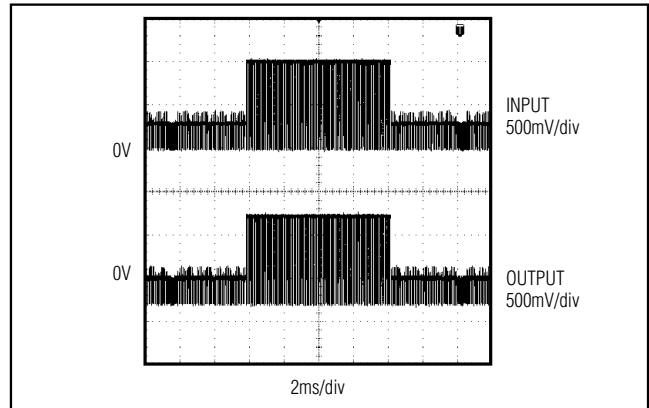

Figure 4. DirectDrive Output

### Video Amplifier

Typically, the black level of the video signal created by the video DAC is around 300mV. The MAX9505 shifts the black level to ground at the output. Therefore, the active video is above ground, and sync is below ground. The amplifier needs a negative supply for its output stage to remain in its linear region when driving sync below ground.

The MAX9505 has an integrated charge pump and linear regulator to create a low-noise negative supply from the positive supply voltage. The charge pump inverts the positive supply to create a raw negative voltage that is then fed into the linear regulator, which outputs -2V. The linear regulator filters out the charge-pump noise.

### Comparison Between DirectDrive Output and AC-Coupled Output

The actual level of the video signal varies less with a DirectDrive output than an AC-coupled output. The video signal average can change greatly depending upon the picture content. With an AC-coupled output, the average will change according to the time constant formed by the series capacitor and series resistance (usually 150 $\Omega$ ). For example, Figure 3 shows an AC-coupled video signal alternating between a completely black screen and a completely white screen. Notice the excursion of the video signal as the screen changes.

With the DirectDrive amplifier, the black level is held at ground. The video signal is constrained between -0.3V to +0.7V. Figure 4 shows the video signal from a DirectDrive amplifier with the same input signal as the AC-coupled system.

### Analog Switch

The MAX9505 features an internal 4.4 $\Omega$  (max) analog normally open switch that interfaces with a 4-pole multimedia jack in which one of the poles can be set to a video input, a video output, or a microphone input. The switch has three modes of operation: open, normal switch, and extended range switch. In normal switch mode, the analog range is from 0V to  $V_{DD}$ . In extended-range switch mode, the analog range is from -2V to  $V_{DD}$ . Logic inputs MODE1 and MODE0 control the analog switch operating modes (Table 1).

### Video Reconstruction Filter

Before the video signal from the DAC can be amplified, it must be lowpass filtered to smooth the steps and to reduce the spikes created whenever the DAC output changes value. In the frequency domain, the steps and spikes cause images of the video signal to appear at multiples of the sampling clock. The MAX9505 contains a six-pole Butterworth lowpass filter. The passband extends to 5.5MHz, and the minimum attenuation is 35dB at 27MHz.

### Operating Modes

The MAX9505 uses two logic inputs to set the device into one of the following modes: 1) shutdown mode, 2) extended-range switch mode, 3) video output mode, and 4) normal switch mode.

In video output mode, the video circuitry is on, the charge pump is on, and the analog switch is open. In normal switch mode, the analog switch is closed, and the video circuitry and charge pump are off. In the extended-range switch mode, the charge pump is on and the analog switch is closed. Shutdown mode reduces the supply current to 10nA typically (see Table 1 and *Typical Application Circuits*).

## DirectDrive Video Amplifier with Reconstruction Filter and Analog Switch

Table 1. Operating Modes

| OPERATING MODE             | MODE1 | MODE0 | VIDEO CIRCUIT | CHARGE PUMP | ANALOG SWITCH | COMMENTS  |
|----------------------------|-------|-------|---------------|-------------|---------------|---|
| Shutdown Mode              | 0     | 0     | Off           | Off         | Open          | Video output is 4k $\Omega$ and analog switch is open                                 |
| Extended Range Switch Mode | 0     | 1     | Off           | On          | Closed        | Video output is high impedance. Analog switch range is from -2V to V <sub>DD</sub> .  |
| Video Output Mode          | 1     | 0     | On            | On          | Open          | Video output is in normal operation. Analog switch is open.                           |
| Normal Switch Mode         | 1     | 1     | Off           | Off         | Closed        | Video output is high impedance. Analog switch range is from SGND to V <sub>DD</sub> . |

### Short-Circuit Protection

The MAX9505 typical operating circuit includes a 75 $\Omega$  back-termination resistor that limits short-circuit current if an external short is applied to the video output. The MAX9505 features internal output, short-circuit protection to prevent device damage in prototyping and applications where the amplifier output can be directly shorted.

### Shutdown

The MAX9505 features a low-power shutdown mode for battery-powered/portable applications. Shutdown reduces the quiescent current to less than 10nA. Setting MODE1 and MODE0 low disables the outputs and places the MAX9505 into a low-power shutdown mode. In shutdown mode the amplifier, charge pump, and linear regulator are turned off and the video output resistance is 4k $\Omega$ .

### Applications Information

#### Power-Supply Bypassing and Ground Management

The MAX9505 operates from a 2.7V to 3.6V single supply and requires proper layout and bypassing. For the best performance, place the components as close to the device as possible.

Proper grounding improves performance and prevents any switching noise from coupling into the video signal. Connect GND and SGND together at a single point on the PC board. Route all traces that carry switching transients away from SGND. Return SGND to the lowest impedance ground available. Route CPGND and all traces carrying switching transients away from SGND, GND, and other traces and components in the video signal path. Bypass the analog supply (V<sub>DD</sub>) with a 1 $\mu$ F capacitor to SGND, placed as close to the device as possible. Bypass the charge-pump supply (CPV<sub>DD</sub>) with a 1 $\mu$ F capacitor to CPGND, placed as close to the device as possible. Connect CPV<sub>SS</sub> to V<sub>SS</sub> and bypass with a 1 $\mu$ F capacitor to CPGND as close to the device as possible.

# DirectDrive Video Amplifier with Reconstruction Filter and Analog Switch

## Pin Configurations

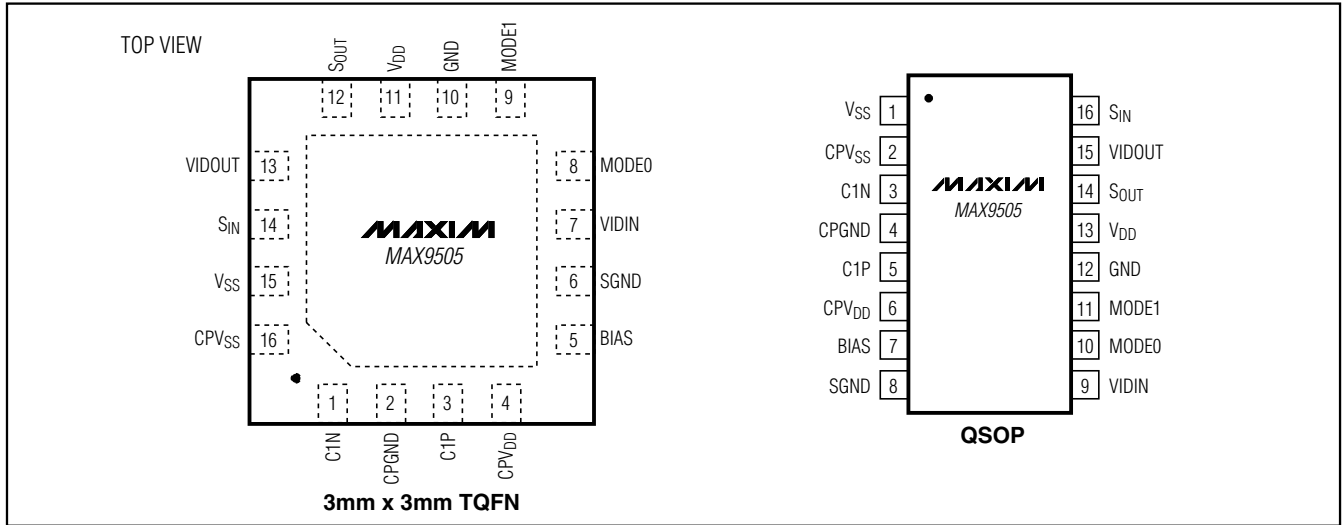

## Functional Diagram/Typical Operating Circuits

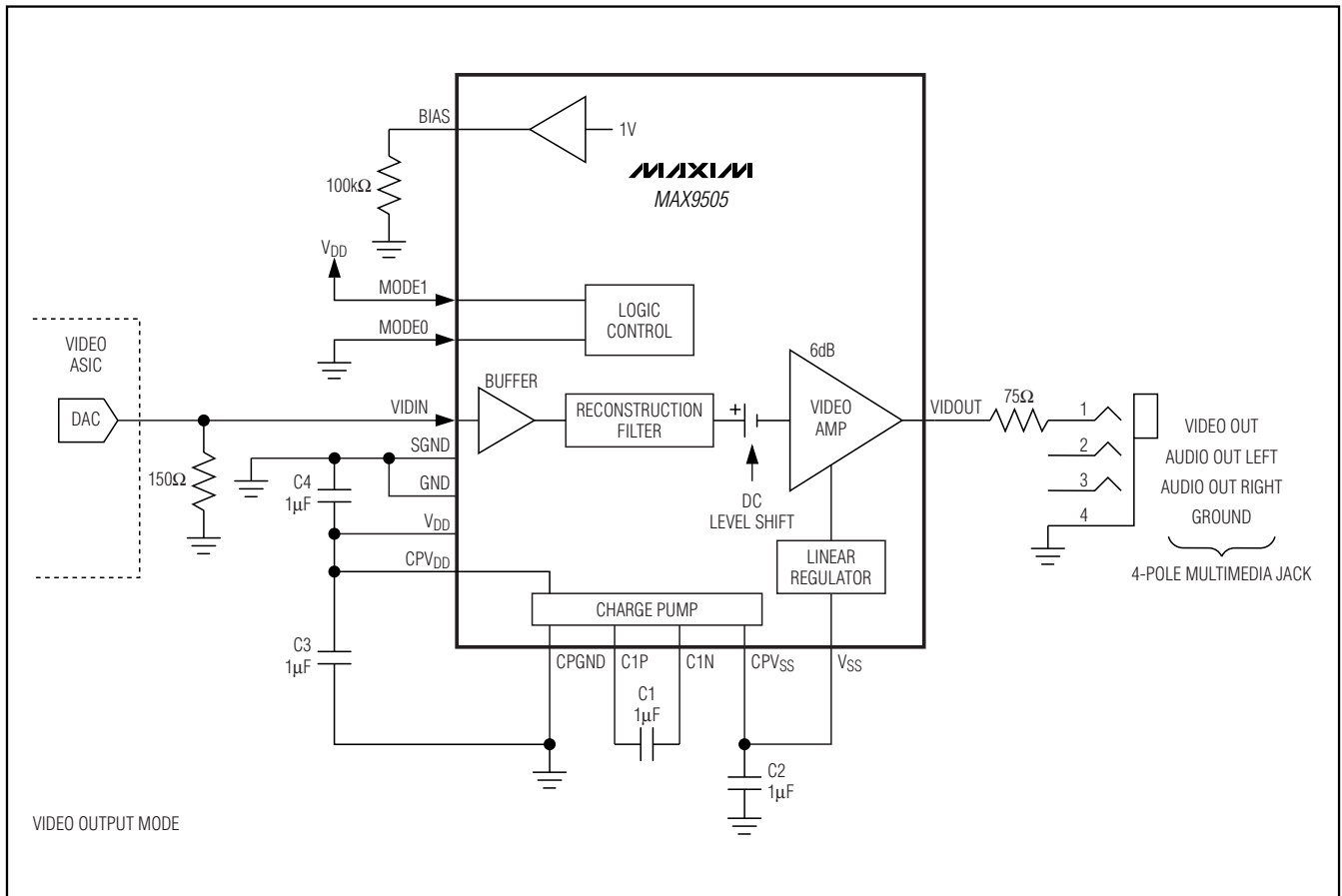

# DirectDrive Video Amplifier with Reconstruction Filter and Analog Switch

## Functional Diagram/Typical Operating Circuits (continued)

MAX9505

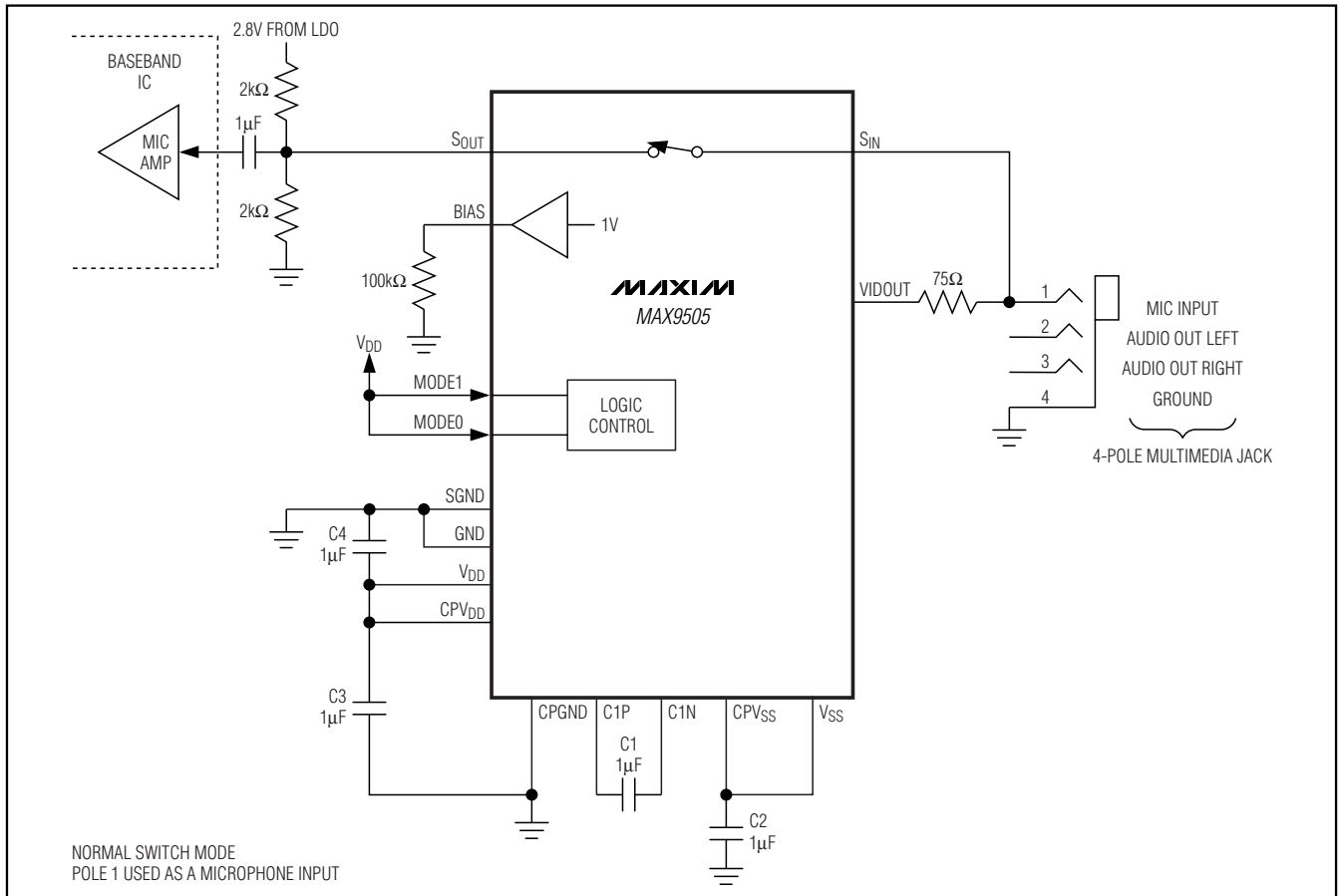

# DirectDrive Video Amplifier with Reconstruction Filter and Analog Switch

## Functional Diagram/Typical Operating Circuits (continued)

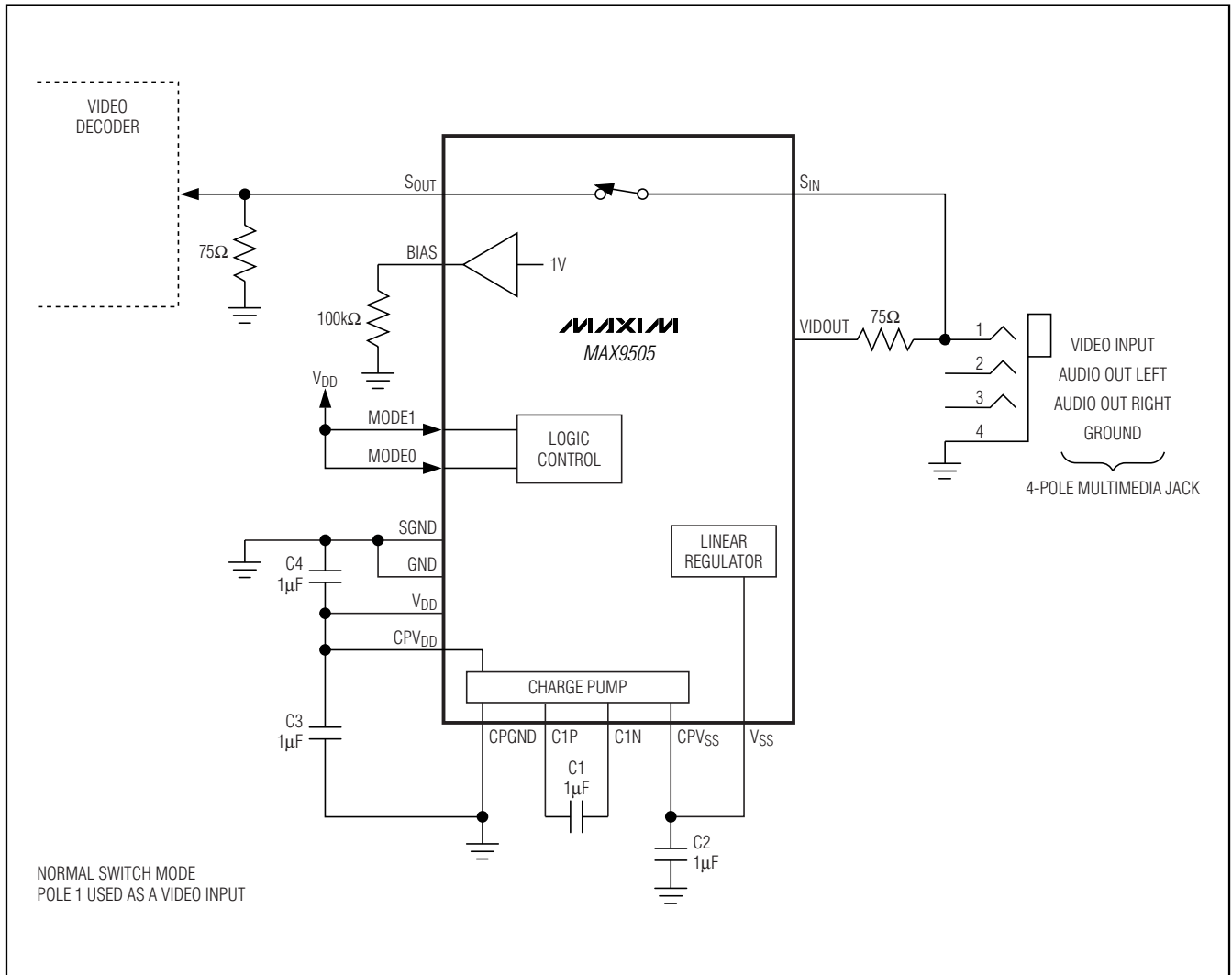

### Chip Information

PROCESS: BICMOS

# DirectDrive Video Amplifier with Reconstruction Filter and Analog Switch

## Package Information

(The package drawing(s) in this data sheet may not reflect the most current specifications. For the latest package outline information, go to [www.maxim-ic.com/packages](http://www.maxim-ic.com/packages).)

MAX9505

| DIM | INCHES         |       | MILLIMETERS |       |
|-----|----------------|-------|-------------|-------|
|     | MIN            | MAX   | MIN         | MAX   |
| A   | .061           | .068  | 1.55        | 1.73  |
| A1  | .004           | .0098 | 0.102       | 0.249 |
| A2  | .055           | .061  | 1.40        | 1.55  |
| B   | .008           | .012  | 0.20        | 0.30  |
| C   | .0075          | .0098 | 0.191       | 0.249 |
| D   | SEE VARIATIONS |       |             |       |
| E   | .150           | .157  | 3.81        | 3.99  |
| e   | .025 BSC       |       | 0.635 BSC   |       |
| H   | .230           | .244  | 5.84        | 6.20  |
| h   | .010           | .016  | 0.25        | 0.41  |
| L   | .016           | .035  | 0.41        | 0.89  |
| N   | SEE VARIATIONS |       |             |       |
| α   | 0°             | 8°    | 0°          | 8°    |

| DIM | INCHES |       | MILLIMETERS |       | N     |
|-----|--------|-------|-------------|-------|-------|
|     | MIN.   | MAX.  | MIN.        | MAX.  |       |
| D   | .189   | .196  | 4.80        | 4.98  | 16 AB |
| S   | .0020  | .0070 | 0.05        | 0.18  |       |
| D   | .337   | .344  | 8.56        | 8.74  | 20 AD |
| S   | .0500  | .0550 | 1.270       | 1.397 |       |
| D   | .337   | .344  | 8.56        | 8.74  | 24 AE |
| S   | .0250  | .0300 | 0.635       | 0.762 |       |
| D   | .386   | .393  | 9.80        | 9.98  | 28 AF |
| S   | .0250  | .0300 | 0.635       | 0.762 |       |

NOTES:

- 1). D & E DO NOT INCLUDE MOLD FLASH OR PROTRUSIONS.
- 2). MOLD FLASH OR PROTRUSIONS NOT TO EXCEED .006" PER SIDE.
- 3). CONTROLLING DIMENSIONS: INCHES.
- 4). MEETS JEDEC MO137.

**DALLAS SEMICONDUCTOR** **MAXIM**

PROPRIETARY INFORMATION

TITLE: PACKAGE OUTLINE, QSOP .150", .025" LEAD PITCH

|          |                                 |               |
|----------|---------------------------------|---------------|
| APPROVAL | DOCUMENT CONTROL NO.<br>21-0055 | REV.<br>E 1/1 |
|----------|---------------------------------|---------------|

# DirectDrive Video Amplifier with Reconstruction Filter and Analog Switch

## Package Information (continued)

(The package drawing(s) in this data sheet may not reflect the most current specifications. For the latest package outline information, go to [www.maxim-ic.com/packages](http://www.maxim-ic.com/packages).)

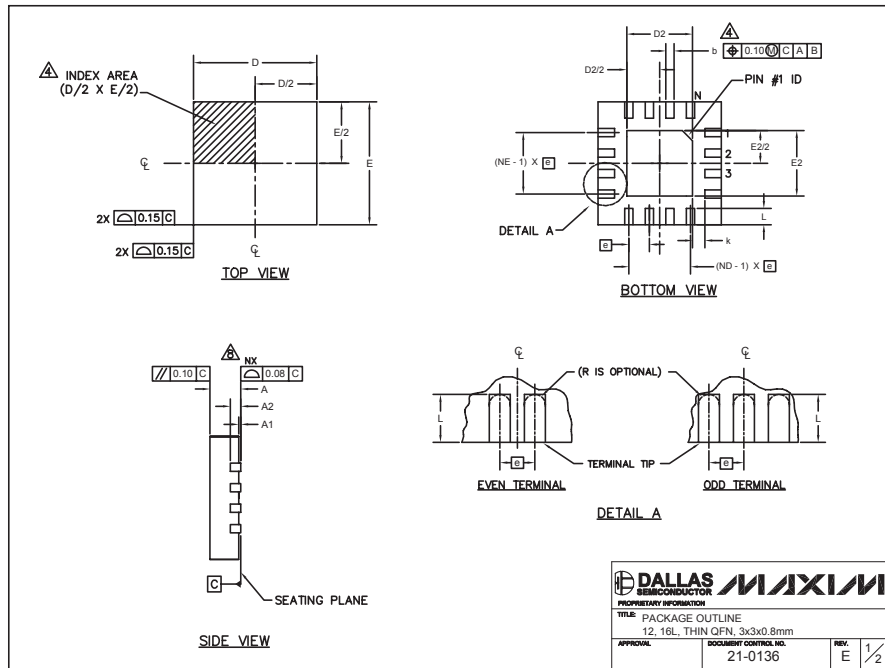

| PKG  | 12L 3x3   |      |      | 16L 3x3   |      |      |
|------|-----------|------|------|-----------|------|------|
| REF. | MIN.      | NOM. | MAX. | MIN.      | NOM. | MAX. |
| A    | 0.70      | 0.75 | 0.80 | 0.70      | 0.75 | 0.80 |
| b    | 0.20      | 0.25 | 0.30 | 0.20      | 0.25 | 0.30 |
| D    | 2.90      | 3.00 | 3.10 | 2.90      | 3.00 | 3.10 |
| E    | 2.90      | 3.00 | 3.10 | 2.90      | 3.00 | 3.10 |
| e    | 0.50 BSC. |      |      | 0.50 BSC. |      |      |
| L    | 0.45      | 0.55 | 0.65 | 0.30      | 0.40 | 0.50 |
| N    | 12        |      |      | 16        |      |      |
| ND   | 3         |      |      | 4         |      |      |
| NE   | 3         |      |      | 4         |      |      |
| A1   | 0         | 0.02 | 0.05 | 0         | 0.02 | 0.05 |
| A2   | 0.20 REF  |      |      | 0.20 REF  |      |      |
| k    | 0.25      | -    | -    | 0.25      | -    | -    |

| PKG CODES | D2   |      |      | E2   |      |      | PIN ID      | JEDEC  | DOWN BONDS ALLOWED |
|-----------|------|------|------|------|------|------|-------------|--------|--------------------|
|           | MIN. | NOM. | MAX. | MIN. | NOM. | MAX. |             |        |                    |
| T1233-1   | 0.95 | 1.10 | 1.25 | 0.95 | 1.10 | 1.25 | 0.35 x 45°  | WEED-1 | NO                 |
| T1233-3   | 0.95 | 1.10 | 1.25 | 0.95 | 1.10 | 1.25 | 0.35 x 45°  | WEED-1 | YES                |
| T1633-1   | 0.95 | 1.10 | 1.25 | 0.95 | 1.10 | 1.25 | 0.35 x 45°  | WEED-2 | NO                 |
| T1633-2   | 0.95 | 1.10 | 1.25 | 0.95 | 1.10 | 1.25 | 0.35 x 45°  | WEED-2 | YES                |
| T1633F-3  | 0.65 | 0.80 | 0.95 | 0.65 | 0.80 | 0.95 | 0.225 x 45° | WEED-2 | N/A                |
| T1633-4   | 0.95 | 1.10 | 1.25 | 0.95 | 1.10 | 1.25 | 0.35 x 45°  | WEED-2 | NO                 |

**NOTES:**

- DIMENSIONING & TOLERANCING CONFORM TO ASME Y14.5M-1994.
- ALL DIMENSIONS ARE IN MILLIMETERS. ANGLES ARE IN DEGREES.
- N IS THE TOTAL NUMBER OF TERMINALS.
- THE TERMINAL #1 IDENTIFIER AND TERMINAL NUMBERING CONVENTION SHALL CONFORM TO JESD 95-1 SPP-012. DETAILS OF TERMINAL #1 IDENTIFIER ARE OPTIONAL, BUT MUST BE LOCATED WITHIN THE ZONE INDICATED. THE TERMINAL #1 IDENTIFIER MAY BE EITHER A MOLD OR MARKED FEATURE.
- DIMENSION b APPLIES TO METALLIZED TERMINAL AND IS MEASURED BETWEEN 0.20 mm AND 0.25 mm FROM TERMINAL TIP.
- ND AND NE REFER TO THE NUMBER OF TERMINALS ON EACH D AND E SIDE RESPECTIVELY.
- DEPOPULATION IS POSSIBLE IN A SYMMETRICAL FASHION.
- COPLANARITY APPLIES TO THE EXPOSED HEAT SINK SLUG AS WELL AS THE TERMINALS.
- DRAWING CONFORMS TO JEDEC MO220 REVISION C.

**DALLAS SEMICONDUCTOR MAXIM**

**PROPRIETARY INFORMATION**

**TITLE** PACKAGE OUTLINE  
12, 16L, THIN QFN, 3x3x0.8mm

**APPROVAL** **DOCUMENT CONTROL NO.** 21-0136 **REV.** E 2/2

Maxim cannot assume responsibility for use of any circuitry other than circuitry entirely embodied in a Maxim product. No circuit patent licenses are implied. Maxim reserves the right to change the circuitry and specifications without notice at any time.