



5V, Low-Power, Voltage-Output, Serial 10-Bit DACs

MAX504/MAX515

General Description

The MAX504/MAX515 are low-power, voltage-output, 10-bit digital-to-analog converters (DACs) specified for single +5V power-supply operation. The MAX504 can also be operated with $\pm 5V$ supplies. The MAX515 draws only 140 μA , and the MAX504 (with internal reference) draws only 260 μA . The MAX515 comes in 8-pin DIP and SO packages, while the MAX504 comes in 14-pin DIP and SO packages. Both parts have been trimmed for offset voltage, gain, and linearity, so no further adjustment is necessary.

The MAX515's buffer is fixed at a gain of 2. The MAX504's internal op amp may be configured for a gain of 1 or 2, as well as for unipolar or bipolar output voltages. The MAX504 can also be used as a four-quadrant multiplier without external resistors or op amps.

For parallel data inputs, see the MAX503 data sheet. For a hardware and software compatible 12-bit upgrade, refer to the MAX531/MAX538/MAX539 data sheet.

Applications

- Battery-Powered Test Instruments
- Digital Offset and Gain Adjustment
- Battery-Operated/Remote Industrial Controls
- Machine and Motion Control Devices
- Cellular Telephones

Functional Diagram

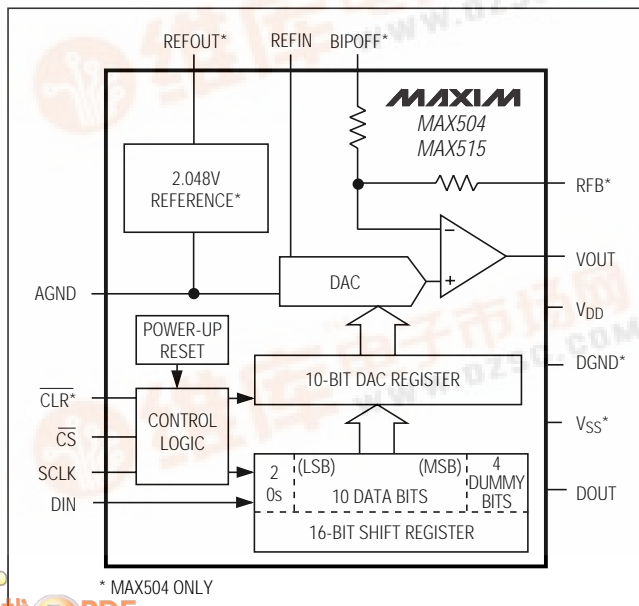

Features

- ◆ Operate from Single +5V Supply
- ◆ Buffered Voltage Output
- ◆ Internal 2.048V Reference (MAX504)
- ◆ 140 μA Supply Current (MAX515)
- ◆ INL = $\pm 1/2$ LSB (max)
- ◆ Guaranteed Monotonic Over Temperature
- ◆ Flexible Output Ranges:
0V to V_{DD} (MAX504/MAX515)
 V_{SS} to V_{DD} (MAX504)
- ◆ 8-Pin SO/DIP (MAX515)
- ◆ Power-On Reset
- ◆ Serial Data Output for Daisy-Chaining

Ordering Information

PART	TEMP. RANGE	PIN-PACKAGE
MAX504CPD	0°C to +70°C	14 Plastic DIP
MAX504CSD	0°C to +70°C	14 SO
MAX504EPD	-40°C to +85°C	14 Plastic DIP
MAX504ESD	-40°C to +85°C	14 SO
MAX515CPA	0°C to +70°C	8 Plastic DIP
MAX515CSA	0°C to +70°C	8 SO
MAX515EPA	-40°C to +85°C	8 Plastic DIP
MAX515ESA	-40°C to +85°C	8 SO

Refer to the MAX531/MAX538/MAX539 data sheet for military temperature or die equivalents.

Pin Configurations

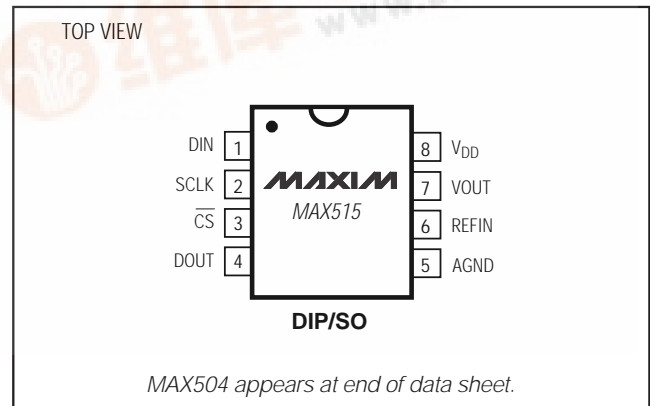

5V, Low-Power, Voltage-Output Serial 10-Bit DACs

ABSOLUTE MAXIMUM RATINGS

V _{DD} to DGND and V _{DD} to AGND	-0.3V, +6V
V _{SS} to DGND and V _{SS} to AGND	-6V, +0.3V
V _{DD} to V _{SS}	-0.3V, +12V
AGND to DGND	-0.3V, +0.3V
Digital Input Voltage to DGND	-0.3V, (V _{DD} + 0.3V)
REFIN	(V _{SS} - 0.3V), (V _{DD} + 0.3V)
REFOUT to AGND	-0.3V, (V _{DD} + 0.3V)
RFB	(V _{SS} - 0.3V), (V _{DD} + 0.3V)
BIPOFF	(V _{SS} - 0.3V), (V _{DD} + 0.3V)
V _{OUT} (Note 1)	V _{SS} , V _{DD}
Continuous Current, Any Pin	-20mA, +20mA

Continuous Power Dissipation (T_A = +70°C)

8-Pin Plastic DIP (derate 9.09mW/°C above +70°C)	727mW
8-Pin SO (derate 5.88mW/°C above +70°C)	471mW
14-Pin Plastic DIP (derate 10.00mW/°C above +70°C)	800mW
14-Pin SO (derate 8.33mW/°C above +70°C)	667mW

Operating Temperature Ranges

MAX5_C_	0°C to +70°C
MAX5_E_	-40°C to +85°C
Storage Temperature Range	-65°C to +165°C
Lead Temperature (soldering, 10sec)	+300°C

Note 1: The output may be shorted to V_{DD}, V_{SS}, or AGND if the package power dissipation limit is not exceeded.

Stresses beyond those listed under "Absolute Maximum Ratings" may cause permanent damage to the device. These are stress ratings only, and functional operation of the device at these or any other conditions beyond those indicated in the operational sections of the specifications is not implied. Exposure to absolute maximum rating conditions for extended periods may affect device reliability.

ELECTRICAL CHARACTERISTICS—Single +5V Supply

(V_{DD} = 5V, V_{SS} = 0V, AGND = DGND = 0V, REFIN = 2.048V (external), RFB = BIPOFF = V_{OUT} (MAX504), C_{REFOUT} = 33μF (MAX504), R_L = 10kΩ, C_L = 100pF, T_A = T_{MIN} to T_{MAX}, unless otherwise noted.)

PARAMETER	SYMBOL	CONDITIONS	MIN	TYP	MAX	UNITS
STATIC PERFORMANCE						
Resolution	N		10			Bits
Relative Accuracy (Note 2)	INL				±0.5	LSB
Differential Nonlinearity	DNL	Guaranteed monotonic			±1	LSB
Unipolar Offset Error	V _{OS}		0		3	LSB
Unipolar Offset Tempco	TCV _{OS}			3		ppm/°C
Unipolar Offset-Error Power-Supply Rejection Ratio	PSRR	4.5V ≤ V _{DD} ≤ 5.5V		0.1		LSB/V
Gain Error (Note 2)	GE				±1	LSB
Gain-Error Tempco				1		ppm/°C
Gain-Error Power-Supply Rejection Ratio	PSRR	4.5V ≤ V _{DD} ≤ 5.5V		0.1		LSB/V
VOLTAGE OUTPUT (V_{OUT})						
Output Voltage Range		MAX504 (G = 1)	0		V _{DD} - 2	V
		MAX504 (G = 2), MAX515	0		V _{DD} - 0.4	
Output Load Regulation		V _{OUT} = 2V, R _L = 2kΩ			0.5	LSB
Short-Circuit Current	I _{SC}			12		mA
REFERENCE INPUT (REFIN)						
Voltage Range			0		V _{DD} - 2	V
Input Resistance		Code dependent, minimum at code 0101...	40			kΩ
Input Capacitance		Code dependent (Note 3)	10		50	pF
AC Feedthrough		REFIN = 1kHz, 2Vp-p		-80		dB

5V, Low-Power, Voltage-Output, Serial 10-Bit DACs

MAX504/MAX515

ELECTRICAL CHARACTERISTICS—Single +5V Supply (continued)

($V_{DD} = 5V$, $V_{SS} = 0V$, $AGND = DGND = 0V$, $REFIN = 2.048V$ (external), $RFB = BIPOFF = VOUT$ (MAX504), $C_{REFOUT} = 33\mu F$ (MAX504), $R_L = 10k\Omega$, $C_L = 100pF$, $T_A = T_{MIN}$ to T_{MAX} , unless otherwise noted.)

PARAMETER	SYMBOL	CONDITIONS	MIN	TYP	MAX	UNITS
REFERENCE OUTPUT (REFOUT—MAX504 Only)						
Reference Output Voltage		$T_A = +25^\circ C$	2.024	2.048	2.072	V
		MAX504C	2.015		2.081	
		MAX504E	2.011		2.085	
Temperature Coefficient	TC_{REFOUT}			30		ppm/ $^\circ C$
Resistance	R_{REFOUT}	(Note 4)		0.5	2	Ω
Power-Supply Rejection Ratio	PSRR	$4.5V \leq V_{DD} \leq 5.5V$		200		$\mu V/V$
Noise Voltage	e_n	0.1Hz to 10kHz		400		μV_{p-p}
Required External Capacitor	C_{REFOUT}		3.3			μF
DIGITAL INPUTS (DIN, SCLK, CS, CLR)						
Input High	V_{IH}		2.4			V
Input Low	V_{IL}				0.8	V
Input Current	I_{IN}	$V_{IN} = 0V$ or V_{DD}			± 1	μA
Input Capacitance	C_{IN}			8		pF
DIGITAL OUTPUT (DOUT)						
Output High	V_{OH}	$I_{SOURCE} = 2mA$	$V_{DD} - 1$			V
Output Low	V_{OL}	$I_{SINK} = 2mA$			0.4	V
DYNAMIC PERFORMANCE						
Voltage-Output Slew Rate	SR	$T_A = +25^\circ C$	0.15	0.25		V/ μs
Voltage-Output Settling Time		$T_o \pm 1/2LSB$, $V_{OUT} = 2V$		25		μs
Digital Feedthrough		$\overline{CS} = V_{DD}$, $DIN = 100kHz$		5		nV-s
Signal-to-Noise Plus Distortion	SINAD	$REFIN = 1kHz$, $2V_{p-p}$ ($G = 1$ or 2), code = 1111...		68		dB
POWER SUPPLY						
Positive Supply Voltage	V_{DD}		4.5		5.5	V
Power-Supply Current	I_{DD}	All inputs = $0V$ or V_{DD} , output = no load	MAX504	260	400	μA
			MAX515	140	300	
SWITCHING CHARACTERISTICS (Note 5)						
\overline{CS} Setup Time	t_{CSS}		20			ns
SCLK Fall to \overline{CS} Fall Hold Time	t_{CSH0}		15			ns
SCLK Fall to \overline{CS} Rise Hold Time	t_{CSH1}		0			ns
SCLK High Width	t_{CH}		35			ns
SCLK Low Width	t_{CL}		35			ns
DIN Setup Time	t_{DS}		45			ns
DIN Hold Time	t_{DH}		0			ns
DOUT Valid Propagation Delay	t_{DO}	$C_L = 50pF$			80	ns
\overline{CS} High Pulse Width	t_{CSW}		20			ns
\overline{CLR} Pulse Width	t_{CLR}		25			ns
\overline{CS} Rise to SCLK Rise Setup Time	t_{CS1}		50			ns

5V, Low-Power, Voltage-Output, Serial 10-Bit DACs

ELECTRICAL CHARACTERISTICS—Dual $\pm 5V$ Supplies (MAX504 Only)

($V_{DD} = 5V$, $V_{SS} = -5V$, $AGND = DGND = 0V$, $REFIN = 2.048V$ (external), $R_{FB} = BIPOFF = V_{OUT}$, $C_{REFOUT} = 33\mu F$, $R_L = 10k\Omega$, $C_L = 100pF$, $T_A = T_{MIN}$ to T_{MAX} , unless otherwise noted.)

PARAMETER	SYMBOL	CONDITIONS	MIN	TYP	MAX	UNITS
Resolution	N		10			Bits
Relative Accuracy	INL				± 0.5	LSB
Differential Nonlinearity	DNL	Guaranteed monotonic			± 1	LSB
Bipolar Offset Error	V_{OS}	$BIPOFF = REFIN$			± 3	LSB
Bipolar Offset Tempco	TCV_{OS}	$BIPOFF = REFIN$		3		ppm/ $^{\circ}C$
Offset-Error Power-Supply Rejection Ratio	PSRR	$4.5V \leq V_{DD} \leq 5.5V$, $-5.5V \leq V_{SS} \leq -4.5V$		0.1		LSB/V
Gain Error (Unipolar or Bipolar)	GE				± 1	LSB
Gain-Error Tempco				1		ppm/ $^{\circ}C$
Gain-Error Power-Supply Rejection Ratio	PSRR	$4.5V \leq V_{DD} \leq 5.5V$, $-5.5V \leq V_{SS} \leq -4.5V$		0.1		LSB/V
REFERENCE INPUT (REFIN)						
Voltage Range			$V_{SS} + 2$		$V_{DD} - 2$	V
Input Resistance		Code dependent, minimum at code 0101...	40			k Ω
Input Capacitance		Code dependent (Note 3)	10		50	pF
AC Feedthrough		$REFIN = 1kHz$, $2.0V_{p-p}$		-80		dB
REFERENCE OUTPUT (REFOUT—MAX504 Only)						
Reference Output Voltage		$T_A = +25^{\circ}C$	2.024	2.048	2.072	V
		MAX504C	2.015		2.081	
		MAX504E	2.011		2.085	
Temperature Coefficient	TC_{REFOUT}			30		ppm/ $^{\circ}C$
Resistance	R_{REFOUT}	(Note 4)		0.5	2	Ω
Power-Supply Rejection Ratio	PSRR	$4.5V \leq V_{DD} \leq 5.5V$		200		$\mu V/V$
Noise Voltage	e_n	0.1Hz to 10kHz		400		μV_{p-p}
Required External Capacitor	C_{REFOUT}		3.3			μF
DIGITAL INPUTS (DIN, SCLK, CS)						
Input High	V_{IH}		2.4			V
Input Low	V_{IL}				0.8	V
Input Current	I_{IN}	$V_{IN} = 0V$ or V_{DD}			± 1	μA
Input Capacitance	C_{IN}			8		pF
DIGITAL OUTPUT (DOUT)						
Output High	V_{OH}	$I_{SOURCE} = 2mA$	$V_{DD} - 1$			V
Output Low	V_{OL}	$I_{SINK} = 2mA$			0.4	V

5V, Low-Power, Voltage-Output, Serial 10-Bit DACs

MAX504/MAX515

ELECTRICAL CHARACTERISTICS—Dual ±5V Supplies (MAX504 Only) (continued)

($V_{DD} = 5V$, $V_{SS} = -5V$, $AGND = DGND = 0V$, $REFIN = 2.048V$ (external), $RFB = BIPOFF = VOUT$, $C_{REFOUT} = 33\mu F$, $R_L = 10k\Omega$, $C_L = 100pF$, $T_A = T_{MIN}$ to T_{MAX} , unless otherwise noted.)

PARAMETER	SYMBOL	CONDITIONS	MIN	TYP	MAX	UNITS
VOLTAGE OUTPUT (VOUT)						
Output Voltage Range		(G = 1)	$V_{SS} + 2$		$V_{DD} - 2$	V
		(G = 2)	$V_{SS} + 0.4$		$V_{DD} - 0.4$	
Output Load Regulation		$VOUT = 2V$, $R_L = 2k\Omega$			0.5	LSB
Short-Circuit Current	I_{SC}			12		mA
DYNAMIC PERFORMANCE						
Voltage-Output Slew Rate	SR		0.15	0.25		V/ μs
Voltage-Output Settling Time		$T_o \pm 1/2LSB$, $VOUT = 2V$		16		μs
Digital Feedthrough		Step all 0s to all 1s		5		nV-s
Signal-to-Noise Plus Distortion	SINAD	$REFIN = 1kHz$, $2Vp-p$ (G = 1)		68		dB
		$REFIN = 1kHz$, $2Vp-p$ (G = 2)		68		
POWER SUPPLY						
Positive Supply Voltage	V_{DD}		4.5		5.5	V
Negative Supply Voltage	V_{SS}		-5.5		0	V
Positive Supply Current	I_{DD}	All inputs = 0V or V_{DD} , no load		260	400	μA
Negative Supply Current	I_{SS}	All inputs = 0V or V_{DD} , no load		-120	-200	μA
SWITCHING CHARACTERISTICS						
\overline{CS} Setup Time	t_{CSS}		20			ns
SCLK Fall to \overline{CS} Fall Hold Time	t_{CSH0}		15			ns
SCLK Fall to \overline{CS} Rise Hold Time	t_{CSH1}		0			ns
SCLK High Width	t_{CH}		35			ns
SCLK Low Width	t_{CL}		35			ns
DIN Setup Time	t_{DS}		45			ns
DIN Hold Time	t_{DH}		0			ns
DOUT Valid Propagation Delay	t_{DO}	$C_L = 50pF$			80	ns
\overline{CS} High Pulse Width	t_{CSW}		20			ns
\overline{CLR} Pulse Width	t_{CLR}		25			ns
\overline{CS} Rise to SCLK Rise Setup Time	t_{CS1}		50			ns

Note 2: In single-supply operation, INL and GE calculated from Code 3 to Code 1023.

Note 3: Guaranteed by design.

Note 4: Tested at $I_{OUT} = 100\mu A$. The reference can typically source up to 5mA (see *Typical Operating Characteristics*).

Note 5: The timing characteristics limits for the MAX515 are guaranteed by design.

5V, Low-Power, Voltage-Output, Serial 10-Bit DACs

Typical Operating Characteristics

($V_{DD} = +5V$, $V_{REFIN} = 2.048V$, $T_A = +25^\circ C$, unless otherwise noted.)

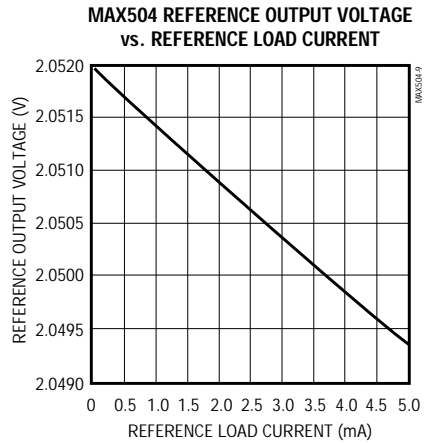
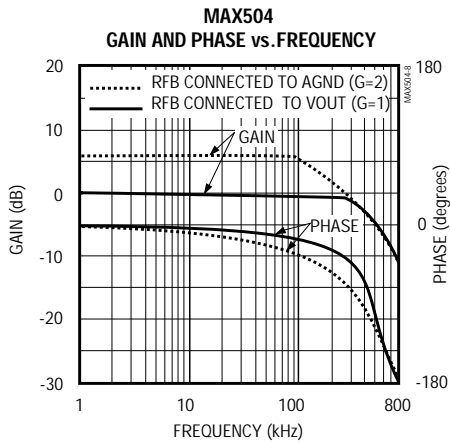
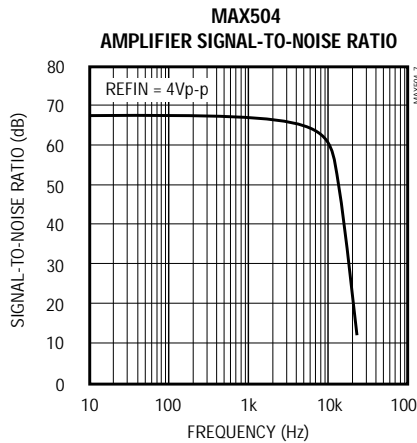
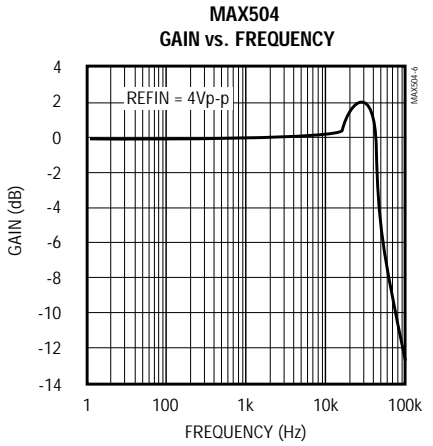
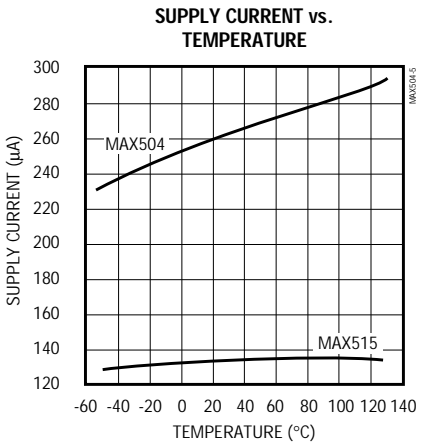
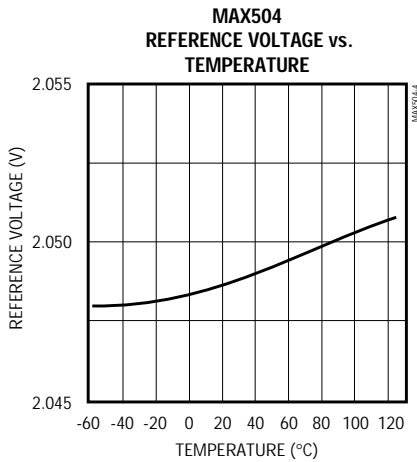
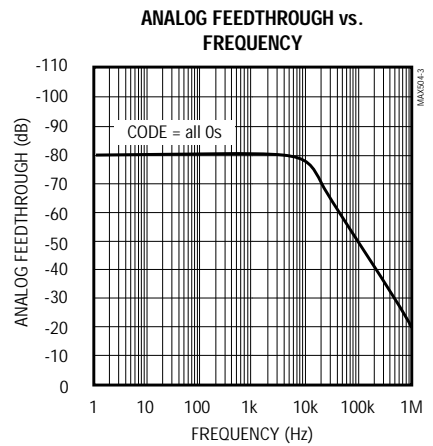
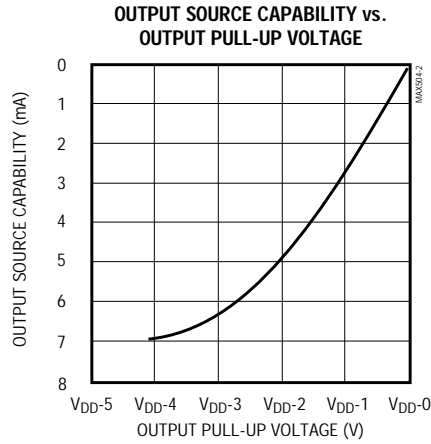
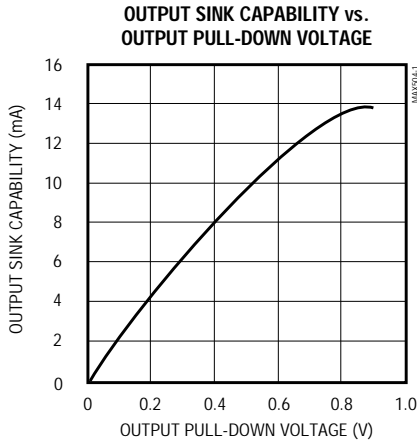

5V, Low-Power, Voltage-Output, Serial 10-Bit DACs

MAX504/MAX515

Typical Operating Characteristics (continued)

(VDD = +5V, VREFIN = 2.048V, TA = +25°C, unless otherwise noted.)

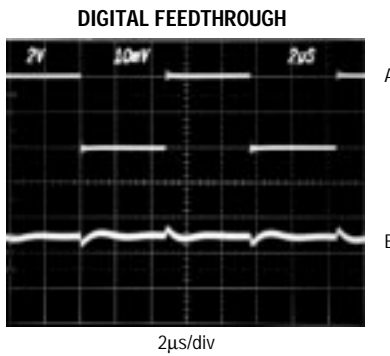

\overline{CS} = HIGH
 A: DIN = 4Vp-p, 100kHz
 B: VOUT, 10mV/div

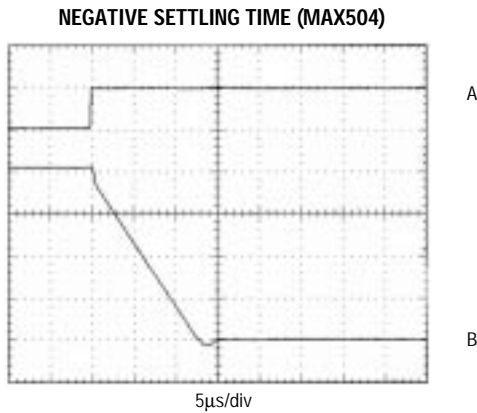

A: \overline{CS} RISING EDGE, 5V/div
 B: VOUT, NO LOAD, 1V/div
 DUAL SUPPLY $\pm 5V$
 BIPOLAR CONFIGURATION
 VREFIN = 2V

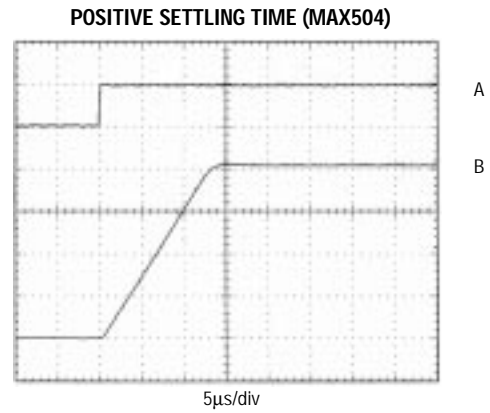

A: \overline{CS} RISING EDGE, 5V/div
 B: VOUT, NO LOAD, 1V/div
 DUAL SUPPLY $\pm 5V$
 BIPOLAR CONFIGURATION
 VREFIN = 2V

5V, Low-Power, Voltage-Output Serial 10-Bit DACs

Pin Description

PIN		NAME	FUNCTION
MAX504	MAX515		
1	—	BIPOFF	Bipolar offset/gain resistor
2	1	DIN	Serial data input
3	—	$\overline{\text{CLR}}$	Clear. Asynchronously sets DAC register to all 0s.
4	2	SCLK	Serial clock input
5	3	$\overline{\text{CS}}$	Chip select, active low
6	4	DOUT	Serial data output for daisy-chaining
7	—	DGND	Digital ground
8	5	AGND	Analog ground
9	6	REFIN	Reference input
10	—	REFOUT	Reference output, 2.048V. Connect to V_{DD} if not used.
11	—	VSS	Negative power supply
12	7	VOUT	DAC output
13	8	V_{DD}	Positive power supply
14	—	RFB	Feedback resistor

Detailed Description

General DAC Discussion

The MAX504/MAX515 use an “inverted” R-2R ladder network with a single-supply CMOS op amp to convert 10-bit digital data to analog voltage levels (see *Functional Diagram*). The term “inverted” describes the ladder network because the REFIN pin in current-output DACs is the summing junction, or virtual ground, of an op amp. However, such use would result in the output voltage being the inverse of the reference voltage. The MAX504/MAX515's topology makes the output the same polarity as the reference input.

An internal reset circuit forces the DAC register to reset to all 0s on power-up. Additionally, a clear ($\overline{\text{CLR}}$) pin, when held low, sets the DAC register to all 0s. $\overline{\text{CLR}}$ operates asynchronously and independently from the chip select ($\overline{\text{CS}}$) pin.

Buffer Amplifier

The output buffer is a unity-gain stable, rail-to-rail output, BiCMOS op amp. Input offset voltage and CMRR are trimmed to achieve better than 10-bit performance. Settling time is 25 μ s to 0.01% of final value. The output is short-circuit protected and can drive a 2k Ω load with more than 100pF load capacitance.

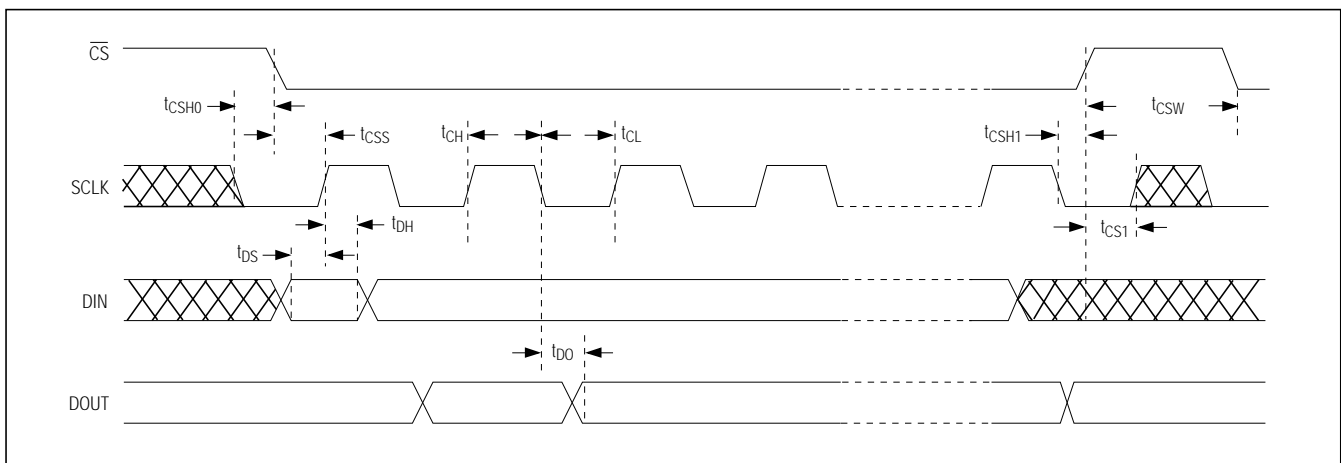

Figure 1. Timing Diagram

5V, Low-Power, Voltage-Output, Serial 10-Bit DACs

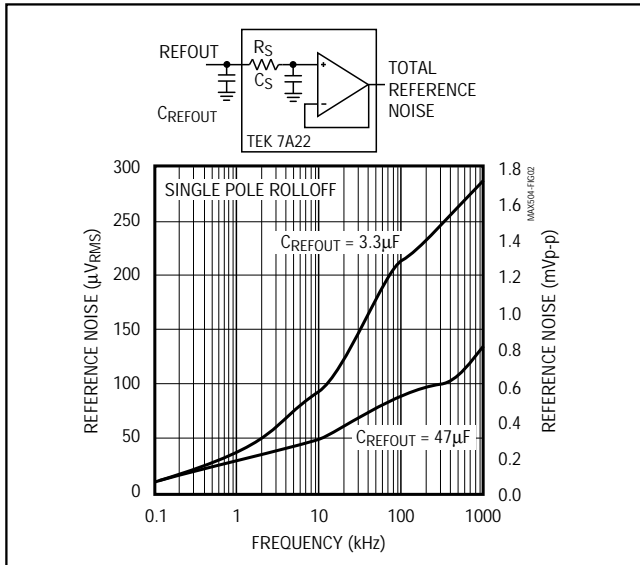

Figure 2. Reference Noise vs. Frequency

Internal Reference (MAX504 only)

The on-chip reference is laser trimmed to generate 2.048V at REFOUT. The output stage can source and sink current so REFOUT can settle to the correct voltage quickly in response to code-dependent loading changes. Typically, source current is 5mA and sink current is 100µA.

REFOUT connects the internal reference to the R-2R DAC ladder at REFIN. The R-2R ladder draws 50µA maximum load current. If any other connection is made to REFOUT, ensure that the total load current is less than 100µA to avoid gain errors.

For applications requiring very low-noise performance, connect a 33µF capacitor from REFOUT to AGND. If noise is not a concern, a lower value (3.3µF min) capacitor may be used. To reduce noise further, insert a buffered RC filter between REFOUT and REFIN (Figure 2). The reference bypass capacitor CREFOUT is still required for reference stability. In applications not requiring the reference, connect REFOUT to VDD (to save power and to eliminate the need for CREFOUT) or use the MAX515 (no internal reference).

External Reference

An external reference in the range (VSS + 2V) to (VDD - 2V) may be used with the MAX504 in dual-supply operation. With the MAX515 or the MAX504 in single-supply use, the reference must be positive and may not exceed VDD - 2V. The reference voltage determines the DAC's full-scale output. The DAC input resistance is code dependent and is minimum (40kΩ) at code 0101... and virtually infinite at

code 0000.... REFIN's input capacitance is also code dependent and has a 50pF maximum value at several codes.

If an upgrade to the internal reference is required, the 2.5V MAX873A is suitable: ±15mV initial accuracy, TCVOUT = 7ppm/°C (max).

Logic Interface

The MAX504/MAX515 logic inputs are designed to be compatible with TTL or CMOS logic levels. However, to achieve the lowest power dissipation, drive the digital inputs with rail-to-rail CMOS logic. With TTL logic levels, the power requirement increases by a factor of approximately 2.

Serial Clock and Update Rate

Figure 1 shows the MAX504/MAX515 timing. The maximum serial clock rate is given by 1/(tCH+tCL), approximately 14MHz. The digital update rate is limited by the chip-select period, which is 16 x (tCH + tCL) + tCSW. This equals a 1.14µs, or 877kHz, update rate. However, the DAC settling time to 10 bits is 25µs, which may limit the update rate to 40kHz for full-scale step transitions.

Applications Information

Refer to Figures 3a and 3b for typical operating connections.

Serial Interface

The MAX504/MAX515 use a three-wire serial interface that is compatible with SPI™, QSPI™ (CPOL = CPHA = 0), and Microwire™ standards as shown in Figures 4 and 5. The DAC is programmed by writing two 8-bit words (see Figure 1 and the *Functional Diagram*). 16 bits of serial data are clocked into the DAC in the following order: 4 fill (dummy) bits, 10 data bits, and 2 sub-LSB 0s. The 4 dummy bits are not normally needed, and are required **only** when DACs are daisy chained. The 2 sub-LSB 0s, however, are **always** needed, and allow hardware and software compatibility with the 12-bit MAX531/MAX538/MAX539. Transitions at \overline{CS} should occur while SCLK is low. Data is clocked in on SCLK's rising edge while \overline{CS} is low. The serial input data is held in a 16-bit serial shift register. On \overline{CS} 's rising edge, the 10 data-bits are transferred to the DAC register and update the DAC. With \overline{CS} high, data cannot be clocked into the MAX504/MAX514.

The MAX504/MAX515 inputs data in 16-bit blocks. The SPI and Microwire interfaces output data in 8-bit blocks, thereby requiring two write cycles to input data to the DAC. The QSPI interface allows variable data input from 8 to 16 bits, and can be loaded into the DAC in one write cycle.

SPI and QSPI are trademarks of Motorola, Inc. Microwire is a trademark of National Semiconductor Corp.

5V, Low-Power, Voltage-Output, Serial 10-Bit DACs

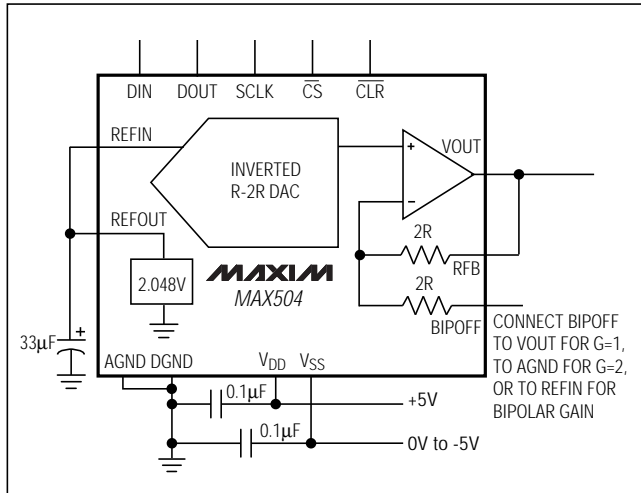

Figure 3a. MAX504 Typical Operating Circuit

Daisy-Chaining Devices

The serial output, DOUT, allows cascading of two or more DACs. The data at DIN appears at DOUT, delayed by 16 clock cycles plus one clock width. For low power, DOUT is a CMOS output that does not require an external pull-up resistor. DOUT does **not** go into a high-impedance state when \overline{CS} is high. DOUT changes on SCLK's falling edge when \overline{CS} is low. When \overline{CS} is high, DOUT remains in the state of the last data bit.

Any number of MAX504/MAX515 DACs can be daisy-chained by connecting the DOUT of one device to the DIN of the next device in the chain. For proper timing, ensure that t_{CL} (SCLK low) is greater than $t_{DO} + t_{DS}$.

Unipolar Configuration

The MAX504 is configured for a gain of 1 (0V to V_{REFIN} unipolar output) by connecting BIPOFF and RFB to VOUT (Figure 6). The converter operates from either single or dual supplies in this configuration. See Table 1 for the DAC-latch contents (input) vs. the analog VOUT (output). In this range, $1LSB = V_{REFIN} (2^{-10})$, where V_{REF} is the voltage on REFIN.

A gain of 2 (0V to $2V_{REFIN}$ unipolar output) is set up by connecting BIPOFF to AGND and RFB to VOUT (Figure 7). Table 2 shows the DAC-latch contents vs. VOUT. The MAX504 operates from either single or dual supplies in this mode. In this range,

$$1LSB = (2)(V_{REFIN})(2^{-10}) = (V_{REFIN})(2^{-9}).$$

The MAX515 is internally configured for unipolar gain of 2 operation.

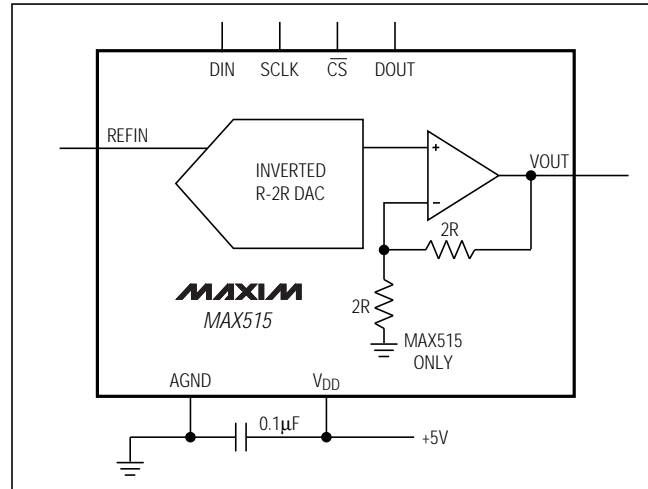

Figure 3b. MAX515 Typical Operating Circuit

Bipolar Configuration

A bipolar range is set up by connecting BIPOFF to REFOUT and RFB to VOUT, and operating from dual ($\pm 5V$) supplies (Figure 8). Table 3 shows the DAC-latch contents (input) vs. VOUT (output). In this range, $1LSB = V_{REFIN} (2^{-9})$.

Four-Quadrant Multiplication

The MAX504 can be used as a four-quadrant multiplier by connecting BIPOFF to REFOUT and RFB to VOUT, and using (1) an offset binary digital code, (2) bipolar power supplies, and (3) a bipolar analog input at REFOUT within the range $V_{SS} + 2V$ to $V_{DD} - 2V$, as shown in Figure 9.

In general, a 10-bit DAC's output is $(D)(V_{REFIN})(G)$, where "G" is the gain (1 or 2) and "D" is the binary representation of the digital input divided by 2^{10} or 1,024. This formula is precise for unipolar operation. However, for bipolar, offset binary operation, the MSB is really a polarity bit. No resolution is lost because the number of steps is the same. The output voltage, however, has been shifted from a range of, for example, 0V to 4.096V ($G = 2$) to a range of -2.048V to +2.048V.

Keep in mind that when using the DAC as a four-quadrant multiplier, the scale is skewed. Negative full scale is $-V_{REFIN}$, while positive full scale is $+V_{REFIN} - 1LSB$.

5V, Low-Power, Voltage-Output, Serial 10-Bit DACs

MAX504/MAX515

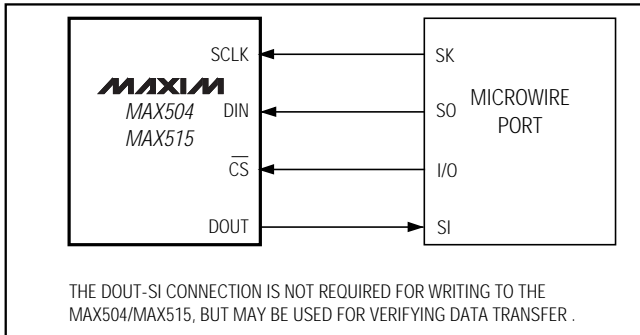

Figure 4. Microwire Connection

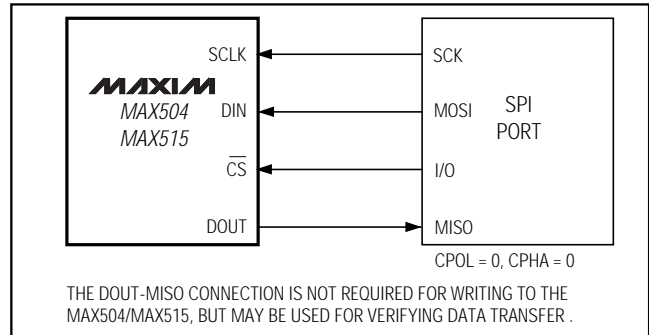

Figure 5. SPI/QSPI Connection

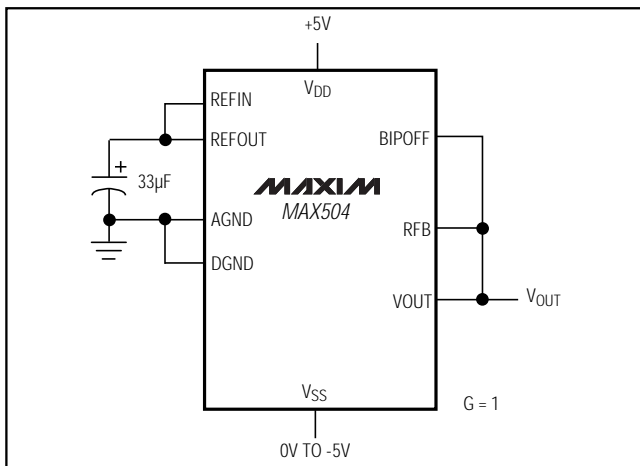

Figure 6. Unipolar Configuration (0V to +2.048V Output)

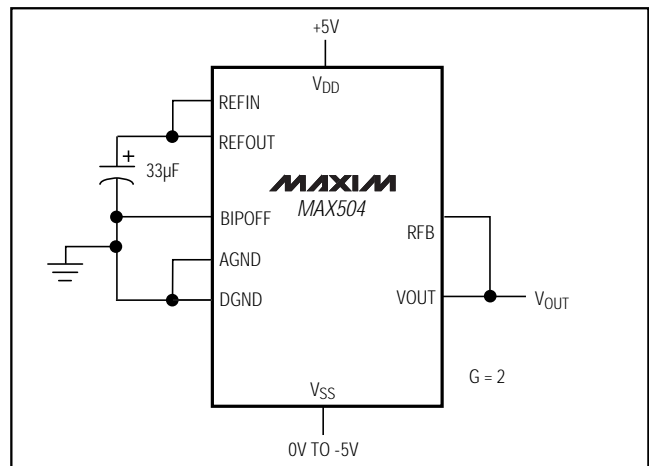

Figure 7. Unipolar Configuration (0V to +4.096V Output)

Table 1. Unipolar Binary Code Table (0V to VREFIN Output), Gain = 1

INPUT*	OUTPUT
1111 1111 11(00)	$(V_{REFIN}) \frac{1023}{1024}$
1000 0000 01(00)	$(V_{REFIN}) \frac{513}{1024}$
1000 0000 00(00)	$(V_{REFIN}) \frac{512}{1024} = +V_{REFIN}/2$
0111 1111 11(00)	$(V_{REFIN}) \frac{511}{1024}$
0000 0000 01(00)	$(V_{REFIN}) \frac{1}{1024}$
0000 0000 00(00)	0V

* Write 10-bit data words with two sub-LSB 0s because the DAC input latch is 12 bits wide.

Table 2. Unipolar Binary Code Table (0V to 2VREFIN Output), Gain = 2

INPUT*	OUTPUT
1111 1111 11(00)	$+2 (V_{REFIN}) \frac{1023}{1024}$
1000 0000 01(00)	$+2 (V_{REFIN}) \frac{513}{1024}$
1000 0000 00(00)	$+2 (V_{REFIN}) \frac{512}{1024} = +V_{REFIN}$
0111 1111 11(00)	$+2 (V_{REFIN}) \frac{511}{1024}$
0000 0000 01(00)	$+2 (V_{REFIN}) \frac{1}{1024}$
0000 0000 00(00)	0V

* Write 10-bit data words with two sub-LSB 0s because the DAC input latch is 12 bits wide.

5V, Low-Power, Voltage-Output, Serial 10-Bit DACs

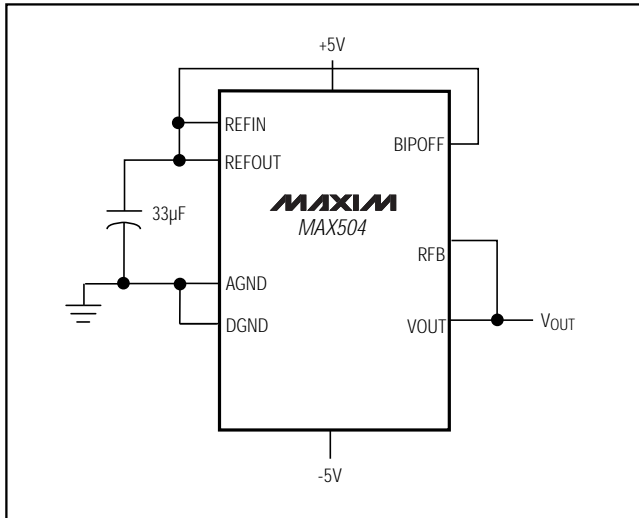

Figure 8. Bipolar Configuration (-2.048V to +2.048V Output)

Single-Supply Linearity

As with any amplifier, the MAX504/MAX515's output buffer offset can be positive or negative. When the offset is positive, it is easily accounted for (Figure 10). However, when the offset is negative, the buffer output cannot follow linearly when there is no negative supply. In that case, the amplifier output (VOUT) remains at ground until the DAC voltage is sufficient to overcome the offset and the output becomes positive.

Normally, linearity is measured after accounting for zero error and gain error. Since, in single-supply operation, the actual value of a negative offset is unknown, it cannot be accounted for during test. Additionally, the output buffer amplifier exhibits a nonlinearity near-zero output when operating with a single supply. To account for this nonlinearity in the MAX504/MAX515, linearity and gain error are measured from code 3 to code 1023. The output buffer's offset and nonlinearity do not affect monotonicity, and these DACs are guaranteed monotonic starting with code zero. In dual-supply operation, linearity and gain error are measured from code 0 to 1023.

Power-Supply Bypassing and Ground Management

Best system performance is obtained with printed circuit boards that use separate analog and digital ground planes. Wire-wrap boards are not recommended. The two ground planes should be connected together at the low-impedance power-supply source.

Table 3. Bipolar (Offset Binary) Code Table (-V_{REFIN} to +V_{REFIN} Output)

INPUT*	OUTPUT
1111 1111 11(00)	$(+V_{REFIN}) \frac{511}{512}$
1000 0000 01(00)	$(+V_{REFIN}) \frac{1}{512}$
1000 0000 00(00)	0V
0111 1111 11(00)	$(-V_{REFIN}) \frac{1}{512}$
0000 0000 01(00)	$(-V_{REFIN}) \frac{511}{512}$
0000 0000 00(00)	$(-V_{REFIN}) \frac{512}{512} = -V_{REFIN}$

* Write 10-bit data words with two sub-LSB 0s because the DAC input latch is 12 bits wide.

DGND and AGND should be connected together at the chip. For the MAX504 in single-supply applications, connect V_{SS} to AGND at the chip. The best ground connection may be achieved by connecting the DAC's DGND and AGND pins together and connecting that point to the system analog ground plane. If the DAC's DGND is connected to the system digital ground, digital noise may get through to the DAC's analog portion.

Bypass V_{DD} (and V_{SS} in dual-supply mode) with a 0.1µF ceramic capacitor connected between V_{DD} and AGND (and between V_{SS} and AGND). Mount it with short leads close to the device. Ferrite beads may also be used to further isolate the analog and digital power supplies.

Figures 11a and 11b illustrate the grounding and bypassing scheme described.

Saving Power

When the DAC is not being used by the system, minimize power consumption by setting the appropriate code to minimize load current. For example, in bipolar mode, with a resistive load to ground, set the DAC code to mid-scale (see Table 3). If there is no output load, minimize internal loading on the reference by setting the DAC to all 0s (on the MAX504, use CLR). Under this condition, REF_{IN} is high impedance and the op amp operates at its minimum quiescent current.

Due to these low currents, the output settling time for a zero input code typically increases to 60µs (100µs max).

5V, Low-Power, Voltage-Output, Serial 10-Bit DACs

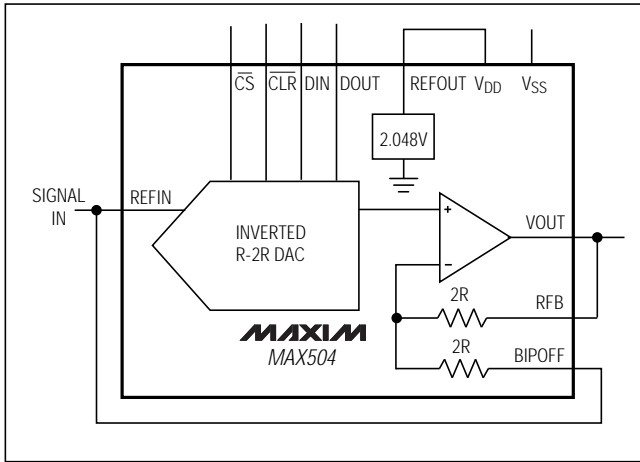

Figure 9. MAX504 Connected as Four-Quadrant Multiplier. The unused REFOUT is connected to VDD.

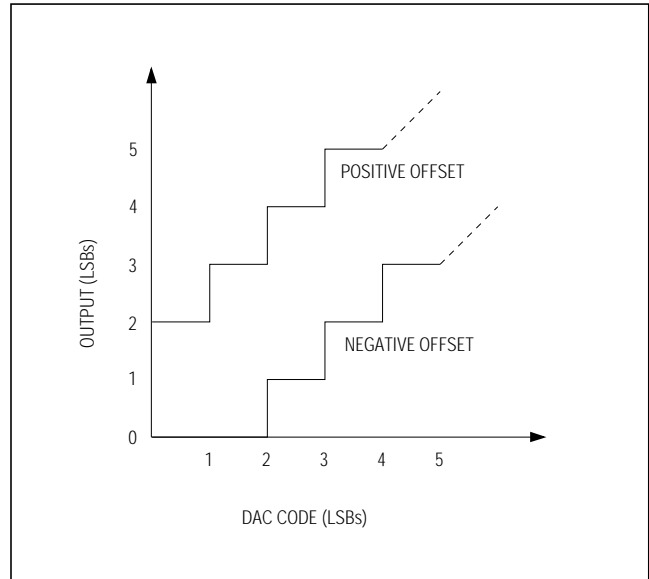

Figure 10. Single-Supply Offset

AC Considerations

Digital Feedthrough

High-speed serial data at any of the digital input or output pins may couple through the DAC package and cause internal stray capacitance to appear at the DAC output as noise, even though \overline{CS} is held high (see *Typical Operating Characteristics*). This digital feedthrough is tested by holding \overline{CS} high transmitting 0101... from DIN to DOUT.

Analog Feedthrough

Because of internal stray capacitance, higher frequency analog input signals may couple to the output as shown in the Analog Feedthrough vs. Frequency graph in the *Typical Operating Characteristics*. It is tested by holding \overline{CS} high, setting the DAC code to all 0s, and sweeping REFIN.

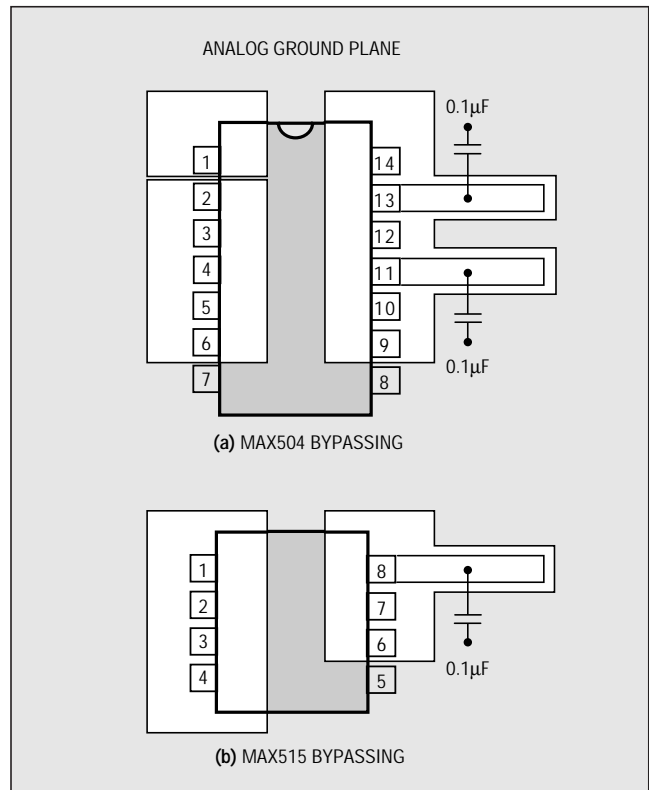

Figure 11. Power-Supply Bypassing

5V, Low-Power, Voltage-Output, Serial 10-Bit DACs

Pin Configurations (continued)

Chip Information

TRANSISTOR COUNT: 922

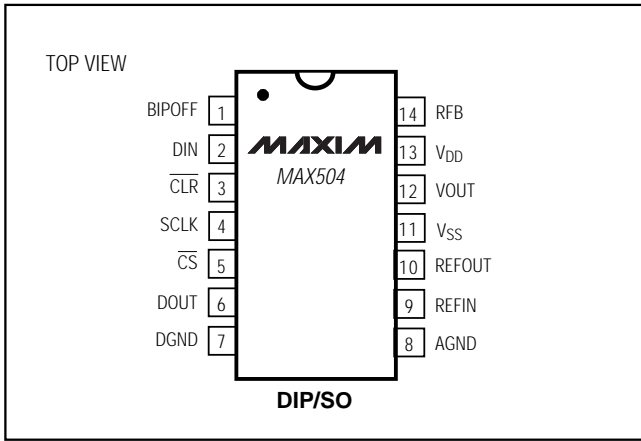

5V, Low-Power, Voltage-Output, Serial 10-Bit DACs

Package Information

MAX504/MAX515

	INCHES		MILLIMETERS	
	MIN	MAX	MIN	MAX
A	0.053	0.069	1.35	1.75
A1	0.004	0.010	0.10	0.25
B	0.014	0.019	0.35	0.49
C	0.007	0.010	0.19	0.25
e	0.050		1.27	
E	0.150	0.157	3.80	4.00
H	0.228	0.244	5.80	6.20
h	0.010	0.020	0.25	0.50
L	0.016	0.050	0.40	1.27

	INCHES		MILLIMETERS		N	MS012
	MIN	MAX	MIN	MAX		
D	0.189	0.197	4.80	5.00	8	A
D	0.337	0.344	8.55	8.75	14	B
D	0.386	0.394	9.80	10.00	16	C

NOTES:
 1. D&E DO NOT INCLUDE MOLD FLASH
 2. MOLD FLASH OR PROTRUSIONS NOT TO EXCEED .15mm (.006")
 3. LEADS TO BE COPLANAR WITHIN .102mm (.004")
 4. CONTROLLING DIMENSION: MILLIMETER
 5. MEETS JEDEC MS012-XX AS SHOWN IN ABOVE TABLE
 6. N = NUMBER OF PINS

MAXIM 120 SAN GABRIEL DR. SIMONVILLE, GA 30669 TEL: 404/737-7791 PREPROPRIETARY INFORMATION

PACKAGE FAMILY OUTLINE: SOIC .150" TITLE

1/1 21-0041 A DOCUMENT CONTROL NUMBER REV

5V, Low-Power, Voltage-Output, Serial 10-Bit DACs

Package Information (continued)

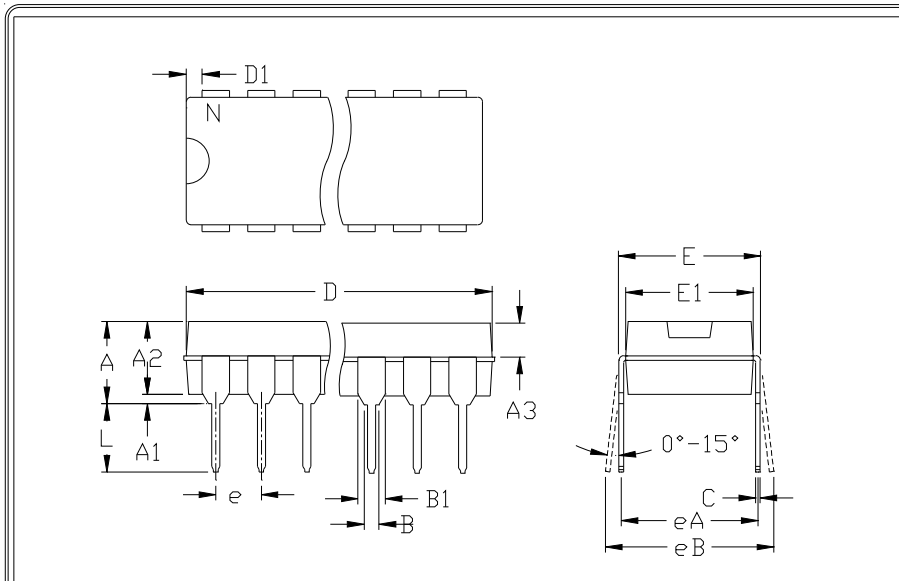

	INCHES		MILLIMETERS	
	MIN	MAX	MIN	MAX
A	---	0.200	---	5.08
A1	0.015	---	0.38	---
A2	0.125	0.175	3.18	4.45
A3	0.055	0.080	1.40	2.03
B	0.016	0.022	0.41	0.56
B1	0.045	0.065	1.14	1.65
C	0.008	0.012	0.20	0.30
D1	0.005	0.080	0.13	2.03
E	0.300	0.325	7.62	8.26
E1	0.240	0.310	6.10	7.87
e	0.100	---	2.54	---
eA	0.300	---	7.62	---
eB	---	0.400	---	10.16
L	0.115	0.150	2.92	3.81

	INCHES		MILLIMETERS		N	MS001
	MIN	MAX	MIN	MAX		
D	0.348	0.390	8.84	9.91	8	AB
D	0.735	0.765	18.67	19.43	14	AC
D	0.745	0.765	18.92	19.43	16	AA
D	0.885	0.915	22.48	23.24	18	AD
D	1.015	1.045	25.78	26.54	20	AE
D	1.14	1.265	28.96	32.13	24	AF
D	1.360	1.380	34.54	35.05	28	*5

- NOTES:
1. D&E DO NOT INCLUDE MOLD FLASH
 2. MOLD FLASH OR PROTRUSIONS NOT TO EXCEED .15mm (.006")
 3. CONTROLLING DIMENSION: MILLIMETER
 4. MEETS JEDEC MS001-XX AS SHOWN IN ABOVE TABLE
 5. SIMILAR TO JEDEC MO-058AB
 6. N = NUMBER OF PINS

PACKAGE FAMILY OUTLINE: PDIP .300"

21-0043 A
DOCUMENT CONTROL NUMBER REV.

Maxim cannot assume responsibility for use of any circuitry other than circuitry entirely embodied in a Maxim product. No circuit patent licenses are implied. Maxim reserves the right to change the circuitry and specifications without notice at any time.