

MC10EP105

Product Preview

Quad 2-Input Differential AND/NAND

The MC10EP105 is a 2-input differential AND/NAND gate. Each gate is functionally equivalent to a EP05 and LVEL05 devices. With AC performance much faster than the LVEL05 device, the EP105 is ideal for applications requiring the fastest AC performance available. All VCC and VEE pins must be externally connected to power supply to guarantee proper operation.

- 190ps Typical Propagation Delay
- High Bandwidth to 3 Ghz Typical
- ECL mode: 0V VCC with VEE = -3.0V to -5.5V
- PECL mode: 3.0V to 5.5V VCC with VEE = 0V
- Internal Input Pulldown Resistors
- ESD Protection: >2KV HBM, >100V MM
- New Differential Input Common Mode Range
- Moisture Sensitivity Level 2
- For Additional Information, See Application Note AND8003/D
- Flammability Rating: UL-94 code V-0 @ 1/8", Oxygen Index 28 to 34
- Transistor Count = 444 devices



ON Semiconductor
Formerly a Division of Motorola
<http://onsemi.com>

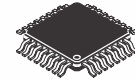

32-LEAD TQFP
FA SUFFIX
CASE 873A

MARKING DIAGRAM*

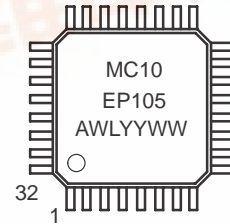

A = Assembly Location
WL = Wafer Lot
YY = Year
WW = Work Week

*For additional information, see Application Note AND8002/D

LOGIC DIAGRAM

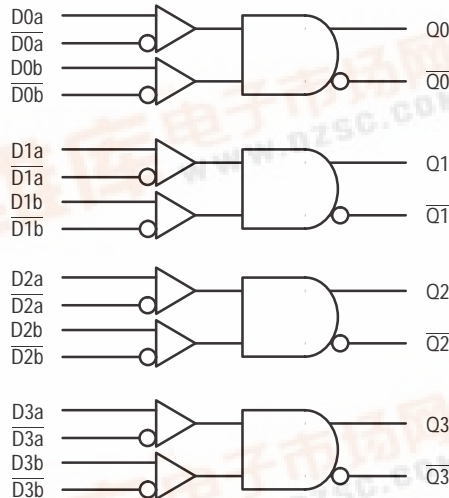

PIN DESCRIPTION

PIN	FUNCTION
Dna, Dnb, \overline{Dna} , \overline{Dnb}	ECL Data Inputs
Qn, \overline{Qn}	ECL Data Outputs
VBB	Reference Voltage Output
VCC	Positive Supply
VEE	Negative, 0 Supply

TRUTH TABLE

Dna	Dnb	\overline{Dna}	\overline{Dnb}	Qn	\overline{Qn}
L	L	H	H	L	H
L	H	H	L	L	H
H	L	L	H	L	H
H	H	L	L	H	L

ORDERING INFORMATION

Device	Package	Shipping
MC10EP105FA	TQFP	250 Units/Tray
MC10EP105FAR2	TQFP	2000 Tape & Reel



MC10EP105

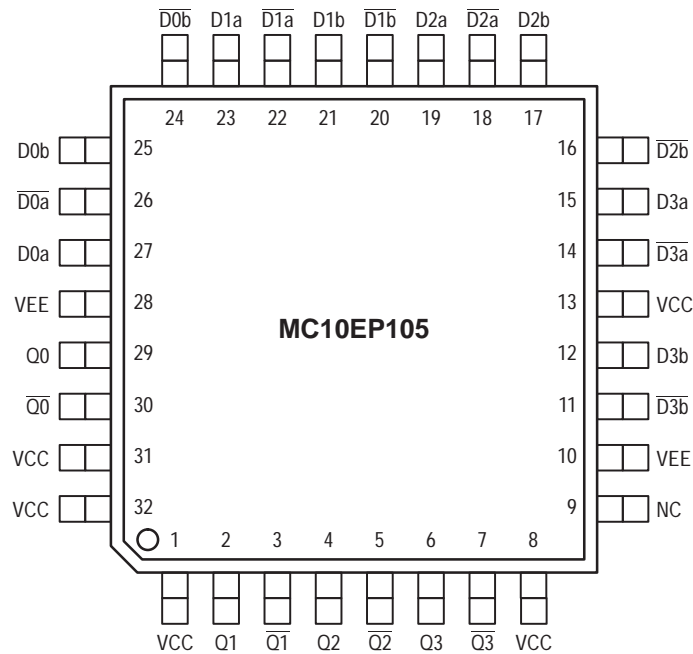

Figure 1. 32-Lead TQFP Pinout
(Top View)

Warning: All V_{CC} and V_{EE} pins must be externally connected to Power Supply to guarantee proper operation.

MAXIMUM RATINGS*

Symbol	Parameter	Value	Unit	
V _{EE}	Power Supply (V _{CC} = 0V)	-6.0 to 0	VDC	
V _{CC}	Power Supply (V _{EE} = 0V)	6.0 to 0	VDC	
V _I	Input Voltage (V _{CC} = 0V, V _I not more negative than V _{EE})	-6.0 to 0	VDC	
V _I	Input Voltage (V _{EE} = 0V, V _I not more positive than V _{CC})	6.0 to 0	VDC	
I _{out}	Output Current	Continuous Surge	50 100	mA
T _A	Operating Temperature Range	-40 to +85	°C	
T _{stg}	Storage Temperature	-65 to +150	°C	
θ _{JA}	Thermal Resistance (Junction-to-Ambient)	Still Air 500lfpm	80 55	°C/W
θ _{JC}	Thermal Resistance (Junction-to-Case)	12 to 17	°C/W	
T _{sol}	Solder Temperature (<2 to 3 Seconds: 245°C desired)	265	°C	

* Maximum Ratings are those values beyond which damage to the device may occur.

MC10EP105

DC CHARACTERISTICS, ECL/LVECL ($V_{CC} = 0V$; $V_{EE} = -5.5V$ to $-3.0V$) (Note 4.)

Symbol	Characteristic	-40°C			25°C			85°C			Unit
		Min	Typ	Max	Min	Typ	Max	Min	Typ	Max	
IEE	Power Supply Current (Note 1.)					59					mA
VOH	Output HIGH Voltage (Note 2.)	-1135	-1060	-885	-1070	-945	-820	-1010	-885	-760	mV
VOL	Output LOW Voltage (Note 2.)	-1935	-1810	-1685	-1870	-1745	-1620	-1810	-1685	-1560	mV
VIH	Input HIGH Voltage Single Ended	-1210		-885	-1145		-820	-1085		-760	mV
VIL	Input LOW Voltage Single Ended	-1935		-1610	-1870		-1545	-1810		-1485	mV
VIHCMR	Input HIGH Voltage Common Mode Range (Note 3.)	$V_{EE}+2.0$		0.0	$V_{EE}+2.0$		0.0	$V_{EE}+2.0$		0.0	V
I _{IH}	Input HIGH Current			150			150			150	μA
I _{IL}	Input LOW Current	D D̄	0.5 -150		0.5 -150			0.5 -150			μA

NOTE: 10EP circuits are designed to meet the DC specifications shown in the above table after thermal equilibrium has been established. The circuit is in a test socket or mounted on a printed circuit board and transverse airflow greater than 500lfpm is maintained.

1. $V_{CC} = 0V$, $V_{EE} = V_{EEmin}$ to V_{EEmax} , all other pins floating.
2. All loading with 50 ohms to $V_{CC}-2.0$ volts.
3. V_{IHCMR} min varies 1:1 with V_{EE} , max varies 1:1 with V_{CC} .
4. Input and output parameters vary 1:1 with V_{CC} .

DC CHARACTERISTICS, LVPECL ($V_{CC} = 3.3V \pm 0.3V$, $V_{EE} = 0V$) (Note 8.)

Symbol	Characteristic	-40°C			25°C			85°C			Unit
		Min	Typ	Max	Min	Typ	Max	Min	Typ	Max	
IEE	Power Supply Current (Note 5.)					59					mA
VOH	Output HIGH Voltage (Note 6.)	2165	2240	2415	2230	2355	2480	2290	2415	2540	mV
VOL	Output LOW Voltage (Note 6.)	1365	1490	1615	1430	1555	1680	1490	1615	1740	mV
VIH	Input HIGH Voltage Single Ended	2090		2415	2155		2480	2215		2540	mV
VIL	Input LOW Voltage Single Ended	1365		1690	1430		1755	1490		1815	mV
VIHCMR	Input HIGH Voltage Common Mode Range (Note 7.)	2.0		3.3	2.0		3.3	2.0		3.3	V
I _{IH}	Input HIGH Current			150			150			150	μA
I _{IL}	Input LOW Current	D D̄	0.5 -150		0.5 -150			0.5 -150			μA

NOTE: 10EP circuits are designed to meet the DC specifications shown in the above table after thermal equilibrium has been established. The circuit is in a test socket or mounted on a printed circuit board and transverse airflow greater than 500lfpm is maintained.

5. $V_{CC} = 3.3V$, $V_{EE} = 0V$, all other pins floating.
6. All loading with 50 ohms to $V_{CC}-2.0$ volts.
7. V_{IHCMR} min varies 1:1 with V_{EE} , max varies 1:1 with V_{CC} .
8. Input and output parameters vary 1:1 with V_{CC} .

MC10EP105

DC CHARACTERISTICS, PECL ($V_{CC} = 5.0V \pm 0.5V$, $V_{EE} = 0V$) (Note 12.)

Symbol	Characteristic	-40°C			25°C			85°C			Unit
		Min	Typ	Max	Min	Typ	Max	Min	Typ	Max	
IEE	Power Supply Current (Note 9.)					59					mA
VOH	Output HIGH Voltage (Note 10.)	3865	3940	4115	3930	4055	4180	3990	4115	4240	mV
VOL	Output LOW Voltage (Note 10.)	3065	3190	3315	3130	3255	3380	3190	3315	3440	mV
VIH	Input HIGH Voltage Single Ended	3790		4115	3855		4180	3915		4240	mV
VIL	Input LOW Voltage Single Ended	3065		3390	3130		3455	3190		3515	mV
VIHCMR	Input HIGH Voltage Common Mode Range (Note 11.)	2.0		5.0	2.0		5.0	2.0		5.0	V
I _{IH}	Input HIGH Current			150			150			150	μA
I _{IL}	Input LOW Current	D D̄	0.5 -150		0.5 -150			0.5 -150			μA

NOTE: 10EP circuits are designed to meet the DC specifications shown in the above table after thermal equilibrium has been established. The circuit is in a test socket or mounted on a printed circuit board and transverse airflow greater than 500lfpm is maintained.

9. $V_{CC} = 5.0V$, $V_{EE} = 0V$, all other pins floating.

10. All loading with 50 ohms to V_{CC} -2.0 volts.

11. V_{IHCMR} min varies 1:1 with V_{EE} , max varies 1:1 with V_{CC} .

12. Input and output parameters vary 1:1 with V_{CC} .

AC CHARACTERISTICS ($V_{CC} = 0V$; $V_{EE} = -3.0V$ to $-5.5V$) or ($V_{CC} = 3.0V$ to $5.5V$; $V_{EE} = 0V$)

Symbol	Characteristic	-40°C			25°C			85°C			Unit
		Min	Typ	Max	Min	Typ	Max	Min	Typ	Max	
f _{max}	Maximum Toggle Frequency (Note 13.)		3.0			3.0			3.0		GHz
t _{PLH} , t _{PHL}	Propagation Delay to Output Differential					190					ps
t _{SKEW}	Duty Cycle Skew (Note 14.)		5.0			5.0	20		5.0	20	ps
t _{JITTER}	Cycle-to-Cycle Jitter		TBD			TBD			TBD		ps
V _{PP}	Input Voltage Swing (Diff.)	150	800	1200	150	800	1200	150	800	1200	mV
t _r , t _f	Output Rise/Fall Times (20% – 80%)					120					ps

13. F_{max} guaranteed for functionality only. V_{OL} and V_{OH} levels are guaranteed at DC only.

14. Skew is measured between outputs under identical transitions. Duty cycle skew is defined only for differential operation when the delays are measured from the cross point of the inputs to the cross point of the outputs.

MC10EP105

PACKAGE DIMENSIONS

TQFP
FA SUFFIX
32-LEAD PLASTIC PACKAGE
CASE 873A-02
ISSUE A

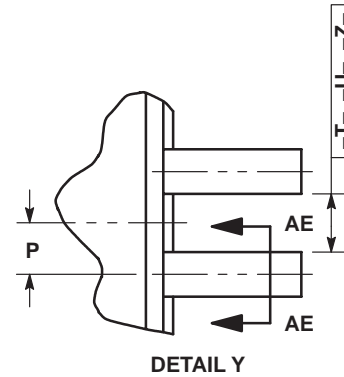
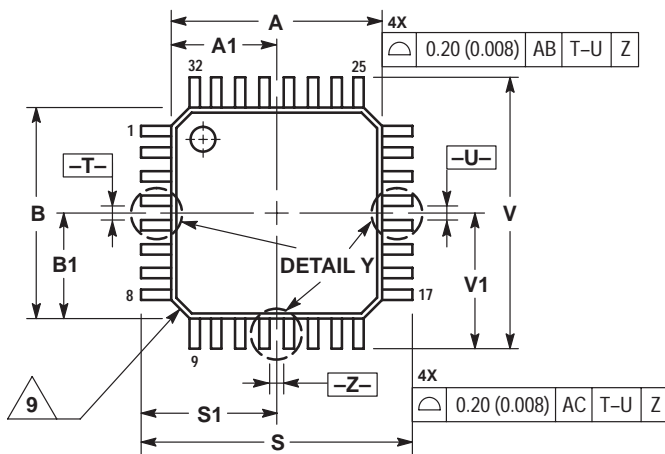

NOTES:

- DIMENSIONING AND TOLERANCING PER ANSI Y14.5M, 1982.
- CONTROLLING DIMENSION: MILLIMETER.
- DATUM PLANE -AB- IS LOCATED AT BOTTOM OF LEAD AND IS COINCIDENT WITH THE LEAD WHERE THE LEAD EXITS THE PLASTIC BODY AT THE BOTTOM OF THE PARTING LINE.
- DATUMS -T-, -U-, AND -Z- TO BE DETERMINED AT DATUM PLANE -AB-.
- DIMENSIONS S AND V TO BE DETERMINED AT SEATING PLANE -AC-.
- DIMENSIONS A AND B DO NOT INCLUDE MOLD PROTRUSION. ALLOWABLE PROTRUSION IS 0.250 (0.010) PER SIDE. DIMENSIONS A AND B DO INCLUDE MOLD MISMATCH AND ARE DETERMINED AT DATUM PLANE -AB-.
- DIMENSION D DOES NOT INCLUDE DAMBAR PROTRUSION. DAMBAR PROTRUSION SHALL NOT CAUSE THE D DIMENSION TO EXCEED 0.520 (0.020).
- MINIMUM SOLDER PLATE THICKNESS SHALL BE 0.0076 (0.0003).
- EXACT SHAPE OF EACH CORNER MAY VARY FROM DEPICTION.

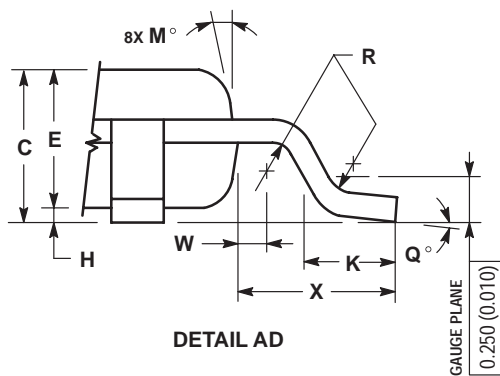
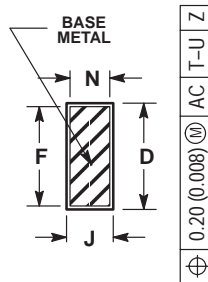
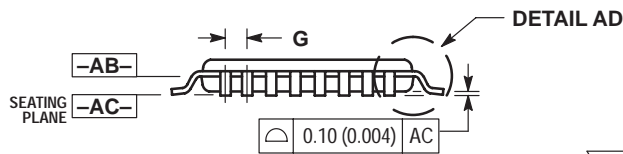

DIM	MILLIMETERS		INCHES	
	MIN	MAX	MIN	MAX
A	7.000 BSC		0.276 BSC	
A1	3.500 BSC		0.138 BSC	
B	7.000 BSC		0.276 BSC	
B1	3.500 BSC		0.138 BSC	
C	1.400	1.600	0.055	0.063
D	0.300	0.450	0.012	0.018
E	1.350	1.450	0.053	0.057
F	0.300	0.400	0.012	0.016
G	0.800 BSC		0.031 BSC	
H	0.050	0.150	0.002	0.006
J	0.090	0.200	0.004	0.008
K	0.500	0.700	0.020	0.028
M	12° REF		12° REF	
N	0.090	0.160	0.004	0.006
P	0.400 BSC		0.016 BSC	
Q	1°	5°	1°	5°
R	0.150	0.250	0.006	0.010
S	9.000 BSC		0.354 BSC	
S1	4.500 BSC		0.177 BSC	
V	9.000 BSC		0.354 BSC	
V1	4.500 BSC		0.177 BSC	
W	0.200 REF		0.008 REF	
X	1.000 REF		0.039 REF	

Notes

Notes

MC10EP105

ON Semiconductor and  are trademarks of Semiconductor Components Industries, LLC (SCILLC). SCILLC reserves the right to make changes without further notice to any products herein. SCILLC makes no warranty, representation or guarantee regarding the suitability of its products for any particular purpose, nor does SCILLC assume any liability arising out of the application or use of any product or circuit, and specifically disclaims any and all liability, including without limitation special, consequential or incidental damages. "Typical" parameters which may be provided in SCILLC data sheets and/or specifications can and do vary in different applications and actual performance may vary over time. All operating parameters, including "Typicals" must be validated for each customer application by customer's technical experts. SCILLC does not convey any license under its patent rights nor the rights of others. SCILLC products are not designed, intended, or authorized for use as components in systems intended for surgical implant into the body, or other applications intended to support or sustain life, or for any other application in which the failure of the SCILLC product could create a situation where personal injury or death may occur. Should Buyer purchase or use SCILLC products for any such unintended or unauthorized application, Buyer shall indemnify and hold SCILLC and its officers, employees, subsidiaries, affiliates, and distributors harmless against all claims, costs, damages, and expenses, and reasonable attorney fees arising out of, directly or indirectly, any claim of personal injury or death associated with such unintended or unauthorized use, even if such claim alleges that SCILLC was negligent regarding the design or manufacture of the part. SCILLC is an Equal Opportunity/Affirmative Action Employer.

PUBLICATION ORDERING INFORMATION

North America Literature Fulfillment:

Literature Distribution Center for ON Semiconductor
P.O. Box 5163, Denver, Colorado 80217 USA
Phone: 303-675-2175 or 800-344-3860 Toll Free USA/Canada
Fax: 303-675-2176 or 800-344-3867 Toll Free USA/Canada
Email: ONlit@hibbertco.com

N. American Technical Support: 800-282-9855 Toll Free USA/Canada

EUROPE: LDC for ON Semiconductor – European Support

German Phone: (+1) 303-308-7140 (M-F 2:30pm to 5:00pm Munich Time)
Email: ONlit-german@hibbertco.com
French Phone: (+1) 303-308-7141 (M-F 2:30pm to 5:00pm Toulouse Time)
Email: ONlit-french@hibbertco.com
English Phone: (+1) 303-308-7142 (M-F 1:30pm to 5:00pm UK Time)
Email: ONlit@hibbertco.com

ASIA/PACIFIC: LDC for ON Semiconductor – Asia Support

Phone: 303-675-2121 (Tue-Fri 9:00am to 1:00pm, Hong Kong Time)
Toll Free from Hong Kong 800-4422-3781
Email: ONlit-asia@hibbertco.com

JAPAN: ON Semiconductor, Japan Customer Focus Center
4-32-1 Nishi-Gotanda, Shinagawa-ku, Tokyo, Japan 141-8549

Phone: 81-3-5740-2745
Email: r14525@onsemi.com

Fax Response Line: 303-675-2167
800-344-3810 Toll Free USA/Canada

ON Semiconductor Website: <http://onsemi.com>

For additional information, please contact your local Sales Representative.