

International IOR Rectifier

60EPU06
60APU06

Ultrafast Soft Recovery Diode

Features

- Ultrafast Recovery
- 175°C Operating Junction Temperature

Benefits

- Reduced RFI and EMI
- Higher Frequency Operation
- Reduced Snubbing
- Reduced Parts Count

$$t_{rr} = 34ns \text{ (typ)}$$

$$I_{F(AV)} = 60Amp$$

$$V_R = 600V$$

Description/ Applications



These diodes are optimized to reduce losses and EMI/ RFI in high frequency power conditioning systems. The softness of the recovery eliminates the need for a snubber in most applications. These devices are ideally suited for HF welding, power converters and other applications where switching losses are not significant portion of the total losses.

Absolute Maximum Ratings

Parameters	Max	Units
V_R Cathode to Anode Voltage	600	V
$I_{F(AV)}$ Continuous Forward Current, $T_C = 116^\circ C$	60	A
I_{FSM} Single Pulse Forward Current, $T_C = 25^\circ C$	600	
$I_{FRM} \text{ ①}$ Maximum Repetitive Forward Current	120	
T_J, T_{STG} Operating Junction and Storage Temperatures	- 55 to 175	$^\circ C$

① Square Wave, 20kHz

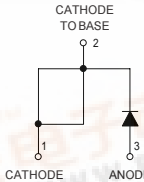
Case Styles

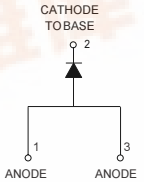
<p>60EPU06</p>  <p>CATHODE TO BASE</p>  <p>CATHODE ANODE</p> <p>TO-247AC (Modified)</p>	<p>60APU06</p>  <p>CATHODE TO BASE</p>  <p>ANODE ANODE</p> <p>TO-247AC</p>
---	--

Electrical Characteristics @ T_J = 25°C (unless otherwise specified)

Parameters	Min	Typ	Max	Units	Test Conditions
V _{BR} , V _r Breakdown Voltage, Blocking Voltage	600	-	-	V	I _R = 100μA
V _F Forward Voltage	-	1.35	1.68	V	I _F = 60A
	-	1.20	1.42	V	I _F = 60A, T _J = 125°C
	-	1.11	1.30	V	I _F = 60A, T _J = 175°C
I _R Reverse Leakage Current	-	-	50	μA	V _R = V _R Rated
	-	-	500	μA	T _J = 150°C, V _R = V _R Rated
C _T Junction Capacitance	-	39	-	pF	V _R = 600V

Dynamic Recovery Characteristics @ T_J = 25°C (unless otherwise specified)

Parameters	Min	Typ	Max	Units	Test Conditions
t _{rr} Reverse Recovery Time	-	34	45	ns	I _F = 1A, di _F /dt = 200A/μs, V _R = 30V
	-	81	-		T _J = 25°C
	-	164	-		T _J = 125°C
I _R Peak Recovery Current	-	7.4	-	A	T _J = 25°C
	-	17.0	-		T _J = 125°C
Q _{rr} Reverse Recovery Charge	-	300	-	nC	T _J = 25°C
	-	1394	-		T _J = 125°C

I_F = 60A
V_R = 200V
di_F/dt = 200A/μs

Thermal - Mechanical Characteristics

Parameters	Min	Typ	Max	Units
R _{thJC} Thermal Resistance, Junction to Case			0.63	K/W
R _{thCS} ② Thermal Resistance, Case to Heatsink		0.2		
Wt Weight		5.5		g
		0.2		(oz)
T Mounting Torque	1.2		2.4	N * m
	10		20	lbf.in

② Mounting Surface, Flat, Smooth and Greased

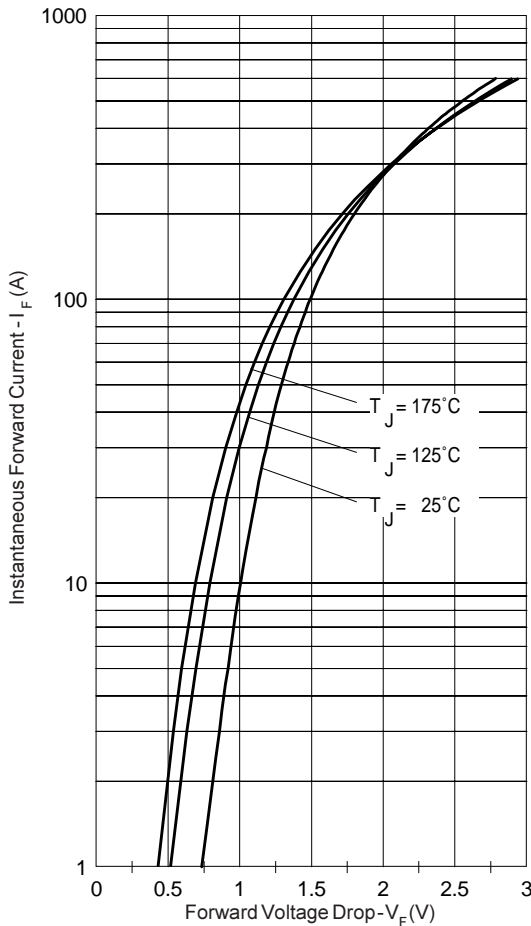

Fig. 1 - Typical Forward Voltage Drop Characteristics

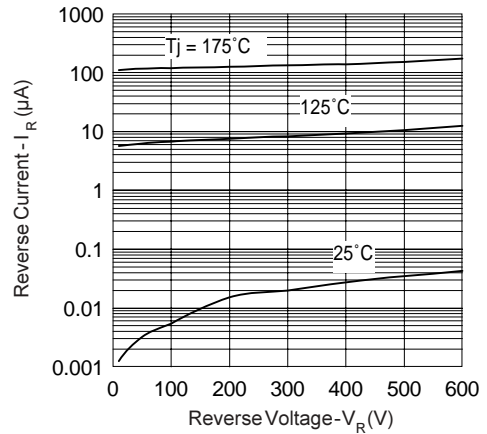

Fig. 2 - Typical Values Of Reverse Current Vs. Reverse Voltage

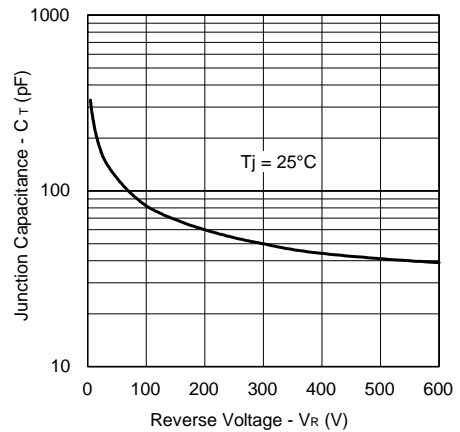

Fig. 3 - Typical Junction Capacitance Vs. Reverse Voltage

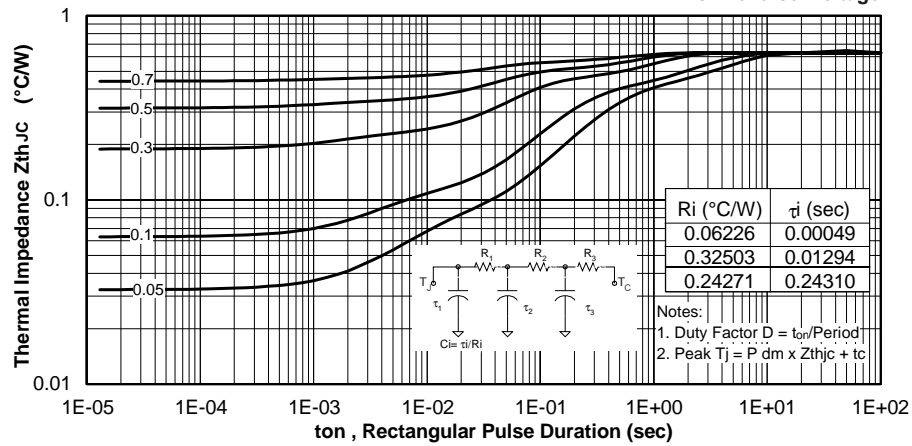

Fig. 4 - Max. Thermal Impedance Z_{thJc} Characteristics

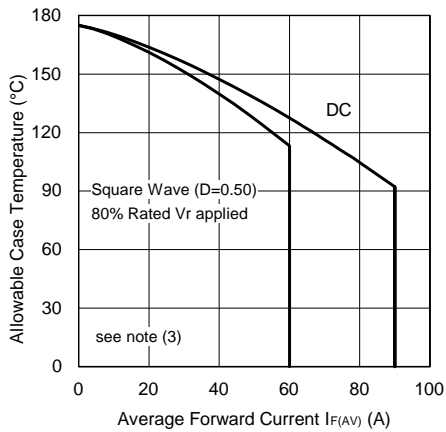

Fig. 5 - Max. Allowable Case Temperature Vs. Average Forward Current

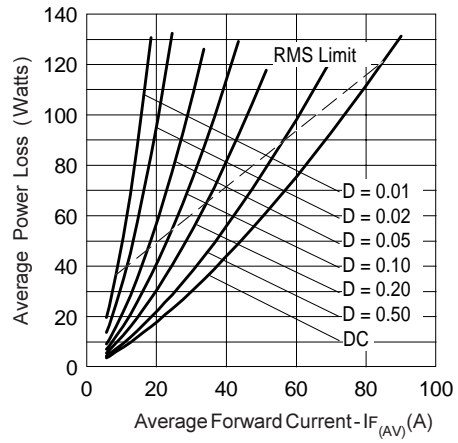

Fig. 6 - Forward Power Loss Characteristics

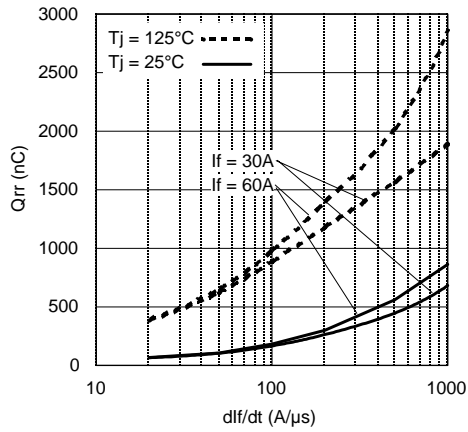

Fig. 7 - Typical Stored Charge vs. di/dt

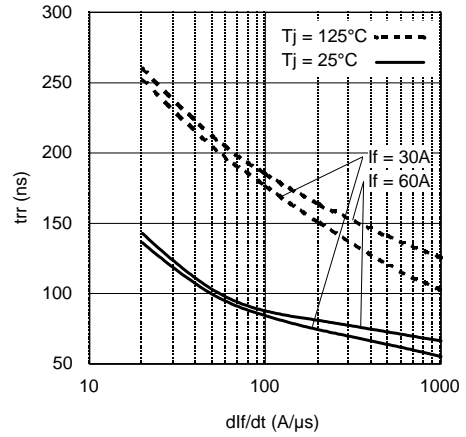

Fig. 8 - Typical Reverse Recovery Time vs. di/dt

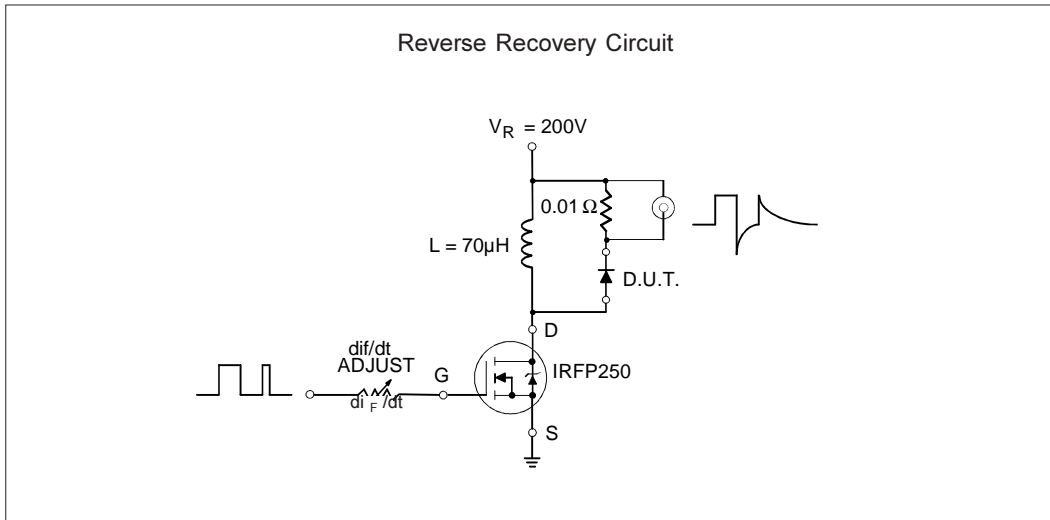

Fig. 7 - Reverse Recovery Parameter Test Circuit

- (3) Formula used: $T_C = T_J - (Pd + Pd_{REV}) \times R_{thJC}$;
 Pd = Forward Power Loss = $I_{F(AV)} \times V_{FM} @ (I_{F(AV)} / D)$ (see Fig. 6);
 Pd_{REV} = Inverse Power Loss = $V_{R1} \times I_R (1 - D)$; $I_R @ V_{R1} = 80\%$ rated V_R

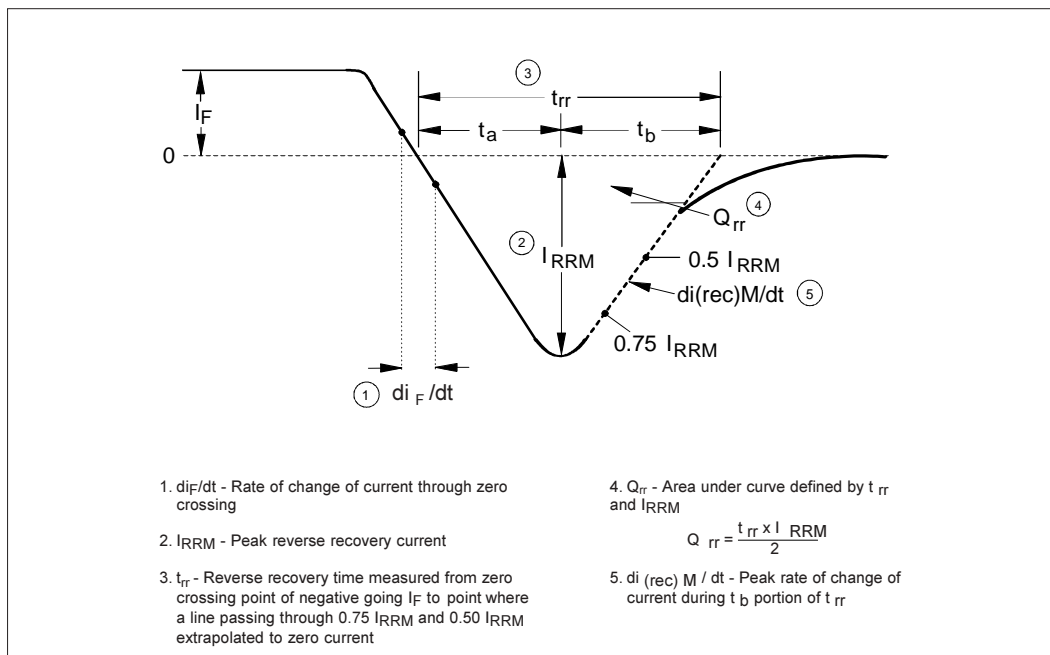
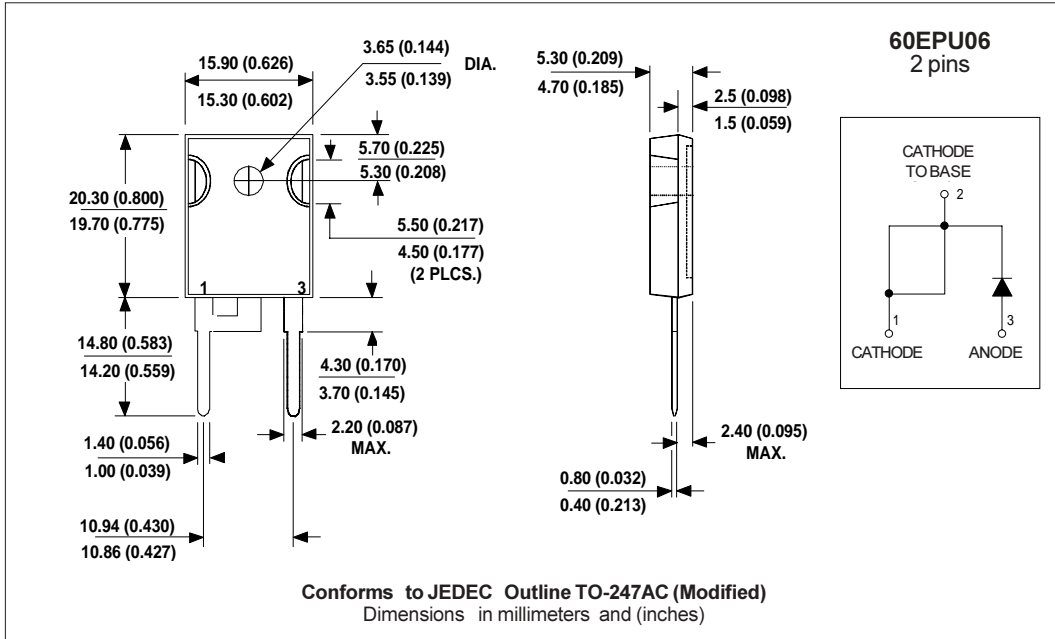
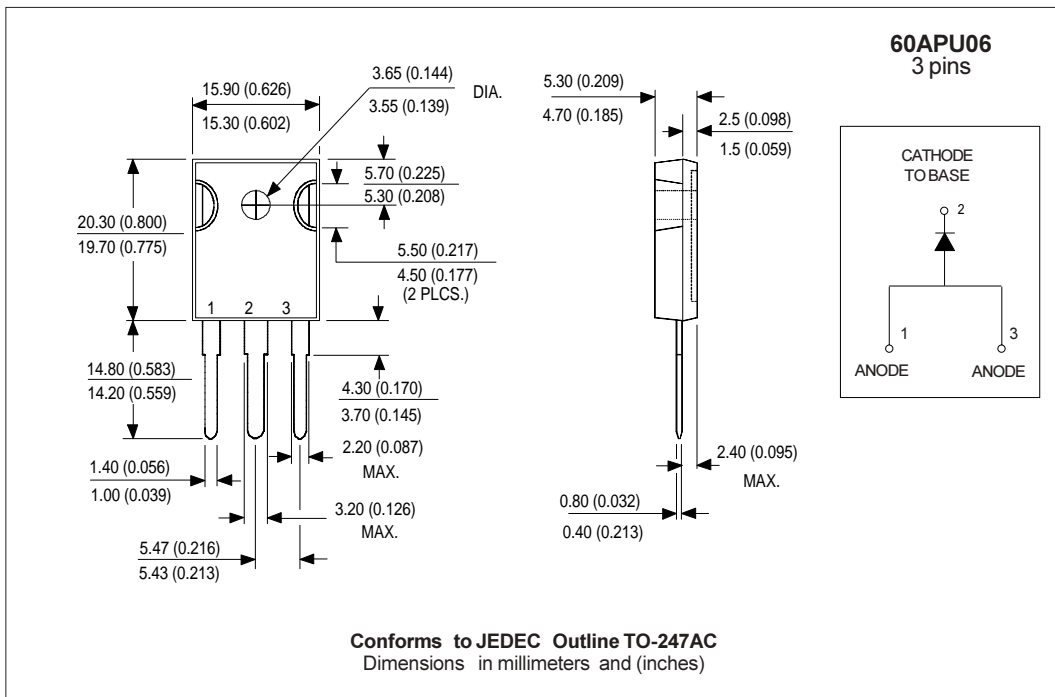

Fig. 8 - Reverse Recovery Waveform and Definitions

Outline Table



Outline Table



Ordering Information Table

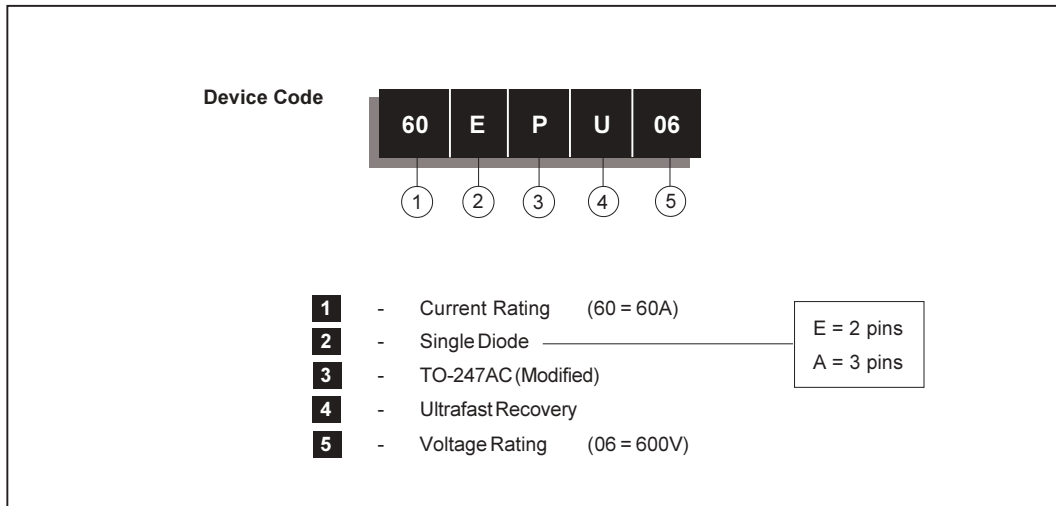

Data and specifications subject to change without notice.
 This product has been designed and qualified for Industrial Level.
 Qualification Standards can be found on IR's Web site.