



Single +5V, Fully Integrated, 1.25Gbps Laser Diode Driver

General Description

The MAX3261 is a complete, easy-to-program, single +5V-powered, 1.25Gbps laser diode driver with complementary enable inputs and automatic power control (APC). The MAX3261 accepts differential PECL inputs and provides complementary output currents. A temperature-stabilized reference voltage is provided to simplify laser current programming. This allows modulation current to be programmed up to 30mA and bias current to be programmed up to 60mA with two external resistors.

Complementary enable inputs allow the MAX3261 to interface with open-fiber-control architecture—a feature not found in other 1.25Gbps laser diode drivers.

An APC circuit is provided to maintain constant laser power in transmitters that use a monitor photodiode. Only two external components are required to implement the APC function.

The MAX3261's fully integrated feature set includes a TTL-compatible laser failure indicator and a programmable slow-start circuit to prevent laser damage. The slow-start is preset to 50ns and can be extended by adding an external capacitor.

Applications

- Laser Diode Transmitters
- 531Mbps and 1062Mbps Fibre Channel
- 622Mbps SDH/SONET
- Gigabit Ethernet

Pin Configuration

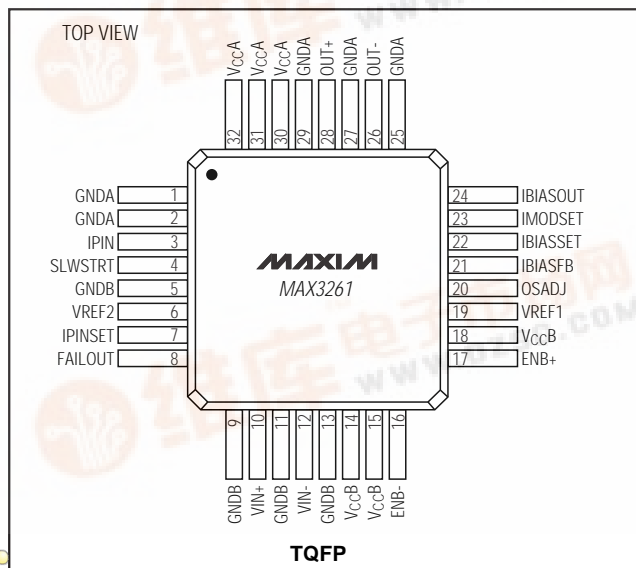

Features

- ◆ Rise Times Less than 250ps
- ◆ Differential PECL Inputs
- ◆ Single +5V Supply
- ◆ Automatic Power Control
- ◆ Temperature-Compensated Reference Voltage
- ◆ Complementary Enable Inputs

Ordering Information

PART	TEMP. RANGE	PIN-PACKAGE
MAX3261CCJ	0°C to +70°C	32 TQFP
MAX3261ECJ	-40°C to +85°C	32 TQFP
MAX3261E/D	-40°C to +85°C	Dice*

*Dice are designed to operate over a -40°C to +140°C junction temperature (T_j) range. Tested and guaranteed at $T_j = +25^\circ\text{C}$.

Typical Operating Circuit

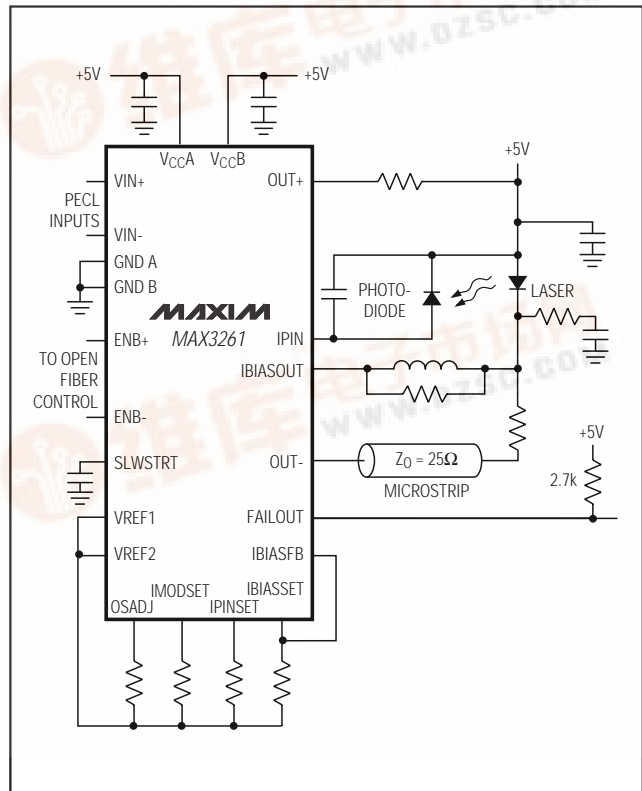

MAX3261

Single +5V, Fully Integrated, 1.25Gbps Laser Diode Driver

ABSOLUTE MAXIMUM RATINGS

Terminal Voltage (with respect to GND)	Output Current
Supply Voltages (V_{CCA} , V_{CCB}).....-0.3V to 6V	VREF1, VREF2.....0mA to 20mA
VIN+, VIN-, FAILOUT.....0V to V_{CC-}	SLWSTRT.....0mA to 5mA
OUT+, OUT-, IBIASOUT.....1.5V to V_{CC-}	Continuous Power Dissipation ($T_A = +70^\circ\text{C}$)
ENB+, ENB-..... V_{CC-} or 5.5V, whichever is smaller	TQFP (derate 10.2mW/ $^\circ\text{C}$ above $+70^\circ\text{C}$).....816mW
Differential Input Voltage ($ V_{IN+} - V_{IN-} $).....3.8V	Operating Temperature Ranges
Input Current	MAX3261CCJ..... 0°C to $+70^\circ\text{C}$
IBIASOUT.....0mA to 75mA	MAX3261ECJ..... -40°C to $+85^\circ\text{C}$
OUT+, OUT-.....0mA to 40mA	Junction Temperature..... $+150^\circ\text{C}$
IBIASSET.....0mA to 1.875mA	Storage Temperature Range..... -55°C to $+175^\circ\text{C}$
IMODSET.....0mA to 2mA	Processing Temperature (die)..... $+400^\circ\text{C}$
IPIN, IPINSET, OSADJ.....0mA to 2mA	
FAILOUT.....0mA to 10mA	
IBIASFB.....-2mA to 2mA	

Stresses beyond those listed under "Absolute Maximum Ratings" may cause permanent damage to the device. These are stress ratings only, and functional operation of the device at these or any other conditions beyond those indicated in the operational sections of the specifications is not implied. Exposure to absolute maximum rating conditions for extended periods may affect device reliability.

DC ELECTRICAL CHARACTERISTICS

($V_{CC} = V_{CCA} = V_{CCB} = +4.75\text{V}$ to $+5.25\text{V}$, $T_A = T_{MIN}$ to T_{MAX} , unless otherwise noted. Typical values are at $V_{CC} = +5\text{V}$ and $T_A = +25^\circ\text{C}$.) (Note 1)

PARAMETER	SYMBOL	CONDITIONS	MIN	TYP	MAX	UNITS
Range of Programmable Laser Bias Current	IBIAS				60	mA
Reference Voltage	VREF	$T_A = +25^\circ\text{C}$	3.15	3.3	3.45	V
Available Reference Current	IREF			12		mA
Supply Current	I _{VCC}	(Note 2)			50	mA
PECL Input High	V _{IH}		$V_{CC} - 1.165$			V
PECL Input Low	V _{IL}			$V_{CC} - 1.475$		V
TTL Input High	V _{IH}		2			V
TTL Input Low	V _{IL}				0.8	V
FAILOUT Output High	V _{OH}	Loaded with 2.7k Ω pull-up resistor to V_{CC}	4.5			V
FAILOUT Output Low	V _{OL}	Loaded with 2.7k Ω pull-up resistor to V_{CC}			0.5	V

Note 1: Dice are tested at $T_A = +25^\circ\text{C}$.

Note 2: $I_{VCC} = I_{VCCA} + I_{VCCB}$, $I_{BIAS} = 60\text{mA}$, $I_{MOD} = 30\text{mA}$, and $I_{PIN} = 140\mu\text{A}$.

AC ELECTRICAL CHARACTERISTICS

($V_{CC} = V_{CCA} = V_{CCB} = +4.75\text{V}$ to $+5.25\text{V}$, R_{LOAD} (at OUT+ and OUT-) = 25 Ω connected to V_{CC} , $T_A = -40^\circ\text{C}$ to $+85^\circ\text{C}$, unless otherwise noted. Typical values are at $V_{CC} = +5\text{V}$ and $T_A = +25^\circ\text{C}$.) (Note 3)

PARAMETER	SYMBOL	CONDITIONS	MIN	TYP	MAX	UNITS
Range of Programmable Modulation Current	I _{MOD}	Minimum differential input swing is 1100mVp-p (Note 4)			30	mA
Modulation-Current Rise and Fall Time	t _R , t _F	I _{BIAS} = 25mA, I _{MOD} = 12mA, 4ns unit interval; measured from 10% to 90%.			250	ps
Aberrations, Rising and Falling Edge		I _{MOD} = 12mA, $T_A = +25^\circ\text{C}$		± 10		%
			MAX3261E/D		± 15	
Modulation-Current Pulse-Width Distortion	PWD	I _{BIAS} = 25mA, I _{MOD} = 12mA, 4ns unit interval			80	ps

Note 3: AC characteristics are guaranteed by design and characterization.

Note 4: An 1100mVp-p differential is equivalent to complementary 550mVp-p signals on VIN+ and VIN-.

Single +5V, Fully Integrated, 1.25Gbps Laser Diode Driver

MAX3261

Typical Operating Characteristics

(MAX3261E/D, load at OUT+ and OUT- = 25Ω, V_{CC} = V_{CC}A = V_{CC}B = +5V, T_A = +25°C, unless otherwise noted.)

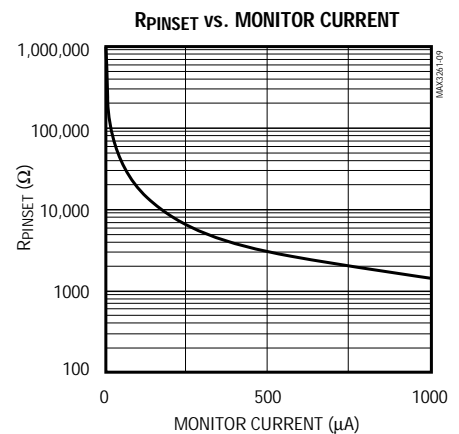
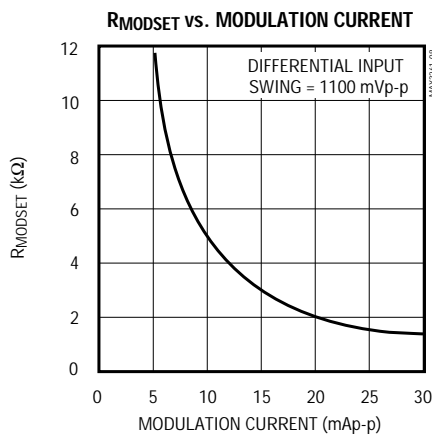
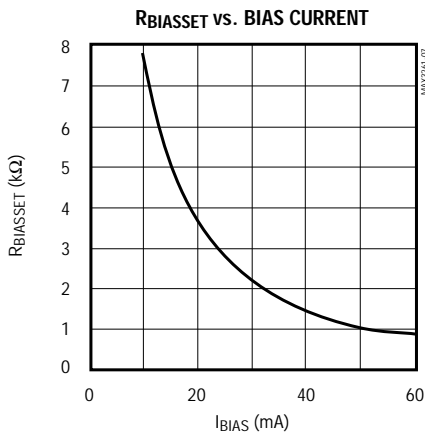
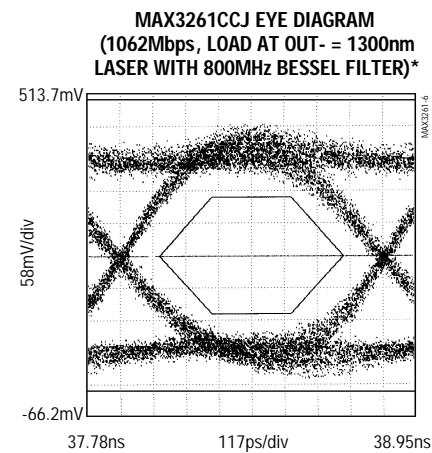
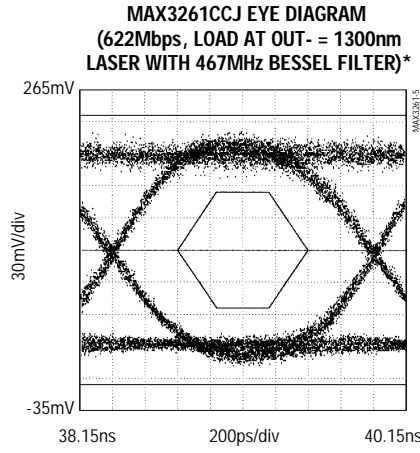
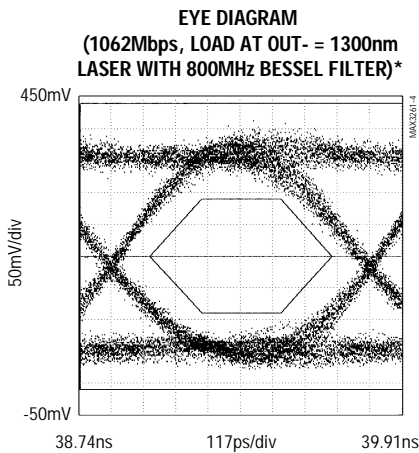
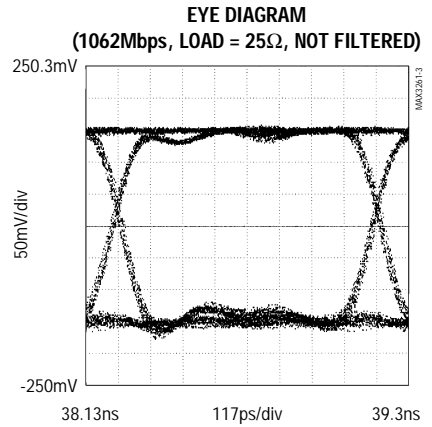
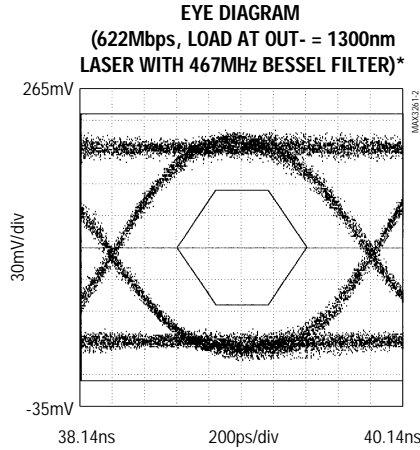
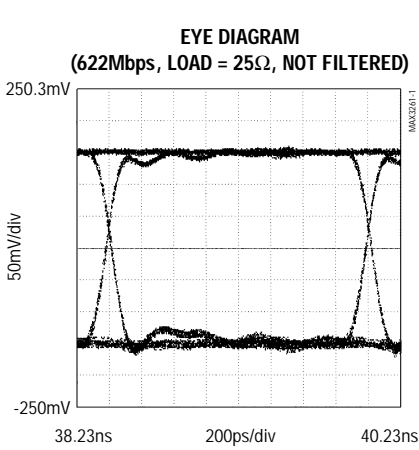

* LASER = EPITAXX EDL 1300RFC TO-STYLE HEADER

Single +5V, Fully Integrated, 1.25Gbps Laser Diode Driver

Typical Operating Characteristics (continued)

(MAX3261E/D, LOAD at OUT+ = OUT- = 25Ω, V_{CC} = V_{CCA} = V_{CCB} = +5V, T_A = +25°C, unless otherwise noted.)

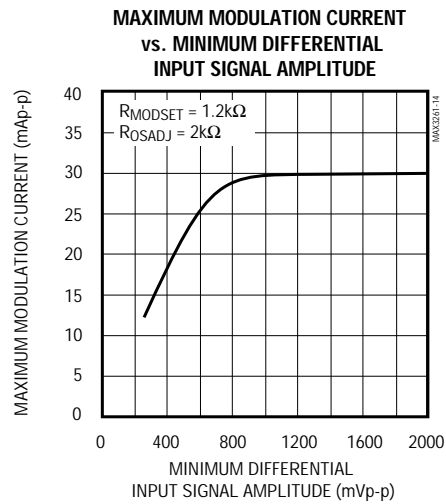
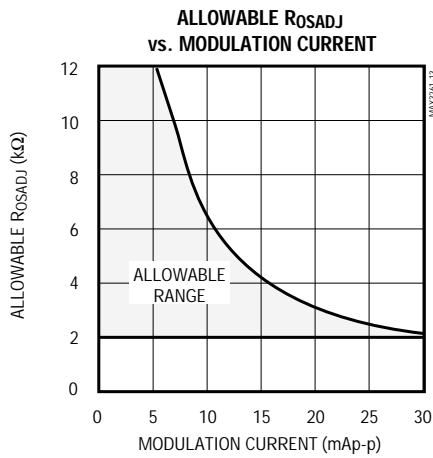
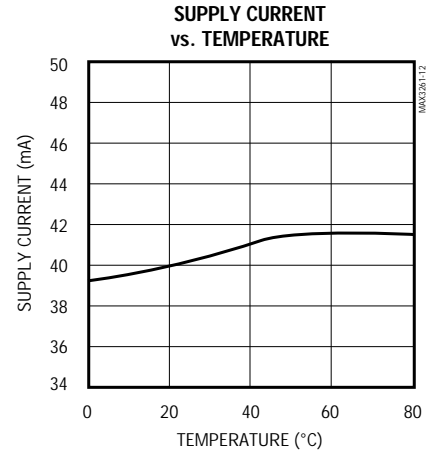
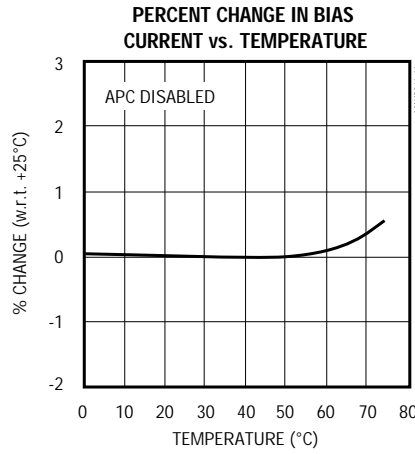
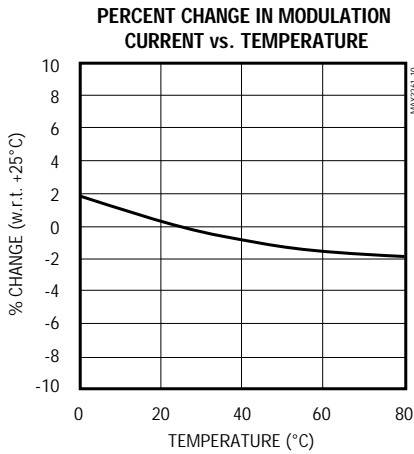

Single +5V, Fully Integrated, 1.25Gbps Laser Diode Driver

Pin Description

MAX3261

PIN	NAME	FUNCTION
1, 2, 25, 27, 29	GNDA	Ground for Bias and Modulation Current Drivers
3	IPIN	Monitor Photodiode Current Input. Connect IPIN to photodiode's anode.
4	SLWSTRT	Slow-Start Capacitor Input. Connect capacitor to ground or leave unconnected to set start-up time, $t_{STARTUP} = 25.4k\Omega (CSLWSTRT + 2pF)$.
5, 9, 11, 13	GNDB	Ground for Voltage Reference and Automatic Power-Control Circuitry
6	VREF2	Temperature-Compensated Reference Output. VREF2 is internally connected to VREF1.
7	IPINSET	Monitor Photodiode Programming Input. Connect IPINSET to VREF1 or VREF2 through a resistor to set the monitor current when using automatic power control (see <i>Typical Operating Characteristics</i>).
8	FAILOUT	Failout Output. Active-low, open-collector TTL output indicates if automatic power-control loop is out of regulation due to insufficient monitor-diode current (when V_{IPIN} is below the 2.6V threshold). Connect FAILOUT to V_{CC-} through a 2.7k Ω pull-up resistor.
10	VIN+	Noninverting PECL Data Input
12	VIN-	Inverting PECL Data Input
14, 15, 18	VCCB	+5V Supply Voltage for Voltage Reference and Automatic Power-Control Circuitry. Connect VCCB to the same potential as VCCA, but provide separate bypassing for VCCA and VCCB.
16	ENB-	Inverting Enable TTL Input. Output currents are enabled only when ENB+ is high and ENB- is low.
17	ENB+	Noninverting Enable TTL Input. Output currents are enabled only when ENB+ is high and ENB- is low.
19	VREF1	Temperature-Compensated Reference Output. VREF1 is internally connected to VREF2.
20	OSADJ	Overshoot-Adjust Input. Connect to internal voltage reference through a resistor to adjust the overshoot of the modulation output signal (see <i>Typical Operating Characteristics</i>).
21	IBIASFB	Bias-Feedback Current Output. Output from automatic power-control circuit. Connect to IBIASSET when using APC.
22	IBIASSET	Laser Bias Current-Programming Input. Connect to internal voltage reference through a resistor to set bias current (see <i>Typical Operating Characteristics</i>). $I_{BIASOUT} = 40 \times (I_{BIASSET} + I_{BIASFB})$.
23	IMODSET	Laser Modulation Current-Programming Input. Connect to internal voltage reference through a resistor to set modulation current (see <i>Typical Operating Characteristics</i>). $I_{MOD} = 20 \times I_{MODSET}$.
24	IBIASOUT	Laser Bias Current Output. Connect to laser cathode through an R-L compensation network (see the <i>Bias Network Compensation</i> section).
26	OUT-	Modulation Output. When VIN+ is high and VIN- is low, OUT- sinks I_{MOD} .
28	OUT+	Modulation Output. When VIN+ is low and VIN- is high, OUT+ sinks I_{MOD} .
30, 31, 32	VCCA	+5V Supply Voltage for Bias and Modulation Current Drivers. Connect VCCA to the same potential as VCCB, but provide separate bypassing for VCCA and VCCB.

Single +5V, Fully Integrated, 1.25Gbps Laser Diode Driver

Detailed Description

The MAX3261 laser driver has three main sections: a reference generator with temperature compensation, a laser bias block with automatic power control, and a high-speed modulation driver.

The reference generator provides temperature-compensated biasing and a voltage-reference output. The voltage reference is used to program the current levels of the high-speed modulation driver, laser diode, and PIN (p+, intrinsic, n-) monitor diode.

The laser bias block sets the bias current in the laser diode and maintains it above the threshold current. A current-controlled current source (current mirror) programs the bias, with IBIASSET as the input. The mirror's gain is approximately 40. Keep the output voltage of the bias stage above 2.2V to prevent saturation.

The modulation driver consists of a high-speed input buffer and a common-emitter differential output stage. The modulation current mirror sets the laser modulation current in the output stage. This current is switched between the OUT+ and OUT- ports of the laser driver. The modulation

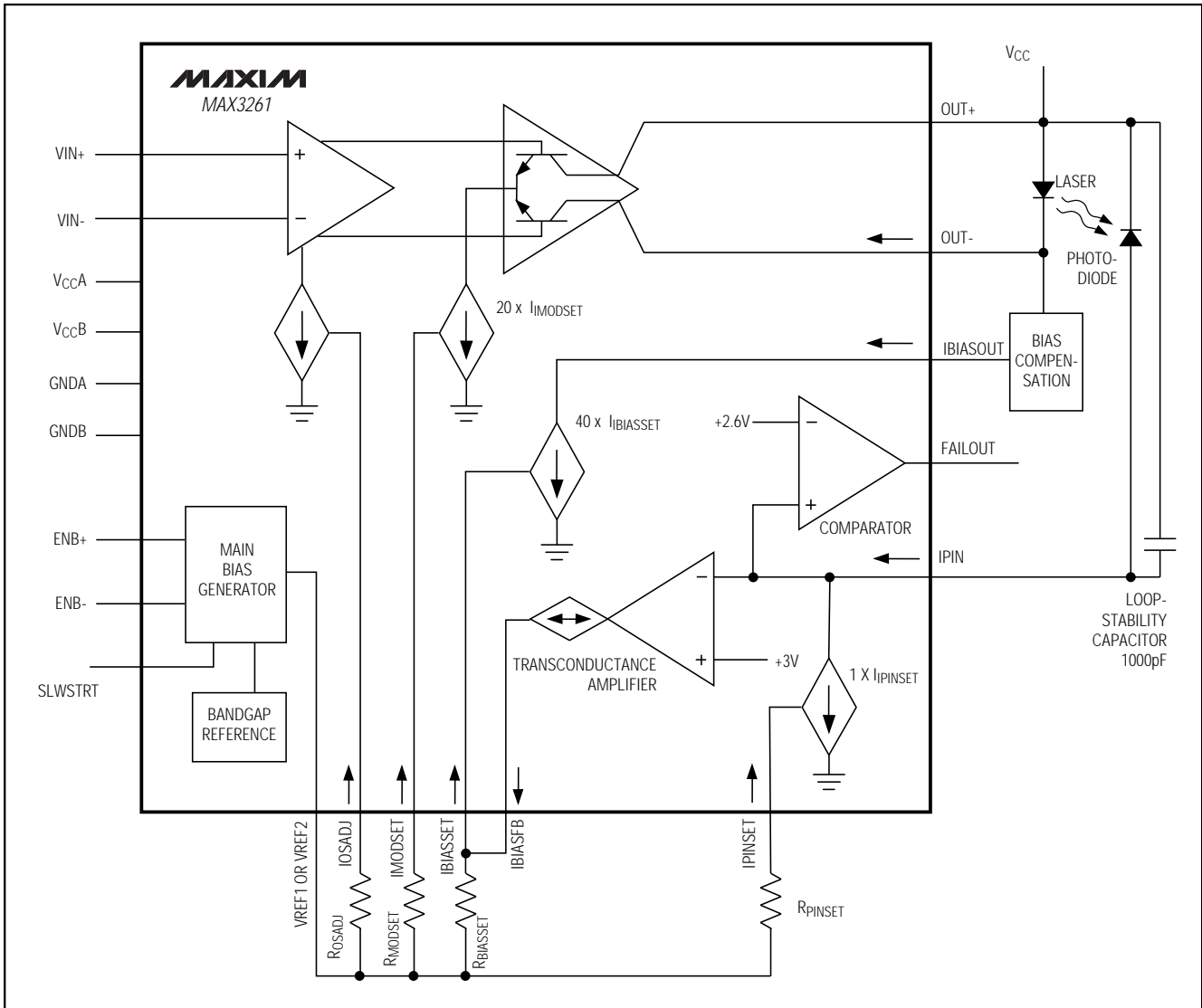

Figure 1. Functional Diagram

Single +5V, Fully Integrated, 1.25Gbps Laser Diode Driver

MAX3261

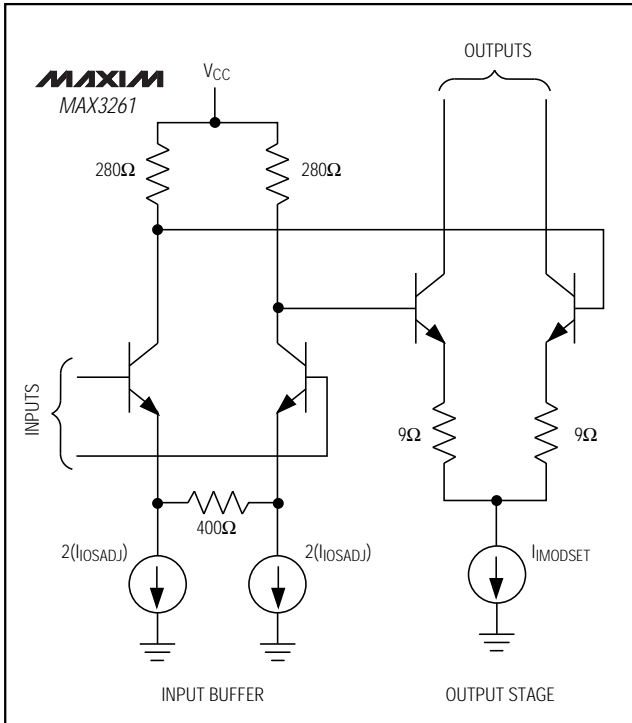

Figure 2. MAX3261 Modulation Driver (Simplified)

current mirror has a gain of approximately 20. Keep the voltages at OUT+ and OUT- above 2.2V to prevent saturation.

The overshoot mirror sets the bias in the input buffer stage (Figure 2). Reducing this current slows the input stage and reduces overshoot in the modulation signal. At the same time, the peak-to-peak output swing of the input buffer stage is reduced. Careful design must be used to ensure that the buffer stage can switch the output stage completely. The input swing required to completely switch the output stage depends on both ROSADJ and the modulation current. See Allowable ROSADJ Range vs. Modulation Current and Modulation Current vs. Differential Input Signal graphs in the *Typical Operating Characteristics*.

Failure to ensure that the output stage switches completely results in a loss of modulation current (and extinction ratio). In addition, if the modulation port does not switch completely off, the modulation current will contribute to the bias current, and may complicate module assembly.

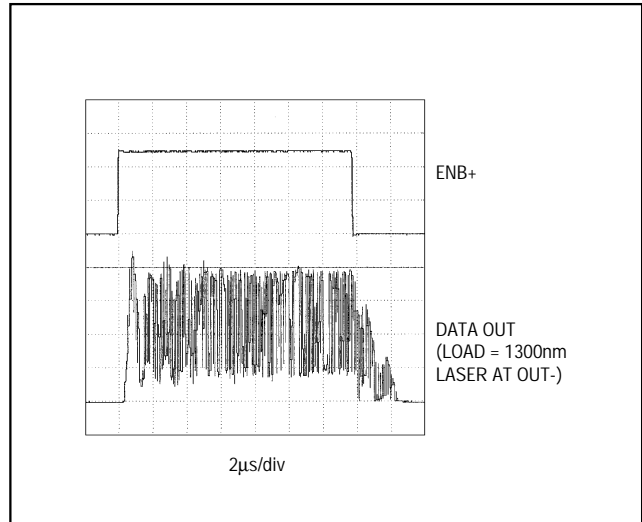

Figure 3. Enable/Disable Operation

Automatic Power Control

The automatic power control (APC) feature allows an optical transmitter to maintain constant power, despite changes in laser efficiency with temperature or age. The APC feature requires the use of a monitor photodiode.

The APC circuit incorporates the laser diode, the monitor photodiode, the PIN set current mirror, a transconductance amplifier, the bias set current mirror, and the laser fail comparator (Figure 1). Light produced by the laser diode generates an average current in the monitor photodiode. This current flows into the MAX3261's IPIN input. The PIN set current mirror draws current away from the IPIN node. When the current into the IPIN node equals the current drawn away by IPINSET, the node voltage is set by the $\frac{3}{5} \times V_{CC}$ reference of the transconductance amplifier. When the monitor current exceeds IPINSET, the IPIN node voltage will be forced higher. If the monitor current decreases, the IPIN node voltage is decreased. In either case, the voltage change is amplified by the transconductance amplifier, and results in a feedback current at the IBIASFB node. Under normal APC operation, IBIASFB is summed with IBIASSET, and the laser bias level is adjusted to maintain constant output power. This feedback process continues until the monitor-diode current equals IPINSET.

If the monitor-diode current is sufficiently less than IPINSET (i.e., the laser stops functioning), the voltage on

Single +5V, Fully Integrated, 1.25Gbps Laser Diode Driver

the IPIN node will drop below 2.6V. This will trigger the fallout comparator, which provides a TTL signal indicating laser failure. The FAILOUT output asserts only if the monitor-diode current is low, not in the reverse situation where the monitor current exceeds IPINSET. FAILOUT is an open-collector output that requires an external pull-up resistor of $2.7k\Omega$ to V_{CC} .

The transconductance amplifier can source or sink currents up to approximately 1mA. Since the laser bias generator has a gain of approximately 40, the APC function has a limit of approximately 40mA (up or down) from the initial set point. To take full advantage of this adjustment range, it may be prudent to program the laser bias current slightly higher than required for normal operation. However, do not exceed the IBIASOUT absolute maximum rating of 75mA.

To maintain APC loop stability, a 1000pF bypass capacitor may be required across the photodiode. If the APC function is not used, leave IBIASFB unconnected.

Enable Inputs

The MAX3261 provides complementary enable inputs (ENB+, ENB-) for interfacing with open-fiber-control architecture. The laser is disabled by reducing the reference voltage outputs (VREF1, VREF2). Only one logic state will enable laser operation (Table 1).

With a 1000pF stability capacitor, the MAX3261 modulation and bias can be enabled and disabled within 5 μ s (Figure 3). This timing satisfies the requirements of the Open Fiber Control system used in Fibre Channel networks.

Temperature Considerations

The MAX3261 output currents are programmed by current mirrors. These mirrors each have a $2V_{BE}$ temperature coefficient. The reference voltage (VREF) is adjusted $2V_{BE}$ so these changes largely cancel, resulting in output currents that are very stable with respect to temperature (see *Typical Operating Characteristics*).

Wire Bonding Die

For reliable operation, the MAX3261 has gold metallization. Make connections to the die with gold wire only, using ball bonding techniques. Wedge bonding is not recommended. Pad size is 4mils.

Table 1. MAX3261 Truth Table

ENB-	ENB+	OUTPUT CURRENTS
0	0	DISABLED
0	1	ENABLED
1	0	DISABLED
1	1	DISABLED

Design Procedure

Interfacing Suggestions

Use high-frequency design techniques for the board layout of the MAX3261 laser driver. High-speed interfaces often require fixed-impedance transmission lines (Figure 5). Adding some damping resistance in series with the laser raises the load impedance, making the transmission line more realizable, and it also helps reduce power consumption (see the section *Reducing Power Consumption*). Minimize any series inductance to the laser, and place a bypass capacitor as close to the laser's anode as possible.

Power connections labeled V_{CCA} are used to supply the laser modulation and laser bias circuits. V_{CCB} connections supply the bias-generator and automatic-power control circuits. For optimum operation, isolate these supplies from each other by independent bypass filtering.

V_{CCA} , V_{CCB} , $GNDA$, and $GNDB$ all have multiple pins. Connect all pins to optimize the MAX3261's high-frequency performance. Ground connections between signal lines (VIN+, VIN-, OUT+, OUT-) improve the quality of the signal path by reducing the impedance of the interconnect. Multiple connections, in general, reduce inductance in the signal path and improve the high-speed signal quality. GND pins should be tied to the ground plane with short runs and multiple vias. Avoid ground loops, since they are a source of high-frequency interference.

The MAX3261 data inputs accept PECL input signals, which require 50Ω termination to ($V_{CC} - 2V$). Figure 4 shows alternative termination techniques. When a termination voltage is not available, use the Thevenin-equivalent termination. When interfacing with a non-PECL signal source, use one of the other alternative termination methods shown in Figure 4.

Bias Network Compensation

When driving the laser diode with transmission lines, it is important to maintain a constant load impedance in order to minimize aberrations due to reflections. The inductive nature of laser packages will cause the laser impedance to increase with frequency, and the parasitic capacitance of the laser driver bias output (IBIASOUT) has some loading effects at high frequency. Of these two effects, the loading due to the laser lead inductance dominates. Impedance variation must be compensated for high-frequency operation. One possible approach is to use a shunt R-C network in parallel with the laser diode to compensate for the laser impedance (Figures 5 and 6). Add an R-L circuit in series with the bias output to compensate for the IBIASOUT capacitance (Figures 5 and 7).

Single +5V, Fully Integrated, 1.25Gbps Laser Diode Driver

MAX3261

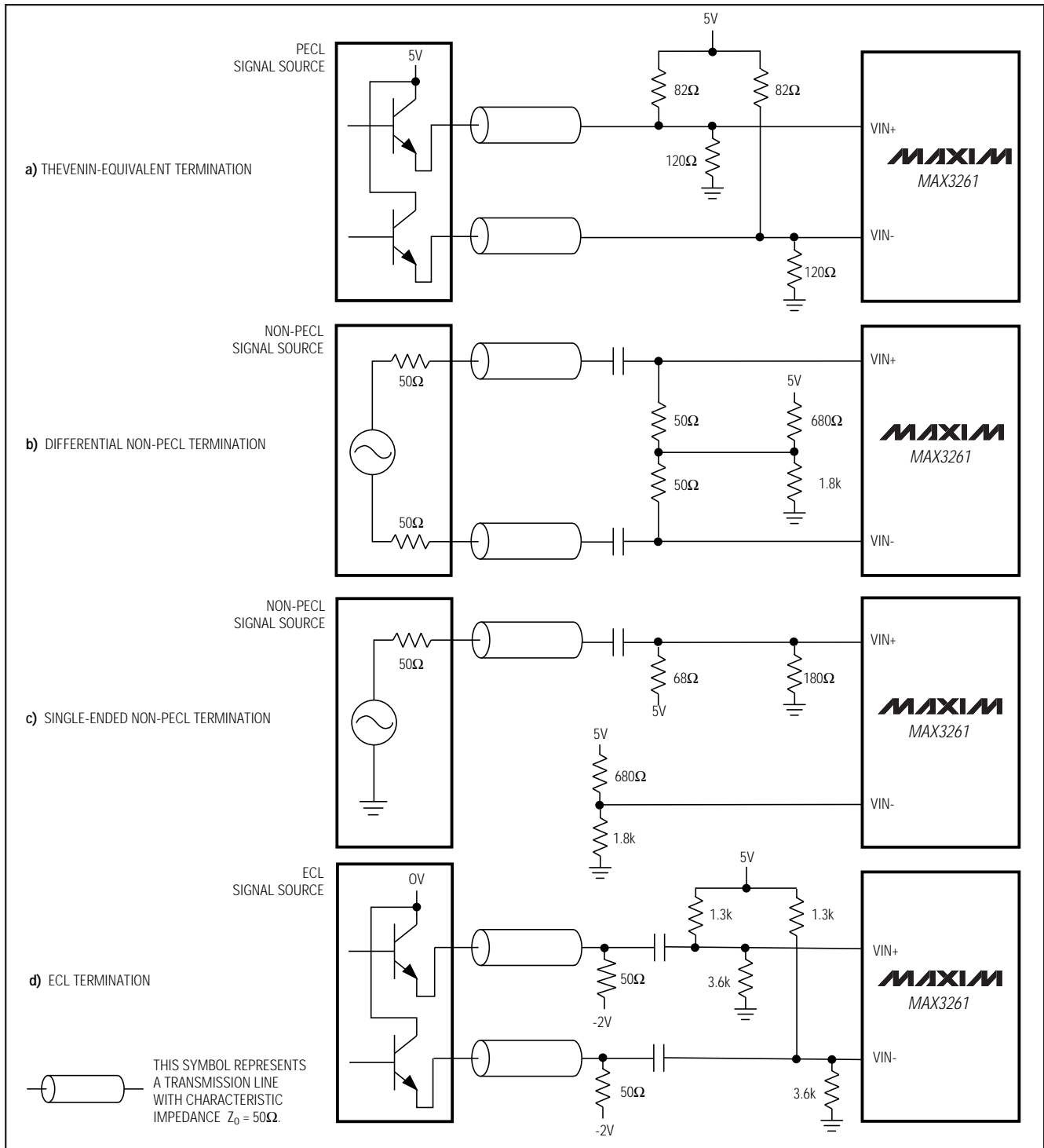

Figure 4. Alternative PECL Data-Input Terminations

Single +5V, Fully Integrated, 1.25Gbps Laser Diode Driver

Reducing Power Consumption

The laser driver typically consumes 40mA of current for internal functions. Typical load currents, such as 12mA of modulation current and 20mA of bias current, bring the total current requirement to 72mA. If this were dissipated entirely in the laser driver, it would generate 360mW of heat. Fortunately, a substantial portion of this power is dissipated across the laser diode. A typical laser diode will drop approximately 1.6V when forward biased. This leaves 3.4V at the MAX3261's OUT- terminal. It is safe to reduce the output terminal voltage even further with a series damping resistor. Terminal voltage levels down to 2.2V can be used without degrading the laser driver's high-frequency performance. Power dissipation can be further reduced by adding a series resistor on the laser driver's OUT+ side. Select the series resistor so the OUT+ terminal voltage does not drop below 2.2V with the maximum modulation current.

Applications Information

Programming the MAX3261 Laser Driver

Programming the MAX3261 is best explained by an example. Assume the following laser diode characteristics:

Wavelength	λ	780nm
Threshold Current	I_{TH}	20mA at +25°C (+0.35mA/°C temperature variation)
Monitor Responsivity	p_{non}	0.1A/W (monitor current / average optical power into the fiber)
Modulation Efficiency	η	0.1mW/mA (worst case)

Now assume the communications system has the following requirements:

Average Power	P_{AVE}	0dBm (1mW)
Extinction Ratio	E_r	6dB ($E_r = 4$)
Temperature Range	T_r	0°C to +70°C

1) Determine the value of I_{PINSET} :

The desired monitor-diode current is $(P_{AVE})(p_{non}) = (1mW)(0.1A/W) = 100\mu A$. The R_{PINSET} vs. Monitor Current graph in the *Typical Operating Characteristics* shows that R_{PINSET} should be 18k Ω .

2) Determine R_{MODSET} :

The average power is defined as $(P_1 + P_0) / 2$, where P_1 is the average amplitude of a transmitted "one" and P_0 is the average amplitude of a transmitted "zero." The extinction ratio is P_1/P_0 . Combining these

equations results in $P_1 = (2 \times P_{AVE} \times E_r) / (E_r + 1)$ and $P_0 = (2 \times P_{AVE}) / (E_r + 1)$. In this example, $P_1 = 1.6mW$ and $P_0 = 0.4mW$. The optical modulation is 1.2mW. The modulation current required to produce this output is $1.2mW / \eta = (1.2mW) / (0.1mA/mW) = 12mA$. The *Typical Operating Characteristics* show that $R_{MODSET} = 3.9k\Omega$ yields the desired modulation current.

3) Determine the value of R_{OSADJ} :

Using the Allowable R_{OSADJ} vs. Modulation Current graph in the *Typical Operating Characteristics*, a 5.6k Ω resistor is chosen for 12mA of modulation current. The maximum R_{OSADJ} values given in the graph minimize aberrations in the waveform and ensure that the driver stage operates fully limited.

4) Determine the value of $R_{BIASSET}$:

The automatic power control circuit can adjust the bias current 40mA from the initial setpoint. This feature makes the laser driver circuit reasonably insensitive to variations of laser threshold from lot to lot. The bias setting can be determined using one of two methods:

- Set the bias at the laser threshold.
- Set the bias at the midpoint of the highest and lowest expected threshold values.

Method A is straightforward. In the second method, it is assumed that the laser threshold will increase with age. The lowest threshold current occurs at 0°C, when the laser is new. The highest threshold current occurs at +70°C, at the end of the product's life. Assume the laser is near the end of life when its threshold reaches two-times its original value.

Lowest Bias Current:

$$I_{TH} + \Delta T_{TH} = 20mA + (0.35mA/°C)(-25°C) = 11.25mA$$

Highest Bias Current:

$$2 \times I_{TH} + \Delta T_{TH} = 40mA + (0.35mA/°C)(+45°C) = 55.8mA$$

In this case, set the initial bias value to 34mA (which is the midpoint of the two extremes). The adjustment range of the MAX3261 maintains the average laser power at either extreme.

The *Typical Operating Characteristics* show that $R_{BIASSET} = 1.8k\Omega$ delivers the required bias current.

Single +5V, Fully Integrated, 1.25Gbps Laser Diode Driver

MAX3261

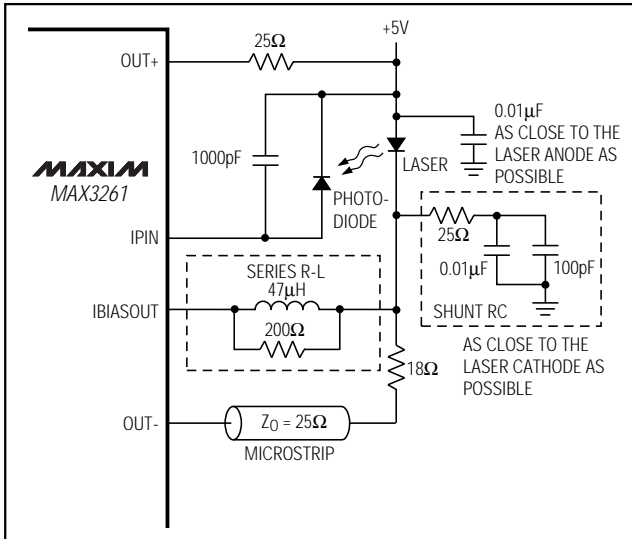

Figure 5. Typical Laser Interface with Bias Compensation

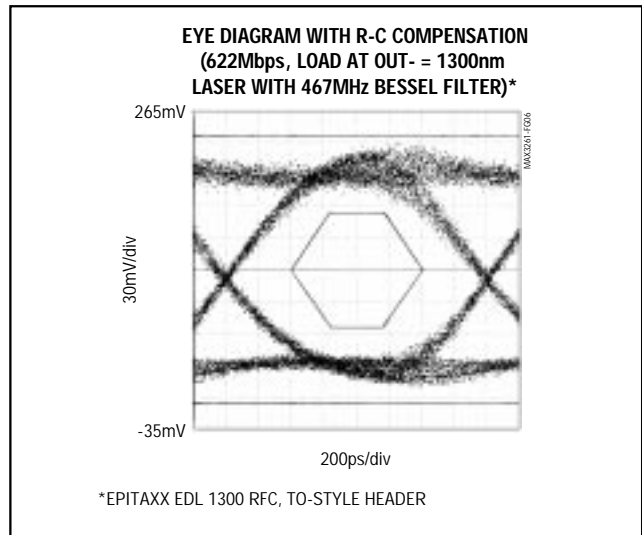

Figure 6. Eye Diagram with R-C Compensation (LOAD at OUT- = 1300nm Laser)

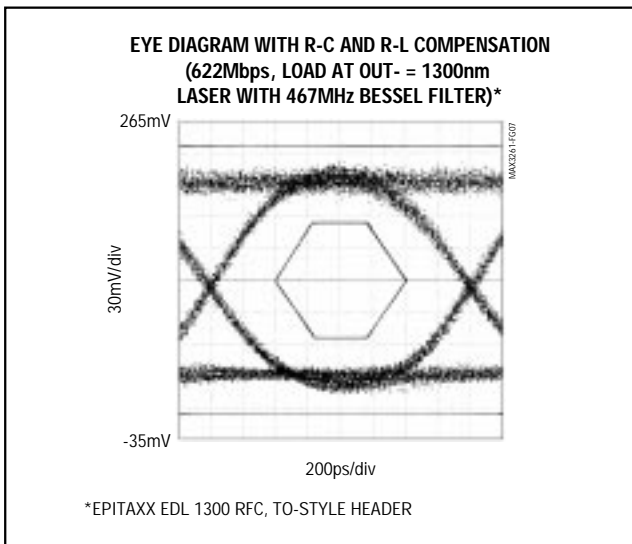

Figure 7. Eye Diagram with R-C and R-L Compensation (LOAD at OUT- = 1300nm Laser)

Laser Safety and IEC 825

Using the MAX3261 laser driver alone does not ensure that a transmitter design is compliant with IEC 825. The entire transmitter circuit and component selections must be considered. Each customer must determine the level of fault tolerance required by their application, recognizing that Maxim products are not designed or authorized for use as components in systems intended for surgical implant into the body, for applications intended to support or sustain life, or for any other application where the failure of a Maxim product could create a situation where personal injury or death may occur.

Single +5V, Fully Integrated, 1.25Gbps Laser Diode Driver

Chip Topography

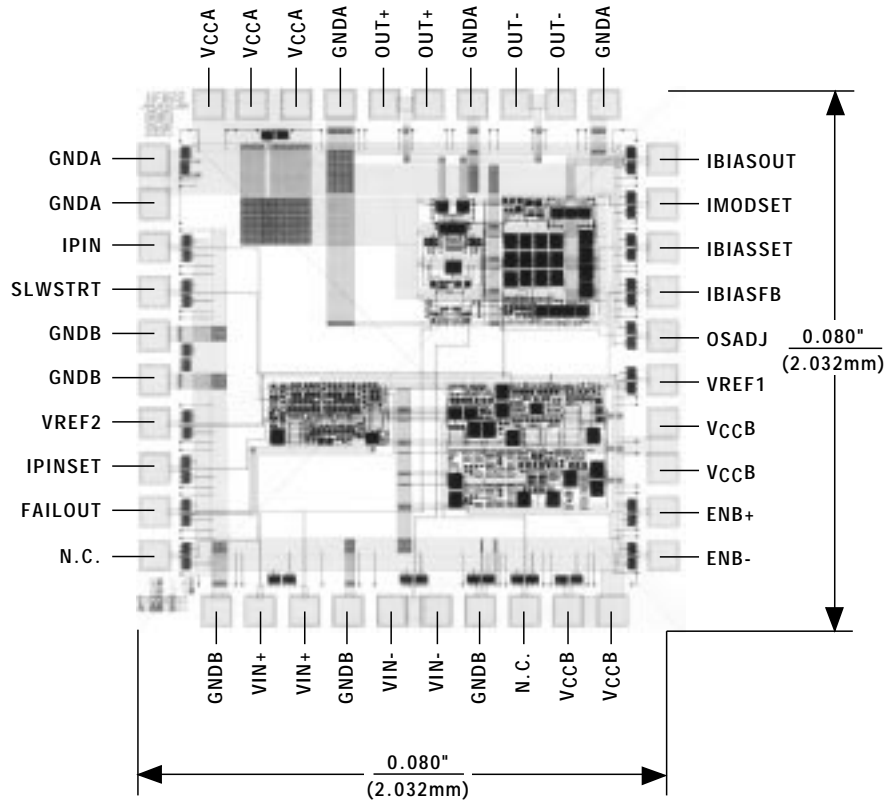

TRANSISTOR COUNT: 197
SUBSTRATE CONNECTED TO GNDA AND GNDB

Maxim makes no warranty, representation or guarantee regarding the suitability of its products for any particular purpose, nor does Maxim assume any liability arising out of the application or use of any product or circuit and specifically disclaims any and all liability, without limitation, consequential or incidental damages. "Typical" parameters can and do vary in different applications. All operating parameters, including "typicals" must be validated for each customer application by customer's technical experts. Maxim products are not designed, intended or authorized for use as components in systems intended for surgical implant into the body, or for other applications intended to support or sustain life, or for any other application in which the failure of the Maxim product could create a situation where personal injury or death may occur.

Maxim cannot assume responsibility for use of any circuitry other than circuitry entirely embodied in a Maxim product. No circuit patent licenses are implied. Maxim reserves the right to change the circuitry and specifications without notice at any time.

12 Maxim Integrated Products, 120 San Gabriel Drive, Sunnyvale, CA 94086 408-737-7600