

IS61LV25616AL

256K x 16 HIGH SPEED ASYNCHRONOUS CMOS STATIC RAM WITH 3.3V SUPPLY

FEBRUARY 2003

FEATURES

- High-speed access time:
 - 10, 12 ns
- CMOS low power operation
- Low stand-by power:
 - Less than 5 mA (typ.) CMOS stand-by
- TTL compatible interface levels
- Single 3.3V power supply
- Fully static operation: no clock or refresh required
- Three state outputs
- Data control for upper and lower bytes
- Industrial temperature available

DESCRIPTION

The *ISSI* IS61LV25616AL is a high-speed, 4,194,304-bit static RAM organized as 262,144 words by 16 bits. It is fabricated using *ISSI*'s high-performance CMOS technology. This highly reliable process coupled with innovative circuit design techniques, yields high-performance and low power consumption devices.

When \overline{CE} is HIGH (deselected), the device assumes a standby mode at which the power dissipation can be reduced down with CMOS input levels.

Easy memory expansion is provided by using Chip Enable and Output Enable inputs, \overline{CE} and \overline{OE} . The active LOW Write Enable (\overline{WE}) controls both writing and reading of the memory. A data byte allows Upper Byte (\overline{UB}) and Lower Byte (\overline{LB}) access.

The IS61LV25616AL is packaged in the JEDEC standard 44-pin 400-mil SOJ, 44-pin TSOP Type II, 44-pin LQFP and 48-pin Mini BGA (8mm x 10mm).

FUNCTIONAL BLOCK DIAGRAM

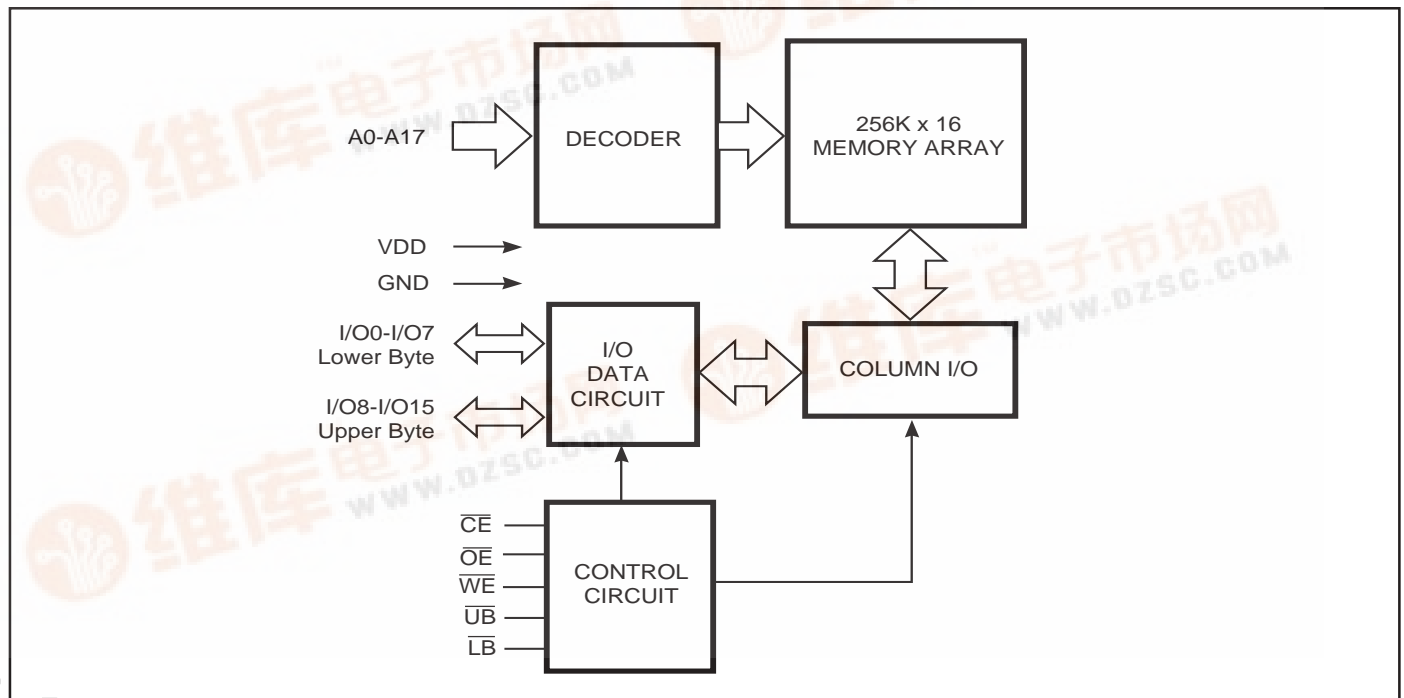

TRUTH TABLE

Mode	\overline{WE}	\overline{CE}	\overline{OE}	\overline{LB}	\overline{UB}	I/O PIN		V _{DD} Current
						I/O0-I/O7	I/O8-I/O15	
Not Selected	X	H	X	X	X	High-Z	High-Z	I _{SB1} , I _{SB2}
Output Disabled	H	L	H	X	X	High-Z	High-Z	I _{CC}
	X	L	X	H	H	High-Z	High-Z	
Read	H	L	L	L	H	DOUT	High-Z	I _{CC}
	H	L	L	H	L	High-Z	DOUT	
	H	L	L	L	L	DOUT	DOUT	
Write	L	L	X	L	H	DIN	High-Z	I _{CC}
	L	L	X	H	L	High-Z	DIN	
	L	L	X	L	L	DIN	DIN	

PIN CONFIGURATIONS

44-Pin TSOP (Type II) and SOJ

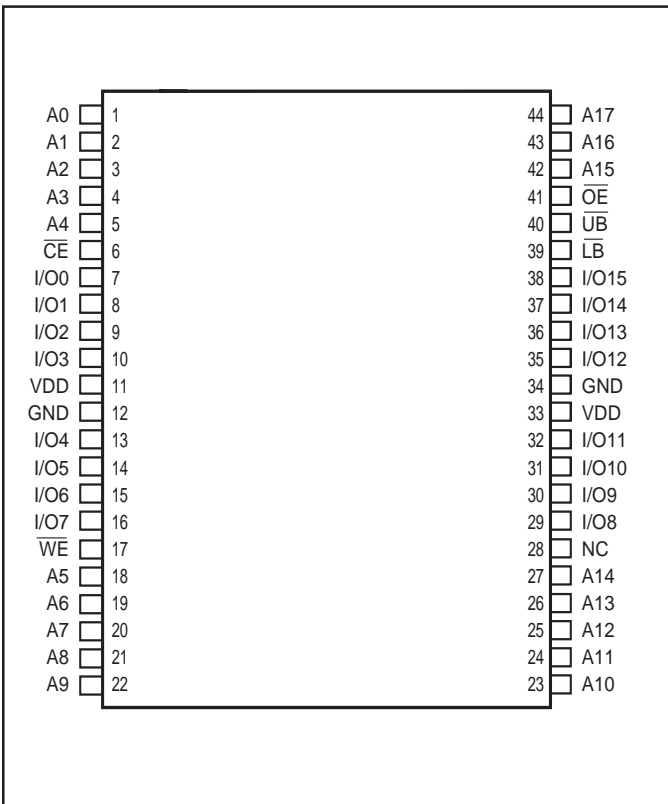

PIN DESCRIPTIONS

A0-A17	Address Inputs
I/O0-I/O15	Data Inputs/Outputs
\overline{CE}	Chip Enable Input
\overline{OE}	Output Enable Input
\overline{WE}	Write Enable Input
\overline{LB}	Lower-byte Control (I/O0-I/O7)
\overline{UB}	Upper-byte Control (I/O8-I/O15)
NC	No Connection
V _{DD}	Power
GND	Ground

PIN CONFIGURATIONS

44-Pin LQFP

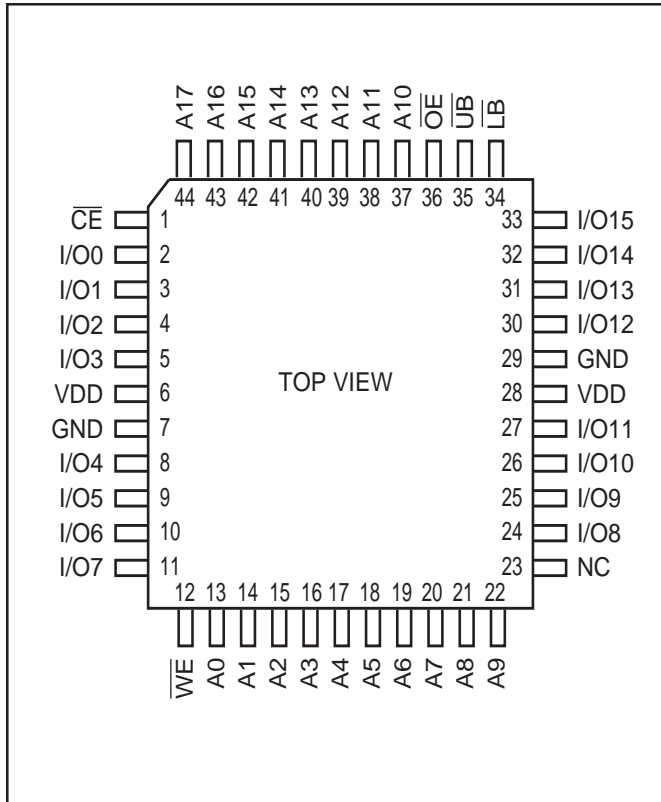

48-Pin mini BGA

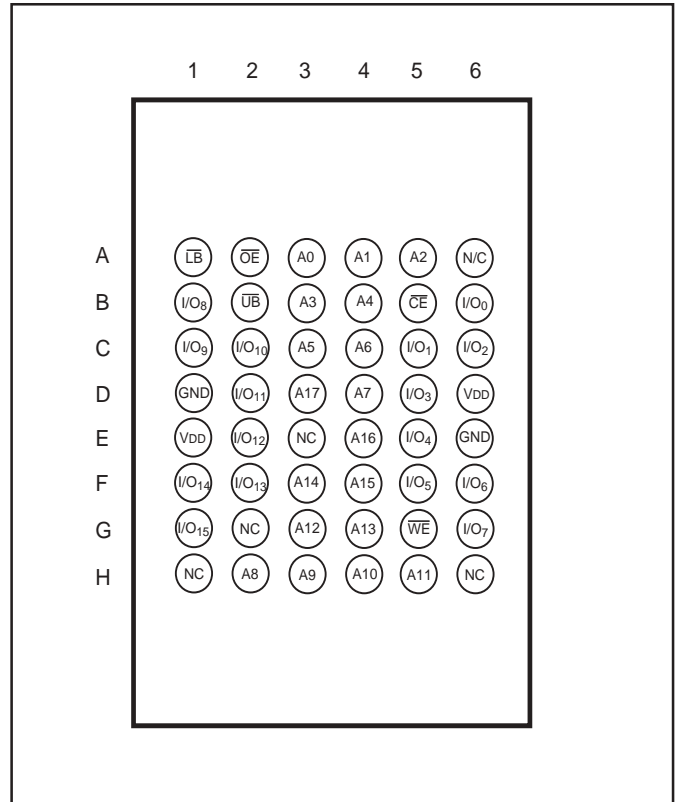

PIN DESCRIPTIONS

A0-A17	Address Inputs
I/O0-I/O15	Data Inputs/Outputs
\overline{CE}	Chip Enable Input
\overline{OE}	Output Enable Input
\overline{WE}	Write Enable Input
\overline{LB}	Lower-byte Control (I/O0-I/O7)
\overline{UB}	Upper-byte Control (I/O8-I/O15)
NC	No Connection
VDD	Power
GND	Ground

ABSOLUTE MAXIMUM RATINGS⁽¹⁾

Symbol	Parameter	Value	Unit
V _{TERM}	Terminal Voltage with Respect to GND	-0.5 to V _{DD} +0.5	V
T _{STG}	Storage Temperature	-65 to +150	°C
P _T	Power Dissipation	1.0	W

Note:

1. Stress greater than those listed under ABSOLUTE MAXIMUM RATINGS may cause permanent damage to the device. This is a stress rating only and functional operation of the device at these or any other conditions above those indicated in the operational sections of this specification is not implied. Exposure to absolute maximum rating conditions for extended periods may affect reliability.

OPERATING RANGE

Range	Ambient Temperature	V _{DD}	
		10ns	12ns
Commercial	0°C to +70°C	3.3V +10%, -5%	3.3V ± 10%
Industrial	-40°C to +85°C	3.3V +10%, -5%	3.3V ± 10%

DC ELECTRICAL CHARACTERISTICS (Over Operating Range)

Symbol	Parameter	Test Conditions	Min.	Max.	Unit
V _{OH}	Output HIGH Voltage	V _{DD} = Min., I _{OH} = -4.0 mA	2.4	—	V
V _{OL}	Output LOW Voltage	V _{DD} = Min., I _{OL} = 8.0 mA	—	0.4	V
V _{IH}	Input HIGH Voltage		2.0	V _{DD} + 0.3	V
V _{IL}	Input LOW Voltage ⁽¹⁾		-0.3	0.8	V
I _{LI}	Input Leakage	GND ≤ V _{IN} ≤ V _{DD}	Com. Ind.	-2 5	μA
I _{LO}	Output Leakage	GND ≤ V _{OUT} ≤ V _{DD} Outputs Disabled	Com. Ind.	-2 5	μA

Notes:

1. V_{IL} (min.) = -2.0V for pulse width less than 10 ns.

POWER SUPPLY CHARACTERISTICS⁽¹⁾ (Over Operating Range)

Symbol	Parameter	Test Conditions	-10		-12		Unit	
			Min.	Max.	Min.	Max.		
I _{CC}	V _{DD} Dynamic Operating Supply Current	V _{DD} = Max.,	Com.	—	100	—	90	mA
		I _{OUT} = 0 mA, f = f _{MAX}	Ind.	—	110	—	100	
I _{SB}	TTL Standby Current (TTL Inputs)	V _{DD} = Max.,	Com.	—	50	—	45	mA
		V _{IN} = V _{IH} or V _{IL} CE ≥ V _{IH} , f = f _{MAX} .	Ind.	—	55	—	50	
I _{SB1}	TTL Standby Current (TTL Inputs)	V _{DD} = Max.,	Com.	—	20	—	20	mA
		V _{IN} = V _{IH} or V _{IL} CE ≥ V _{IH} , f = 0	Ind.	—	25	—	25	
I _{SB2}	CMOS Standby Current (CMOS Inputs)	V _{DD} = Max.,	Com.	—	15	—	15	mA
		CE ≥ V _{DD} - 0.2V, V _{IN} ≥ V _{DD} - 0.2V, or V _{IN} ≤ 0.2V, f = 0	Ind.	—	20	—	20	

Note:

1. At f = f_{MAX}, address and data inputs are cycling at the maximum frequency, f = 0 means no input lines change. Shaded area product in development

CAPACITANCE⁽¹⁾

Symbol	Parameter	Conditions	Max.	Unit
C _{IN}	Input Capacitance	V _{IN} = 0V	6	pF
C _{OUT}	Input/Output Capacitance	V _{OUT} = 0V	8	pF

Note:

1. Tested initially and after any design or process changes that may affect these parameters.

READ CYCLE SWITCHING CHARACTERISTICS⁽¹⁾ (Over Operating Range)

Symbol	Parameter	-10		-12		Unit
		Min.	Max.	Min.	Max.	
t _{RC}	Read Cycle Time	10	—	12	—	ns
t _{AA}	Address Access Time	—	10	—	12	ns
t _{OHA}	Output Hold Time	2	—	2	—	ns
t _{ACE}	\overline{CE} Access Time	—	10	—	12	ns
t _{DOE}	\overline{OE} Access Time	—	4	—	5	ns
t _{HZOE⁽²⁾}	\overline{OE} to High-Z Output	—	4	—	5	ns
t _{LZOE⁽²⁾}	\overline{OE} to Low-Z Output	0	—	0	—	ns
t _{HZCE⁽²⁾}	\overline{CE} to High-Z Output	0	4	0	6	ns
t _{LZCE⁽²⁾}	\overline{CE} to Low-Z Output	3	—	3	—	ns
t _{BA}	\overline{LB} , \overline{UB} Access Time	—	4	—	5	ns
t _{HZB⁽²⁾}	\overline{LB} , \overline{UB} to High-Z Output	0	3	0	4	ns
t _{LZB⁽²⁾}	\overline{LB} , \overline{UB} to Low-Z Output	0	—	0	—	ns
t _{PU}	Power Up Time	0	—	0	—	ns
t _{PD}	Power Down Time	—	10	—	12	ns

Notes:

1. Test conditions assume signal transition times of 3 ns or less, timing reference levels of 1.5V, input pulse levels of 0V to 3.0V and output loading specified in Figure 1.
2. Tested with the load in Figure 2. Transition is measured ±500 mV from steady-state voltage.

AC TEST LOADS

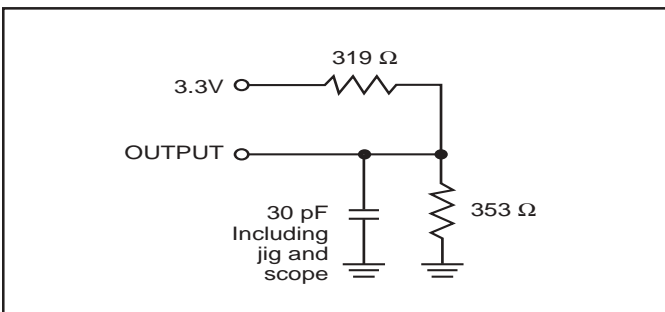

Figure 1

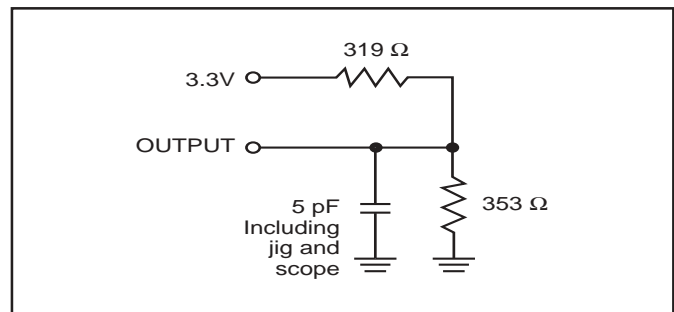

Figure 2

AC TEST CONDITIONS

Parameter	Unit
Input Pulse Level	0V to 3.0V
Input Rise and Fall Times	3 ns
Input and Output Timing and Reference Level	1.5V
Output Load	See Figures 1 and 2

AC WAVEFORMS

READ CYCLE NO. 1^(1,2) (Address Controlled) ($\overline{CE} = \overline{OE} = V_{IL}$, \overline{UB} or $\overline{LB} = V_{IL}$)

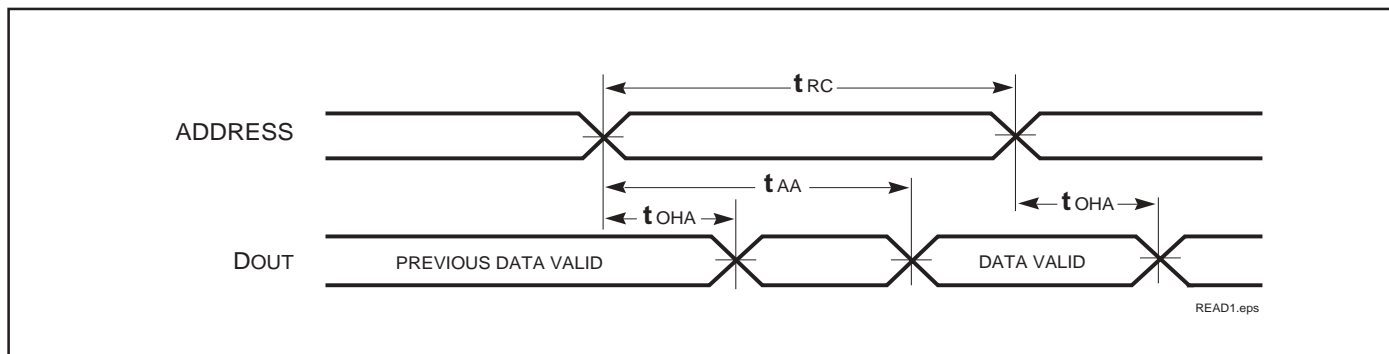

READ CYCLE NO. 2^(1,3)

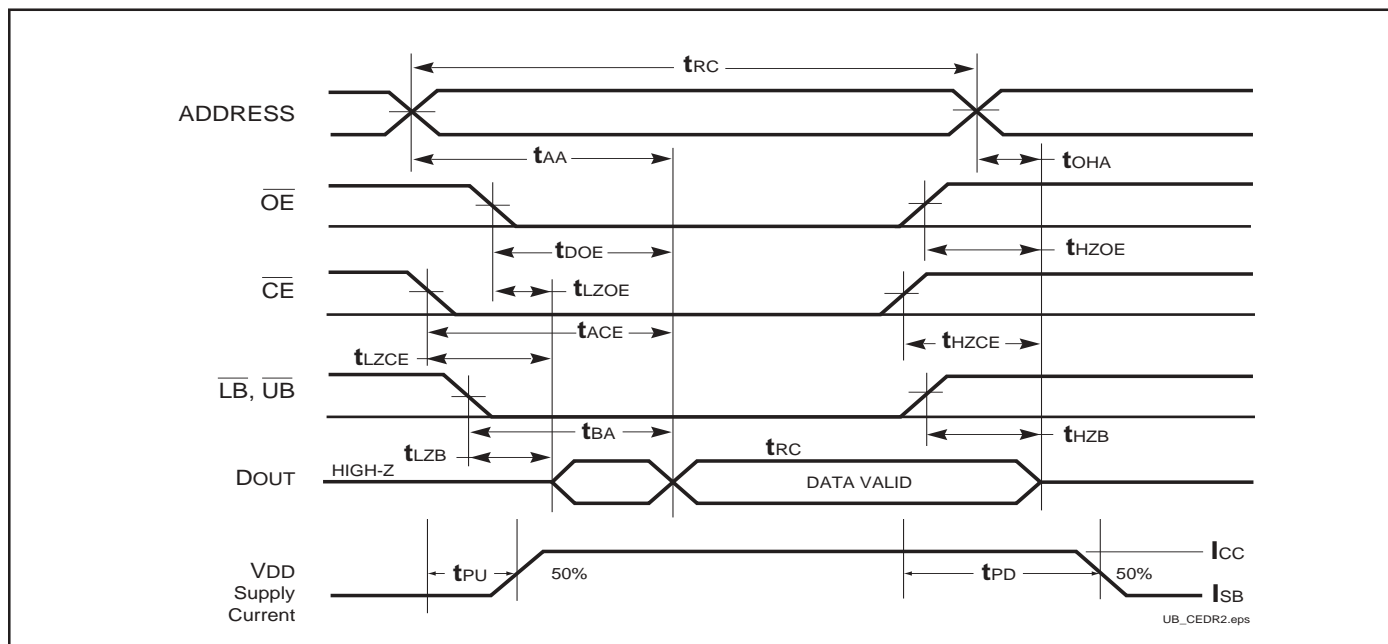

Notes:

1. \overline{WE} is HIGH for a Read Cycle.
2. The device is continuously selected. \overline{OE} , \overline{CE} , \overline{UB} , or $\overline{LB} = V_{IL}$.
3. Address is valid prior to or coincident with \overline{CE} LOW transition.

READ CYCLE NO. 2^(1,3)

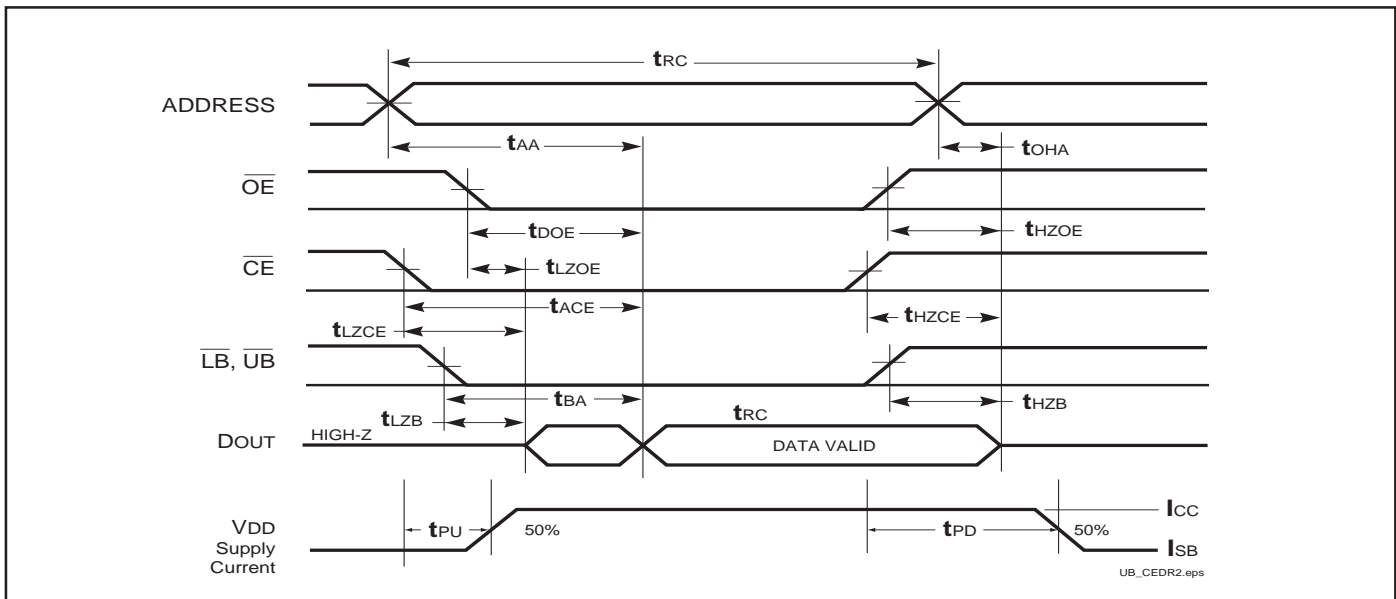

Notes:

1. \overline{WE} is HIGH for a Read Cycle.
2. The device is continuously selected. \overline{OE} , \overline{CE} , \overline{UB} , or $\overline{LB} = V_{IL}$.
3. Address is valid prior to or coincident with \overline{CE} LOW transition.

WRITE CYCLE SWITCHING CHARACTERISTICS^(1,3) (Over Operating Range)

Symbol	Parameter	-10		-12		Unit
		Min.	Max.	Min.	Max.	
t _{WC}	Write Cycle Time	10	—	12	—	ns
t _{SCE}	\overline{CE} to Write End	8	—	8	—	ns
t _{AW}	Address Setup Time to Write End	8	—	8	—	ns
t _{HA}	Address Hold from Write End	0	—	0	—	ns
t _{SA}	Address Setup Time	0	—	0	—	ns
t _{PWB}	\overline{LB} , \overline{UB} Valid to End of Write	8	—	8	—	ns
t _{PWE1}	\overline{WE} Pulse Width	8	—	8	—	ns
t _{PWE2}	\overline{WE} Pulse Width ($\overline{OE} = \text{LOW}$)	10	—	12	—	ns
t _{SD}	Data Setup to Write End	6	—	6	—	ns
t _{HD}	Data Hold from Write End	0	—	0	—	ns
t _{HZWE} ⁽²⁾	\overline{WE} LOW to High-Z Output	—	5	—	6	ns
t _{LZWE} ⁽²⁾	\overline{WE} HIGH to Low-Z Output	2	—	2	—	ns

Notes:

1. Test conditions assume signal transition times of 3 ns or less, timing reference levels of 1.5V, input pulse levels of 0V to 3.0V and output loading specified in Figure 1.
2. Tested with the load in Figure 2. Transition is measured ± 500 mV from steady-state voltage. Not 100% tested.
3. The internal write time is defined by the overlap of \overline{CE} LOW and \overline{UB} or \overline{LB} and \overline{WE} LOW. All signals must be in valid states to initiate a Write, but any one can go inactive to terminate the Write. The Data Input Setup and Hold timing are referenced to the rising or falling edge of the signal that terminates the write.

AC WAVEFORMS

WRITE CYCLE NO. 1 (\overline{CE} Controlled, \overline{OE} is HIGH or LOW) ⁽¹⁾

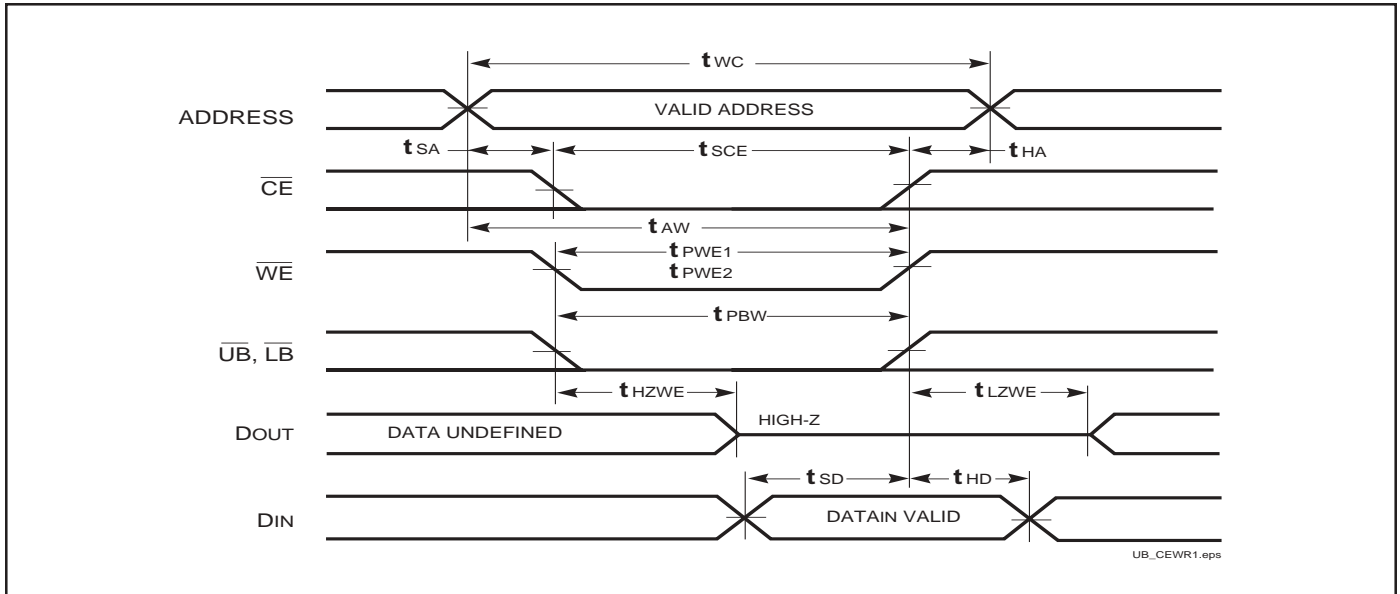

Notes:

1. WRITE is an internally generated signal asserted during an overlap of the LOW states on the \overline{CE} and \overline{WE} inputs and at least one of the \overline{LB} and \overline{UB} inputs being in the LOW state.
2. $WRITE = (\overline{CE}) [(\overline{LB}) = (\overline{UB})] (\overline{WE})$.

WRITE CYCLE NO. 2 (\overline{WE} Controlled. \overline{OE} is HIGH During Write Cycle) ^(1,2)

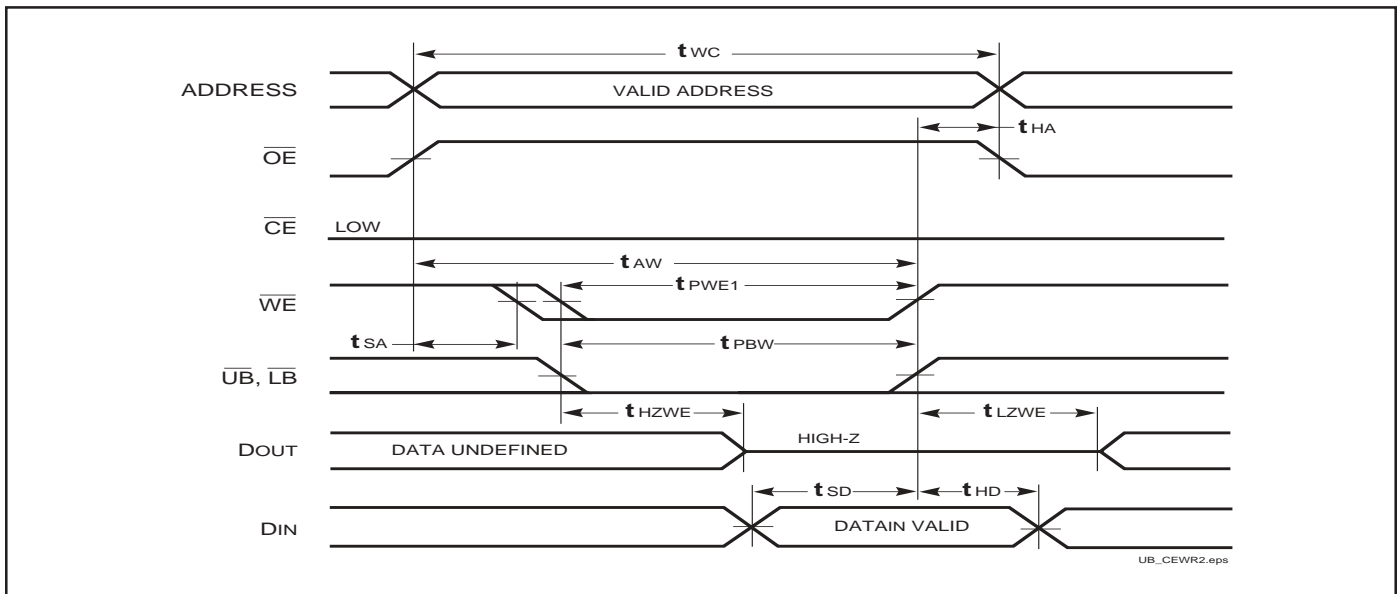

AC WAVEFORMS

WRITE CYCLE NO. 3 (\overline{WE} Controlled, \overline{OE} is LOW During Write Cycle) ⁽¹⁾

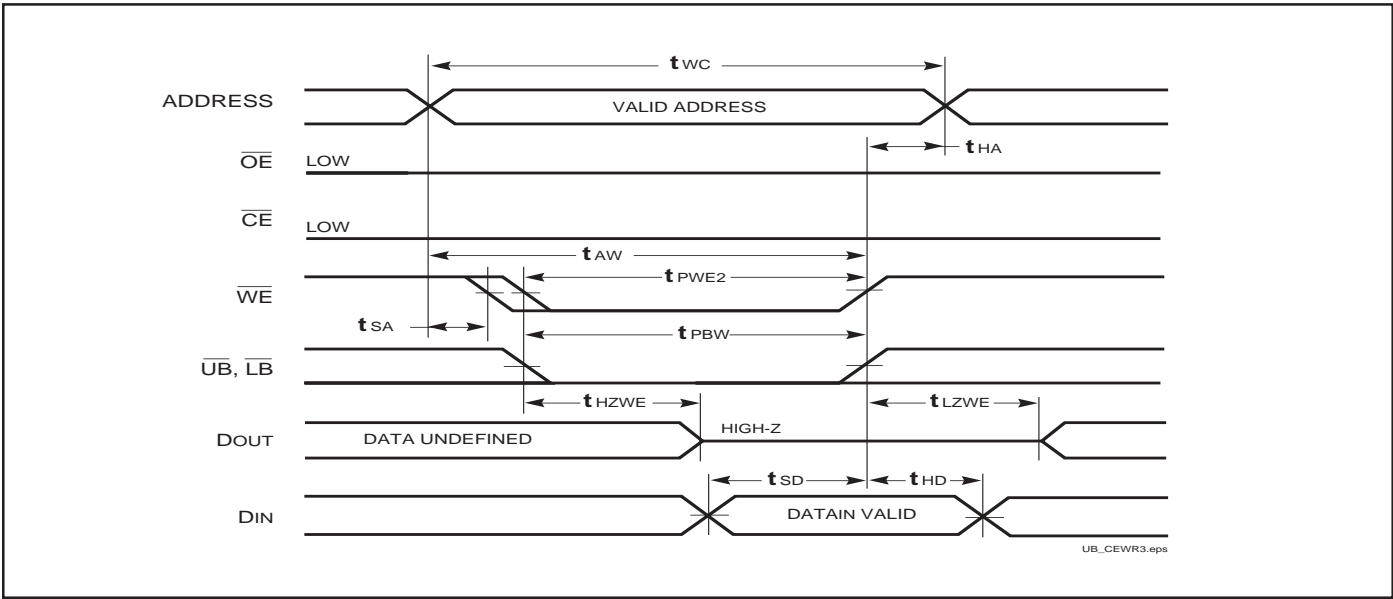

WRITE CYCLE NO. 4 (\overline{LB} , \overline{UB} Controlled, Back-to-Back Write) ^(1,3)

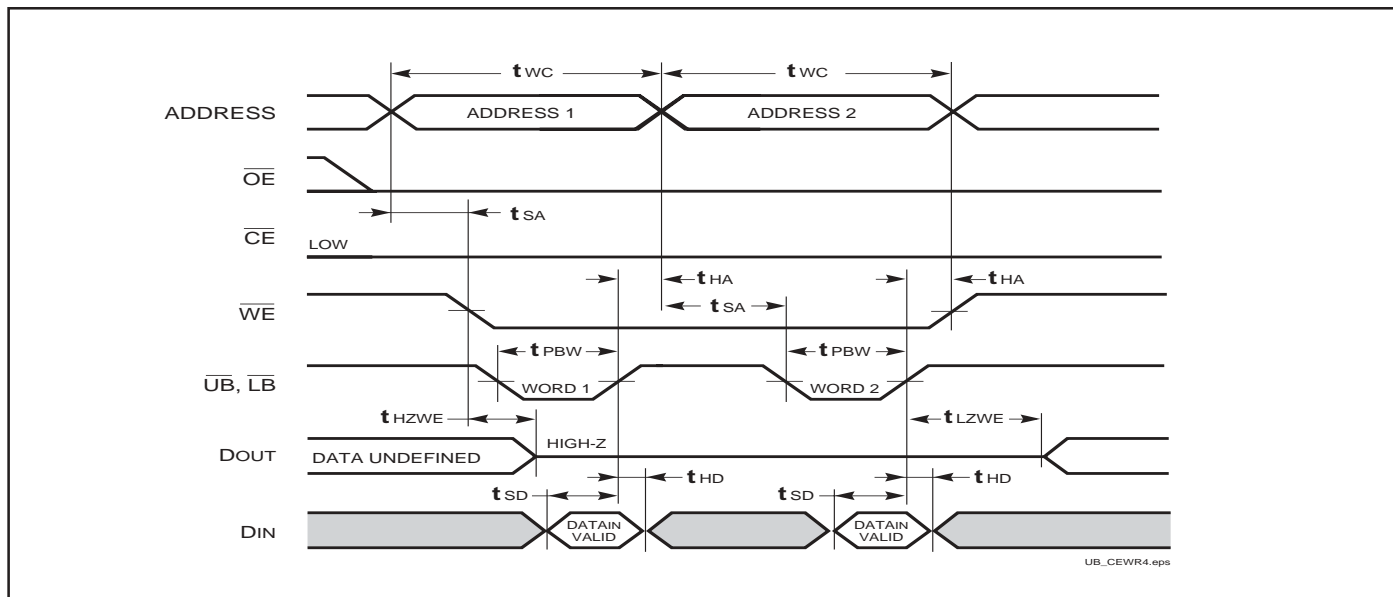

Notes:

1. The internal Write time is defined by the overlap of $\overline{CE} = \text{LOW}$, \overline{UB} and/or $\overline{LB} = \text{LOW}$, and $\overline{WE} = \text{LOW}$. All signals must be in valid states to initiate a Write, but any can be deasserted to terminate the Write. The t_{SA} , t_{HA} , t_{SD} , and t_{HD} timing is referenced to the rising or falling edge of the signal that terminates the Write.
2. Tested with \overline{OE} HIGH for a minimum of 4 ns before $\overline{WE} = \text{LOW}$ to place the I/O in a HIGH-Z state.
3. \overline{WE} may be held LOW across many address cycles and the \overline{LB} , \overline{UB} pins can be used to control the Write function.

DATA RETENTION SWITCHING CHARACTERISTICS (LL)

Symbol	Parameter	Test Condition	Options	Min.	Typ. ⁽¹⁾	Max.	Unit
V _{DR}	V _{DD} for Data Retention	See Data Retention Waveform		2.0	—	3.6	V
I _{DR}	Data Retention Current	V _{DD} = 2.0V, $\overline{CE} \geq V_{DD} - 0.2V$	Com. Ind.	— —	5 —	10 15	mA
t _{SDR}	Data Retention Setup Time	See Data Retention Waveform		0	—	—	ns
t _{RDR}	Recovery Time	See Data Retention Waveform		t _{rc}	—	—	ns

Note 1: Typical values are measured at V_{DD} = 3.0V, T_A = 25°C and not 100% tested.

DATA RETENTION WAVEFORM (\overline{CE} Controlled)

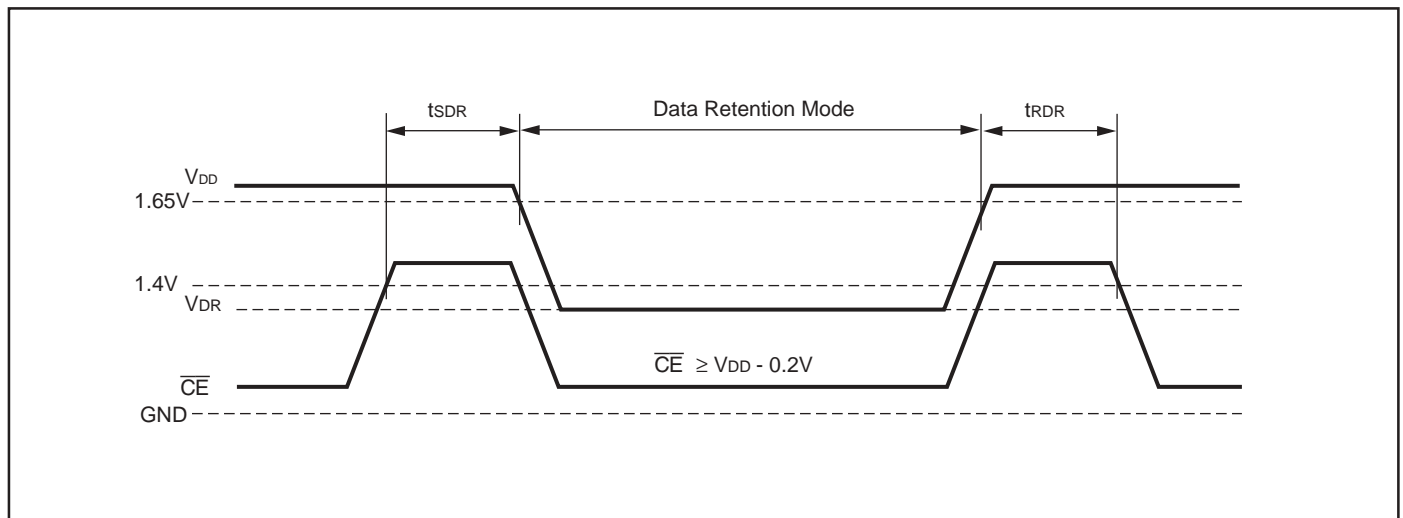

ORDERING INFORMATION**Commercial Range: 0°C to +70°C**

Speed (ns)	Order Part No.	Package
10	IS61LV25616AL-10T	TSOP (Type II)
	IS61LV25616AL-10K	400-mil SOJ
	IS61LV25616AL-10LQ	LQFP
	IS61LV25616AL-10B	Mini BGA (8mm x 10mm)
12	IS61LV25616AL-12T	TSOP (Type II)
	IS61LV25616AL-12K	400-mil SOJ
	IS61LV25616AL-12B	Mini BGA (8mm x 10mm)

Industrial Range: -40°C to +85°C

Speed (ns)	Order Part No.	Package
10	IS61LV25616AL-10TI	TSOP (Type II)
	IS61LV25616AL-10KI	400-mil SOJ
	IS61LV25616AL-10LQI	LQFP
	IS61LV25616AL-10BI	Mini BGA (8mm x 10mm)
12	IS61LV25616AL-12TI	TSOP (Type II)
	IS61LV25616AL-12KI	400-mil SOJ