

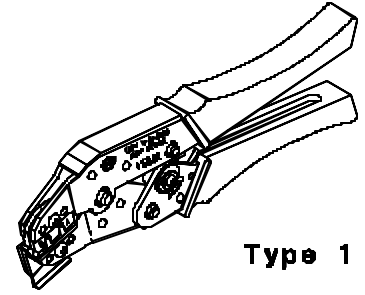

TOOLING SPECIFICATION SHEET HAND CRIMP TOOL Part No. 63811-2300



Type 1

SCOPE

Terminal Series No	Wire Size		Insulation Diameter		Strip Length	
	Awg	mm ²	mm	in	mm	in
2578	22-26	0.35-0.12	1.20-1.52	.047-.060	2.54-3.17	.100-.125
5168	22-26	0.35-0.12	1.20-1.52	.047-.060	2.54-3.17	.100-.125
7258	22-26	0.35-0.12	1.20-1.52	.047-.060	2.54-3.17	.100-.125

CONDITIONS:

After crimping, the conductor profile should measure the following: (see notes).

Terminal Series No.	Wire Size		Crimp Height (Ref.)		Pull Force Min.		Punch Width Ref.		Profile	
	Awg	mm ²	mm	in	N	Lbs.	mm	Ins.	A	B
2578	22	0.35	.94-1.04	.037-.041	44.5	10.00	1.56	1.94	X	
2578	24	0.20	.84-.94	.033-.037	35.6	8.00	1.56	1.56		X
2578	26	0.12	.84-.94	.033-.037	26.7	6.00	1.56	1.56		X
5168	22	0.35	.94-1.04	.037-.041	44.5	10.00	1.56	1.94	X	
5168	24	0.20	.84-.94	.033-.037	35.6	8.00	1.56	1.56		X
5168	26	0.12	.84-.94	.033-.037	26.7	6.00	1.56	1.56		X
7258	22	0.35	.94-1.04	.037-.041	44.5	10.00	1.56	1.94	X	
7258	24	0.20	.84-.94	.033-.037	35.6	8.00	1.56	1.56		X
7258	26	0.12	.84-.94	.033-.037	26.7	6.00	1.56	1.56		X

PARTS LIST

Item Number	Order Number	Description	Qty
1	63811-2375	Locator Ass'y **	1
2	11-11-0324	Spring (Main)	1
3	11-11-0320	Spring (Ratchet)	1

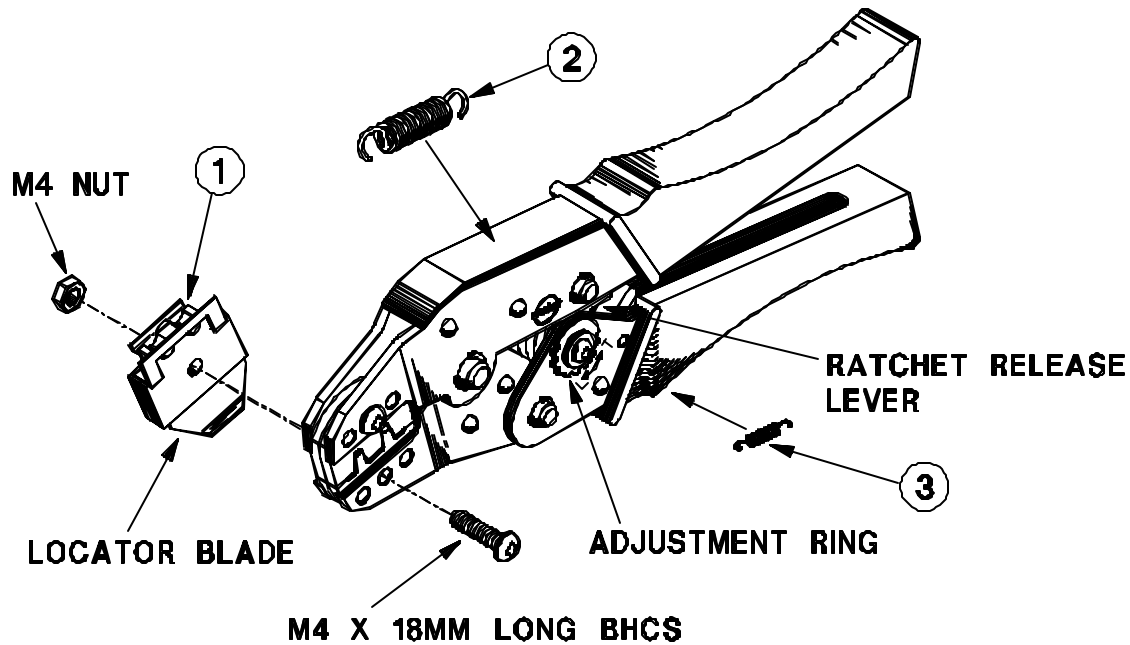

** Not all tools are equipped with a locator or locator blade.

Fig. 1

Notes:

1. This tool should only be used for the terminals and wire gauges specified on this sheet.
2. This tool is not adjustable for crimp height, however crimp force is adjustable (see instructions on page 4) Variations in tools, terminals, wire strandings and insulation types may effect crimp height.
3. This tool is intended for standard conductor sizes. It may not give a good insulation crimp support for all insulation sizes and types.
4. Molex does not repair handtools (see warranty on page 4). The replacment parts listed are the only parts available for repair. If the handles or crimp tooling is damaged or worn, a new tool must be purchased.
5. Pull force should be used as the final criteria for an acceptable crimp. Pull force is measured with no influence from the insulation crimp. The insulation should be stripped long (1/2 in.) so the insulation grips on the terminal do not grip the wire insulation or the conductor. Refer to Molex Quality Crimping Handbook 63800-0029 for additional information on crimping and crimp testing.
6. Molex does not certify crimp handtools.
7. Hand held crimping tools are intended for low volume, prototyping or repair requirements only.

Caution: Repetitive use of this tool should be avoided.

Crimping Instructions

1. Open the tool by squeezing the handles together, at the end of the closing stroke, the ratchet mechanism will release the handles and the tool will spring open.
2. Lift the locator blade and place the terminal into the correct die profile (A or B), release the locator blade. Not all tools are equipped with a locator or locator blade.
3. Partially close the tool until the terminal is held in place. (see Fig. 2)
4. Place a wire into the terminal and up against the locator blade (see Fig. 3). On tools without locators line the wire up with the conductor and insulation grips visually.
5. Close the tool until the ratchet releases. (see Fig. 4)
6. Lift the locator blade or wire stop and carefully remove the crimped terminal.

Fig. 2

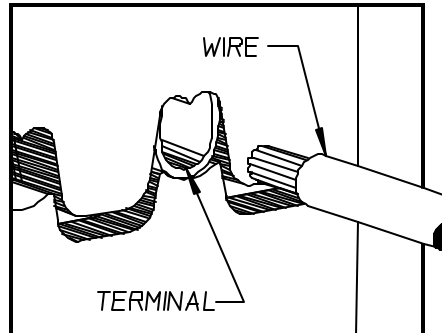

Fig. 3

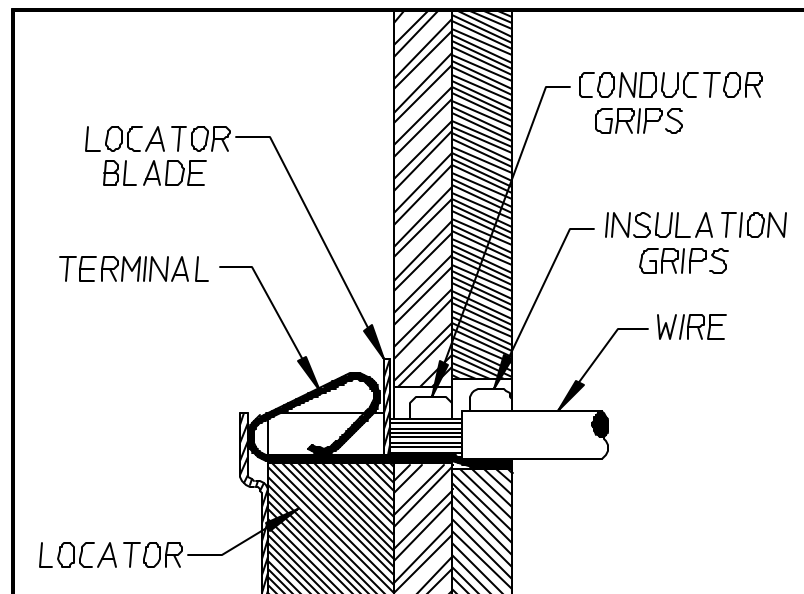
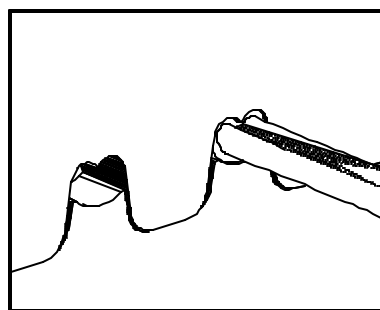

Fig. 4



Maintenance

It is recommended that each operator of the tool be made aware of, and responsible for, the following maintenance steps:

1. Remove dust, moisture and other contaminants with a clean brush, or soft, lint free cloth.
2. Do not use any abrasive materials that could damage the tool.
3. Make certain all pins, pivot points and bearing surfaces are protected with a thin coat of high quality machine oil. Do not oil excessively.
4. When tool is not in use, keep the handles closed to prevent objects from becoming lodged in the crimping dies, and store the tool in a clean, dry area.

Miscrimps or Jams (see Fig. 1)

Should this tool ever become stuck or jammed in a partially closed position, **Do Not** force the handles open or closed. The tool will open easily by lifting the ratchet release lever.

How To Adjust Tool Crimp Force (see Fig. 1)

It may be necessary over the life of the tool to adjust tool crimping force. Listed below are the steps required to adjust the crimping force of the handtool to obtain proper crimp conditions:

1. Remove the screw and washer. Located over the adjustment ring.
2. Lift the adjusting ring slightly, off of the locating pin.
3. Turn the adjusting ring in the desired direction (L= less force, T= more force) to increase or decrease crimp pressure.
4. Press the adjusting wheel flat against the tool and engage the locking pin.
5. Replace the washer and screw.
6. Check the crimp specifications after tool crimp force is adjusted.

Warranty

This tool is for electrical terminal crimping purposes only. This tool is made of the best quality materials. All vital components are long life tested. All tools are warranted to be free of manufacturing defects for a period of **30 days**. Should such a defect occur, we will exchange the tool free of charge. This exchange will not be applicable to altered, misused, or damaged tools. This tool is designed for hand use only. Any clamping, fixturing, or use of handle extensions voids this warranty.

**Molex Application Tooling Group
1150 E. Diehl Rd.
Naperville, Il. 60563
tel: 630-969-4550 fax: 630-505-0049**