

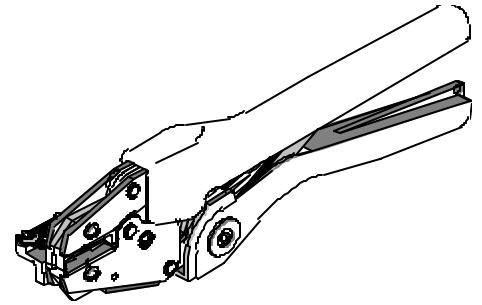

**Hand Crimp Tool
Operating Instruction Sheet
And Specifications
Part No. 64001-1000
Eng. No. RHT 5758-CC
(Replaces 19285-0038)**



FEATURES

- A full cycle ratcheting hand tool ensures complete crimps
- Long handles for comfortable crimping with reduced crimping force
- A precision user-friendly terminal locator wire stop holds terminals in the proper crimping position
- Single color-coded crimp pocket eliminates the possibility of using the wrong pocket

SCOPE

InsulKrimp™ Fully Insulated Quick Disconnect and, Perma-Seal™ Fully Insulated Quick Disconnect Conductor Crimp only 14–16 AWG.

Testing

Mechanical

The tensile test, or pull test, is a means of evaluating the mechanical properties of the crimped connections. The following charts show the UL specifications for various wire sizes. The tensile strength is shown in pounds and indicates the minimum acceptable force to break or separate the terminal from the conductor.

Wire Size (AWG)	*UL - 310
16	30
14	50

*UL – 310 – Quick Disconnects

The following is a partial list of the product part numbers and their specifications that this tool is designed to run. We will be adding to this list and an up to date copy is available on www.molex.com.

Wire Size: 14 – 16 AWG 2.00 – 1.30 mm ²					
Terminal No.	Terminal Eng No. (REF)	Wire Strip Length		Insul. Dia. Max.	
		In	mm	In	mm
19003-0040	BB-2206	0.25	6.35	0.16	4.064
19003-0044	BB-2206VB	0.25	6.35	0.16	4.064
19003-0047	BB-2206X	0.25	6.35	0.26	6.604
19003-0050	BB-2207	0.25	6.35	0.26	6.604
19003-0053	BB-2207X	0.25	6.35	0.26	6.604
19003-0056	BB-2208	0.25	6.35	0.16	4.064

Wire Size: 14 – 16 AWG 2.00 – 1.30 mm ²					
Terminal	Terminal	Wire Strip Length		Insul. Dia. Max.	
		In	mm	In	mm
19003-0059	BB-2208X	0.25	6.35	0.26	6.604
19003-0062	BB-2215	0.25	6.35	0.16	4.064
19003-0063	BB-2216	0.25	6.35	0.16	4.064
19023-0056	190230056		0	0.16	4.064
19164-0047	SBB-2141	0.20	5.16	0.24	6.096

OPERATION

Open the tool by first closing the jaws sufficiently for the ratchet mechanism to release.

Crimping Terminals

1. There are 2 tab locator blades supplied with the tool. One is for .187 and .250 tabs; the other is for .205 tabs and .110 tabs. Make sure the proper blade is installed on the top of the locator and the other is stored on the bottom of the locator.

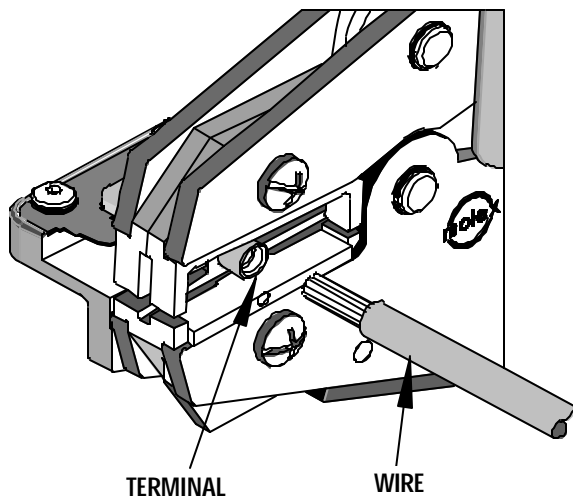

Figure 2

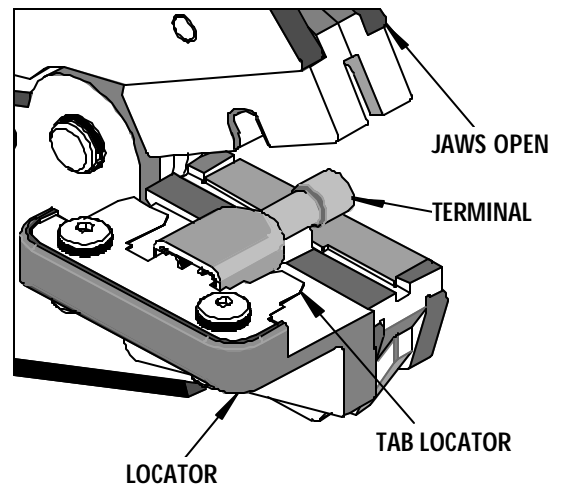

Figure 1

2. Push the terminal onto the tab locator all the way to the stop in the color-coded nest. The barrel of the terminal should be up (See Figure 1).
3. Partially close the tool to hold the terminal in place (See Figure 2).
4. Insert the properly stripped wire into the terminal barrel (See Figure 2 and 3). Cycle the tool.

Note: The tamper proof ratchet action will not release the tool until it has been fully closed.

5. Remove the crimp and inspect for proper crimp location. Molex offers a Crimp Inspection Handbook for closed barrel industrial product. See our website or contact your sales engineer.

Note: Whenever crimping without the locator, make sure the seam of the terminal is oriented up or down in the tool if using unbrazed product, as this will provide higher pull force values.

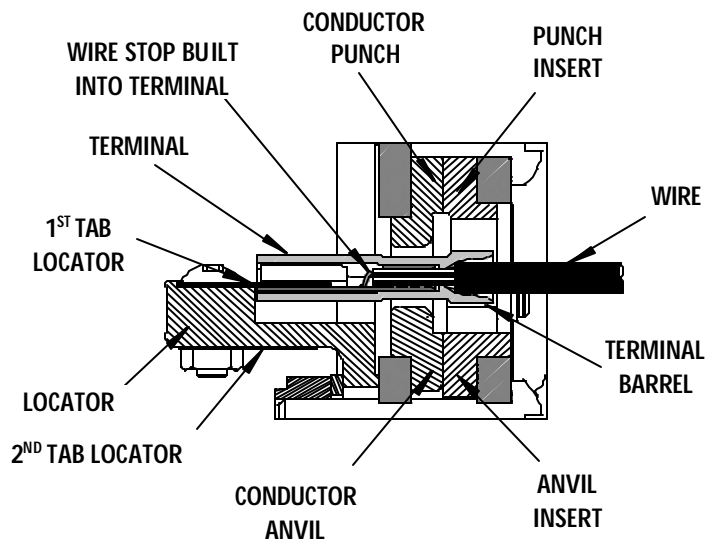

Figure 3

Maintenance

It is recommended that each operator of the tool be made aware of, and responsible for, the following maintenance steps:

1. Remove dust, moisture and other contaminants with a clean brush, or soft, lint-free cloth.
2. Do not use any abrasive materials that could damage the tool.
3. Make certain all pin, pivot points and bearing surfaces are protected with a thin coat of high quality machine oil. Do not oil excessively. The 64001-1000 (RHT-5758-CC) was engineered for durability, but like any fine piece of equipment it needs cleaning and lubrication for a maximum service life of trouble-free crimping. A light oil, such as 30 weight automotive oil used at the oil points shown in Figure 4, every 5,000 crimps or 3 months will significantly enhance the tool life and ensure a stable calibration.
4. When tool is not in use, keep the handles closed to prevent objects from becoming lodged in the crimping dies, and store the tool in a clean, dry area.

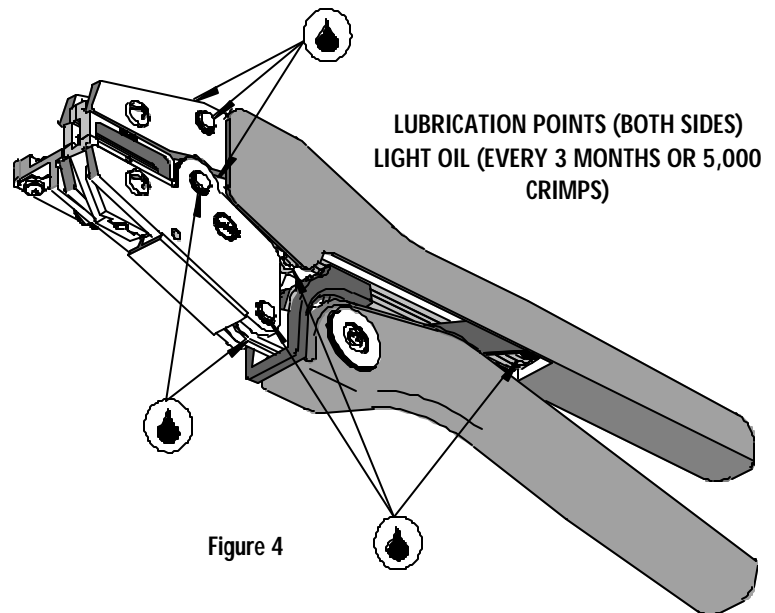

Figure 4

Miscrimps or Jams

Should this tool ever become stuck or jammed in a partially closed position, **Do Not** force the handles open or closed. The tool will open easily by pressing the ratchet release lever (See Figure 5).

How To Adjust Tool Preload (See Figure 5)

Over the life of the tool, it may be necessary to adjust tool handle preload force. Listed below are the steps required to adjust the crimping force of the hand tool to obtain proper crimp conditions:

1. Remove the screw and plastic cover washer. Note the setting wheel position.
2. Lift the setting wheel off the axle. Turn the eccentric axle with a screwdriver.
3. Turning the eccentric axle counter-clockwise will increase handle force.
4. Replace the setting wheel to the axle, aligning the nearest notch in the setting wheel to the dowel pin.
5. Replace the plastic cover washer and screw.
6. Check the crimp specifications after tool crimp force is adjusted.

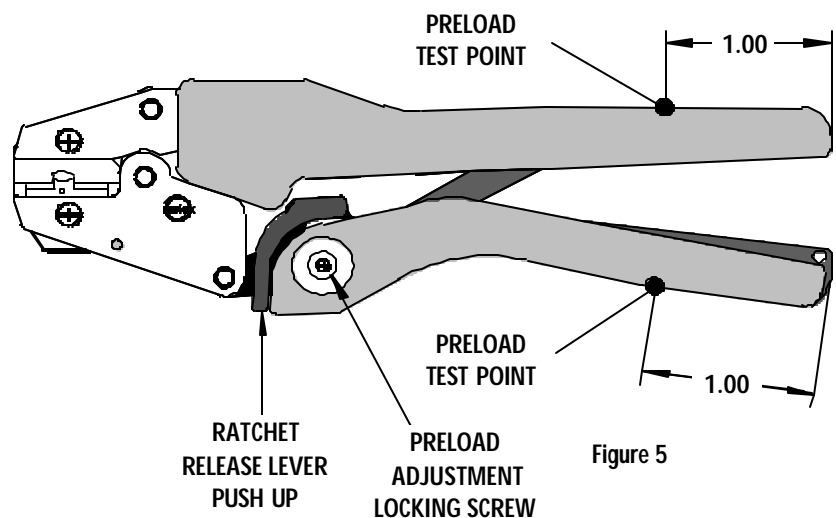
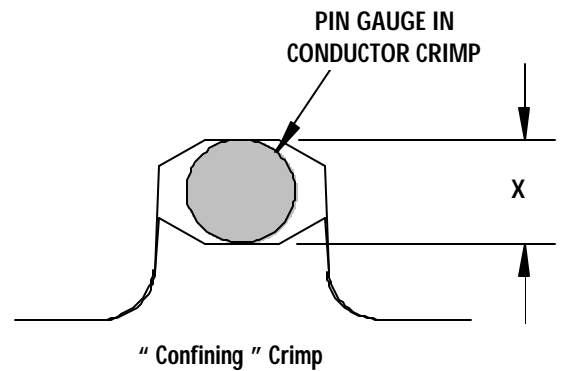

Figure 5

Tool Calibration

A Certificate of Calibration (see last page) was supplied with the tool. To recalibrate this tool, pin gauge measurements should be taken in each conductor nest and compared to this chart. The tool should be lubricated prior to recalibration to ensure consistent measurements. Handle preload is factory set to 25-45 LBS. See How to Adjust Tool Preload (See Figure 5) to recalibrate.



Nest Color Code	Wire Range		"X" Dimension Conductor Crimp			Crimp Inspection Marking
	AWG	mm ²	Mean	Go	No Go	
Blue	14 - 16	1.30 - 2.00	.094	.091	.098	0

Warranty

This tool is for electrical terminal crimping purposes only. This tool is made of the best quality materials. All vital components are long-life tested. All tools are warranted to be free of manufacturing defects for a period of 30 days. Should such a defect occur, we will repair or exchange the tool free of charge. This repair or exchange will not be applicable to altered, misused or damaged tools. This tool is designed for hand use only. Any clamping, fixturing, or use of handle extensions voids this warranty.

Hand held crimping tools are intended for low volume, prototyping or repair requirements only.

Caution: Repetitive use of this tool should be avoided.

PARTS LIST

Item	Order No	Description	Quantity
	64001-1000	Hand Crimp Tool	(Fig. 6)
1	64000-0076	Repair Kit (Springs, Pins and E-Rings)	1
2	63810-0000	Handle	1
3	64001-0275	Locator Assembly	1
4	64001-1070	Tooling Kit	1
Tooling Kit Only			
5	64001-1001	Conductor Punch	1
6	64001-1002	Conductor Anvil	1
7	64001-1012	Insert Punch	1
8	64001-1011	Insert Anvil	1
9	N/A	4 mm Dia. by 5.0 mm Lg. Roll Pins	2**

** The following purchased parts are available from an Industrial supply company such as MSC (1-800-645-7270).

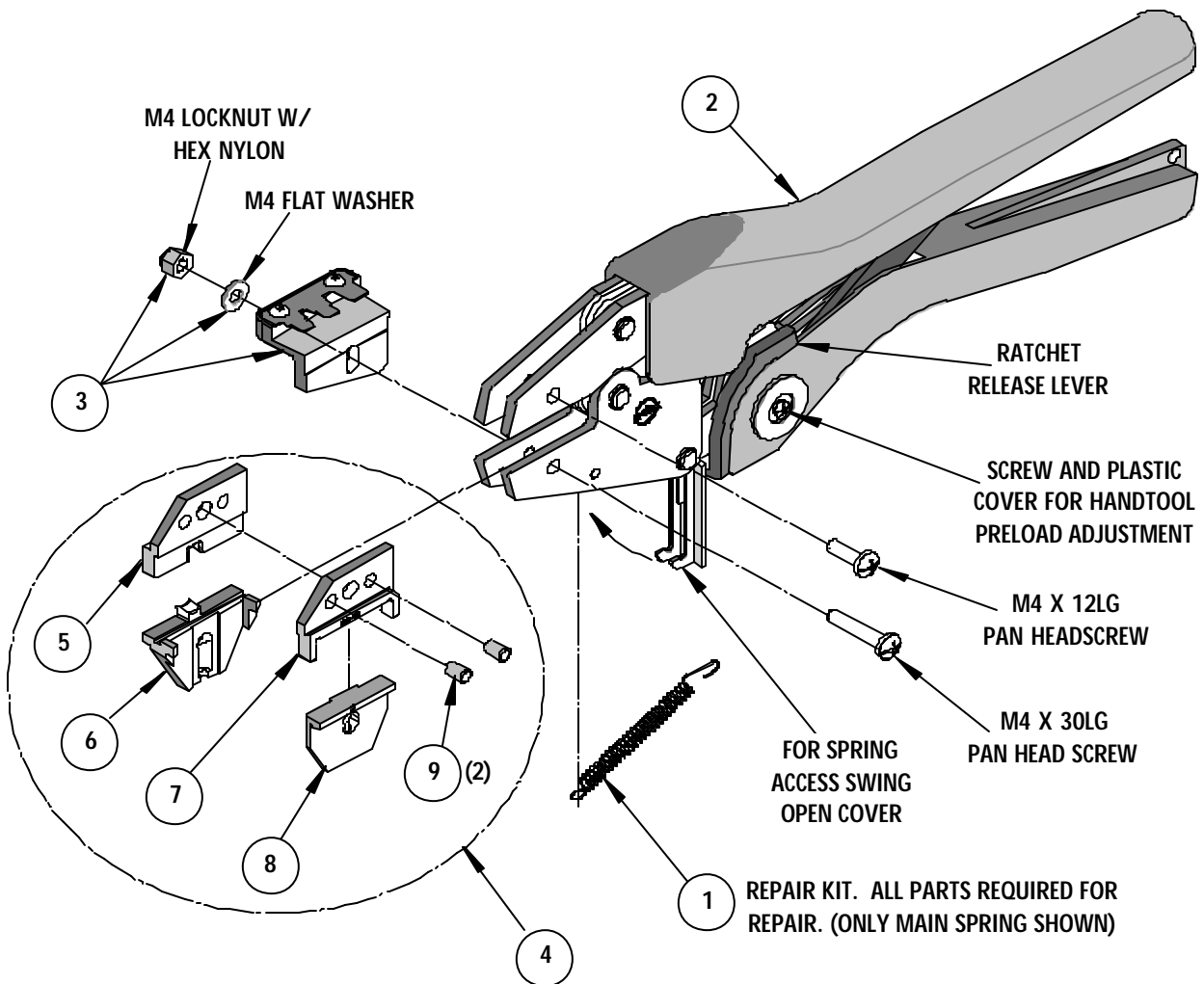
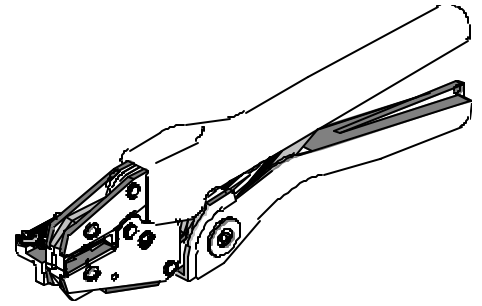

Figure 6



Certificate of Calibration

Tool Order Number _____

Tool Eng. Number _____

Tool Revision _____

Serial Number _____

Date of Manufacture _____

Handle Load Range at 1 inch from the Tips = _____

Actual = _____

Pin Gauge of Conductor Nest/Nests or Slug height if the nest is the "F" Crimp style.

Range Conductor Nest # 1 = _____ -- Actual = _____

Range Conductor Nest # 2 = _____ -- Actual = _____

Range Conductor Nest # 3 = _____ -- Actual = _____

Technician _____

Date of Calibration _____

Calibration should be done every 5,000 cycles or 3 months.
Tools should be lubricated during this operation.

Molex Application Tooling Group

1150 E. Diehl Road
Naperville, IL 60563
Tel: (630) 969-4550
Fax (630) 505-0049