

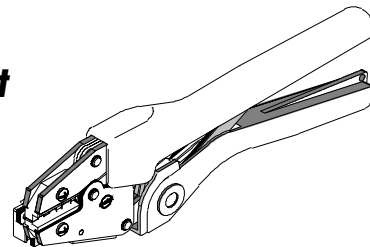

Hand Crimp Tool
Operating Instruction and Specifications Sheet
Part No. 64003-0100
Eng. No. RHT 1992
 (Replaces 19284-0014)



FEATURES

- **A full cycle ratcheting hand tool ensures complete crimps**
- **Long handles for comfortable crimping with reduced crimping force**
- **A precision user-friendly terminal locator / wire stop holds terminals in the proper crimping position for each of the three nests**
- **3-nested tool eliminates the need for additional tools**

SCOPE

Krimptite™ / VersaKrimp™ Terminals and Splices 10–22 AWG.

Testing

Mechanical

The tensile test, or pull test is, a means of evaluating the mechanical properties of the crimped connections. The following charts show the UL and Government specifications (MIL-T-7928) for various wire sizes. The tensile strength is shown in pounds and indicating the minimum acceptable force to break or separate the terminal from the conductor.

Wire Size (AWG)	*UL - 486 A	*UL - 486 C	**Military
22	8	8	15
20	13	10	19
18	20	10	38
16	30	15	50
14	50	25	70
12	70	35	110
10	80	40	150

***UL - 486 A - Terminals (Copper conductors only)**

***UL - 486 C - Butt Splices, Parallel Splices**

****Military – Military Approved Terminals only as listed**

The following is a partial list of the product part numbers and their specifications that this tool is designed to run. We will be adding to this list and an up to date copy is available on www.molex.com

Wire Size: 18 – 22 AWG 0.80 – 0.35 mm ²			
Terminal No.	Terminal Eng No. (REF)	Wire Strip Length	
		In	mm
19022-0004	AMCT-1	0.281	7.137
19033-0001	A-159	0.281	7.137
19033-0003	A-169	0.281	7.137
19041-0005	A-142-10	0.281	7.137
19044-0034	A-120-04	0.281	7.137

Wire Size: 18 – 22 AWG 0.80 – 0.35 mm ²			
Terminal No.	Terminal Eng No. (REF)	Wire Strip Length	
		In	mm
19044-0063	A-120-02	0.281	7.137
19044-0066	A-120-06	0.281	7.137
19044-0068	A-121-06	0.281	7.137
19044-0069	A-121-08	0.281	7.137
19044-0070	A-121-08R90	0.281	7.137

RHT-1992 Hand Crimp Tool

Wire Size: 18 – 22 AWG 0.80 – 0.35 mm ²			
Terminal No.	Terminal Eng No. (REF)	Wire Strip Length	
		In	mm
19044-0072	A-121-10	0.281	7.137
19044-0074	A-122-10	0.281	7.137
19044-0075	A-122-14	0.281	7.137
19044-0078	A-126-10	0.281	7.137
19044-0079	A-126-14	0.281	7.137
19044-0081	A-126-38	0.281	7.137
19044-0082	A-126-56	0.281	7.137
19044-0083	A-132-04	0.281	7.137
19044-0084	A-132-06	0.281	7.137
19044-0086	A-132-08	0.281	7.137
19044-0090	A-133-08	0.281	7.137
19044-0091	A-133-10	0.281	7.137
19044-0213	A-121-04	0.281	7.137
19056-0006	A-320-02	0.281	7.137
19056-0008	A-320-04	0.281	7.137
19056-0010	A-320-06	0.281	7.137
19056-0013	A-321-06	0.281	7.137
19056-0015	A-321-08	0.281	7.137
19056-0018	A-321-10	0.281	7.137
19056-0021	A-322-10	0.281	7.137
19056-0023	A-322-14	0.281	7.137
19056-0025	A-322-56	0.281	7.137
19056-0027	A-326-10	0.281	7.137
19056-0029	A-326-14	0.281	7.137
19056-0031	A-326-38	0.281	7.137
19056-0033	A-326-56	0.281	7.137
19056-0035	A-332-04	0.281	7.137
19056-0037	A-332-06	0.281	7.137
19056-0039	A-332-08	0.281	7.137
19056-0044	A-333-10	0.281	7.137
19069-0024	AA-1111-02	0.188	4.763
19069-0025	AA-1111-04	0.188	4.763
19069-0027	AA-120-02	0.188	4.763
19069-0029	AA-120-04	0.188	4.763
19069-0031	AA-120-06	0.188	4.763
19069-0033	AA-121-06	0.188	4.763
19069-0035	AA-121-08	0.188	4.763
19069-0037	AA-121-10	0.188	4.763
19069-0040	AA-122-10	0.188	4.763
19069-0042	AA-122-14	0.188	4.763
19069-0043	AA-122-14R90	0.188	4.763
19069-0045	AA-122-56	0.188	4.763
19069-0047	AA-126-10	0.188	4.763
19069-0048	AA-126-14	0.188	4.763
19069-0049	AA-126-38	0.188	4.763
19069-0051	AA-126-56	0.188	4.763
19069-0052	AA-132-04	0.188	4.763
19069-0054	AA-132-06	0.188	4.763
19069-0056	AA-132-08	0.188	4.763
19069-0061	AA-133-10	0.188	4.763
19079-0004	A-1006-MS	0.281	7.137
19086-0020	A-105-04	0.281	7.137
19086-0021	A-105-06	0.281	7.137
19086-0023	A-106-06	0.281	7.137
19086-0024	A-106-08	0.281	7.137
19086-0025	A-106-10	0.281	7.137
19086-0026	A-114-04	0.281	7.137
19086-0027	A-114-06	0.281	7.137
19086-0028	A-114-08	0.281	7.137

Wire Size: 18 – 22 AWG 0.80 – 0.35 mm ²			
Terminal No.	Terminal Eng No. (REF)	Wire Strip Length	
		In	mm
19086-0029	A-192-06	0.281	7.137
19086-0030	A-192-08	0.281	7.137
19086-0031	A-192-10	0.281	7.137
19086-0032	A-195-06	0.281	7.137
19086-0033	A-195-08	0.281	7.137
19086-0034	A-195-10	0.281	7.137
19086-0035	A-198-04	0.281	7.137
19086-0036	A-198-06	0.281	7.137
19086-0037	A-198-08	0.281	7.137
19086-0038	A-198-10	0.281	7.137
19086-0110	A-L80-08	0.296	7.518
19086-0112	A-L81-06	0.296	7.518
19086-0114	A-L83-05	0.296	7.518
19086-0116	A-L84-06	0.296	7.518
19086-0117	A-L85-04	0.296	7.518
19086-0118	A-L86-04	0.296	7.518
19086-0151	A-L82-08	0.296	7.518
19087-0029	AA-105-04	0.188	4.763
19087-0037	AA-1110-02	0.188	4.763
19087-0039	AA-1110-04	0.188	4.763
19087-0041	AA-114-04	0.188	4.763
19087-0043	AA-114-06	0.188	4.763
19087-0045	AA-114-08	0.188	4.763
19087-0054	AA-192-06	0.188	4.763
19087-0056	AA-192-08	0.188	4.763
19087-0058	AA-192-10	0.188	4.763
19087-0060	AA-195-06	0.188	4.763
19087-0062	AA-195-08	0.188	4.763
19087-0064	AA-195-10	0.188	4.763
19087-0066	AA-198-04	0.188	4.763
19087-0068	AA-198-06	0.188	4.763
19087-0070	AA-198-08	0.188	4.763
19087-0072	AA-198-10	0.188	4.763
19088-0001	A-305-04	0.281	7.137
19088-0002	A-305-06	0.281	7.137
19088-0004	A-306-06	0.281	7.137
19088-0005	A-306-08	0.281	7.137
19088-0006	A-306-10	0.281	7.137
19088-0007	A-314-04	0.281	7.137
19088-0008	A-314-06	0.281	7.137
19088-0009	A-314-08	0.281	7.137
19088-0010	A-392-06	0.281	7.137
19088-0011	A-392-08	0.281	7.137
19088-0012	A-392-10	0.281	7.137
19088-0013	A-395-06	0.281	7.137
19088-0014	A-395-08	0.281	7.137
19088-0015	A-395-10	0.281	7.137
19088-0016	A-398-04	0.281	7.137
19088-0017	A-398-06	0.281	7.137
19088-0018	A-398-08	0.281	7.137
19088-0019	A-398-10	0.281	7.137
19089-0031	AA-105-06	0.188	4.763
19093-0001	AA-305-04	0.188	4.763
19093-0003	AA-305-06	0.188	4.763
19093-0009	AA-3110-02	0.188	4.763
19093-0011	AA-3110-04	0.188	4.763
19093-0013	AA-314-04	0.188	4.763
19093-0015	AA-314-06	0.188	4.763
19093-0017	AA-314-08	0.188	4.763

RHT-1992 Hand Crimp Tool

Wire Size: 18 – 22 AWG 0.80 – 0.35 mm ²			
Terminal No.	Terminal Eng No. (REF)	Wire Strip Length	
		In	mm
19093-0019	AA-392-06	0.188	4.763
19093-0021	AA-392-08	0.188	4.763
19093-0023	AA-392-10	0.188	4.763
19093-0025	AA-395-06	0.188	4.763
19093-0027	AA-395-08	0.188	4.763
19093-0029	AA-395-10	0.188	4.763
19093-0031	AA-398-04	0.188	4.763
19093-0033	AA-398-06	0.188	4.763
19093-0035	AA-398-08	0.188	4.763
19093-0037	AA-398-10	0.188	4.763
19098-0011	AA-1190-06	0.188	4.763
19098-0013	AA-1191-08	0.188	4.763
19098-0015	AA-1192-10	0.188	4.763
19098-0017	AA-1704-05	0.188	4.763
19098-0018	AA-1704-06	0.188	4.763
19098-0021	AA-1705-08	0.188	4.763
19098-0022	AA-1706-10	0.188	4.763
19098-0023	AA-1714-08	0.188	4.763
19098-0024	AA-1715-10	0.188	4.763
19098-0097	AA-1704-04	0.188	4.763
19117-0015	A-115-04	0.281	7.137
19117-0016	A-115-06	0.281	7.137
19117-0018	A-115-08	0.281	7.137
19117-0020	A-115-10	0.281	7.137
19117-0023	A-190-06	0.281	7.137
19117-0024	A-190-08	0.281	7.137
19117-0025	A-190-10	0.281	7.137
19117-0026	A-193-06	0.281	7.137
19117-0027	A-193-08	0.281	7.137
19117-0028	A-193-10	0.281	7.137
19117-0029	A-196-04	0.281	7.137
19117-0030	A-196-06	0.281	7.137
19117-0031	A-196-08	0.281	7.137
19118-0018	AA-1108-02	0.188	4.763
19118-0019	AA-1108-04	0.188	4.763
19118-0020	AA-115-04	0.188	4.763
19118-0021	AA-115-06	0.188	4.763
19118-0023	AA-115-08	0.188	4.763
19118-0025	AA-115-10	0.188	4.763
19118-0026	AA-1461-04	0.188	4.763
19118-0027	AA-1461-06	0.188	4.763
19118-0028	AA-1461-08	0.188	4.763
19118-0029	AA-1461-10	0.188	4.763
19118-0030	AA-190-06	0.188	4.763
19118-0031	AA-190-08	0.188	4.763
19118-0032	AA-190-10	0.188	4.763
19118-0033	AA-193-06	0.188	4.763
19118-0034	AA-193-08	0.188	4.763
19118-0035	AA-193-10	0.188	4.763
19118-0037	AA-196-04	0.188	4.763
19118-0038	AA-196-06	0.188	4.763
19118-0039	AA-196-08	0.188	4.763
19123-0003	A-315-04	0.281	7.137
19123-0004	A-315-06	0.281	7.137
19123-0005	A-315-08	0.281	7.137
19123-0006	A-3461-04	0.281	7.137
19123-0007	A-3461-06	0.281	7.137
19123-0008	A-3461-08	0.281	7.137
19123-0009	A-3461-10	0.281	7.137

Wire Size: 18 – 22 AWG 0.80 – 0.35 mm ²			
Terminal No.	Terminal Eng No. (REF)	Wire Strip Length	
		In	mm
19123-0010	A-390-06	0.281	7.137
19123-0011	A-390-08	0.281	7.137
19123-0012	A-390-10	0.281	7.137
19123-0013	A-393-06	0.281	7.137
19123-0014	A-393-08	0.281	7.137
19123-0015	A-393-10	0.281	7.137
19123-0016	A-396-04	0.281	7.137
19123-0017	A-396-06	0.281	7.137
19123-0018	A-396-08	0.281	7.137
19124-0001	AA-3108-02	0.188	4.763
19124-0003	AA-3108-04	0.188	4.763
19124-0005	AA-315-04	0.188	4.763
19124-0007	AA-315-06	0.188	4.763
19124-0009	AA-315-08	0.188	4.763
19124-0011	AA-3461-04	0.188	4.763
19124-0012	AA-3461-06	0.188	4.763
19124-0013	AA-3461-08	0.188	4.763
19124-0014	AA-3461-10	0.188	4.763
19124-0015	AA-390-06	0.188	4.763
19124-0017	AA-390-08	0.188	4.763
19124-0019	AA-390-10	0.188	4.763
19124-0021	AA-393-06	0.188	4.763
19124-0023	AA-393-08	0.188	4.763
19124-0025	AA-393-10	0.188	4.763
19124-0027	AA-396-04	0.188	4.763
19124-0029	AA-396-06	0.188	4.763
19124-0031	AA-396-08	0.188	4.763
19124-0074	AA-315-10	0.188	4.763
19128-0004	A-1118-06	0.281	7.137
19128-0006	A-1118-08	0.281	7.137
19128-0008	A-1461-04	0.281	7.137
19128-0010	A-1461-06	0.281	7.137
19128-0012	A-1461-08	0.281	7.137
19128-0013	A-1461-10	0.281	7.137
19128-0035	A-191-06	0.281	7.137
19128-0036	A-191-08	0.281	7.137
19128-0037	A-191-10	0.281	7.137
19128-0038	A-194-06	0.281	7.137
19128-0039	A-194-08	0.281	7.137
19128-0040	A-194-10	0.281	7.137
19128-0041	A-197-04	0.281	7.137
19128-0042	A-197-06	0.281	7.137
19128-0043	A-197-08	0.281	7.137
19129-0023	AA-197-08	0.188	4.763
19129-0025	AA-197-06	0.188	4.763
19129-0027	AA-197-04	0.188	4.763
19129-0029	AA-191-10	0.188	4.763
19129-0031	AA-191-08	0.188	4.763
19129-0033	AA-191-06	0.188	4.763
19129-0035	AA-194-10	0.188	4.763
19129-0036	AA-194-08	0.188	4.763
19129-0037	AA-194-06	0.188	4.763
19129-0039	AA-138-06	0.188	4.763
19129-0041	AA-138-04	0.188	4.763
19129-0043	AA-134-10	0.188	4.763
19129-0045	AA-134-08	0.188	4.763
19129-0047	AA-134-06	0.188	4.763
19129-0048	AA-134-04	0.188	4.763
19129-0049	AA-1118-08	0.188	4.763

RHT-1992 Hand Crimp Tool

Wire Size: 18 – 22 AWG 0.80 – 0.35 mm ²			
Terminal No.	Terminal Eng No. (REF)	Wire Strip Length	
		In	mm
19129-0051	AA-1118-06	0.188	4.763
19129-0053	AA-1109-04	0.188	4.763
19129-0055	AA-1109-02	0.188	4.763
19134-0002	A-3118-06	0.281	7.137
19134-0003	A-3118-08	0.281	7.137
19134-0004	A-334-04	0.281	7.137
19134-0005	A-334-06	0.281	7.137
19134-0006	A-334-08	0.281	7.137
19134-0007	A-334-10	0.281	7.137
19134-0008	A-335-06	0.281	7.137
19134-0009	A-335-08	0.281	7.137
19134-0010	A-335-10	0.281	7.137
19135-0001	AA-3109-02	0.188	4.763
19135-0002	AA-3109-04	0.188	4.763
19140-0030	A-134-04	0.281	7.137
19140-0031	A-134-06	0.281	7.137
19140-0033	A-134-08	0.281	7.137
19140-0034	A-134-10	0.281	7.137
19140-0035	A-135-06	0.281	7.137
19140-0036	A-135-08	0.281	7.137
19140-0037	A-135-10	0.281	7.137
19140-0038	A-138-04	0.281	7.137
19140-0040	A-138-06	0.281	7.137
19141-0020	AA-135-06	0.188	4.763
19141-0022	AA-135-08	0.188	4.763
19141-0024	AA-135-10	0.188	4.763
19146-0004	A-338-04	0.281	7.137
19146-0005	A-338-06	0.281	7.137
19146-0007	A-391-06	0.281	7.137
19146-0008	A-391-08	0.281	7.137
19146-0009	A-391-10	0.281	7.137
19146-0010	A-394-06	0.281	7.137
19146-0011	A-394-08	0.281	7.137
19146-0012	A-394-10	0.281	7.137
19146-0013	A-397-04	0.281	7.137
19146-0014	A-397-06	0.281	7.137
19146-0015	A-397-08	0.281	7.137
19147-0002	AA-3118-06	0.188	4.763
19147-0003	AA-3118-08	0.188	4.763
19147-0004	AA-334-04	0.188	4.763
19147-0006	AA-334-06	0.188	4.763
19147-0008	AA-334-08	0.188	4.763
19147-0010	AA-334-10	0.188	4.763
19147-0011	AA-335-06	0.188	4.763
19147-0013	AA-335-08	0.188	4.763
19147-0015	AA-335-10	0.188	4.763
19147-0017	AA-338-04	0.188	4.763
19147-0019	AA-338-06	0.188	4.763
19147-0022	AA-391-06	0.188	4.763
19147-0024	AA-391-08	0.188	4.763
19147-0026	AA-391-10	0.188	4.763
19147-0028	AA-394-06	0.188	4.763
19147-0030	AA-394-08	0.188	4.763
19147-0032	AA-394-10	0.188	4.763
19147-0034	AA-397-04	0.188	4.763
19147-0036	AA-397-06	0.188	4.763
19147-0038	AA-397-08	0.188	4.763
19170-0001	A-110-06	0.281	7.137
19170-0003	A-110-08	0.281	7.137

Wire Size: 18 – 22 AWG 0.80 – 0.35 mm ²			
Terminal No.	Terminal Eng No. (REF)	Wire Strip Length	
		In	mm
19170-0005	A-110-10	0.281	7.137
19172-0001	A-310-06	0.281	7.137
19172-0003	A-310-08	0.281	7.137
19172-0005	A-310-10	0.281	7.137
19178-0002	AA-110-06	0.188	4.763
19178-0004	AA-110-08	0.188	4.763
19178-0006	AA-110-10	0.188	4.763
19180-0002	AA-310-06	0.188	4.763
19180-0003	AA-310-08	0.188	4.763
19180-0005	AA-310-10	0.188	4.763
19189-0002	A-145	0.234	5.944
19189-0003	A-145-B	0.234	5.944
19189-0005	A-145	0.281	7.137
19193-0007	AA-320-04	0.188	4.763
19193-0009	AA-320-06	0.188	4.763
19193-0012	AA-321-06	0.188	4.763
19193-0014	AA-321-08	0.188	4.763
19193-0016	AA-321-10	0.188	4.763
19193-0019	AA-322-10	0.188	4.763
19193-0021	AA-322-14	0.188	4.763
19193-0023	AA-322-56	0.188	4.763
19193-0025	AA-326-10	0.188	4.763
19193-0026	AA-326-14	0.188	4.763
19193-0028	AA-326-38	0.188	4.763
19193-0030	AA-326-56	0.188	4.763
19193-0032	AA-332-04	0.188	4.763
19193-0034	AA-332-06	0.188	4.763
19193-0036	AA-332-08	0.188	4.763
19193-0041	AA-333-10	0.188	4.763
19193-0044	AA-T-320-06	0.188	4.763
19193-0049	AA-T-332-06	0.188	4.763
19193-0394	AA-3111-02	0.188	4.763
19193-0396	AA-3111-04	0.188	4.763
19193-0398	AA-320-02	0.188	4.763
19193-0448	AA-T-322-14	0.188	4.763
19193-0613	AA-T-333-10	0.188	4.763
19203-0008	A-S-132-04	0.281	7.137
19203-0015	A-S-133-10	0.281	7.137
19203-0144	A-S-122-14	0.281	7.137
19203-0145	A-S-132-06	0.281	7.137
19203-0146	A-S-132-08	0.281	7.137
19203-0164	A-S-145	0.250	6.350
19203-0165	A-T-302	0.250	6.350
19203-0166	A-T-345	0.281	7.137
19203-0204	AA-U-132-06	0.188	4.763
19203-0205	AA-U-132-08	0.188	4.763
19203-0206	AA-U-133-10	0.188	4.763
19203-0221	AA-T-320-04	0.188	4.763
19203-0222	AA-T-322-56	0.188	4.763
19203-0226	A-S-120-06	0.281	7.137
19203-0229	A-S-122-56	0.281	7.137
19203-0301	A-S-126-38	0.281	7.137
19204-0001	A-1XC	0.281	7.137
19204-0002	A-1YC	0.281	7.137
19204-0005	A-3YC	0.281	7.137
19204-0006	A-3XC	0.281	7.137
19207-0001	AS-302	0.281	7.137
19211-0003	WP-1614	0.188	4.763
19215-0009	AS-345	0.281	7.137

Wire Size: 14 - 16 AWG 2.00 - 1.30 mm ²			
Terminal No.	Terminal Eng No. (REF)	Wire Strip Length	
		In	mm
19033-0005	B-179	0.188	4.763
19033-0007	B-189	0.188	4.763
19044-0028	B-137-04	0.281	7.137
19044-0030	B-137-06	0.281	7.137
19044-0031	B-137-08	0.281	7.137
19044-0032	B-137-10	0.281	7.137
19044-0033	B-139-04	0.281	7.137
19044-0035	B-139-06	0.281	7.137
19044-0037	B-139-08	0.281	7.137
19044-0039	B-139-10	0.281	7.137
19044-0137	B-101-12HD	0.281	7.137
19044-0139	B-101-14HD	0.281	7.137
19044-0140	B-101-38HD	0.281	7.137
19044-0141	B-101-56HD	0.281	7.137
19044-0142	B-101-76HD	0.281	7.137
19044-0143	B-118-10	0.281	7.137
19044-0143	BB-118-10	0.188	4.763
19044-0144	B-118-14	0.281	7.137
19044-0144	BB-118-14	0.188	4.763
19044-0146	B-118-38	0.281	7.137
19044-0146	BB-118-38	0.188	4.763
19044-0148	B-118-56	0.281	7.137
19044-0148	BB-118-56	0.188	4.763
19044-0149	B-123-02	0.281	7.137
19044-0150	B-123-04	0.281	7.137
19044-0152	B-123-06	0.281	7.137
19044-0154	B-123-08	0.281	7.137
19044-0156	B-125-10	0.281	7.137
19044-0158	B-125-14	0.281	7.137
19044-0160	B-125-56	0.281	7.137
19056-0053	B-318-10	0.281	7.137
19056-0055	B-318-14	0.281	7.137
19056-0057	B-318-38	0.281	7.137
19056-0059	B-318-56	0.281	7.137
19056-0061	B-323-02	0.281	7.137
19056-0063	B-323-04	0.281	7.137
19056-0065	B-323-06	0.281	7.137
19056-0068	B-323-08	0.281	7.137
19056-0070	B-325-10	0.281	7.137
19056-0072	B-325-14	0.281	7.137
19056-0075	B-325-56	0.281	7.137
19056-0102	B-337-04	0.281	7.137
19056-0104	B-337-06	0.281	7.137
19056-0106	B-337-08	0.281	7.137
19056-0109	B-337-10	0.281	7.137
19056-0112	B-339-04	0.281	7.137
19056-0114	B-339-06	0.281	7.137
19056-0116	B-339-08	0.281	7.137
19056-0118	B-339-10	0.281	7.137
19056-0141	B-323-06R90	0.281	7.137
19069-0098	BB-123-02	0.188	4.763
19069-0099	BB-123-04	0.188	4.763
19069-0101	BB-123-06	0.188	4.763
19069-0103	BB-123-08	0.188	4.763
19069-0105	BB-125-10	0.188	4.763
19069-0107	BB-125-14	0.188	4.763
19069-0109	BB-125-56	0.188	4.763
19069-0111	BB-137-04	0.188	4.763

Wire Size: 14 - 16 AWG 2.00 - 1.30 mm ²			
Terminal No.	Terminal Eng No. (REF)	Wire Strip Length	
		In	mm
19069-0112	BB-137-06	0.188	4.763
19069-0114	BB-137-08	0.188	4.763
19069-0116	BB-137-10	0.188	4.763
19069-0119	BB-139-04	0.188	4.763
19069-0120	BB-139-06	0.188	4.763
19069-0121	BB-139-08	0.188	4.763
19069-0123	BB-139-10	0.188	4.763
19079-0007	B-1006-MS	0.281	7.137
19086-0065	B-108-04	0.281	7.137
19086-0066	B-108-06	0.281	7.137
19086-0068	B-108-08	0.281	7.137
19086-0070	B-109-06	0.281	7.137
19086-0071	B-109-08	0.281	7.137
19086-0072	B-109-10	0.281	7.137
19086-0073	B-113-04	0.281	7.137
19086-0073	BB-113-04	0.188	4.763
19086-0074	B-113-06	0.281	7.137
19086-0074	BB-113-06	0.188	4.763
19086-0075	B-113-08	0.281	7.137
19086-0075	BB-113-08	0.188	4.763
19086-0076	B-182-06	0.281	7.137
19086-0077	B-182-08	0.281	7.137
19086-0078	B-182-10	0.281	7.137
19086-0079	B-185-06	0.281	7.137
19086-0080	B-186-08	0.281	7.137
19086-0081	B-185-10	0.281	7.137
19086-0082	B-188-04	0.281	7.137
19086-0083	B-188-06	0.281	7.137
19086-0084	B-188-08	0.281	7.137
19086-0144	B-L80-08	0.296	7.518
19086-0145	B-L81-06	0.296	7.518
19086-0146	B-L82-08	0.296	7.518
19086-0147	B-L83-05	0.296	7.518
19086-0148	B-L84-06	0.296	7.518
19086-0149	B-L85-04	0.296	7.518
19086-0150	B-L86-04	0.296	7.518
19087-0104	BB-182-06	0.188	4.763
19087-0106	BB-182-08	0.188	4.763
19087-0108	BB-182-10	0.188	4.763
19087-0113	BB-185-06	0.188	4.763
19087-0115	BB-185-08	0.188	4.763
19087-0117	BB-185-10	0.188	4.763
19087-0122	BB-188-04	0.188	4.763
19087-0124	BB-188-06	0.188	4.763
19087-0126	BB-188-08	0.188	4.763
19087-0128	BB-188-10	0.188	4.763
19088-0020	B-308-04	0.281	7.137
19088-0021	B-308-06	0.281	7.137
19088-0024	B-309-06	0.281	7.137
19088-0025	B-309-08	0.281	7.137
19088-0026	B-309-10	0.281	7.137
19088-0027	B-313-04	0.281	7.137
19088-0028	B-313-06	0.281	7.137
19088-0029	B-313-08	0.281	7.137
19088-0034	B-382-06	0.281	7.137
19088-0035	B-382-08	0.281	7.137
19088-0036	B-382-10	0.281	7.137
19088-0037	B-385-06	0.281	7.137
19088-0038	B-385-08	0.281	7.137

RHT-1992 Hand Crimp Tool

Wire Size: 14 – 16 AWG 2.00 – 1.30 mm ²			
Terminal No.	Terminal Eng No. (REF)	Wire Strip Length	
		In	mm
19088-0039	B-385-10	0.281	7.137
19088-0040	B-388-04	0.281	7.137
19088-0041	B-388-06	0.281	7.137
19088-0042	B-388-08	0.281	7.137
19088-0043	B-388-10	0.281	7.137
19093-0039	BB-313-04	0.188	4.763
19093-0041	BB-313-06	0.188	4.763
19093-0043	BB-313-08	0.188	4.763
19093-0045	BB-382-06	0.188	4.763
19093-0047	BB-382-08	0.188	4.763
19093-0049	BB-382-10	0.188	4.763
19093-0051	BB-385-06	0.188	4.763
19093-0053	BB-385-08	0.188	4.763
19093-0055	BB-385-10	0.188	4.763
19093-0057	BB-388-04	0.188	4.763
19093-0059	BB-388-06	0.188	4.763
19093-0061	BB-388-08	0.188	4.763
19093-0063	BB-388-10	0.188	4.763
19098-0034	BB-1193-06	0.188	4.763
19098-0036	BB-1194-08	0.188	4.763
19098-0038	BB-1195-10	0.188	4.763
19098-0041	BB-1707-05	0.188	4.763
19098-0043	BB-1707-06	0.188	4.763
19098-0047	BB-1716-08	0.188	4.763
19098-0049	BB-1717-10	0.188	4.763
19117-0048	B-116-04	0.281	7.137
19117-0048	BB-116-04	0.188	4.763
19117-0052	B-116-10	0.281	7.137
19117-0052	BB-116-10	0.188	4.763
19117-0058	B-1491-06	0.281	7.137
19117-0059	B-1491-08	0.281	7.137
19117-0060	B-1491-10	0.281	7.137
19117-0061	B-180-06	0.281	7.137
19117-0062	B-180-08	0.281	7.137
19117-0063	B-180-10	0.281	7.137
19117-0064	B-183-06	0.281	7.137
19117-0065	B-183-08	0.281	7.137
19117-0066	B-183-10	0.281	7.137
19117-0068	B-186-04	0.281	7.137
19117-0069	B-186-06	0.281	7.137
19117-0070	B-186-08	0.281	7.137
19117-0083	B-116-06	0.281	7.137
19117-0083	BB-116-06	0.188	4.763
19117-0084	B-116-08	0.281	7.137
19117-0084	BB-116-08	0.188	4.763
19118-0060	BB-1491-06	0.188	4.763
19118-0061	BB-1491-08	0.188	4.763
19118-0062	BB-1491-10	0.188	4.763
19118-0063	BB-180-06	0.188	4.763
19118-0064	BB-180-08	0.188	4.763
19118-0065	BB-180-10	0.188	4.763
19118-0066	BB-183-06	0.188	4.763
19118-0067	BB-183-08	0.188	4.763
19118-0068	BB-183-10	0.188	4.763
19118-0070	BB-186-04	0.188	4.763
19118-0071	BB-186-06	0.188	4.763
19118-0072	BB-186-08	0.188	4.763
19123-0019	B-316-04	0.281	7.137
19123-0020	B-316-06	0.281	7.137

Wire Size: 14 – 16 AWG 2.00 – 1.30 mm ²			
Terminal No.	Terminal Eng No. (REF)	Wire Strip Length	
		In	mm
19123-0021	B-316-08	0.281	7.137
19123-0022	B-316-10	0.281	7.137
19123-0027	B-3491-06	0.281	7.137
19123-0028	B-3491-08	0.281	7.137
19123-0029	B-3491-10	0.281	7.137
19123-0030	B-380-06	0.281	7.137
19123-0031	B-380-08	0.281	7.137
19123-0032	B-380-10	0.281	7.137
19123-0033	B-383-06	0.281	7.137
19123-0034	B-383-08	0.281	7.137
19123-0035	B-383-10	0.281	7.137
19123-0036	B-386-04	0.281	7.137
19123-0037	B-386-06	0.281	7.137
19123-0038	B-386-08	0.281	7.137
19124-0033	BB-316-04	0.188	4.763
19124-0035	BB-316-06	0.188	4.763
19124-0037	BB-316-08	0.188	4.763
19124-0040	BB-3491-06	0.188	4.763
19124-0041	BB-3491-08	0.188	4.763
19124-0042	BB-3491-10	0.188	4.763
19124-0043	BB-380-06	0.188	4.763
19124-0045	BB-380-08	0.188	4.763
19124-0047	BB-380-10	0.188	4.763
19124-0049	BB-383-06	0.188	4.763
19124-0051	BB-383-08	0.188	4.763
19124-0053	BB-383-10	0.188	4.763
19124-0055	BB-386-04	0.188	4.763
19124-0057	BB-386-06	0.188	4.763
19124-0059	BB-386-08	0.188	4.763
19124-0075	BB-316-10	0.188	4.763
19128-0014	B-1471-04	0.281	7.137
19128-0016	B-1471-06	0.281	7.137
19128-0021	B-1781-06	0.281	7.137
19128-0023	B-1781-08	0.281	7.137
19128-0025	B-1781-10	0.281	7.137
19128-0026	B-181-06	0.281	7.137
19128-0027	B-181-08	0.281	7.137
19128-0028	B-181-10	0.281	7.137
19128-0029	B-184-06	0.281	7.137
19128-0030	B-184-08	0.281	7.137
19128-0031	B-184-10	0.281	7.137
19128-0032	B-187-04	0.281	7.137
19128-0033	B-187-06	0.281	7.137
19128-0034	B-187-08	0.281	7.137
19129-0002	BB-181-10	0.188	4.763
19129-0003	BB-181-08	0.188	4.763
19129-0004	BB-181-06	0.188	4.763
19129-0012	BB-187-08	0.188	4.763
19129-0013	BB-187-06	0.188	4.763
19129-0014	BB-187-04	0.188	4.763
19129-0015	BB-184-10	0.188	4.763
19129-0016	BB-184-08	0.188	4.763
19129-0017	BB-184-06	0.188	4.763
19129-0020	BB-1781-10	0.188	4.763
19129-0022	BB-1781-08	0.188	4.763
19129-0024	BB-1781-06	0.188	4.763
19129-0026	BB-1781-04	0.188	4.763
19129-0030	BB-1471-06	0.188	4.763
19129-0032	BB-1471-04	0.188	4.763

RHT-1992 Hand Crimp Tool

Wire Size: 14 – 16 AWG 2.00 – 1.30 mm ²			
Terminal No.	Terminal Eng No. (REF)	Wire Strip Length	
		In	mm
19140-0085	B-107-04	0.281	7.137
19140-0085	BB-107-04	0.188	4.763
19140-0086	B-107-06	0.281	7.137
19140-0086	BB-107-06	0.188	4.763
19140-0087	B-124-04	0.281	7.137
19140-0088	B-124-06	0.281	7.137
19140-0089	B-124-08	0.281	7.137
19140-0090	B-127-06	0.281	7.137
19140-0091	B-127-08	0.281	7.137
19140-0093	B-127-10	0.281	7.137
19141-0054	BB-124-04	0.188	4.763
19141-0056	BB-124-06	0.188	4.763
19141-0058	BB-124-08	0.188	4.763
19141-0061	BB-127-06	0.188	4.763
19141-0063	BB-127-08	0.188	4.763
19141-0065	BB-127-10	0.188	4.763
19146-0016	B-307-04	0.281	7.137
19146-0017	B-307-06	0.281	7.137
19146-0018	B-324-04	0.281	7.137
19146-0019	B-324-06	0.281	7.137
19146-0021	B-324-08	0.281	7.137
19146-0024	B-327-06	0.281	7.137
19146-0025	B-327-08	0.281	7.137
19146-0029	B-3471-04	0.281	7.137
19146-0030	B-3471-06	0.281	7.137
19146-0034	B-3781-04	0.281	7.137
19146-0035	B-3781-06	0.281	7.137
19146-0036	B-3781-08	0.281	7.137
19146-0037	B-3781-10	0.281	7.137
19146-0038	B-381-06	0.281	7.137
19146-0039	B-381-08	0.281	7.137
19146-0040	B-381-10	0.281	7.137
19146-0041	B-384-06	0.281	7.137
19146-0042	B-384-08	0.281	7.137
19146-0043	B-384-10	0.281	7.137
19146-0044	B-387-04	0.281	7.137
19146-0045	B-387-06	0.281	7.137
19146-0046	B-387-08	0.281	7.137
19146-0096	B-327-10	0.281	7.137
19147-0040	BB-307-04	0.188	4.763
19147-0042	BB-307-06	0.188	4.763
19147-0044	BB-324-04	0.188	4.763
19147-0046	BB-324-06	0.188	4.763
19147-0048	BB-324-08	0.188	4.763
19147-0050	BB-327-06	0.188	4.763
19147-0052	BB-327-08	0.188	4.763
19147-0054	BB-327-10	0.188	4.763
19147-0056	BB-3471-04	0.188	4.763
19147-0057	BB-3471-06	0.188	4.763
19147-0058	BB-3781-04	0.188	4.763
19147-0059	BB-3781-06	0.188	4.763
19147-0061	BB-3781-08	0.188	4.763
19147-0062	BB-3781-10	0.188	4.763
19147-0064	BB-381-06	0.188	4.763
19147-0066	BB-381-08	0.188	4.763
19147-0068	BB-381-10	0.188	4.763
19147-0070	BB-384-06	0.188	4.763
19147-0072	BB-384-08	0.188	4.763
19147-0074	BB-384-10	0.188	4.763

Wire Size: 14 – 16 AWG 2.00 – 1.30 mm ²			
Terminal No.	Terminal Eng No. (REF)	Wire Strip Length	
		In	mm
19147-0076	BB-387-04	0.188	4.763
19147-0078	BB-387-06	0.188	4.763
19147-0080	BB-387-08	0.188	4.763
19170-0007	B-119-06	0.281	7.137
19170-0007	BB-119-06	0.188	4.763
19170-0009	B-119-08	0.281	7.137
19170-0009	BB-119-08	0.188	4.763
19170-0011	B-119-10	0.281	7.137
19170-0011	BB-119-10	0.188	4.763
19172-0007	B-319-06	0.281	7.137
19172-0009	B-319-08	0.281	7.137
19172-0011	B-319-10	0.281	7.137
19180-0007	BB-319-06	0.188	4.763
19180-0009	BB-319-08	0.188	4.763
19180-0011	BB-319-10	0.188	4.763
19189-0008	B-131	0.234	5.944
19189-0009	B-131-B	0.234	5.944
19189-0012	B-131	0.281	7.137
19193-0053	BB-318-10	0.188	4.763
19193-0055	BB-318-14	0.188	4.763
19193-0057	BB-318-38	0.188	4.763
19193-0060	BB-318-56	0.188	4.763
19193-0062	BB-323-02	0.188	4.763
19193-0064	BB-323-04	0.188	4.763
19193-0066	BB-323-06	0.188	4.763
19193-0068	BB-323-08	0.188	4.763
19193-0070	BB-325-10	0.188	4.763
19193-0072	BB-325-14	0.188	4.763
19193-0074	BB-325-56	0.188	4.763
19193-0076	BB-337-04	0.188	4.763
19193-0078	BB-337-06	0.188	4.763
19193-0080	BB-337-08	0.188	4.763
19193-0082	BB-337-10	0.188	4.763
19193-0085	BB-339-04	0.188	4.763
19193-0087	BB-339-06	0.188	4.763
19193-0089	BB-339-08	0.188	4.763
19193-0091	BB-339-10	0.188	4.763
19202-0023	B-N-131	0.234	5.944
19203-0042	B-S-123-06	0.281	7.137
19203-0044	B-S-125-14	0.281	7.137
19203-0047	B-S-137-06	0.296	7.540
19203-0049	B-S-137-08	0.281	7.137
19203-0051	B-S-137-10	0.281	7.137
19203-0061	BB-T-337-08	0.188	4.763
19203-0063	BB-T-337-10	0.188	4.763
19203-0070	BB-T-437-06	0.250	6.350
19203-0072	BB-T-437-08	0.250	6.350
19203-0074	BB-T-437-10	0.250	6.350
19203-0077	BB-U-123-06	0.188	4.763
19203-0079	BB-U-125-14	0.188	4.763
19203-0083	BB-U-137-08	0.188	4.763
19203-0085	BB-U-137-10	0.188	4.763
19203-0147	BB-T-323-06	0.188	4.763
19203-0148	BB-T-325-14	0.188	4.763
19203-0149	BB-T-337-06	0.188	4.763
19203-0150	BB-U-137-06	0.188	4.763
19203-0170	B-S-131	0.296	7.540
19203-0171	B-T-331	0.296	7.540
19203-0172	B-T-304	0.281	7.137

Wire Size: 14 – 16 AWG 2.00 – 1.30 mm ²			
Terminal No.	Terminal Eng No. (REF)	Wire Strip Length	
		In	mm
19203-0202	B-S-127-10	0.281	7.137
19203-0223	BB-T-318-38	0.188	4.763
19203-0233	B-S-125-56	0.281	7.137
19203-0274	BB-U-125-56	0.188	4.763
19203-0302	B-S-118-38	0.281	7.137
19204-0011	B-1XC	0.281	7.137
19204-0012	B-1YC	0.281	7.137
19204-0015	B-3XC	0.281	7.137
19204-0016	B-3YC	0.281	7.137
19205-0001	BS-304	0.281	7.137
19208-0001	B-104	0.281	7.137
19211-0005	WP-1614	0.188	4.763
19215-0013	BA-331	0.281	7.137
19215-0018	BS-331	0.281	7.137
19022-0018	MCT-1	0.281	7.137
19022-0021	MCT-1-N	0.281	7.137
19022-0027	MMCT-1	0.187	4.760

HEAVY DUTY			
Wire Size: 14 – 16 AWG 2.00 – 1.30 mm ²			
Also suitable for 12 AWG 3.00 mm ² Use 10-12 Pocket (YELLOW)			
Terminal No.	Terminal Eng No. (REF)	Wire Strip Length	
		In	mm
19044-0137	B-101-12HD	0.281	7.137
19044-0139	B-101-14HD	0.281	7.137
19044-0140	B-101-38HD	0.281	7.137
19044-0141	B-101-56HD	0.281	7.137
19044-0142	B-101-76HD	0.281	7.137
19044-0161	B-128-06HD	0.281	7.137
19044-0162	B-128-08HD	0.281	7.137
19044-0163	B-128-10HD	0.281	7.137
19044-0166	B-130-10HD	0.281	7.137
19044-0167	B-130-14HD	0.281	7.137
19044-0168	B-130-56HD	0.281	7.137
19044-0172	B-136-04HD	0.281	7.137
19044-0173	B-136-06HD	0.281	7.137
19044-0174	B-136-08HD	0.281	7.137
19044-0180	B-140-10HD	0.281	7.137
19044-0182	B-140-14HD	0.281	7.137
19044-0184	B-140-38HD	0.281	7.137
19044-0186	B-140-56HD	0.281	7.137
19056-0049	B-301-56HD	0.281	7.137
19056-0079	B-328-06HD	0.281	7.137
19056-0081	B-328-08HD	0.281	7.137
19056-0083	B-328-10HD	0.281	7.137
19056-0085	B-330-10HD	0.281	7.137
19056-0087	B-330-14HD	0.281	7.137
19056-0089	B-330-56HD	0.281	7.137
19056-0095	B-336-04HD	0.281	7.137
19056-0121	B-340-10HD	0.281	7.137
19056-0125	B-340-38HD	0.281	7.137
19117-0054	B-117-06HD	0.281	7.137
19117-0055	B-117-08HD	0.281	7.137
19117-0056	B-117-10HD	0.281	7.137
19123-0023	B-317-06HD	0.281	7.137
19123-0025	B-317-10HD	0.281	7.137
19140-0095	B-141-06HD	0.281	7.137
19140-0097	B-141-08HD	0.281	7.137
19140-0098	B-141-10HD	0.281	7.137

HEAVY DUTY			
Wire Size: 14 – 16 AWG 2.00 – 1.30 mm ²			
Also suitable for 12 AWG 3.00 mm ² Use 10-12 Pocket (YELLOW)			
Terminal No.	Terminal Eng No. (REF)	Wire Strip Length	
		In	mm
19140-0099	B-168-10HD	0.281	7.137
19140-0100	B-168-14HD	0.281	7.137
19140-0101	B-168-56HD	0.281	7.137
19146-0027	B-341-08HD	0.281	7.137
19146-0031	B-368-10HD	0.281	7.137
19146-0033	B-368-56HD	0.281	7.137

Wire Size: 10 – 12 AWG 5.00 – 3.00 mm ²			
Terminal No.	Terminal Eng No. (REF)	Wire Strip Length	
		In	mm
19000-0303	C-128-08R90	0.281	7.137
19000-0304	C-128-10R90	0.281	7.137
19069-0180	C-030-14	0.281	7.137
19069-0192	C-101-12	0.281	7.137
19069-0195	C-101-14	0.281	7.137
19069-0196	C-101-38	0.281	7.137
19069-0197	C-101-56	0.281	7.137
19069-0198	C-101-76	0.281	7.137
19069-0200	C-128-04	0.281	7.137
19069-0202	C-128-06	0.281	7.137
19069-0205	C-128-08	0.281	7.137
19069-0209	C-128-10	0.281	7.137
19069-0217	C-130-10	0.281	7.137
19069-0219	C-130-14	0.281	7.137
19069-0222	C-130-38	0.281	7.137
19069-0223	C-130-56	0.281	7.137
19069-0229	C-136-04	0.281	7.137
19069-0230	C-136-06	0.281	7.137
19069-0233	C-136-08	0.281	7.137
19069-0234	C-136-08R90	0.281	7.137
19069-0236	C-140-10	0.281	7.137
19069-0238	C-140-14	0.281	7.137
19069-0241	C-140-38	0.281	7.137
19069-0244	C-140-56	0.281	7.137
19079-0011	C-1006-MS	0.281	7.137
19087-0145	C-1103-08	0.281	7.137
19087-0147	C-1106-06	0.281	7.137
19087-0149	C-112-06	0.281	7.137
19087-0151	C-112-08	0.281	7.137
19087-0153	C-112-10	0.281	7.137
19093-0067	C-3106-06	0.281	7.137
19093-0069	C-312-06	0.281	7.137
19093-0071	C-312-08	0.281	7.137
19093-0073	C-312-10	0.281	7.137
19098-0061	C-1196-06	0.281	7.137
19098-0063	C-1197-08	0.281	7.137
19098-0065	C-1198-10	0.281	7.137
19098-0067	C-1199-14	0.281	7.137
19098-0068	C-1710-05	0.281	7.137
19098-0069	C-1710-06	0.281	7.137
19098-0073	C-1718-08	0.281	7.137
19098-0074	C-1719-10	0.281	7.137
19118-0078	C-1101-08	0.281	7.137
19118-0079	C-1104-06	0.281	7.137
19118-0080	C-1104-08	0.281	7.137
19118-0082	C-1104-10	0.281	7.137
19118-0084	C-117-06	0.281	7.137

RHT-1992 Hand Crimp Tool

Wire Size: 10 – 12 AWG 5.00 – 3.00 mm ²			
Terminal No.	Terminal Eng No. (REF)	Wire Strip Length	
		In	mm
19118-0086	C-117-08	0.281	7.137
19118-0088	C-117-10	0.281	7.137
19124-0061	C-3101-08	0.281	7.137
19124-0063	C-3104-06	0.281	7.137
19124-0065	C-3104-08	0.281	7.137
19124-0066	C-3104-10	0.281	7.137
19124-0067	C-317-06	0.281	7.137
19124-0069	C-317-08	0.281	7.137
19124-0071	C-317-10	0.281	7.137
19129-0001	C-1481-10	0.281	7.137
19129-0005	C-1105-10	0.281	7.137
19129-0007	C-1105-08	0.281	7.137
19129-0008	C-1105-06	0.281	7.137
19129-0010	C-1102-08	0.281	7.137
19141-0081	C-141-06	0.281	7.137
19141-0083	C-141-08	0.281	7.137
19141-0085	C-141-10	0.281	7.137
19141-0087	C-168-10	0.281	7.137
19141-0088	C-168-14	0.281	7.137
19141-0090	C-168-56	0.281	7.137
19147-0083	C-3102-08	0.281	7.137
19147-0086	C-3105-06	0.281	7.137
19147-0088	C-3105-08	0.281	7.137
19147-0090	C-3105-10	0.281	7.137
19147-0092	C-341-06	0.281	7.137
19147-0096	C-341-10	0.281	7.137
19147-0099	C-3481-10	0.281	7.137
19147-0100	C-368-10	0.281	7.137
19147-0101	C-368-14	0.281	7.137
19147-0103	C-368-56	0.281	7.137
19147-0105	C-341-08	0.281	7.137
19178-0014	C-111-06	0.281	7.137
19178-0016	C-111-08	0.281	7.137
19178-0018	C-111-10	0.281	7.137
19178-0020	C-199-14	0.281	7.137
19178-0021	C-199-56	0.281	7.137
19180-0013	C-311-06	0.281	7.137
19180-0015	C-311-08	0.281	7.137
19180-0017	C-311-10	0.281	7.137
19180-0019	C-399-14	0.281	7.137
19189-0015	C-146	0.234	5.950
19189-0016	C-146-B	0.234	5.950
19189-0018	C-L146	0.359	9.119
19193-0096	C-301-14	0.281	7.137
19193-0097	C-301-38	0.281	7.137
19193-0098	C-301-56	0.281	7.137
19193-0099	C-301-76	0.281	7.137
19193-0101	C-328-04	0.281	7.137
19193-0103	C-328-06	0.281	7.137
19193-0106	C-328-08	0.281	7.137
19193-0112	C-328-209	0.281	7.137
19193-0114	C-330-10	0.281	7.137
19193-0116	C-330-14	0.281	7.137
19193-0126	C-336-04	0.281	7.137
19193-0130	C-336-08	0.281	7.137

Wire Size: 10 – 12 AWG 5.00 – 3.00 mm ²			
Terminal No.	Terminal Eng No. (REF)	Wire Strip Length	
		In	mm
19193-0132	C-340-10	0.281	7.137
19193-0134	C-340-14	0.281	7.137
19193-0141	C-340-56	0.281	7.137
19193-0532	C-328-10R90	0.281	7.137
19203-0091	C-5-128-06	0.281	7.137
19203-0093	C-5-128-10	0.281	7.137
19203-0099	C-340-38	0.281	7.144
19203-0113	C-U-128-10	0.281	7.137
19203-0151	C-5-128-08	0.281	7.137
19203-0152	C-5-130-14	0.281	7.137
19203-0153	C-5-130-56	0.281	7.137
19203-0154	C-5-140-38	0.281	7.137
19203-0155	C-T-328-06	0.281	7.137
19203-0156	C-330-56	0.281	7.144
19203-0157	C-T-330-56	0.281	7.137
19203-0158	C-T-328-10	0.281	7.144
19203-0158	C-T-340-38	0.281	7.137
19203-0159	C-U-128-06	0.281	7.137
19203-0160	C-U-128-08	0.281	7.137
19203-0161	C-U-130-14	0.281	7.137
19203-0162	C-U-130-56	0.281	7.137
19203-0163	C-U-140-38	0.281	7.137
19203-0167	C-5-146	0.234	5.950
19203-0169	C-T-303	0.281	7.140
19203-0182	C-T-328-08	0.281	7.144
19203-0182	C-T-330-14	0.281	7.137
19203-0183	C-T-346	0.359	9.119
19203-0224	C-T-430-56	0.375	9.520
19203-0228	C-5-128-04	0.281	7.137
19203-0235	C-5-141-10	0.281	7.137
19203-0236	C-T-428-08	0.375	9.520
19203-0236	C-T-428-08	0.375	9.520
19203-0237	C-U-428-10	0.375	9.520
19203-0276	C-T-430-14	0.375	9.520
19204-0023	C-1XC	0.281	7.137
19204-0024	C-1YC	0.281	7.137
19204-0027	C-3XC	0.281	7.137
19204-0028	C-3YC	0.281	7.137
19205-0003	CS-303	0.281	7.137
19208-0002	C-103	0.281	7.137
19211-0001	WP-1210	0.281	7.144
19215-0023	CB-346	0.359	9.119
19215-0028	CS-346	0.359	9.120

MILITARY Wire Size: 10 – 12 AWG 5.00 – 3.00 mm ²			
Terminal No.	Terminal Eng No. (REF)	Wire Strip Length	
		In	mm
19193-0094	C-301-12	0.281	7.137
19193-0109	C-328-10	0.281	7.137
19193-0120	C-330-56	0.281	7.137
19193-0128	C-336-06	0.281	7.137
19193-0137	C-340-38	0.281	7.137

OPERATION

Open the tool by first closing the jaws sufficiently for the ratchet mechanism to release.

Crimping Terminals

1. Lift the locator and insert the terminal in the proper nest with the barrel up and against the locator bar. Release the locator blade to hold the terminal in position (See Figure 1). Locator may be raised or lowered so terminal sits flat and straight in tool. The locator must be removed to run splices.

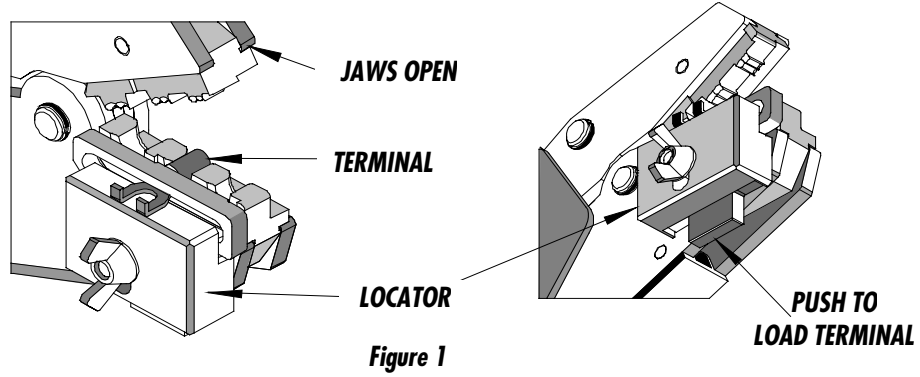

2. **Partially close the tool to hold the terminal in place (See Figure 2).**
3. **Insert the properly stripped wire into the terminal barrel (See Figure 2 and 3). The wires end should stop against the locator bar. Cycle the tool.**

Note: The tamper proof ratchet action will not release the tool until it has been fully closed.

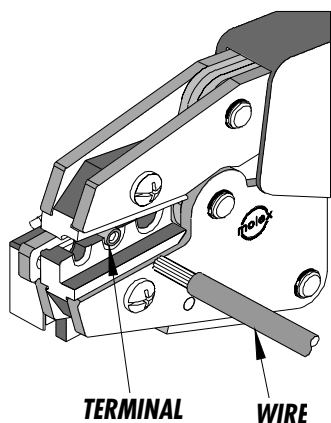

Figure 2

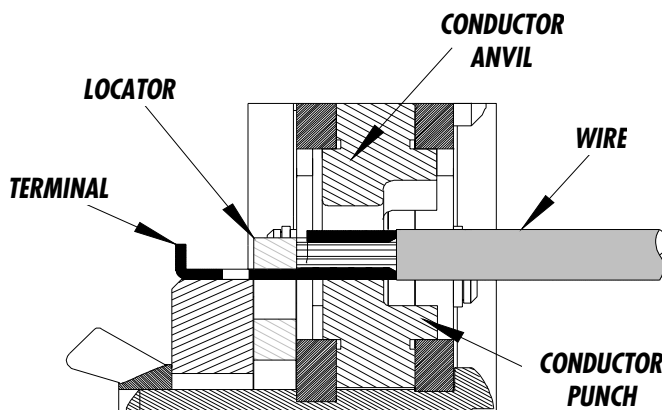

Figure 3

4. **Remove the crimp and inspect for proper crimp location. Locator is adjustable up and down to keep terminals straight after crimping (See Figure 1). Molex offers a Crimp Inspection Handbook for closed barrel industrial product. See our website or contact your sales engineer.**
5. **When crimping butt splices, the locator must be removed. Insert the wire into the butt splice. Position the splice and the wire in proper coded nest with conductor crimp on the conductor barrel of the splice. The splice should be approximately centered inside the tooling nests (See Figure 4). Cycle the tool.**

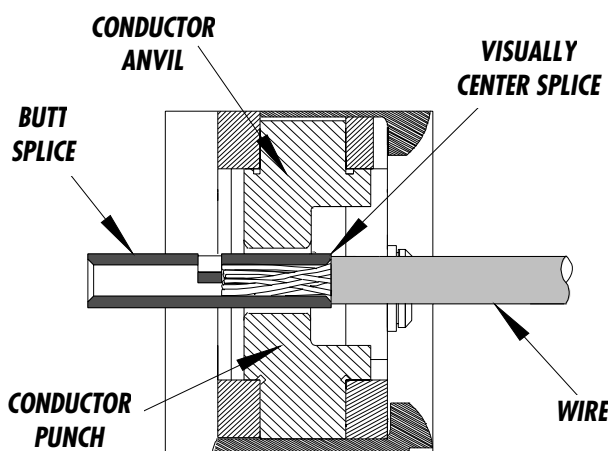

Figure 4

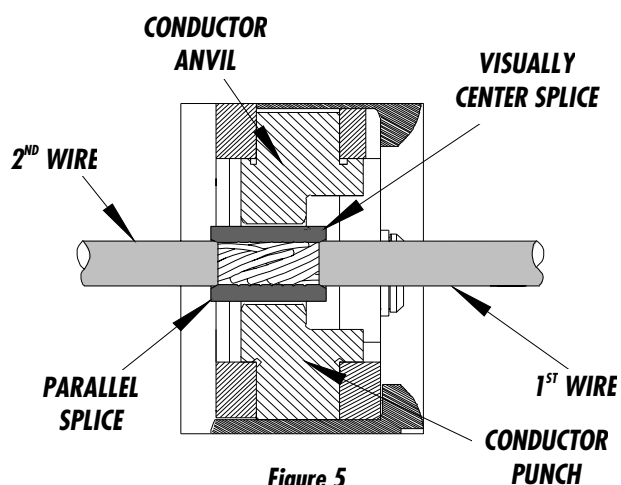

Figure 5

6. **When crimping parallel splices, the locator must be removed. Insert the 1st wire into one end of splice then insert the 2nd wire into the opposite end of the parallel splice. This procedure will crimp both wires at the same time. Make sure the wires are fully seated into the parallel splice. Position the splice and the wires in proper**

coded nest with conductor crimp on the conductor barrel of the splice The splice should be approximately centered inside the tooling nests (See Figure 5). Cycle the tool.

Maintenance

It is recommended that each operator of the tool be made aware of, and responsible for, the following maintenance steps:

1. Remove dust, moisture and other contaminants with a clean brush, or soft, lint-free cloth.
2. Do not use any abrasive materials that could damage the tool.
3. Make certain all pins; pivot points and bearing surfaces are protected with a thin coat of high quality machine oil. Do not oil excessively. The 64003-0100 (RHT-1992) was engineered for durability, but like any fine piece of equipment, it needs cleaning and lubrication for a maximum service life of trouble-free crimping. A light oil, such as 30 weight automotive oil used at the oil points shown in Figure 6, every 5,000 crimps or 3 months will significantly enhance the tool life and ensure a stable calibration.
4. When tool is not in use, keep the handles closed to prevent objects from becoming lodged in the crimping dies, and store the tool in a clean, dry area.

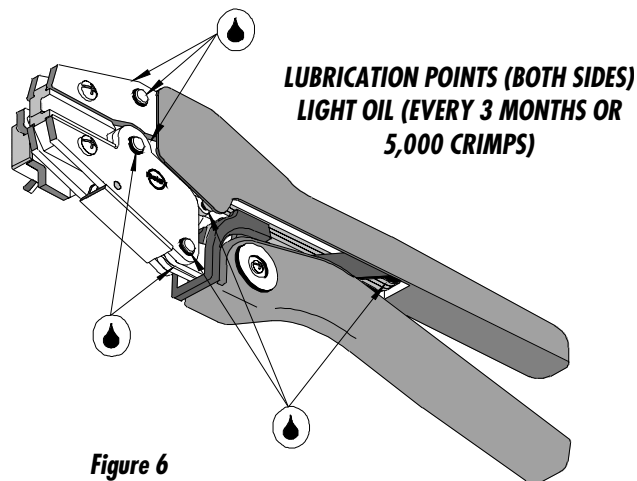

Figure 6

Note: Whenever crimping without the locator, make sure the seam of the terminal is oriented up or down in the tool if using unbrazed product, as this will provide higher pull force values.

Miscrimps or Jams

Should this tool ever become stuck or jammed in a partially closed position, **Do Not force the handles open or closed.** The tool will open easily by pressing the ratchet release lever (See Figure 7).

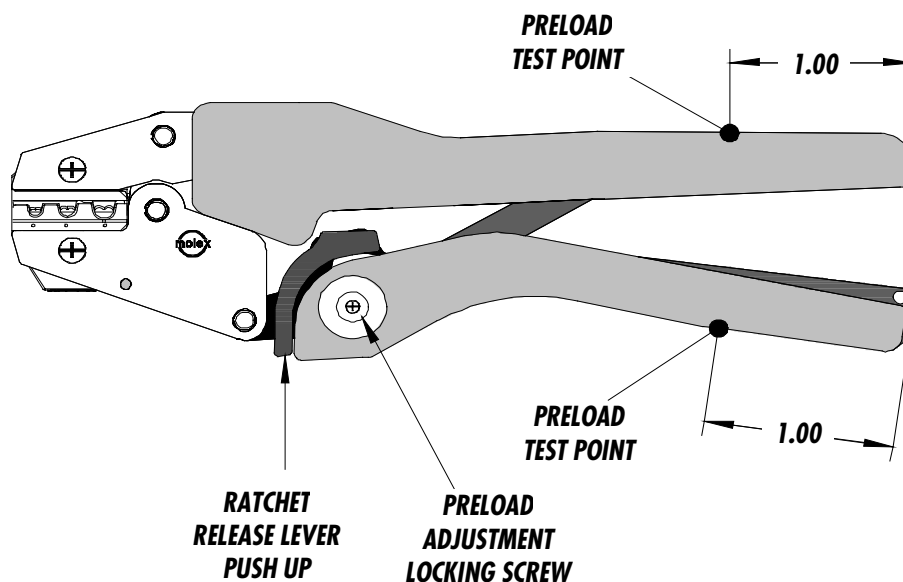

Figure 7

How to Adjust Tool Preload (See Figure 7)

Over the life of the tool, it may be necessary to adjust tool handle preload force. Listed below are the steps required to adjust the crimping force of the hand tool to obtain proper crimp conditions:

1. Remove the screw and plastic cover washer. Note the setting wheel position.
2. Lift the setting wheel off the axle. Turn the eccentric axle with a screwdriver.
3. Turning the eccentric axle counter-clockwise (CCW) will increase handle force.
4. Replace the setting wheel to the axle, aligning the nearest notch in the setting wheel to the dowel pin.
5. Replace the plastic cover washer and screw.
6. Check the crimp specifications after tool handle preload force is adjusted.

Tool Calibration

A Certificate of Calibration (See Last Page) was supplied with the tool. To recalibrate this Tool, a soft metal slug or solder should be crimped in the conductor nest and the "X" Dimension measured in each conductor nest and compared to this chart. The tool should be lubricated before recalibration to ensure consistent measurements. Handle preload is factory set to 25-45 LBS. See How to Adjust Tool Preload (See Figure 7) to recalibrate.

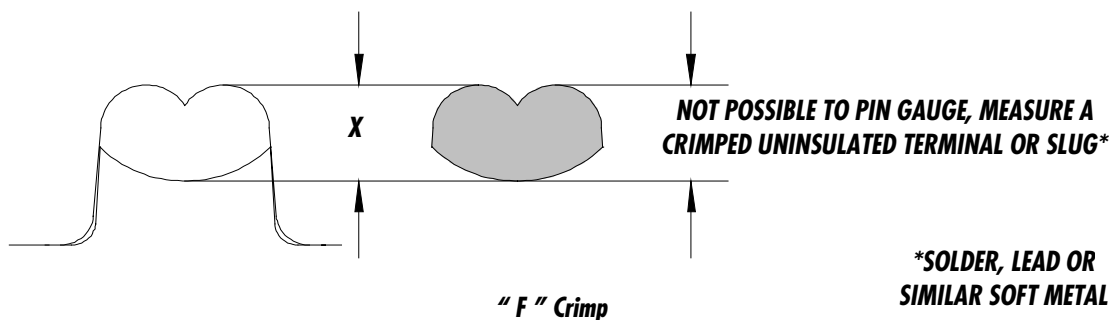

Nest Color Code	Wire Range		"X" Dimension Conductor Crimp		
	AWG	mm ²	Mean	Go	No Go
Red	18 - 22	0.35 - 0.80	.073	.068	.078
Blue	14 - 16	1.30 - 2.00	.095	.089	.101
Yellow	10 - 12	3.30 - 5.00	.127	.121	.133

Warranty

This tool is for electrical terminal crimping purposes only. This tool is made of the best quality materials. All vital components are long-life tested. All tools are warranted free of manufacturing defects for a period of 30 days. Should such a defect occur, we will repair or exchange the tool free of charge. This repair or exchange will not be applicable to altered, misused or damaged tools. This tool is designed for hand use only. Any clamping, fixturing, or use of handle extensions voids this warranty.

Hand held crimping tools are intended for low volume, prototyping, or repair requirements only.

Caution: Repetitive use of this tool should be avoided.

PARTS LIST

Item	Order No	Description	Quantity
	64003-0100	Hand Crimp Tool	(Fig. 8)
1	64000-0076	Repair Kit (Springs, Pins and E-Handle)	1
2	63810-0000	Handle	1
3	64007-0375	Locator Assembly	1
4	64003-0170	Tooling Kit	1
Tooling Kit Only			
5	64003-0102	Conductor Anvil	1
6	64003-0101	Conductor Punch	1

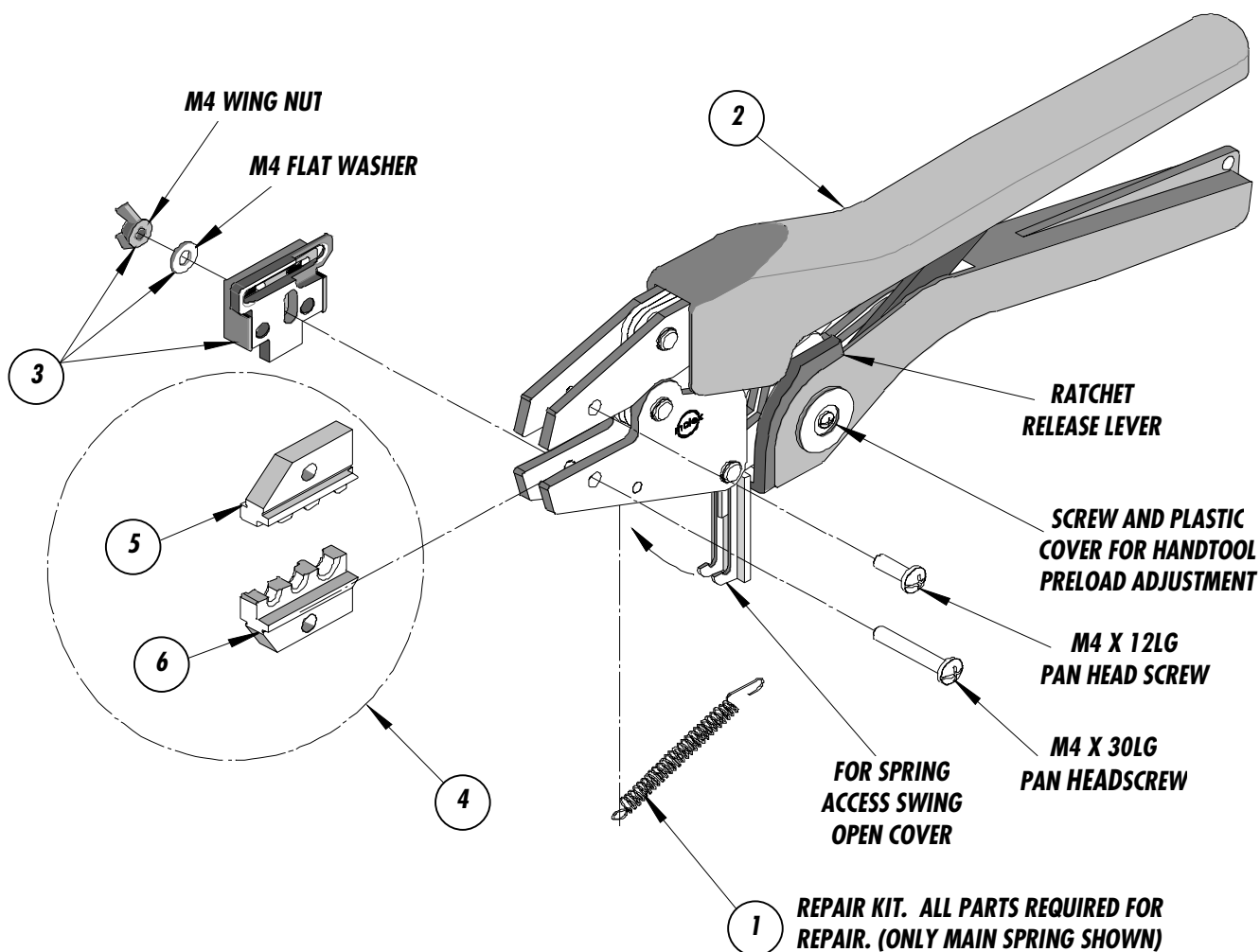
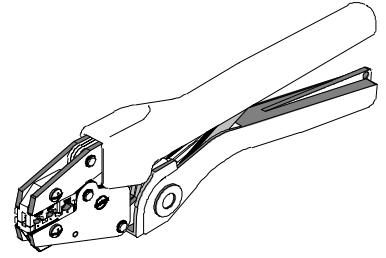

Figure 8



Certificate of Calibration

Tool Order Number _____

Tool Eng. Number _____

Tool Revision _____

Serial Number _____

Date of Manufacture _____

Handle Load Range at 1 inch from the Tips = _____

Actual = _____

Pin Gauge of Conductor Nest/Nests or Slug height if the nest is the "F" Crimp style.

Range Conductor Nest # 1 = _____ **Actual =** _____

Range Conductor Nest # 2 = _____ **Actual =** _____

Range Conductor Nest # 3 = _____ **Actual =** _____

Technician _____

Date of Calibration _____

Calibration should be done every 5,000 cycles or 3 months.

Tools should be lubricated during this operation.

**Molex Application Tooling Group
1150 E. Diehl Road
Naperville, IL 60563
Tel: (630) 969-4550
Fax: (630) 505-0049**