

<h1 style="margin: 0;">66079</h1>	<h2 style="margin: 0;">OPTICALLY COUPLED DIGITAL FILTER</h2>	<p style="margin: 0;">OPTOELECTRONIC PRODUCTS DIVISION</p>
-----------------------------------	--	---

<p>Features:</p> <ul style="list-style-type: none"> DSCC Approved 916761HXX 10 MBd typical Meets Tempest EMI/RFI emanation criteria TTL compatible input and output RFI Rejection 80dB to 1GHz Faraday shield to provide high common mode rejection 	<p>Applications:</p> <ul style="list-style-type: none"> Military and space Secure communication systems Isolated receiver input Microprocessor system interface Digital isolation for A/D, D/A converters
--	---

DESCRIPTION

The **66079** Optically Coupled Digital Filter consists of an LED optically coupled to a high speed, high gain inverting detector gate. Maximum isolation can be achieved while providing a TTL output capable of switching with propagation delays of 55nS typical. The 66079 is a hermetically sealed package which is threaded in order to provide convenient bulkhead mounting and is available in standard and screened versions or tested to customer specifications. The 66079-001 is a hermetically sealed package which can be soldered or press-fit mounted and is also available in standard and MIL-PRF-38534 screened versions or tested to customer specifications.

ABSOLUTE MAXIMUM RATINGS

Storage Temperature.....	-65°C to +150°C
Operating Free-Air Temperature Range	-55°C to +125°C
Lead Solder Temperature.....	260°C for 10s (1.6mm below seating plane)
Peak Forward Input Current	40mA (1ms duration)
Forward Input Current Continuous	20mA
Supply voltage - V _{CC}	7V(1 minute maximum)
Output Current - I _O	25mA
Output Power Dissipation	40mW
Output Voltage - V _O	7V
Total Power Dissipation	175mW

Package Dimensions

Schematic Diagram

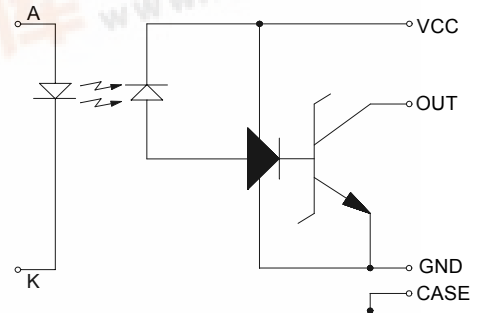
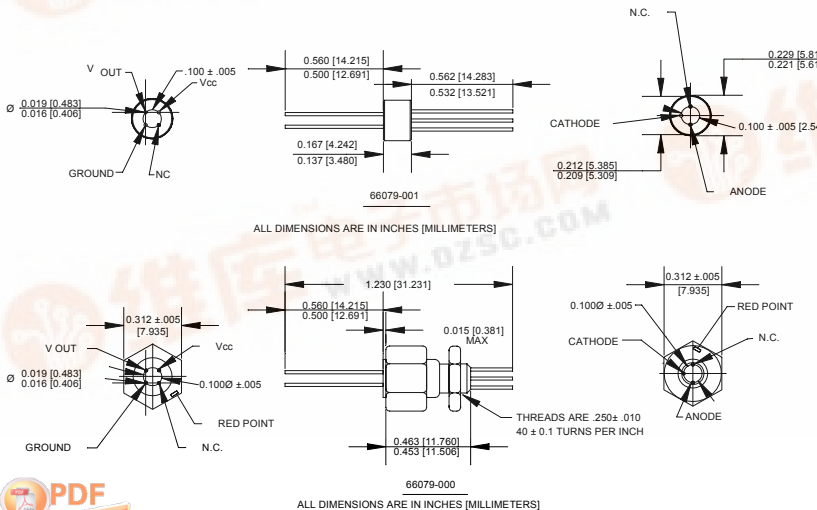

NOTE:
A.01 TO 0.1 μF BYPASS
CAPACITOR MUST BE
CONNECTED BETWEEN
V_{CC} AND GROUND.



ELECTRICAL CHARACTERISTICS $T_a = -55^{\circ}\text{C}$ to $+125^{\circ}\text{C}$ unless otherwise specified.

PARAMETER	SYMBOL	MIN	TYP	MAX	UNITS	TEST CONDITIONS	NOTE
High Level Output Current	I_{OH}		5	250	μA	$V_{CC} = 5.5\text{V}$, $V_O = 5.5\text{V}$, $I_F = 250\mu\text{A}$	
Low Level Output Voltage	V_{OL}		0.5	0.6	V	$V_{CC} = 5.5\text{V}$, $I_F = 10\text{mA}$ I_{OL} (Sinking) = 10mA	
High Level Supply Current	I_{CCH}		10	20	mA	$V_{CC} = 5.5\text{V}$, $I_F = 0$ (Both Channels)	
Low Level Supply Current	I_{CCL}		20	30	mA	$V_{CC} = 5.5\text{V}$, $I_F = 20\text{mA}$ (Both Channels)	
Input Forward Voltage	V_F		1.5	1.75	V	$I_F = 20\text{mA}$	
Input Reverse Breakdown Voltage	BV_R	5			V	$I_R = 10\mu\text{A}$	
Input-Output Insulation Leakage Current	I_{I-O}			1.0	μA	$V_{I-O} = 1500\text{Vdc}$, Relative Humidity = 45% $T_a = 25^{\circ}\text{C}$, $t = 5\text{s}$	
Propagation Delay Time To High Output Level	t_{PLH}		65	100	ns	$R_L = 510\Omega$, $C_L = 15\text{pF}$. $I_F = 13\text{mA}$, $t_a = 25^{\circ}\text{C}$	
Propagation Delay Time To Low Output Level	t_{PHL}		55	100	ns	$R_L = 510\Omega$, $C_L = 15\text{pF}$. $I_F = 13\text{mA}$, $t_a = 25^{\circ}\text{C}$	

TYPICAL CHARACTERISTICS $T_a = 25^{\circ}\text{C}$, $V_{CC} = 5\text{V}$ EACH CHANNEL

PARAMETER	SYMBOL	MIN	TYP	MAX	UNITS	TEST CONDITIONS	NOTE
Input Capacitance	C_{IN}		60			$V_F = 0$, $f = \text{MHz}$	
Input to Case Capacitance	C_{IC}		2	5	pF	$V_F = 0$, $f = \text{MHz}$	
Input Diode Temperature Coefficient	ΔV_F		-1.9		mV/ $^{\circ}\text{C}$	$I_F = 20\text{mA}$	
Capacitance (Input-Output)	C_{I-O}		1	3	pF	$f = 1\text{MHz}$	
Output Rise-Fall Time (10-90%)	t_r , t_f		35		ns	$R_L = 510\Omega$, $C_L = 50\text{pF}$ $I_F = 13\text{mA}$	
Common Mode Transient Immunity at High Output Level	CM_H	1000	10000		V/ μs	$V_{CM} = 10\text{V}$ (peak), V_O (min) = 2V, $R_L = 510\Omega$, $I_F = 0\text{mA}$	1
Common Mode Transient Immunity at Low Output Level	CM_L	1000	10000		V/ μs	$V_{CM} = 10\text{V}$ (peak), V_O (max) = 0.8V, $R_L = 510\Omega$, $I_F = 10\text{mA}$	2

NOTES:

- CM_H is the max. tolerable common mode transient to assure that the output will remain in a high logic state (i.e. $V_O > 2.0\text{V}$).
- CM_L is the max. tolerable common mode transient to assure that the output will remain in a low logic state (i.e. $V_O < 0.8\text{V}$).

RECOMMENDED OPERATING CONDITIONS:

PARAMETER	SYMBOL	MIN	MAX	UNITS
Input Current, Low Level Each Channel	I_{FL}	0	250	μA
Input Current, High Level Each Channel	I_{FH}	12.5	20	mA
Supply Voltage	V_C	4.5	5.5	V
Fan Out (TTL Load) Each Channel	N		6	
Operating Temperature	T_A	-55	125	$^{\circ}\text{C}$

SELECTION GUIDE

PART NUMBER	PART DESCRIPTION
66079-000	With housing, with 100% screening
66079-000C	DSCC Drawing # 5962-916761HXX, with housing
66079-001	Without housing, with 100% screening
66079-001C	DSCC Drawing #5962-916760HXX (without housing)
66079-002	With housing, commercial mil-temp (-55 $^{\circ}\text{C}$ to +125 $^{\circ}\text{C}$)
66079-003	Without housing, commercial mil-temp (-55 $^{\circ}\text{C}$ to +125 $^{\circ}\text{C}$)
66079-004	Without housing, commercial extended temp (-40 $^{\circ}\text{C}$ to +80 $^{\circ}\text{C}$)
66079-004H	With housing, commercial extended temp (-40 $^{\circ}\text{C}$ to +80 $^{\circ}\text{C}$)
66079-005	Without housing, commercial temp (0 $^{\circ}\text{C}$ to +70 $^{\circ}\text{C}$)
66079-005H	With housing, commercial temp (0 $^{\circ}\text{C}$ to +70 $^{\circ}\text{C}$)