



DESCO WORKSURFACE MAT SELECTION CHART

	Mat Type	Material Construction	Resistance Classification (RTT in Ohms)	Surface	Best Application	Special Features
Rubber	T2	Two-layer rubber 0.060" thick	Dissipative Side $10^6 - 10^8$ Conductive Side $<10^4$	Light Texture	Where chemical and hot solder are used	Highly durable, heat/chemical and abrasion resistant, dual purpose; both sides may be used Compatible with Continuous Monitors
	UC	Two-layer rubber 0.080" thick 0.250" thick	Dissipative Side $10^6 - 10^8$ Conductive Side $<10^5$	Smooth	Clean Room; cushioning for products sensitive to shock	Durable heat and chemical resistant worksurface; cushioned bottom layer provides energy absorption; designed for cleanroom Compatible with Continuous Monitors
	J	Single-layer rubber 0.125" thick	Dissipative $10^5 - 10^7$	Foam	Cafeteria Cart Trays	Anti-skid; cushioning protects fragile parts. Easy to clean surface
Multi-Layer Vinyl	Z2	Three-layer conductive vinyl 0.125" thick	Dissipative $10^6 - 10^8$	Light Emboss	Where vinyl durability is OK, compatible with continuous monitors	Conductive inner layer provides fast, reliable path to ground while reducing alternative, unintended paths to ground Compatible with Continuous Monitors
	O	Three-layer vinyl 0.375" thick	Dissipative $10^6 - 10^8$	Smooth	Where vinyl durability is OK, cushioning for products	Highly durable, heat/chemical and abrasion resistant, dual purpose; both sides may be used Compatible with Continuous Monitors
Homogeneous Vinyl	B	Single-layer vinyl 0.060" thick 0.100" thick	Dissipative $10^7 - 10^8$	Light Texture	Economical choice	Inexpensive, durable, easy to cut, reversible. Minimum recommended tech requirement range of \$20.20.
Laminate	Micostat®	High pressure laminate 0.038" thick	Dissipative $10^6 - 10^9$	Smooth	Laminate, where chemical and hot solder are used	Superior heat, chemical, cut resistant Compatible with Continuous Monitors

FACTORS IN SELECTING MATS:

1. Is the mat being used on a workbench or floor?
2. Is there a preference for static dissipative or conductive?
3. What is the function of the mat: Remove electrostatic charge? Protect benches? Provide cushioning? All?
4. Is color important? Does it have to match an existing mat?
5. Does the mat need to meet a particular specification?
6. If a floor mat is required, does the customer know that foot grounders are needed?
7. What will the mat be subjected to? Heat via soldering? Chemicals?
8. Is quality and warranty of the material important?
9. What durability is desired?
10. Is price important? But price is one thing and value, when you consider the above points, is quite another.



DESCO

WORKSURFACE MAT MATERIALS

STATFREE T2™ PREMIUM DISSIPATIVE DUAL LAYER RUBBER

Mat Top Kits	Beige	Blue	Dark Grey	Dark Blue
24" x 36" (0.6m x 0.9m)	66030	66040	66050	66051
24" x 48" (0.6m x 1.2m)	66035	66045	66055	66056

Item #14213 Common Point Ground Kit is included with Mat Top Kits.

Rolls	Beige	Blue	Dark Grey	Dark Blue
24" x 40' (0.6m x 12.2m)	66060	66070	66080	66081
30" x 40' (0.76m x 12.2m)	66115	66110	66105	66106
36" x 40' (0.76m x 12.2m)	66065	66075	66085	66086
48" x 40' (1.2m x 12.2m)	66090	66095	66100	66101

Grounding Hardware is not included with rolls. See pages 20-23 for hardware.

- **Durable rubber material, dissipative on one side and conductive on the other**
Versatile and long-lasting product; use as a dissipative worksurface table mat. Bottom conductive layer provides reliable path to ground
- **RTT: 10⁶ - 10⁸ (Dissipative Side) and <10⁴ (Conductive Side) Ohms per ESD S4.1**
Slows charge removal; meets minimum recommended worksurface requirements of ANSI/ESD S20.20 and recommendations of ESD 4.1
- **RTG: 10⁶ - 10⁸ (Dissipative Side) and <10⁴ (Conductive Side) Ohms per ESD S4.1**
- **Thickness: 0.060" (1.5mm)**
- **Made in America**

Drawing PM-104, Technical Bulletin TB-2000

66030,66040, 66050, 66051

Premium Worksurface Mat; Ideal for Soldering or Assembly Areas

Compatible for use with continuous monitors

Look for the Statfree® brand on Desco ESD matting - for your protection and auditing purposes

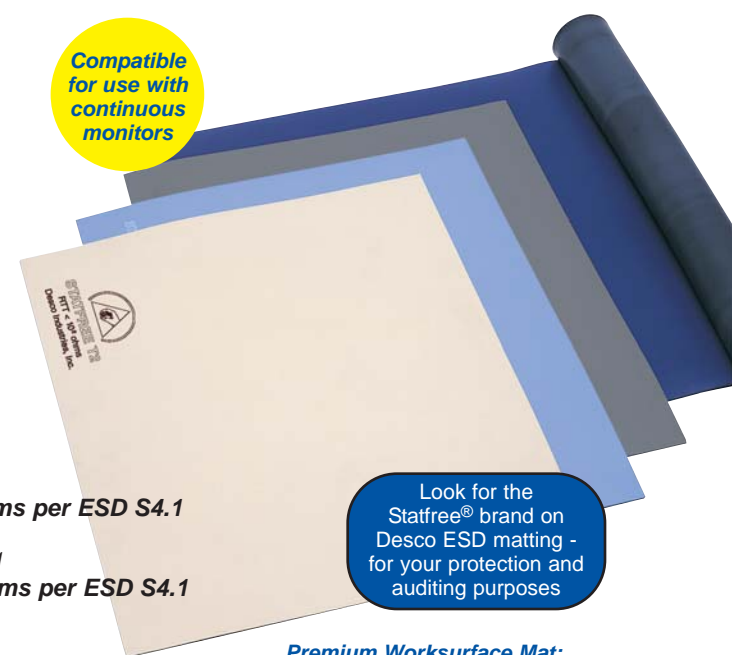

STATFREE UC™ DISSIPATIVE DUAL LAYER ULTRA CLEAN RUBBER

Rolls	Blue
30" x 40' (0.76m x 12.2m), 2mm thick	66300
24" x 30' (0.61m x 9.1m), 6mm thick	66340
30" x 30' (0.76m x 9.1m), 6mm thick	66350

Grounding Hardware is not included with rolls. See pages 20-23 for hardware.

- **Developed for cleanrooms; minimal outgassing**
This product was tested by a hi-tech manufacturer who approved it for Class 100 Clean Room use. The FTIR testing producing no detectable levels of Silicone or DOP.
- **RTT: 10⁶ - 10⁸ (Blue top layer) and <10⁶ (Black bottom layer) Ohms per ESD S4.1**
Slows charge removal; meets minimum recommended worksurface requirements of ANSI/ESD S20.20, recommendations of ESD 4.1 a
- **Thickness: 0.080" (2mm), 0.250" (6mm)**
- **Proprietary product**

Drawing PM-121, Technical Bulletin TB-2000

For detailed information on all Desco worksurface mats: www.desco.com/catalog

Compatible for use with continuous monitors



STATFREE J™ DISSIPATIVE SHOCK RESISTANT FOAM RUBBER

Mat Top Kit	Black
16" x 24" (0.4m x 0.6m)	45010

Roll	Black
24" x 40' (0.6m x 12.2m)	45000

Grounding Hardware is not included with rolls. See pages 20-23 for hardware.

- **Resilient non-skid natural foam rubber**
Perfect for cafeteria trays and cart shelves
- **Custom sizes available**
To fit your application
- **RTT: 10⁵ - 10⁷ Ohms per ESD-S4.1**
- **RTG: 10⁵ - 10⁷ Ohms per ESD-S4.1**
- **Thickness: 0.125" (3.2mm)**
- **Made in America**

Drawing PM-114, Technical Bulletin TB-2000

ESD Cushioning Protects Fragile Parts



See our products being Made in America on our web site: www.desco.com/factory



45010



DESCO

WORKSURFACE MAT MATERIALS

STATFREE Z2™ DISSIPATIVE 3 LAYER VINYL

Mat Top Kits

24" x 36" (0.6m x 0.9m)	Blue 42460	Grey 42470
24" x 48" (0.6m x 1.2m)	Blue 42465	Grey 42475

Item #14213 Common Point Ground Kit is included with Mat Top Kits.

Rolls

24" x 50' (0.6m x 15.2m)	Blue 42500	Grey 42515
30" x 50' (0.76m x 15.2m)	Blue 42516	Grey 42517
36" x 50' (0.9m x 15.2m)	Blue 42518	Grey 42519
48" x 50' (1.2m x 15.2m)	Blue 42520	Grey 42530

Grounding Hardware is not included with rolls. See pages 20-23 for hardware.

- **Heat fused vinyl composite with top and bottom dissipative vinyl layers and conductive grid mesh inner layer**
Resists delamination; reduces unintended alternative ground paths.
Meets ESD worksurface requirements of ANSI/ESD S20.20 and recommendation of ESD S4.1
- **RTT: 10⁶ - 10⁸ Ohms per ESD S4.1**
- **RTG: 10⁶ - 10⁸ Ohms per ESD S4.1**
- **Thickness: 0.125" (3.2mm)**
- **Made in America**

Drawing PM-112 and Technical Bulletin TB-2000



42460, 42470

STATFREE O™ DISSIPATIVE 3-LAYER VINYL

Rolls

24" x 60' (0.6m x 18.3m)	Blue 65000
30" x 60' (0.8m x 18.3m)	Blue 65001
36" x 60' (0.9m x 18.3m)	Blue 65002

Grounding Hardware is not included with rolls. See pages 20-23 for hardware.

- **Thick, energy absorbing**
Excellent cushioning mat for trays, carts and benches. As worksurface or shelf mat, protects parts susceptible to physical shock
- **RTT: 10⁶ - 10⁸ Ohms per ESD S4.1**
- **RTG: 10⁶ - 10⁸ Ohms per ESD S4.1**
- **Thickness: 0.375" (9.5mm)**
- **Made in America**

Drawing PM-116 and Technical Bulletin TB-2000



65000

STATFREE B™ DISSIPATIVE HOMOGENEOUS VINYL

Mat Top Kit

24" x 36" (0.6m x 0.9m), 0.100 thick	Beige 16201	Blue 16213
24" x 48" (0.6m x 1.2m), 0.100 thick	Beige 16202	Blue 16214

Item #14213 Common Point Ground Kit is included with Mat Top Kits.

Rolls

24" x 40' (0.6m x 12.2m), 0.100 thick	Beige 16250	Blue 16260
24" x 100' (0.6m x 30.5m), 0.100 thick	Beige 16251	Blue 16265
30" x 40' (0.76m x 12.2m), 0.100 thick	Beige 16255	Blue 16266
30" x 100' (0.76m x 30.5m), 0.100 thick	Beige 16280	Blue 16282
36" x 40' (0.9m x 12.2m), 0.100 thick	Beige 16281	Blue 16267
36" x 100' (1.2m x 30.5m), 0.100 thick	Beige 16281	Blue 16283
48" x 40' (1.2m x 12.2m), 0.100 thick	Beige 16281	Blue 16283
24" x 100' (0.6m x 30.5m), 0.060 thick	Beige 16290	Blue 16291
30" x 100' (0.76m x 30.5m), 0.060 thick	Beige 16291	Blue 16291
36" x 100' (0.9m x 30.5m), 0.060 thick	Beige 16292	Blue 16292
48" x 100' (1.2m x 30.5m), 0.060 thick	Beige 16293	Blue 16293

Grounding Hardware is not included with rolls. See pages 20-23 for hardware.

- **<10⁹ ohm resistance**
Meets the minimum recommended worksurface requirement of ANSI/ESD S20.20
- **RTT: 10⁷ - 10⁸ Ohms per ESD S4.1**
- **RTG: 10⁷ - 10⁸ Ohms per ESD S4.1**
- **Thickness: 0.100" (2.5mm) and 0.060" (1.5mm)**
- **Made in America**

Drawing PM-078 and Technical Bulletin TB-2000

0.060" Thick Material is Economical
Choice for General Assembly or
Cafeteria-Style Trays

IMPROVED
Now meets
minimum S20.20
requirement

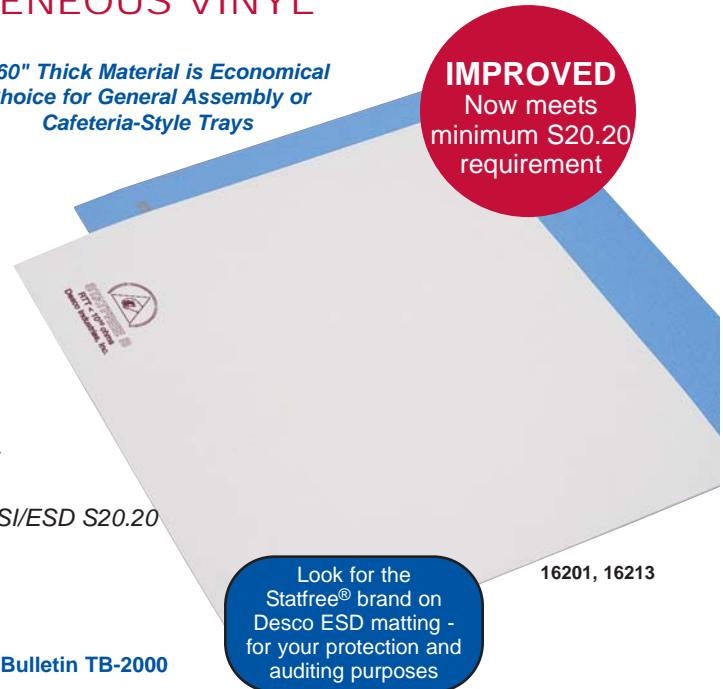

16201, 16213





MICASTAT® DISSIPATIVE LAMINATE

Sheet Size	Beige	Blue	Grey	White
30" x 10' (0.8m x 3.0m)	10200	10180	10290	10240
30" x 12' (0.8m x 3.7m)	10202	10181	10291	10242
36" x 8' (0.9m x 2.4m)	10203	10182	10292	10243
36" x 10' (0.9m x 3.0m)	10204	10183	10293	10244
36" x 12' (0.9m x 3.7m)	10206	10184	10294	10246
48" x 8' (1.2m x 2.4m)	10208	10185	10295	10248
48" x 12' (1.2m x 3.7m)	10212	10187	10297	10252
60" x 12' (1.5m x 3.7m)	10215	10190	10300	10255

Grounding hardware is not included. See pages 20-23 for hardware.

Mat Top Size	Beige	Blue	Grey
24" x 36" (0.6m x 0.9m)	10310	10344	10342
24" x 48" (0.6m x 1.2m)	10350	10384	10382

Item #09826 Common Point Ground Cord is included.

Mat top kits feature 1.5" radiused corners, 10mm snap, and peel and stick installation tape.

- **High pressure laminate**
Resistant to hot solder and most solvents; static control properties will continue for the lifetime of the material. Exceeds NEMA standards for wear resistance.
- **RTT: 10⁶ - 10⁹ Ohms per ESD S4.1**
- **RTG: 10⁶ - 10⁹ Ohms per ESD S4.1**
- **Thickness: 0.038" (0.97mm)**
- **Made in America**

Drawing 10200 and Technical Bulletin TB-2091

LAMINATE GROUNDING SYSTEM

14240 Laminate Grounding System

- **Made in America**
- **Common point ground system for benches with laminate tops**
Includes one 10 ft. (3.0m) grounding wire with one megohm resistor and ring terminal, and one grounding bolt assembly with single wrist strap banana jack connection terminal.

Drawing 14240 and Technical Bulletin TB-2091

Flush Mount Laminate Ground Insert

14246 Flush Mount Laminate Ground Insert with 09740 Bench Ground
 14244 Flush Mount Laminate Ground Insert
 14242 Installation Tool for Flush Mount Insert

- **Made in America**
- **Flush-to-the-Surface Ground for Static Dissipative Laminate such as Micastat®**
Makes a direct connection with the conductive grounding layer of the laminate

Drawing 14242 and Technical Bulletin TB-2091

CARPET GRIPPER TAPE

45050 Carpet Gripper Tape, 1" x 25 yard Roll

- **Flexible hook tape on one side**
Secures to carpet
- **Adhesive tape on the other side**
Secures to mat
- **Made in America**

Drawing 45050

DOUBLE SIDED ADHESIVE TAPE

45015 Double Sided Adhesive Tape, 2" x 750' Roll

- **Pressure sensitive adhesive with release liner**
Use on mats that slide around or curl and create a tripping hazard; great choice for securing mats to metal carts and workstation surfaces.
- **Made in America**

Drawing 45015

Web Site: www.desco.com • Phone: (909) 627-8178 • Fax: (909) 627-7449

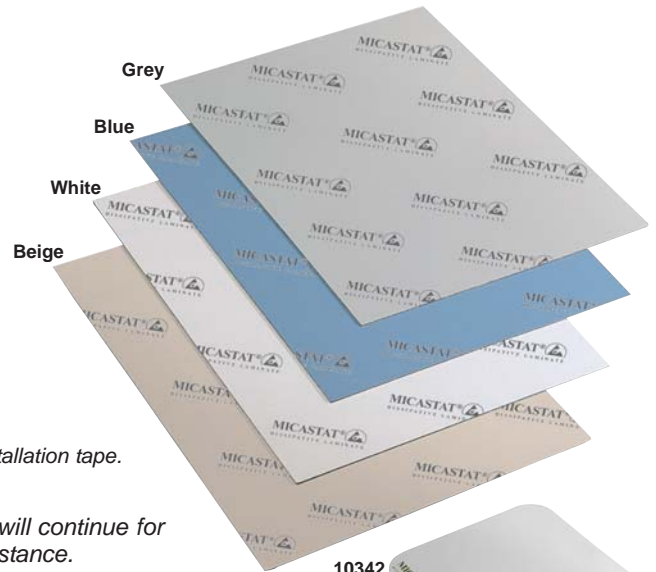

Micastat® has Lifetime Electricals
 Micastat® has a physical, patented, carbon inner sheet layer that provides its electrical performance. This carbon layer and electrical properties will exist until it is physically removed or destroyed.

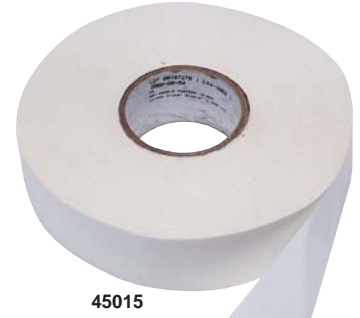
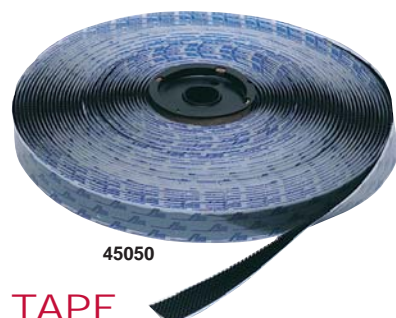
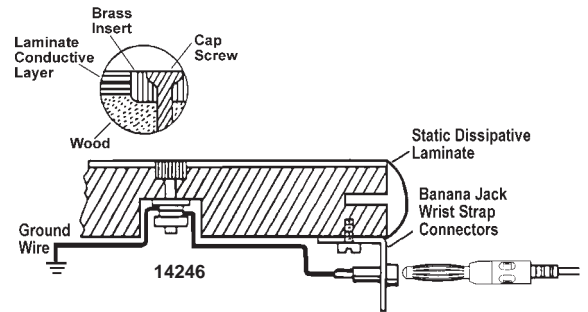
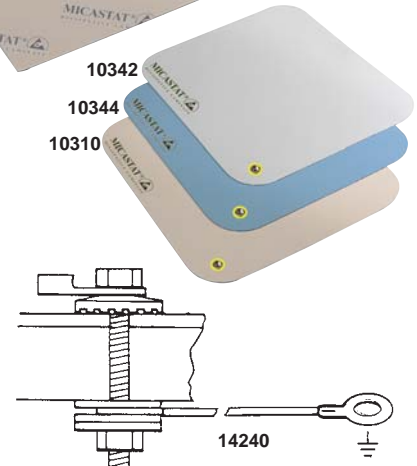

For detailed information on all Desco worksurface mats:
www.desco.com/catalog

See our products being
Made in America
 on our web site:
www.desco.com/factory





Desco's Custom Capabilities



We can solve your unique product requirements with our state-of-the-art automated cutting and laser engraving equipment. If you need mats that are cut and marked to your specifications, we can do it. There are virtually no limitations to our custom mat capabilities.

Mat cutting and laser engraving machine shown at left.

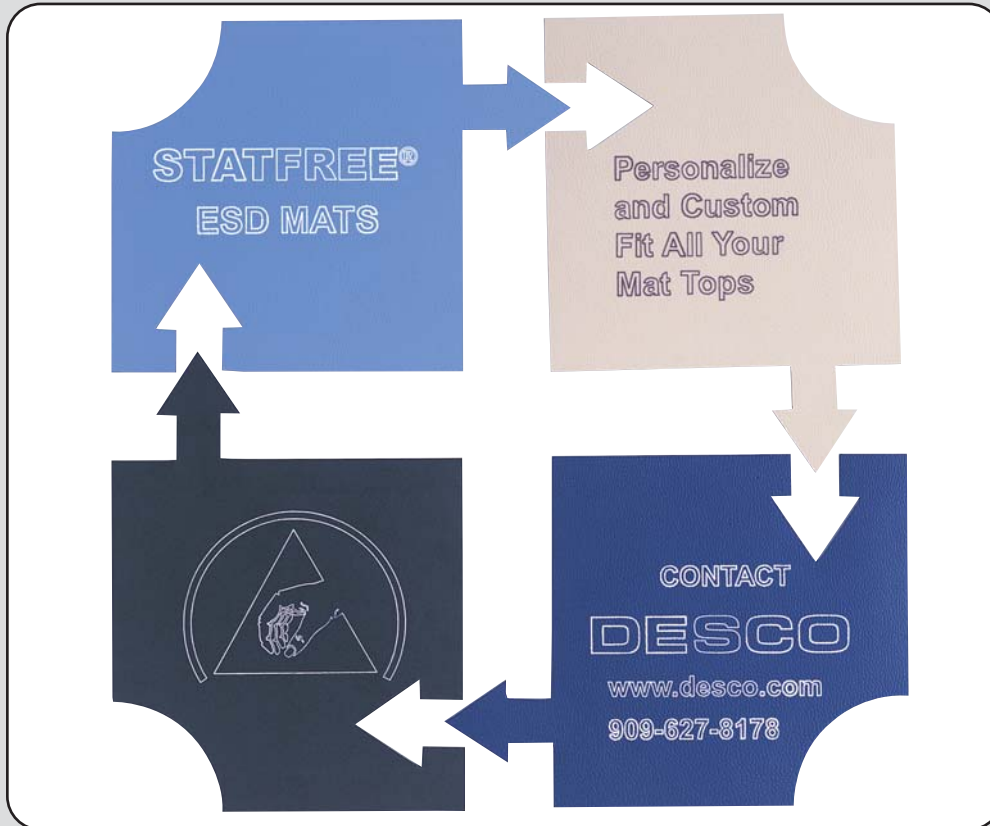

Automated Mat Cutter

Desco's automated mat cutter can cut with accuracy and repeatability to within thousandths of an inch. In addition to being able to cut all our mats, it can cut virtually any material, including fiberglass, carbon fiber, nylon, Mylar, neoprene, Kevlar, Nomex, foam, mesh, canvas, and tubular knit. There are few limitations to the capabilities of our automated mat cutter. We can accommodate just about any pattern you desire.

Laser Engraving

Desco's Laser Engraver makes available the production of a countless number of characters, symbols, and private label branding. We can easily put your logo, address, or other information on any of our mats. The laser creates permanent markings that do not easily rub, wash, or abrade off. Laser etching is more durable than offset/silk screen printing and the end result is markings that are UV/weather and chemical resistant. Custom marks on products, such as ID number, bar coding, and date coding are also possible.

