Preliminary

HD66750/1

(128 x 128-dot Graphics LCD Controller/Driver with
Four-grayscale Functions)

HITACHI

Rev 0.7
July 26th, 1999

Description

The HD66750/1, dot-matrix graphics LCD controller and driver LSI, displays 128-by-128-dot graphics for four monochrome grayscales. Since the HD66750/1 incorporates bit-operation functions and a 16-bit high-speed bus interface, it enables efficient data transfer and high-speed rewriting of data in the graphics RAM. The following functions allow the user to easily see a variety of information: a smooth scroll display function that fixed-displays a part of the graphics icons and perform vertical smooth scrolling of the remaining bit-map areas, a double-height display function, and a hardware-supported window cursor display function.

The HD66750/1 has various functions to reduce the power consumption of an LCD system such as low-voltage operation of 1.8 V min., a booster to generate maximum seven-times LCD drive voltage from the supplied voltage, and voltage-followers to decrease the direct current flow in the LCD drive bleeder-resistors. Combining these hardware functions with software functions, such as a partial display with low-duty drive and standby and sleep modes, allows precise power control. The HD66750/1 is suitable for any mid-sized or small portable battery-driven product requiring long-term driving capabilities, such as digital cellular phones supporting a WWW browser, bidirectional pagers, and small PDAs.

Features

- 128 × 128-dot graphics display LCD controller/driver for four monochrome grayscales
- Fixed display of graphics icons (pictograms)
- 16-/8-bit high-speed bus interface capability
- Bit-operation functions for graphics processing incorporated:
 - Write-data mask function in bit units
 - Bit rotation function
 - Bit logic-operation function
- Low-power operation support:
 - $V_{CC} = 1.8$ to 3.6 V (low voltage)
 - $V_{LCD} = 5$ to 15.5 V (liquid crystal drive voltage)
 - Two-, five-, six-, or seven-times booster for liquid crystal drive voltage
 - 64-step contrast adjuster and voltage followers to decrease direct current flow in the LCD drive bleeder-resistors



HD66750/1

- Power-save functions such as the standby mode and sleep mode supported
- Programmable drive duty ratios and bias values displayed on LCD
- 128-segment × 128-common liquid crystal display driver
- n-raster-row AC liquid-crystal drive (C-pattern waveform drive)
- Duty ratio and drive bias (selectable by program)
- Window cursor display supported by hardware
- Vertical smooth scroll
- Partial smooth scroll control (fixed display of graphics icons)
- Vertical double-height display by each display raster-row
- Black-and-white reversed display
- No wait time for instruction execution and RAM access
- Internal oscillation and hardware reset
- Shift change of segment and common driver

Table 1 Programmable Display Sizes and Duty Ratios

Duty Ratio	Optimum Drive Bias	Bit-map Display Area	Graphics Display				
			12 x 12-dot Font Width	12 x 13-dot Font Width	14 x 15-dot Font Width	16 x 16-dot Font Width	8 x 10-dot Font Width
1/16	1/5	128 x 16 dots	1 line x 10 characters	1 line x 10 characters	1 line x 9 characters	1 line x 8 characters	1 line x 16 characters
1/24	1/6	128 x 24 dots	2 lines x 10 characters	1 line x 10 characters	1 line x 9 characters	1 line x 8 characters	2 lines x 16 characters
1/32	1/6	128 x 32 dots	2 lines x 10 characters	2 lines x 10 characters	2 lines x 9 characters	2 lines x 8 characters	3 lines x 16 characters
1/72	1/9	128 x 72 dots	6 lines x 10 characters	5 lines x 10 characters	4 lines x 9 characters	4 lines x 8 characters	7 lines x 16 characters
1/80	1/10	128 x 80 dots	6 lines x 10 characters	6 lines x 10 characters	5 lines x 9 characters	5 lines x 8 characters	8 lines x 16 characters
1/88	1/10	128 x 88 dots	7 lines x 10 characters	6 lines x 10 characters	5 lines x 9 characters	5 lines x 8 characters	8 lines x 16 characters
1/96	1/10	128 x 96 dots	8 lines x 10 characters	7 lines x 10 characters	6 lines x 9 characters	6 lines x 8 characters	9 lines x 16 characters
1/104	1/11	128 x 104 dots	8 lines x 10 characters	8 lines x 10 characters	6 lines x 9 characters	6 lines x 8 characters	10 lines x 16 characters
1/112	1/11	128 x 112 dots	9 lines x 10 characters	8 lines x 10 characters	7 lines x 9 characters	7 lines x 8 characters	11 lines x 16 characters
1/120	1/11	128 x 120 dots	10 lines x 10 characters	9 lines x 10 characters	8 lines x 9 characters	7 lines x 8 characters	12 lines x 16 characters
1/128	1/11	128 x 128 dots	10 lines x 10 characters	9 lines x 10 characters	8 lines x 9 characters	8 lines x 8 characters	12 lines x 16 characters

<Target values>

Total Current Consumption Characteristics (Vcc = 3 V, TYP Conditions, LCD Drive Power Current Included)

Character Display Size	Dot Ratio	R-C Oscillation Frequency	Frame Frequency	Total Power Consumption				
				Internal Logic	LCD Power	Total*	Sleep Mode	Standby Mode
128 x 16 dots	1/16	70 kHz	72 Hz	(15 μ A)	(15 μ A)	Two-times (45 μ A)	(10 μ A)	0.1 μ A
128 x 24 dots	1/24	70 kHz	72 Hz	(15 μ A)	(15 μ A)	Two-times (45 μ A)	(10 μ A)	
128 x 32 dots	1/32	70 kHz	72 Hz	(15 μ A)	(15 μ A)	Two-times (45 μ A)	(10 μ A)	
128 x 72 dots	1/72	70 kHz	71 Hz	(40 μ A)	(18 μ A)	Five-times (130 μ A)	(10 μ A)	
128 x 80 dots	1/80	70 kHz	73 Hz	(40 μ A)	(18 μ A)	Five-times (130 μ A)	(10 μ A)	
128 x 88 dots	1/88	70 kHz	74 Hz	(45 μ A)	(18 μ A)	Five-times (135 μ A)	(10 μ A)	
128 x 96 dots	1/96	70 kHz	74 Hz	(45 μ A)	(20 μ A)	Five-times (145 μ A)	(10 μ A)	
128 x 104 dots	1/104	70 kHz	73 Hz	(45 μ A)	(20 μ A)	Five-times (145 μ A)	(10 μ A)	
128 x 112 dots	1/112	70 kHz	71 Hz	(50 μ A)	(25 μ A)	Six-times (200 μ A)	(10 μ A)	
128 x 120 dots	1/120	70 kHz	76 Hz	(50 μ A)	(25 μ A)	Six-times (200 μ A)	(10 μ A)	
128 x 128 dots	1/128	70 kHz	72 Hz	(50 μ A)	(25 μ A)	Six-times (200 μ A)	(10 μ A)	

Note: When a two-, five-, six-, or seven-times booster is used:
the total power consumption = internal logic current + LCD power current x 2 (two-times booster),
the total power consumption = internal logic current + LCD power current x 5 (five-times booster),
the total power consumption = internal logic current + LCD power current x 6 (six-times booster), and
the total power consumption = internal logic current + LCD power current x 7 (seven-times booster)

Type Name

Types	External Dimensions	COM Driver Arrangement	Display
HD66750TB0	Bending TCP	Both sides of COM (Output from left and right sides of the chip)	Four monochrome grayscale
HCD66750BP	Au-bump chip		
HD66751TB0	Bending TCP	One side of COM	
HCD66751BP	Au-bump chip	(Output from one side of the chip)	

HD66750/1

LCD Family Comparison

Items	HD66705U	HD66717	HD66727
Character display sizes	12 characters x 2 lines	12 characters x 4 lines	12 characters x 4 lines
Graphic display sizes	—	—	—
Grayscale display	—	—	—
Multiplexing icons	40	40	40
Annunciator	Static: 10	Static: 10	Static: 12
Key scan control	—	—	4 x 8
LED control ports	—	—	3
General output ports	—	—	3
Operating power voltages	2.4 V to 5.5 V	2.4 V to 5.5 V	2.4 V to 5.5 V
Liquid crystal drive voltages	3 V to 9 V	3 V to 13 V	3 V to 13 V
Serial bus	Clock-synchronized serial	I ² C, Clock-synchronized serial	I ² C, Clock-synchronized serial
Parallel bus	4 bits, 8 bits	4 bits, 8 bits	—
Liquid crystal drive duty ratios	1/10, 18	1/10, 18, 26, 34	1/10, 18, 26, 34
Liquid crystal drive biases	1/4	1/4, 1/6	1/4, 1/6
Liquid crystal drive waveforms	B	B	B
Liquid crystal voltage booster	Two- or three-times	Two- or three-times	Two- or three-times
Bleeder-resistor for liquid crystal drive	Incorporated (external)	Incorporated (external)	Incorporated (external)
Liquid crystal drive operational amplifier	Incorporated	Incorporated	Incorporated
Liquid crystal contrast adjuster	Incorporated	Incorporated	Incorporated
Horizontal smooth scroll	—	—	—
Vertical smooth scroll	Line unit	Line unit	Line unit
Double-height display	Yes	Yes	Yes
DDRAM	60 x 8	60 x 8	60 x 8
CGROM	9,600	9,600	11,520
CGRAM	32 x 5	32 x 5	32 x 6
SEGRAM	8 x 5	8 x 5	8 x 6
No. of CGROM fonts	240	240	240
No. of CGRAM fonts	4	4	4
Font sizes	5 x 8	5 x 8	5 x 8, 6 x 8
Bit map area	—	—	—
R-C oscillation resistor/ oscillation frequency	External resistor (40, 80 kHz)	External resistor (40-160 kHz)	External resistor (40-160 kHz)
Reset function	External	External	External
Low power control	Partial display off, Oscillation off, Liquid crystal power off	Partial display off, Oscillation off, Liquid crystal power off	Partial display off, Oscillation off, Liquid crystal power off, Key wake-up interrupt
SEG/COM direction switching	SEG only	SEG only	SEG, COM
QFP package	—	—	—
TQFP package	—	—	—
TCP package	TCP-153	TCP-153	TCP-158
Bare chip	Yes	Yes	Yes
Bumped chip	Yes	Yes	Yes
No. of pins	153	153	158
Chip sizes	9.69 x 2.73	10.88 x 2.89	11.39 x 2.89
Pad intervals	120 μm	120 μm	120 μm

LCD Family Comparison (cont)

Items	HD66724	HD66725	HD66726
Character display sizes	12 characters x 3 lines	16 characters x 3 lines	16 characters x 5 lines
Graphic display sizes	72 x 26 dots	96 x 26 dots	96 x 42 dots
Grayscale display	—	—	—
Multiplexing icons	144	192	192
Annunciator	1/2 duty: 144	1/2 duty: 192	1/2 duty: 192
Key scan control	8 x 4	8 x 4	8 x 4
LED control ports	—	—	—
General output ports	3	3	3
Operating power voltages	1.8 V to 5.5 V	1.8 V to 5.5 V	1.8 V to 5.5 V
Liquid crystal drive voltages	3 V to 6.5 V	3 V to 6.5 V	4.5 V to 11 V
Serial bus	Clock-synchronized serial	Clock-synchronized serial	Clock-synchronized serial
Parallel bus	4 bits, 8 bits	4 bits, 8 bits	4 bits, 8 bits
Liquid crystal drive duty ratios	1/2, 10, 18, 26	1/2, 10, 18, 26	1/2, 10, 18, 26, 34, 42
Liquid crystal drive biases	1/4 to 1/6.5	1/4 to 1/6.5	1/2 to 1/8
Liquid crystal drive waveforms	B	B	B
Liquid crystal voltage booster	Single, two-, or three-times	Single, two-, or three-times	Single, two-, three-, or four-times
Bleeder-resistor for liquid crystal drive	Incorporated (external)	Incorporated (external)	Incorporated (external)
Liquid crystal drive operational amplifier	Incorporated	Incorporated	Incorporated
Liquid crystal contrast adjuster	Incorporated	Incorporated	Incorporated
Horizontal smooth scroll	3-dot unit	3-dot unit	—
Vertical smooth scroll	Line unit	Line unit	Line unit
Double-height display	Yes	Yes	Yes
DDRAM	80 x 8	80 x 8	80 x 8
CGROM	20,736	20,736	20,736
CGRAM	384 x 8	384 x 8	480 x 8
SEGRAM	72 x 8	96 x 8	96 x 8
No. of CGROM fonts	240 + 192	240 + 192	240 + 192
No. of CGRAM fonts	64	64	64
Font sizes	6 x 8	6 x 8	6 x 8
Bit map areas	72 x 26	96 x 26	96 x 42
R-C oscillation resistor/ oscillation frequency	External resistor, incorporated (32 kHz)	External resistor, incorporated (32 kHz)	External resistor (50 kHz)
Reset function	External	External	External
Low power control	Partial display off, Oscillation off, Liquid crystal power off, Key wake-up interrupt	Partial display off, Oscillation off, Liquid crystal power off, Key wake-up interrupt	Partial display off, Oscillation off, Liquid crystal power off, Key wake-up interrupt
SEG/COM direction switching	SEG, COM	SEG, COM	SEG, COM
QFP package	—	—	—
TQFP package	—	—	—
TCP package	TCP-146	TCP-170	TCP-188
Bare chip	—	—	Yes
Bumped chip	Yes	Yes	Yes
No. of pins	146	170	188
Chip sizes	10.34 x 2.51	10.97 x 2.51	13.13 x 2.51
Pad intervals	80 μm	80 μm	100 μm

HD66750/1

LCD Family Comparison (cont)

Items	HD66728	(WS available)
		HD66729
Character display sizes	16 characters x 10 lines	—
Graphic display sizes	112 x 80 dots	105 x 68 dots
Grayscale display	—	—
Multiplexing icons	—	—
Annunciator	—	—
Key scan control	8 x 4	—
LED control ports	—	—
General output ports	3	—
Operating power voltages	1.8 V to 5.5 V	1.8 V to 5.5 V
Liquid crystal drive voltages	4.5 V to 15 V	4.0 V to 13 V
Serial bus	Clock-synchronized serial	Clock-synchronized serial
Parallel bus	4 bits, 8 bits	4 bits, 8 bits
Liquid crystal drive duty ratios	1/8, 16, 24, 32, 40, 48, 56, 64, 72, 80	1/8, 16, 24, 32, 40, 48, 56, 64, 68
Liquid crystal drive biases	1/4 to 1/10	1/4 to 1/9
Liquid crystal drive waveforms	B, C	B, C
Liquid crystal voltage booster	Three-, four-, or five-times	Two-, three-, four-, or five-times
Bleeder-resistor for liquid crystal drive	Incorporated (external)	Incorporated (external)
Liquid crystal drive operational amplifier	Incorporated	Incorporated
Liquid crystal contrast adjuster	Incorporated	Incorporated
Horizontal smooth scroll	—	—
Vertical smooth scroll	Line unit	Line unit
Double-height display	Yes	Yes
DDRAM	160 x 8	—
CGROM	20,736	—
CGRAM	1,120 x 8	1,050 x 8
SEGRAM	—	—
No. of CGROM fonts	240 + 192	—
No. of CGRAM fonts	64	—
Font sizes	6 x 8	—
Bit map areas	112 x 80	105 x 68
R-C oscillation resistor/ oscillation frequency	External resistor (70–90 kHz)	External resistor (75 kHz)
Reset function	External	External
Low power control	Partial display off, Oscillation off, Liquid crystal power off, Key wake-up interrupt	Partial display off, Oscillation off, Liquid crystal power off
SEG/COM direction switching	SEG, COM	SEG, COM
QFP package	—	—
TQFP package	—	—
TCP package	TCP-243	TCP-213
Bare chip	—	—
Bumped chip	Yes	Yes
No. of pins	243	213
Chip sizes	13.67 x 2.78	12.23 x 2.52
Pad intervals	70 μm	70 μm

LCD Family Comparison (cont)

Items	HD66741	(Under development)
		HD66750/751
Character display sizes	—	—
Graphic display sizes	128 x 80 dots	128 x 128 dots
Grayscale display	—	Four monochrome grayscales
Multiplexing icons	—	—
Annunciator	—	—
Key scan control	—	—
LED control ports	—	—
General output ports	3	—
Operating power voltages	1.8 V to 5.5 V	1.8 V to 3.6 V
Liquid crystal drive voltages	4.5 V to 15 V	5 V to 15.5 V
Serial bus	Clock-synchronized serial	—
Parallel bus	4 bits, 8 bits	8 bits, 16 bits
Liquid crystal drive duty ratios	1/8, 16, 24, 32, 40, 48, 56, 64, 72, 80	1/16, 24, 72, 80, 88, 96, 104, 112, 120, 128
Liquid crystal drive biases	1/4 to 1/10	1/4 to 1/11
Liquid crystal drive waveforms	B, C	B, C
Liquid crystal voltage booster	Three-, four-, or five-times	Two-, five-, six-, or seven-times
Bleeder-resistor for liquid crystal drive	Incorporated (external)	Incorporated (external)
Liquid crystal drive operational amplifier	Incorporated	Incorporated
Liquid crystal contrast adjuster	Incorporated	Incorporated
Horizontal smooth scroll	—	—
Vertical smooth scroll	Line unit	Line unit
Double-height display	Yes	Yes
DDRAM	—	—
CGROM	—	—
CGRAM	1,280 x 8	4,096 x 8
SEGRAM	—	—
No. of CGROM fonts	—	—
No. of CGRAM fonts	—	—
Font sizes	—	—
Bit map areas	128 x 80	128 x 128
R-C oscillation resistor/ oscillation frequency	External resistor (70–90 kHz)	External resistor (70 kHz)
Reset function	External	External
Low power control	Partial display off, Oscillation off, Liquid crystal power off	Partial display off, Oscillation off, Liquid crystal power off
SEG/COM direction switching	SEG, COM	SEG, COM
QFP package	—	—
TQFP package	—	—
TCP package	TCP-254	TCP-308
Bare chip	—	—
Bumped chip	Yes	Yes
No. of pins	243	308
Chip sizes	14.30 x 2.78	10.97 x 4.13
Pad intervals	70 μm	60 μm

HD66750/1

HD66750/1 Block Diagram

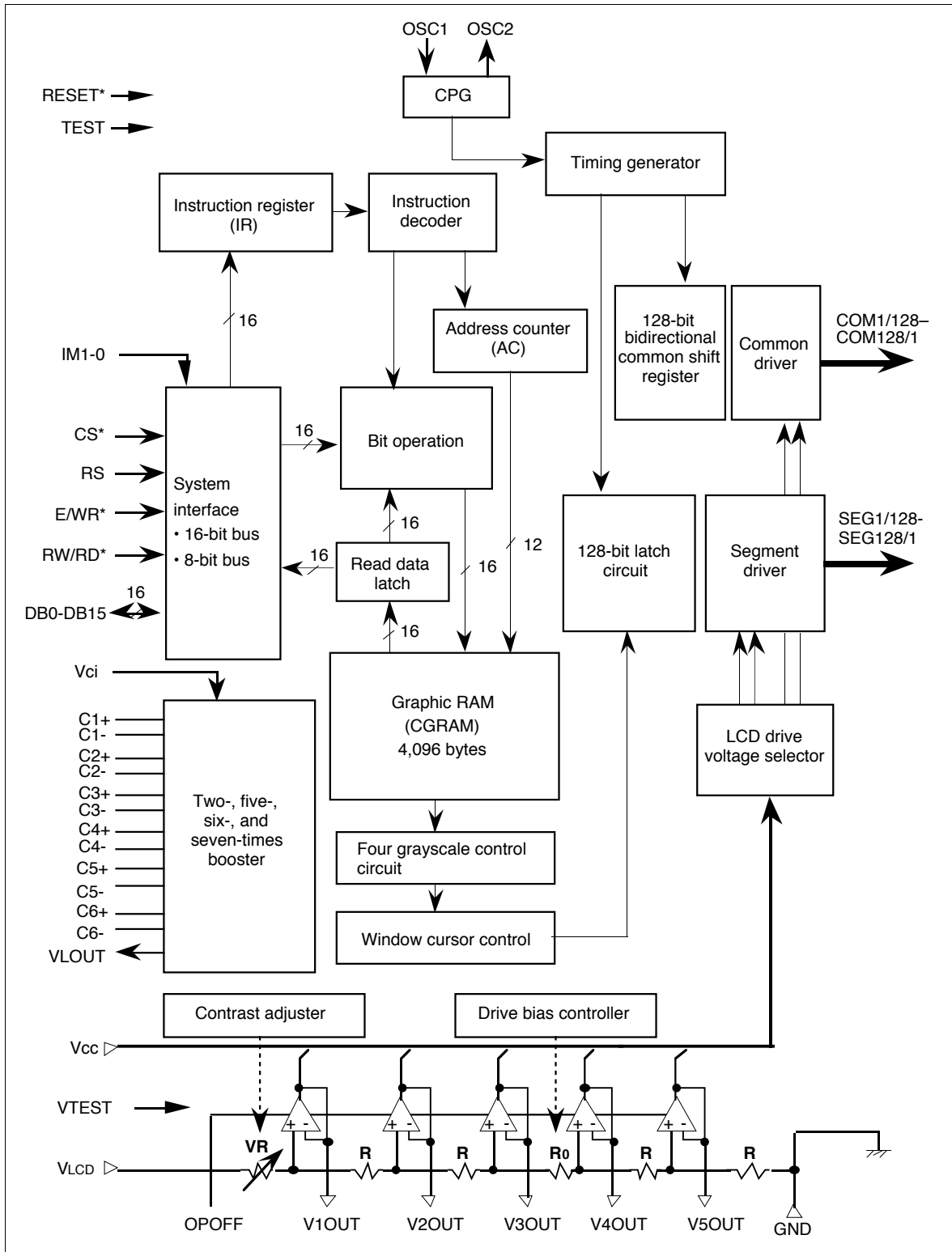

HD66750 Pad Arrangement

- Chip size: 10.97 mm X 4.13 mm
- Pad coordinates: Pad center
- Coordinate origin: Chip center
- Au bump size: 40 μm x 90 μm
Chip corner bump size : 90 μm x 90 μm
(Dummy1, Dummy22, Dummy23 and Dummy 48)
- Au bump pitch: 60 μm (min.)
- Au bump height: 20 μm (typ.)

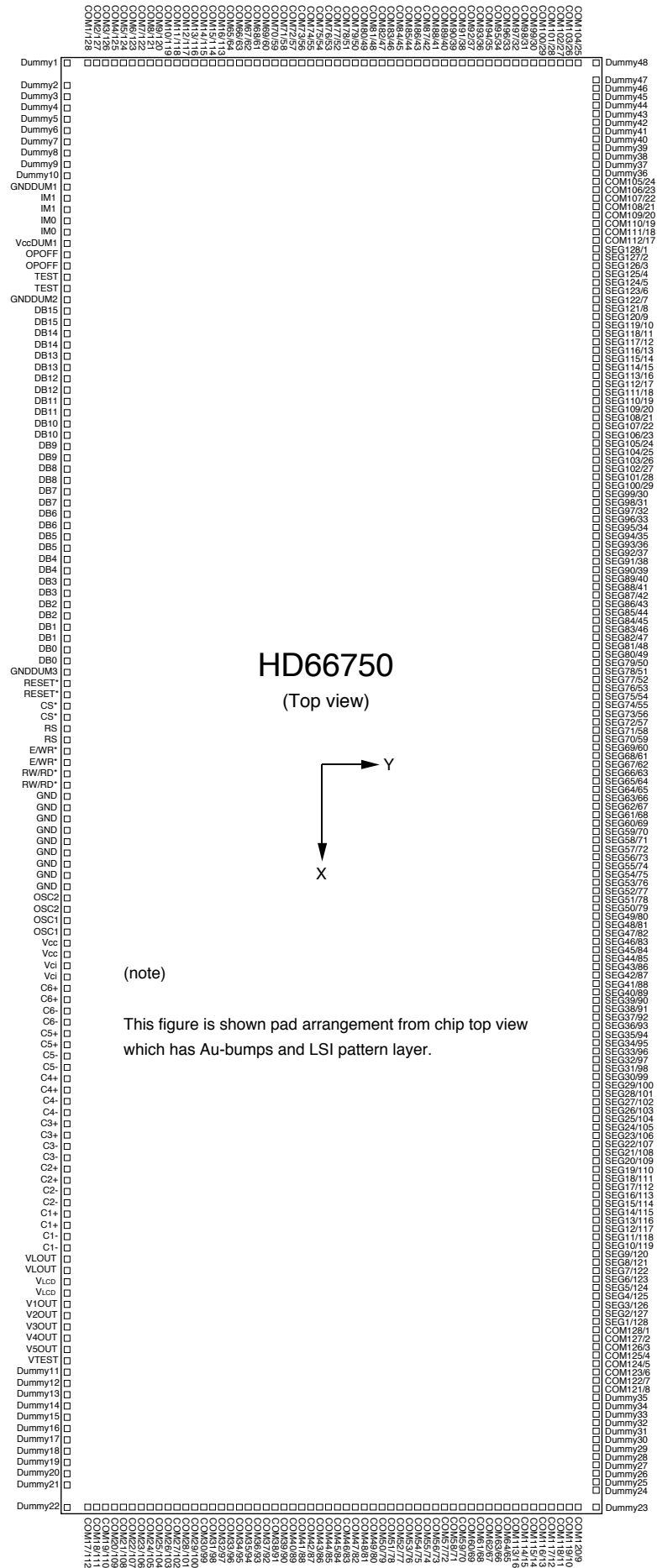

HD66750
(Top view)

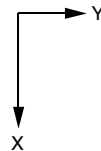

(note)
This figure is shown pad arrangement from chip top view which has Au-bumps and LSI pattern layer.

HD66750/1

HD66751 Pad Arrangement

- Chip size: 10.97 mm X 4.13 mm
- Pad coordinates: Pad center
- Coordinate origin: Chip center
- Au bump size: 40 μm x 90 μm
- Chip corner bump size : 90 μm x 90 μm
(Dummy1, Dummy22, Dummy23 and Dummy 48)
- Au bump pitch: 60 μm (min.)
- Au bump height: 20 μm (typ.)

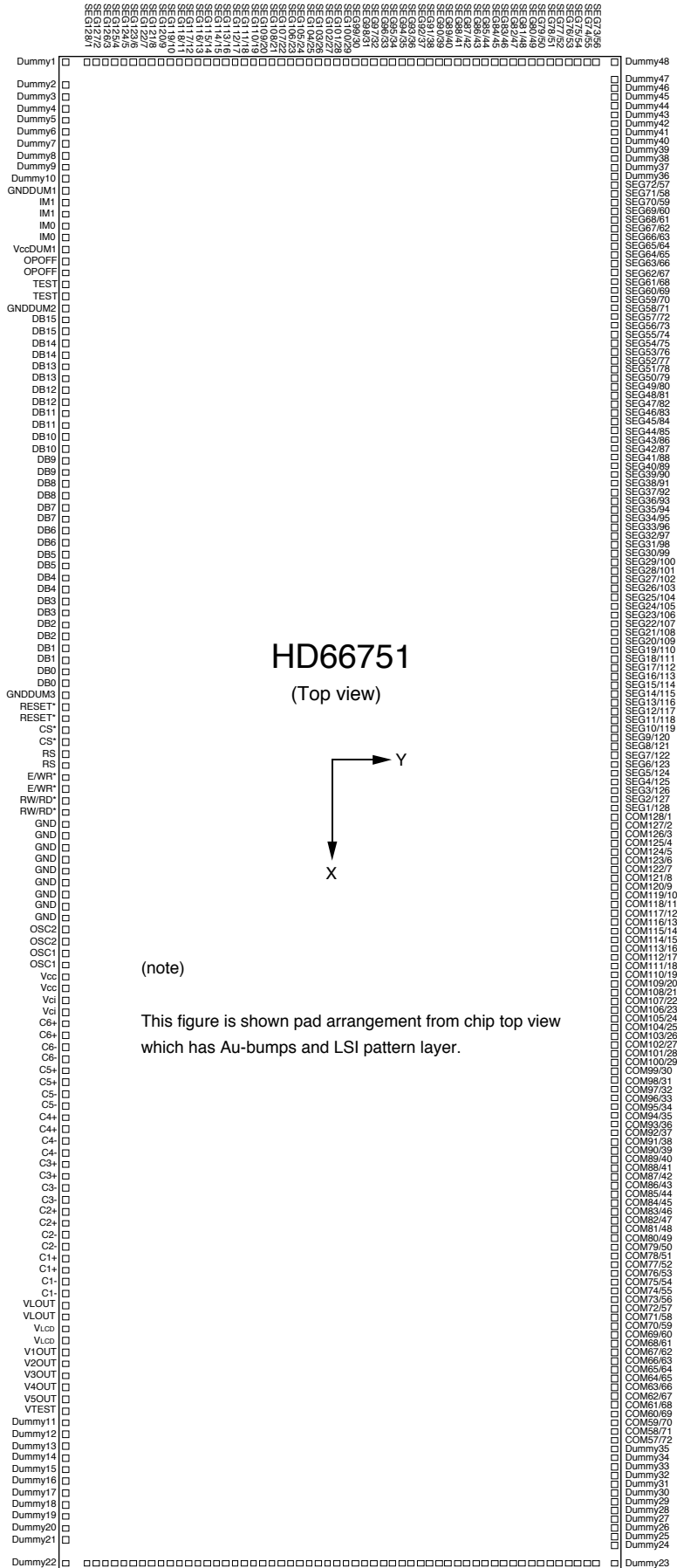

HD66750 Pad Coordinate

PAD NAME	X	Y	PAD NAME	X	Y	PAD NAME	X	Y	PAD NAME	X	Y	PAD NAME	X	Y
1 Dummy1	-5269	-1895	83 C6+	1582	-1849	165 COM54/75	5269	571	247 SEG43/86	1310	1849	329 SEG125/4	-3655	1849
2 Dummy2	-5089	-1895	84 C6-	1703	-1849	166 COM55/74	5269	631	248 SEG44/85	1250	1849	330 SEG126/3	-3715	1849
3 Dummy3	-5029	-1895	85 C6-	1763	-1849	167 COM56/73	5269	691	249 SEG45/84	1190	1849	331 SEG127/2	-3775	1849
4 Dummy4	-4969	-1895	86 C5+	1883	-1849	168 COM57/72	5269	752	250 SEG46/83	1130	1849	332 SEG128/1	-3835	1849
5 Dummy5	-4909	-1895	87 C5+	1943	-1849	169 COM58/71	5269	812	251 SEG47/82	1070	1849	333 COM112/17	-3931	1849
6 Dummy6	-4848	-1895	88 C5-	2063	-1849	170 COM59/70	5269	872	252 SEG48/81	1010	1849	334 COM111/18	-3991	1849
7 Dummy7	-4788	-1895	89 C5-	2124	-1849	171 COM60/69	5269	932	253 SEG49/80	950	1849	335 COM110/19	-4051	1849
8 Dummy8	-4728	-1895	90 C4+	2244	-1849	172 COM61/68	5269	992	254 SEG50/79	890	1849	336 COM109/20	-4111	1849
9 Dummy9	-4668	-1895	91 C4+	2304	-1849	173 COM62/67	5269	1052	255 SEG51/78	829	1849	337 COM108/21	-4171	1849
10 Dummy10	-4608	-1895	92 C4-	2424	-1849	174 COM63/66	5269	1112	256 SEG52/77	769	1849	338 COM107/22	-4232	1849
11 GNDUM1	-4454	-1895	93 C4-	2484	-1849	175 COM64/65	5269	1172	257 SEG53/76	709	1849	339 COM106/23	-4292	1849
12 IM1	-4394	-1895	94 C3+	2605	-1849	176 COM113/16	5269	1232	258 SEG54/75	649	1849	340 COM105/24	-4352	1849
13 IM1	-4334	-1895	95 C3+	2665	-1849	177 COM114/15	5269	1292	259 SEG55/74	589	1849	341 Dummy36	-4428	1895
14 IM0	-4210	-1895	96 C3-	2785	-1849	178 COM115/14	5269	1353	260 SEG56/73	529	1849	342 Dummy37	-4488	1895
15 IM0	-4150	-1895	97 C3-	2845	-1849	179 COM116/13	5269	1413	261 SEG57/72	469	1849	343 Dummy38	-4548	1895
16 VccDUM1	-4086	-1895	98 C2+	2965	-1849	180 COM117/12	5269	1473	262 SEG58/71	409	1849	344 Dummy39	-4608	1895
17 OPOFF	-4026	-1895	99 C2+	3025	-1849	181 COM118/11	5269	1533	263 SEG59/70	348	1849	345 Dummy40	-4668	1895
18 OPOFF	-3966	-1895	100 C2-	3146	-1849	182 COM119/10	5269	1593	264 SEG60/69	288	1849	346 Dummy41	-4728	1895
19 TEST	-3842	-1895	101 C2-	3206	-1849	183 COM120/9	5269	1653	265 SEG61/68	228	1849	347 Dummy42	-4788	1895
20 TEST	-3782	-1895	102 C1+	3326	-1849	184 Dummy23	5269	1653	266 SEG62/67	168	1849	348 Dummy43	-4848	1895
21 GNDUM2	-3722	-1895	103 C1+	3386	-1849	185 Dummy24	5089	1895	267 SEG63/66	108	1849	349 Dummy44	-4909	1895
22 DB15	-3658	-1895	104 C1-	3506	-1849	186 Dummy25	5029	1895	268 SEG64/65	48	1849	350 Dummy45	-4969	1895
23 DB15	-3598	-1895	105 C1-	3566	-1849	187 Dummy26	4969	1895	269 SEG65/64	-48	1849	351 Dummy46	-5029	1895
24 DB14	-3474	-1895	106 VLOUT	3687	-1849	188 Dummy27	4909	1895	270 SEG66/63	-108	1849	352 Dummy47	-5089	1895
25 DB14	-3414	-1895	107 VLOUT	3747	-1849	189 Dummy28	4848	1895	271 SEG67/62	-168	1849	353 Dummy48	-5269	1895
26 DB13	-3290	-1895	108 VLCD	3867	-1849	190 Dummy29	4788	1895	272 SEG68/61	-228	1849	354 COM104/25	-5269	1653
27 DB13	-3230	-1895	109 VLCD	3927	-1849	191 Dummy30	4728	1895	273 SEG69/60	-288	1849	355 COM103/26	-5269	1593
28 DB12	-3106	-1895	110 V1OUT	4047	-1849	192 Dummy31	4668	1895	274 SEG70/59	-348	1849	356 COM102/27	-5269	1533
29 DB12	-3046	-1895	111 V2OUT	4108	-1849	193 Dummy32	4608	1895	275 SEG71/58	-409	1849	357 COM101/28	-5269	1473
30 DB11	-2922	-1895	112 V3OUT	4168	-1849	194 Dummy33	4548	1895	276 SEG72/57	-469	1849	358 COM100/29	-5269	1413
31 DB11	-2862	-1895	113 V4OUT	4228	-1849	195 Dummy34	4488	1895	277 SEG73/56	-529	1849	359 COM99/30	-5269	1353
32 DB10	-2738	-1895	114 V5OUT	4288	-1849	196 Dummy35	4428	1895	278 SEG74/55	-589	1849	360 COM98/31	-5269	1293
33 DB10	-2678	-1895	115 VTEST	4348	-1849	197 COM121/8	4352	1849	279 SEG75/54	-649	1849	361 COM97/32	-5269	1232
34 DB9	-2554	-1895	116 Dummy11	4488	-1895	198 COM122/7	4292	1849	280 SEG76/53	-709	1849	362 COM96/33	-5269	1172
35 DB9	-2494	-1895	117 Dummy12	4548	-1895	199 COM123/6	4232	1849	281 SEG77/52	-769	1849	363 COM95/34	-5269	1112
36 DB8	-2370	-1895	118 Dummy13	4608	-1895	200 COM124/5	4171	1849	282 SEG78/51	-829	1849	364 COM94/35	-5269	1052
37 DB8	-2310	-1895	119 Dummy14	4668	-1895	201 COM125/4	4111	1849	283 SEG79/50	-889	1849	365 COM93/36	-5269	992
38 DB7	-2186	-1895	120 Dummy15	4728	-1895	202 COM126/3	4051	1849	284 SEG80/49	-950	1849	366 COM92/37	-5269	932
39 DB7	-2126	-1895	121 Dummy16	4788	-1895	203 COM127/2	3991	1849	285 SEG81/48	-1010	1849	367 COM91/38	-5269	872
40 DB6	-2002	-1895	122 Dummy17	4848	-1895	204 COM128/1	3931	1849	286 SEG82/47	-1070	1849	368 COM90/39	-5269	812
41 DB6	-1942	-1895	123 Dummy18	4909	-1895	205 SEG1/28	3835	1849	287 SEG83/46	-1130	1849	369 COM89/40	-5269	752
42 DB5	-1818	-1895	124 Dummy19	4969	-1895	206 SEG2/127	3775	1849	288 SEG84/45	-1190	1849	370 COM88/41	-5269	691
43 DB5	-1758	-1895	125 Dummy20	5029	-1895	207 SEG3/126	3715	1849	289 SEG85/44	-1250	1849	371 COM87/42	-5269	631
44 DB4	-1634	-1895	126 Dummy21	5089	-1895	208 SEG4/125	3655	1849	290 SEG86/43	-1310	1849	372 COM86/43	-5269	571
45 DB4	-1574	-1895	127 Dummy22	5269	-1895	209 SEG5/124	3595	1849	291 SEG87/42	-1370	1849	373 COM85/44	-5269	511
46 DB3	-1450	-1895	128 COM17/112	5269	-1653	210 SEG6/123	3535	1849	292 SEG88/41	-1431	1849	374 COM84/45	-5269	451
47 DB3	-1390	-1895	129 COM18/111	5269	-1593	211 SEG7/122	3475	1849	293 SEG89/40	-1491	1849	375 COM83/46	-5269	391
48 DB2	-1266	-1895	130 COM19/110	5269	-1533	212 SEG8/121	3415	1849	294 SEG90/39	-1551	1849	376 COM82/47	-5269	331
49 DB2	-1206	-1895	131 COM20/109	5269	-1473	213 SEG9/120	3354	1849	295 SEG91/38	-1611	1849	377 COM81/48	-5269	271
50 DB1	-1083	-1895	132 COM21/108	5269	-1413	214 SEG10/119	3294	1849	296 SEG92/37	-1671	1849	378 COM80/49	-5269	210
51 DB1	-1022	-1895	133 COM22/107	5269	-1353	215 SEG11/118	3234	1849	297 SEG93/36	-1731	1849	379 COM79/50	-5269	150
52 DB0	-899	-1895	134 COM23/106	5269	-1293	216 SEG12/117	3174	1849	298 SEG94/35	-1791	1849	380 COM78/51	-5269	90
53 DB0	-838	-1895	135 COM24/105	5269	-1232	217 SEG13/116	3114	1849	299 SEG95/34	-1851	1849	381 COM77/52	-5269	30
54 GNDUM3	-775	-1895	136 COM25/104	5269	-1172	218 SEG14/115	3054	1849	300 SEG96/33	-1912	1849	382 COM76/53	-5269	-30
55 RESET*	-715	-1895	137 COM26/103	5269	-1112	219 SEG15/114	2994	1849	301 SEG97/32	-1972	1849	383 COM75/54	-5269	-90
56 RESET*	-654	-1895	138 COM27/102	5269	-1052	220 SEG16/113	2934	1849	302 SEG98/31	-2032	1849	384 COM74/55	-5269	-150
57 CS*	-531	-1895	139 COM28/101	5269	-992	221 SEG17/112	2873	1849	303 SEG99/30	-2092	1849	385 COM73/56	-5269	-210
58 CS*	-471	-1895	140 COM29/100	5269	-932	222 SEG18/111	2813	1849	304 SEG100/29	-2152	1849	386 COM72/57	-5269	-271
59 RS	-347	-1895	141 COM30/99	5269	-872	223 SEG19/110	2753	1849	305 SEG101/28	-2212	1849	387 COM71/58	-5269	-331
60 RS	-287	-1895	142 COM31/98	5269	-812	224 SEG20/109	2693	1849	306 SEG102/27	-2272	1849	388 COM70/59	-5269	-391
61 EWR*	-163	-1895	143 COM32/97	5269	-752	225 SEG21/108	2633	1849	307 SEG103/26	-2332	1849	389 COM69/60	-5269	-451
62 EWR*	-103	-1895	144 COM33/96	5269	-691	226 SEG22/107	2573	1849	308 SEG104/25	-2392	1849	390 COM68/61	-5269	-511
63 RW/RD*	21	-1895	145 COM34/95	5269	-631	227 SEG23/106	2513	1849	309 SEG105/24	-2452	1849	391 COM67/62	-5269	-571
64 RW/RD*	81	-1895	146 COM35/94	5269	-571	228 SEG24/105	2453	1849	310 SEG106/23	-2513	1849	392 COM66/63	-5269	-631
65 GND	151	-1895	147 COM36/93	5269	-511	229 SEG25/104	2393	1849	311 SEG107/22	-2573	1849	393 COM65/64	-5269	-691
66 GND	211	-1895	148 COM37/92	5269	-451	230 SEG26/103	2332	1849	312 SEG108/21	-2633	1849	394 COM64/65	-5269	-752
67 GND	271	-1895	149 COM38/91	5269	-391	231 SEG27/102	2272	1849	313 SEG109/20	-2693	1849	395 COM63/66	-5269	-812
68 GND	332	-1895	150 COM39/90	5269	-331	232 SEG28/101	2212	1849	314 SEG110/19	-2753	1849	396 COM62/67	-5269	-872
69 GND	392	-1895	151 COM40/89	5269	-271	233 SEG29/100	2152	1849	315 SEG111/18	-2813	1849	397 COM61/68	-5269	-932
70 GND	452	-1895	152 COM41/88	5269	-210	234 SEG30/99	2092	1849	316 SEG112/17	-2873	1849	398 COM60/69	-5269	-992
71 GND	512	-1895	153 COM42/87	5269	-150	235 SEG31/98	2032	1849	317 SEG113/16	-2934	1849	399 COM59/70	-5269	-1052
72 GND	572	-1895	154 COM43/86	5269	-90	236 SEG32/97	1972	1849	318 SEG114/15	-2994	1849	400 COM58/71	-5269	-1112
73 GND	632	-1895	155 COM44/85	5269	-30	237 SEG33/96	1912	1849	319 SEG115/14	-3054	1849	401 COM57/72	-5269	-1172
74 OSC2	702	-1895	156 COM45/84	5269	30	238 SEG34/95	1851	1849	320 SEG116/13	-3114	1849	402 COM56/73	-5269	-1232
75 OSC2	762	-1895	157 COM46/83	5269	90	239 SEG35/94	1791	1849	321 SEG117/12	-3174	1849	403 COM55/74	-5269	-1293
76 OSC1	886	-1895	158 COM47/82	5269	150	240 SEG36/93	1731	1849	322 SEG118/11	-3234	1849	404 COM54/75	-5269	-1353
77 OSC1	946	-1895	159 COM48/81	5269	210	241 SEG37/92	1671	1849	323 SEG119/10	-3294	1849	405 COM53/76	-5269	-1413
78 Vcc	1119	-1849	160 COM49/80	5269	271	242 SEG38/91	1611	1849	324 SEG120/9	-3354	1849			

HD66750/1

HD66751 Pad Coordinate

PAD NAME	X	Y	PAD NAME	X	Y	PAD NAME	X	Y	PAD NAME	X	Y	PAD NAME	X	Y
1 Dummy1	-5269	-1895	83 C6+	1582	-1849	165 COM38/91	5269	571	247 COM107/22	1310	1849	329 SEG61/68	-3655	1849
2 Dummy2	-5089	-1895	84 C6-	1703	-1849	166 COM39/90	5269	631	248 COM108/21	1250	1849	330 SEG62/67	-3715	1849
3 Dummy3	-5029	-1895	85 C6-	1763	-1849	167 COM40/89	5269	691	249 COM109/20	1190	1849	331 SEG63/66	-3775	1849
4 Dummy4	-4969	-1895	86 C5+	1883	-1849	168 COM41/88	5269	752	250 COM110/19	1130	1849	332 SEG64/65	-3835	1849
5 Dummy5	-4909	-1895	87 C5+	1943	-1849	169 COM42/87	5269	812	251 COM111/18	1070	1849	333 SEG65/64	-3931	1849
6 Dummy6	-4848	-1895	88 C5-	2063	-1849	170 COM43/86	5269	872	252 COM112/17	1010	1849	334 SEG66/63	-3991	1849
7 Dummy7	-4788	-1895	89 C5-	2124	-1849	171 COM44/85	5269	932	253 COM113/16	950	1849	335 SEG67/62	-4051	1849
8 Dummy8	-4728	-1895	90 C4+	2244	-1849	172 COM45/84	5269	992	254 COM114/15	890	1849	336 SEG68/61	-4111	1849
9 Dummy9	-4668	-1895	91 C4+	2304	-1849	173 COM46/83	5269	1052	255 COM115/14	829	1849	337 SEG69/60	-4171	1849
10 Dummy10	-4608	-1895	92 C4-	2424	-1849	174 COM47/82	5269	1112	256 COM116/13	769	1849	338 SEG70/59	-4232	1849
11 GNDDUM1	-4454	-1895	93 C4-	2484	-1849	175 COM48/81	5269	1172	257 COM117/12	709	1849	339 SEG71/58	-4292	1849
12 IM1	-4394	-1895	94 C3+	2605	-1849	176 COM49/80	5269	1232	258 COM118/11	649	1849	340 SEG72/57	-4352	1849
13 IM1	-4334	-1895	95 C3+	2665	-1849	177 COM50/79	5269	1292	259 COM119/10	589	1849	341 Dummy36	-4428	1895
14 IM0	-4210	-1895	96 C3-	2785	-1849	178 COM51/78	5269	1353	260 COM120/9	529	1849	342 Dummy37	-4488	1895
15 IM0	-4150	-1895	97 C3-	2845	-1849	179 COM52/77	5269	1413	261 COM121/8	469	1849	343 Dummy38	-4548	1895
16 VccDUM1	-4086	-1895	98 C2+	2965	-1849	180 COM53/76	5269	1473	262 COM122/7	409	1849	344 Dummy39	-4608	1895
17 OPOFF	-4026	-1895	99 C2+	3025	-1849	181 COM54/75	5269	1533	263 COM123/6	348	1849	345 Dummy40	-4668	1895
18 OPOFF	-3966	-1895	100 C2-	3146	-1849	182 COM55/74	5269	1593	264 COM124/5	288	1849	346 Dummy41	-4728	1895
19 TEST	-3842	-1895	101 C2-	3206	-1849	183 COM56/73	5269	1653	265 COM125/4	228	1849	347 Dummy42	-4788	1895
20 TEST	-3782	-1895	102 C1+	3326	-1849	184 Dummy23	5269	1653	266 COM126/3	168	1849	348 Dummy43	-4848	1895
21 GNDDUM2	-3722	-1895	103 C1+	3386	-1849	185 Dummy24	5089	1895	267 COM127/2	108	1849	349 Dummy44	-4909	1895
22 DB15	-3658	-1895	104 C1-	3506	-1849	186 Dummy25	5029	1895	268 COM128/1	48	1849	350 Dummy45	-4969	1895
23 DB15	-3598	-1895	105 C1-	3566	-1849	187 Dummy26	4969	1895	269 SEG1/128	-48	1849	351 Dummy46	-5029	1895
24 DB14	-3474	-1895	106 VLOUT	3687	-1849	188 Dummy27	4909	1895	270 SEG2/127	-108	1849	352 Dummy47	-5089	1895
25 DB14	-3414	-1895	107 VLOUT	3747	-1849	189 Dummy28	4848	1895	271 SEG3/126	-168	1849	353 Dummy48	-5269	1895
26 DB13	-3290	-1895	108 VLCD	3867	-1849	190 Dummy29	4788	1895	272 SEG4/125	-228	1849	354 SEG73/56	-5269	1653
27 DB13	-3230	-1895	109 VLCD	3927	-1849	191 Dummy30	4728	1895	273 SEG5/124	-288	1849	355 SEG74/55	-5269	1593
28 DB12	-3106	-1895	110 V1OUT	4047	-1849	192 Dummy31	4668	1895	274 SEG6/123	-348	1849	356 SEG75/54	-5269	1533
29 DB12	-3046	-1895	111 V2OUT	4108	-1849	193 Dummy32	4608	1895	275 SEG7/122	-409	1849	357 SEG76/53	-5269	1473
30 DB11	-2922	-1895	112 V3OUT	4168	-1849	194 Dummy33	4548	1895	276 SEG8/121	-469	1849	358 SEG77/52	-5269	1413
31 DB11	-2862	-1895	113 V4OUT	4228	-1849	195 Dummy34	4488	1895	277 SEG9/120	-529	1849	359 SEG78/51	-5269	1353
32 DB10	-2738	-1895	114 V5OUT	4288	-1849	196 Dummy35	4428	1895	278 SEG10/119	-589	1849	360 SEG79/50	-5269	1293
33 DB10	-2678	-1895	115 VTEST	4348	-1849	197 COM57/72	4352	1849	279 SEG11/118	-649	1849	361 SEG80/49	-5269	1232
34 DB9	-2554	-1895	116 Dummy11	4488	-1895	198 COM58/71	4292	1849	280 SEG12/117	-709	1849	362 SEG81/48	-5269	1172
35 DB9	-2494	-1895	117 Dummy12	4548	-1895	199 COM59/70	4232	1849	281 SEG13/116	-769	1849	363 SEG82/47	-5269	1112
36 DB8	-2370	-1895	118 Dummy13	4608	-1895	200 COM60/69	4171	1849	282 SEG14/115	-829	1849	364 SEG83/46	-5269	1052
37 DB8	-2310	-1895	119 Dummy14	4668	-1895	201 COM61/68	4111	1849	283 SEG15/114	-889	1849	365 SEG84/45	-5269	992
38 DB7	-2186	-1895	120 Dummy15	4728	-1895	202 COM62/67	4051	1849	284 SEG16/113	-950	1849	366 SEG85/44	-5269	932
39 DB7	-2126	-1895	121 Dummy16	4788	-1895	203 COM63/66	3991	1849	285 SEG17/112	-1010	1849	367 SEG86/43	-5269	872
40 DB6	-2002	-1895	122 Dummy17	4848	-1895	204 COM64/65	3931	1849	286 SEG18/111	-1070	1849	368 SEG87/42	-5269	812
41 DB6	-1942	-1895	123 Dummy18	4909	-1895	205 COM65/64	3871	1849	287 SEG19/110	-1130	1849	369 SEG88/41	-5269	752
42 DB5	-1818	-1895	124 Dummy19	4969	-1895	206 COM66/63	3775	1849	288 SEG20/109	-1190	1849	370 SEG89/40	-5269	691
43 DB5	-1758	-1895	125 Dummy20	5029	-1895	207 COM67/62	3715	1849	289 SEG21/108	-1250	1849	371 SEG90/39	-5269	631
44 DB4	-1634	-1895	126 Dummy21	5089	-1895	208 COM68/61	3655	1849	290 SEG22/107	-1310	1849	372 SEG91/38	-5269	571
45 DB4	-1574	-1895	127 Dummy22	5269	-1895	209 COM69/60	3595	1849	291 SEG23/106	-1370	1849	373 SEG92/37	-5269	511
46 DB3	-1450	-1895	128 COM1/128	5269	-1653	210 COM70/59	3535	1849	292 SEG24/105	-1431	1849	374 SEG93/36	-5269	451
47 DB3	-1390	-1895	129 COM2/127	5269	-1593	211 COM71/58	3475	1849	293 SEG25/104	-1491	1849	375 SEG94/35	-5269	391
48 DB2	-1266	-1895	130 COM3/126	5269	-1533	212 COM72/57	3415	1849	294 SEG26/103	-1551	1849	376 SEG95/34	-5269	331
49 DB2	-1206	-1895	131 COM4/125	5269	-1473	213 COM73/56	3354	1849	295 SEG27/102	-1611	1849	377 SEG96/33	-5269	271
50 DB1	-1083	-1895	132 COM5/124	5269	-1413	214 COM74/55	3294	1849	296 SEG28/101	-1671	1849	378 SEG97/32	-5269	210
51 DB1	-1022	-1895	133 COM6/123	5269	-1353	215 COM75/54	3234	1849	297 SEG29/100	-1731	1849	379 SEG98/31	-5269	150
52 DB0	-899	-1895	134 COM7/122	5269	-1293	216 COM76/53	3174	1849	298 SEG30/99	-1791	1849	380 SEG99/30	-5269	90
53 DB0	-838	-1895	135 COM8/121	5269	-1232	217 COM77/52	3114	1849	299 SEG31/98	-1851	1849	381 SEG100/29	-5269	30
54 GNDDUM3	-775	-1895	136 COM9/120	5269	-1172	218 COM78/51	3054	1849	300 SEG32/97	-1912	1849	382 SEG101/28	-5269	-30
55 RESET*	-715	-1895	137 COM10/119	5269	-1112	219 COM79/50	2994	1849	301 SEG33/96	-1972	1849	383 SEG102/27	-5269	-90
56 RESET*	-654	-1895	138 COM11/118	5269	-1052	220 COM80/49	2934	1849	302 SEG34/95	-2032	1849	384 SEG103/26	-5269	-150
57 CS*	-531	-1895	139 COM12/117	5269	-992	221 COM81/48	2873	1849	303 SEG35/94	-2092	1849	385 SEG104/25	-5269	-210
58 CS*	-471	-1895	140 COM13/116	5269	-932	222 COM82/47	2813	1849	304 SEG36/93	-2152	1849	386 SEG105/24	-5269	-271
59 RS	-347	-1895	141 COM14/115	5269	-872	223 COM83/46	2753	1849	305 SEG37/92	-2212	1849	387 SEG106/23	-5269	-331
60 RS	-287	-1895	142 COM15/114	5269	-812	224 COM84/45	2693	1849	306 SEG38/91	-2272	1849	388 SEG107/22	-5269	-391
61 EWR*	-163	-1895	143 COM16/113	5269	-752	225 COM85/44	2633	1849	307 SEG39/90	-2332	1849	389 SEG108/21	-5269	-451
62 EWR*	-103	-1895	144 COM17/112	5269	-691	226 COM86/43	2573	1849	308 SEG40/89	-2392	1849	390 SEG109/20	-5269	-511
63 RW/RD*	21	-1895	145 COM18/111	5269	-631	227 COM87/42	2513	1849	309 SEG41/88	-2452	1849	391 SEG110/19	-5269	-571
64 RW/RD*	81	-1895	146 COM19/110	5269	-571	228 COM88/41	2453	1849	310 SEG42/87	-2512	1849	392 SEG111/18	-5269	-631
65 GND	151	-1895	147 COM20/109	5269	-511	229 COM89/40	2392	1849	311 SEG43/86	-2572	1849	393 SEG112/17	-5269	-691
66 GND	211	-1895	148 COM21/108	5269	-451	230 COM90/39	2332	1849	312 SEG44/85	-2632	1849	394 SEG113/16	-5269	-752
67 GND	271	-1895	149 COM22/107	5269	-391	231 COM91/38	2272	1849	313 SEG45/84	-2692	1849	395 SEG114/15	-5269	-812
68 GND	332	-1895	150 COM23/106	5269	-331	232 COM92/37	2212	1849	314 SEG46/83	-2752	1849	396 SEG115/14	-5269	-872
69 GND	392	-1895	151 COM24/105	5269	-271	233 COM93/36	2152	1849	315 SEG47/82	-2812	1849	397 SEG116/13	-5269	-932
70 GND	452	-1895	152 COM25/104	5269	-210	234 COM94/35	2092	1849	316 SEG48/81	-2872	1849	398 SEG117/12	-5269	-992
71 GND	512	-1895	153 COM26/103	5269	-150	235 COM95/34	2032	1849	317 SEG49/80	-2932	1849	399 SEG118/11	-5269	-1052
72 GND	572	-1895	154 COM27/102	5269	-90	236 COM96/33	1972	1849	318 SEG50/79	-2992	1849	400 SEG119/10	-5269	-1112
73 GND	632	-1895	155 COM28/101	5269	-30	237 COM97/32	1912	1849	319 SEG51/78	-3052	1849	401 SEG120/9	-5269	-1172
74 OSC2	702	-1895	156 COM29/100	5269	30	238 COM98/31	1851	1849	320 SEG52/77	-3112	1849	402 SEG121/8	-5269	-1232
75 OSC2	762	-1895	157 COM30/99	5269	90	239 COM99/30	1791	1849	321 SEG53/76	-3172	1849	403 SEG122/7	-5269	-1292
76 OSC1	886	-1895	158 COM31/98	5269	150	240 COM100/29	1731	1849	322 SEG54/75	-3232	1849	404 SEG123/6	-5269	-1352
77 OSC1	946	-1895	159 COM32/97	5269	210	241 COM101/28	1671	1849	323 SEG55/74	-3292	1849	405 SEG124/5	-5269	-1412
78 Vcc	1119	-1849	160 COM33/96	5269	271	242 COM102/27	1611	1849	324 SEG56/73	-3352	1			

TCP Dimensions (HD66750TB0)

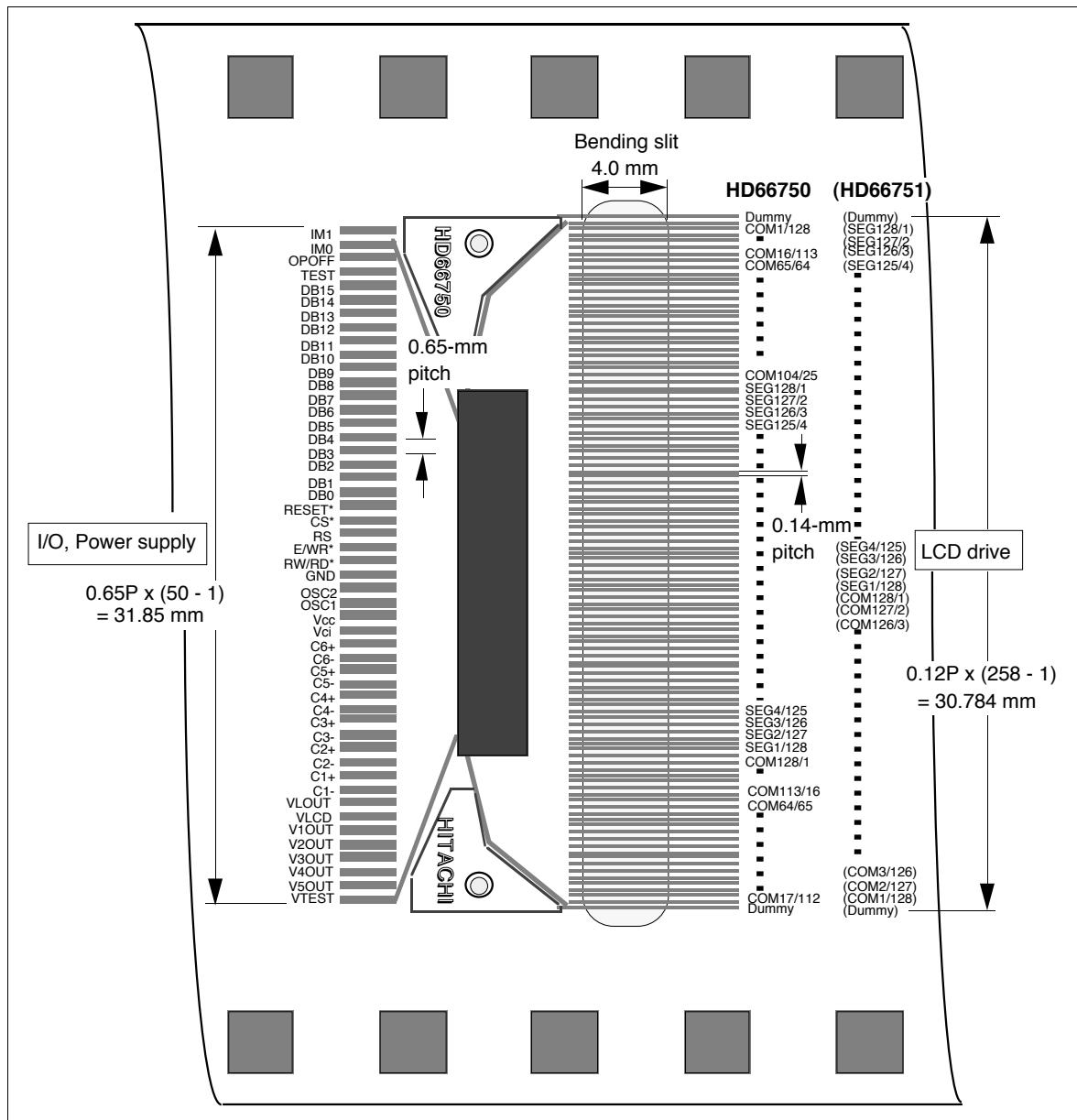

HD66750/1

Pin Functions

Table 2 Pin Functional Description

Signals	Number of Pins	I/O	Connected to	Functions		
IM1, IM0	2	I	GND or V _{CC}	Selects the MPU interface mode:		
				IM1	IM0	MPU interface mode
				GND	GND	68-system 16-bit bus interface
				GND	V _{CC}	68-system 8-bit bus interface
				V _{CC}	GND	80-system 16-bit bus interface
				V _{CC}	V _{CC}	80-system 8-bit bus interface
CS*	1	I	MPU	Selects the HD66750/1: Low: HD66750/1 is selected and can be accessed High: HD66750/1 is not selected and cannot be accessed Must be fixed at GND level when not in use.		
RS	1	I	MPU	Selects the register. Low: Index/status High: Control		
E/WR*	1	I	MPU	For a 68-system bus interface, serves as an enable signal to activate data read/write operation. For an 80-system bus interface, serves as a write strobe signal and writes data at the low level.		
RW/RD*	1	I	MPU	For a 68-system bus interface, serves as a signal to select data read/write operation. Low: Write High: Read For an 80-system bus interface, serves as a read strobe signal and reads data at the low level.		
DB0–DB15	16	I/O	MPU	Serves as a 16-bit bidirectional data bus. For an 8-bit bus interface, data transfer uses DB15–DB8; fix unused DB7–DB0 to the V _{CC} or GND level.		
COM1/128– COM128/1	128	O	LCD	Output signals for common drive: All the unused pins output unselected waveforms. In the display-off period (D = 0), sleep mode (SLP = 1), or standby mode (STB = 1), all pins output GND level. The CMS bit can change the shift direction of the common signal. For example, if CMS = 0, COM1/128 is COM1, and COM128/1 is COM128. If CMS = 1, COM1/128 is COM128, and COM128/1 is COM1. Note that the start position of the common output is shifted by CN1–CN0 bits.		
SEG1/128– SEG128/1	128	O	LCD	Output signals for segment drive. In the display-off period (D = 0), sleep mode (SLP = 1), or standby mode (STB = 1), all pins output GND level. The SGS bit can change the shift direction of the segment signal. For example, if SGS = 0, SEG1/128 is SEG1. If SGS = 1, SEG1/128 is SEG128.		

Table 2 Pin Functional Description (cont)

Signals	Number of Pins	I/O	Connected	Functions
V1OUT– V5OUT	5	I or O	Open or external bleeder-resistor	Used for output from the internal operational amplifiers when they are used (OPOFF = GND); attach a capacitor to stabilize the output. When the amplifiers are not used (OPOFF = V _{CC}), V1 to V5 voltages can be supplied to these pins externally.
V _{LCD}	1	—	Power supply	Power supply for LCD drive. V _{LCD} – GND = 17 V max.
V _{CC} , GND	2	—	Power supply	V _{CC} : +1.8 V to +5.5 V; GND (logic): 0 V
OSC1, OSC2	2	I or O	Oscillation-resistor or clock	For R-C oscillation using an external resistor, connect an external resistor. For external clock supply, input clock pulses to OSC1.
Vci	1	I	Power supply	Inputs a reference voltage and supplies power to the booster; generates the liquid crystal display drive voltage from the operating voltage. The boosting output voltage must not be larger than the absolute maximum ratings. Must be left disconnected when the booster is not used.
VLOUT	1	O	V _{LCD} pin/booster capacitance	Potential difference between Vci and GND is two- to seven-times-boosted and then output. Magnitude of boost is selected by instruction.
C1+, C1–	2	—	Booster capacitance	External capacitance should be connected here for boosting.
C2+, C2–	2	—	Booster capacitance	External capacitance should be connected here for boosting.
C3+, C3–	2	—	Booster capacitance	External capacitance should be connected here for boosting.
C4+, C4–	2	—	Booster capacitance	External capacitance should be connected here for boosting.
C5+, C5–	2	—	Booster capacitance	External capacitance should be connected here for boosting.
C6+, C6–	2	—	Booster capacitance	External capacitance should be connected here for boosting.
RESET*	1	I	MPU or external R-C circuit	Reset pin. Initializes the LSI when low. Must be reset after power-on.
OPOFF	1	I	V _{CC} or GND	Turns the internal operational amplifier off when OPOFF = V _{CC} , and turns it on when OPOFF = GND. If the amplifier is turned off (OPOFF = V _{CC}), V1 to V5 must be supplied to the V1OUT to V5OUT pins.
VccDUM	2	O	Input pins	Outputs the internal V _{CC} level; shorting this pin sets the adjacent input pin to the V _{CC} level.
GNDDUM	4	O	Input pins	Outputs the internal GND level; shorting this pin sets the adjacent input pin to the GND level.
Dummy	4	—	—	Dummy pad. Must be left disconnected.
TEST	1	I	GND	Test pin. Must be fixed at GND level.
VTEST	1	—	—	Test pin. Must be left disconnected.

HD66750/1

Block Function Description

System Interface

The HD66750/1 has four high-speed system interfaces: an 80-system 16-bit/8-bit bus and a 68-system 16-bit/8-bit bus. The interface mode is selected by the IM1-0 pins.

The HD66750/1 has three 16-bit registers: an index register (IR), a write data register (WDR), and a read data register (RDR). The IR stores index information from the control registers and the CGRAM. The WDR temporarily stores data to be written into control registers and the CGRAM, and the RDR temporarily stores data read from the CGRAM. Data written into the CGRAM from the MPU is first written into the WDR and then is automatically written into the CGRAM by internal operation. Data is read through the RDR when reading from the CGRAM, and the first read data is invalid and the second and the following data are normal. When a logic operation is performed inside of the HD66750/1 by using the display data set in the CGRAM and the data written from the MPU, the data read through the RDR is used. Accordingly, the MPU does not need to read data twice nor to fetch the read data into the MPU. This enables high-speed processing.

Execution time for instruction excluding oscillation start is 0 clock cycle and instructions can be written in succession.

Table 3 Register Selection by RS and R/W Bits

R/W Bits	RS Bits	Operations
0	0	Writes indexes into IR
1	0	Disabled
0	1	Writes into control registers and CGRAM through WDR
1	1	Reads from CGRAM through RDR

Bit Operation

The HD66750/1 supports the following functions: a bit rotation function that writes the data written from the MPU into the CGRAM by moving the display position in bit units, a write data mask function that selects and writes data into the CGRAM in bit units, and a logic operation function that performs logic operations on the display data set in the CGRAM and writes into the CGRAM. With the 16-bit bus interface, these functions can greatly reduce the processing loads of the MPU graphics software and can rewrite the display data in the CGRAM at high speed. For details, see the Graphics Operation Function section.

Address Counter (AC)

The address counter (AC) assigns addresses to the CGRAM. When an address set instruction is written into the IR, the address information is sent from the IR to the AC.

After writing into the CGRAM, the AC is automatically incremented by 1 (or decremented by 1). After reading from the data, the RDM bit automatically updates or does not update the AC.

Graphic RAM (CGRAM)

The graphic RAM (CGRAM) stores bit-pattern data of 128 x 120 dots. It has two bits/pixel and 4096-byte capacity.

Grayscale Control Circuit

The grayscale control circuit performs four-grayscale control with the frame rate control (FRC) method for four-monochrome grayscale display. For details, see the Four Grayscale Display Function section.

Timing Generator

The timing generator generates timing signals for the operation of internal circuits such as the CGRAM. The RAM read timing for display and internal operation timing by MPU access are generated separately to avoid interference with one another.

Oscillation Circuit (OSC)

The HD66750/1 can provide R-C oscillation simply through the addition of an external oscillation-resistor between the OSC1 and OSC2 pins. The appropriate oscillation frequency for operating voltage, display size, and frame frequency can be obtained by adjusting the external-resistor value. Clock pulses can also be supplied externally. Since R-C oscillation stops during the standby mode, current consumption can be reduced. For details, see the Oscillation Circuit section.

Liquid Crystal Display Driver Circuit

The liquid crystal display driver circuit consists of 128 common signal drivers (COM1 to COM128) and 128 segment signal drivers (SEG1 to SEG128). When the number of lines are selected by a program, the required common signal drivers automatically output drive waveforms, while the other common signal drivers continue to output unselected waveforms.

Display pattern data is latched when 128-bit data has arrived. The latched data then enables the segment signal drivers to generate drive waveform outputs. The shift direction of 128-bit data can be changed by the SGS bit. The shift direction for the common driver can also be changed by the CMS bit by selecting an appropriate direction for the device mounting configuration.

When multiplexing drive is not used, or during the standby or sleep mode, all the above common and segment signal drivers output the GND level, halting the display.

Booster (DC-DC Converter)

The booster generates two-, five-, six-, or seven-times voltage input to the Vci pin. With this, both the internal logic units and LCD drivers can be controlled with a single power supply. Boost output level from twice to seven-times boost can be selected by software. For details, see the Power Supply for Liquid Crystal Display Drive section.

HD66750/1

V-Pin Voltage Follower

A voltage follower for each voltage level (V1 to V5) reduces current consumption by the LCD drive power supply circuit. No external resistors are required because of the internal bleeder-resistor, which generates different levels of LCD drive voltage. This internal bleeder-resistor can be software-specified from 1/4 bias to 1/11 bias, according to the liquid crystal display drive duty value. The voltage followers can be turned off while multiplexing drive is not being used. For details, see the Power Supply for Liquid Crystal Display Drive section.

Contrast Adjuster

The contrast adjuster can be used to adjust LCD contrast in 64 steps by varying the LCD drive voltage by software. This can be used to select an appropriate LCD brightness or to compensate for temperature.

CGRAM Address Map

Table 4 Relationship between Display Position and CGRAM Address

Segment Driver		SEG1/128	SEG2/127	SEG3/126	SEG4/125	SEG5/124	SEG6/123	SEG7/122	SEG8/121	SEG9/120	...	SEG16/113	SEG17/112	...	SEG24/105	SEG121/8	...	SEG128/1											
Bit	SGS="0"	D0	D1	D2	D3	D4	D5	D6	D7	D8	D9	D10	D11	D12	D13	D14	D15	D0	D1	...	D15	D0	D1	...	D15	D0	D1	...	D15
	SGS="1"	D15	D14	D13	D12	D11	D10	D9	D8	D7	D6	D5	D4	D3	D2	D1	D0	D15	D14	...	D0	D15	D14	...	D0	D15	D14	...	D0
COM1	Address: "000"H															"001"H	"002"H	"00F"H											
COM2	Address: "010"H															"011"H	"012"H	"01F"H											
COM3	Address: "020"H															"021"H	"022"H	"02F"H											
COM4	Address: "030"H															"031"H	"032"H	"03F"H											
COM5	Address: "040"H															"041"H	"042"H	"04F"H											
COM6	Address: "050"H															"051"H	"052"H	"05F"H											
COM7	Address: "060"H															"061"H	"062"H	"06F"H											
COM8	Address: "070"H															"071"H	"072"H	"07F"H											
COM9	Address: "080"H															"081"H	"082"H	"08F"H											
COM10	Address: "090"H															"091"H	"092"H	"09F"H											
COM11	Address: "0A0"H															"0A1"H	"0A2"H	"0AF"H											
COM12	Address: "0B0"H															"0B1"H	"0B2"H	"0BF"H											
COM13	Address: "0C0"H															"0C1"H	"0C2"H	"0CF"H											
COM14	Address: "0D0"H															"0D1"H	"0D2"H	"0DF"H											
COM15	Address: "0E0"H															"0E1"H	"0E2"H	"0EF"H											
COM16	Address: "0F0"H															"0F1"H	"0F2"H	"0FF"H											
COM17	Address: "100"H															"101"H	"102"H	"10F"H											
COM18	Address: "110"H															"111"H	"112"H	"11F"H											
COM19	Address: "120"H															"121"H	"122"H	"12F"H											
COM20	Address: "130"H															"131"H	"132"H	"13F"H											
.																										
.																										
COM125	Address: "7C0"H															"7C1"H	"7C2"H	"7CF"H											
COM126	Address: "7D0"H															"7D1"H	"7D2"H	"7DF"H											
COM127	Address: "7E0"H															"7E1"H	"7E2"H	"7EF"H											
COM128	Address: "7F0"H															"7F1"H	"7F2"H	"7FF"H											

Table 5 Relationship between CGRAM Data and Display Contents

Upper Bit	Lower Bit	LCD
0	0	Non-selection display (unlit)
0	1	1/3- or 1/2-level grayscale display (selected by the GS bit)
1	0	2/3-level grayscale display
1	1	Selection display (lit)

Note: Upper bits: DB15, DB13, DB11, DB9, DB7, DB5, DB3, DB1
 Lower bits: DB14, DB12, DB10, DB8, DB6, DB4, DB2, DB0

HD66750/1

Instructions

Outline

The HD66750/1 uses the 16-bit bus architecture. Before the internal operation of the HD66750/1 starts, control information is temporarily stored in the registers described below to allow high-speed interfacing with a high-performance microcomputer. The internal operation of the HD66750/1 is determined by signals sent from the microcomputer. These signals, which include the register selection signal (RS), the read/write signal (R/W), and the data bus signals (DB15 to DB7), make up the HD66750/1 instructions. There are seven categories of instructions that:

- Specify the index
- Read the status
- Control the display
- Control power management
- Process the graphics data
- Set internal CGRAM addresses
- Transfer data to and from the internal CGRAM

Normally, instructions that write data are used the most. However, an auto-update of internal CGRAM addresses after each data write can lighten the microcomputer program load.

Because instructions are executed in 0 cycles, they can be written in succession.

Instruction Descriptions

Index

The index instruction specifies the RAM control indexes (R00 to R12). It sets the register number in the range of 00000 to 10010 in binary form.

R/W	RS	DB15	DB14	DB13	DB12	DB11	DB10	DB9	DB8	DB7	DB6	DB5	DB4	DB3	DB2	DB1	DB0
0	0	*	*	*	*	*	*	*	*	*	*	*	ID4	ID3	ID2	ID1	ID0

Figure 1 Index Instruction

Status Read

The status read instruction reads the internal status of the HD66750/1.

L6–0: Indicate the driving raster-row position where the liquid crystal display is being driven.

C5–0: Read the contrast setting values (CT5–0).

R/W	RS	DB15	DB14	DB13	DB12	DB11	DB10	DB9	DB8	DB7	DB6	DB5	DB4	DB3	DB2	DB1	DB0
1	0	0	L6	L5	L4	L3	L2	L1	L0	0	0	C5	C4	C3	C2	C1	C0

Figure 2 Status Read Instruction

Start Oscillation

The start oscillation instruction restarts the oscillator from the halt state in the standby mode. After issuing this instruction, wait at least 10 ms for oscillation to stabilize before issuing the next instruction. (See the Standby Mode section.)

If this register is read forcibly when R/W = 1, 0750H is read.

R/W	RS	DB15	DB14	DB13	DB12	DB11	DB10	DB9	DB8	DB7	DB6	DB5	DB4	DB3	DB2	DB1	DB0
0	1	*	*	*	*	*	*	*	*	*	*	*	*	*	*	*	1
1	1	0	0	0	0	0	1	1	1	0	1	0	1	0	0	0	0

Figure 3 Start Oscillation Instruction

HD66750/1

Driver Output Control

CMS: Selects the output shift direction of a common driver. When CMS = 0, COM1/128 shifts to COM1, and COM128/1 to COM128. When CMS = 1, COM1/128 shifts to COM128, and COM128/1 to COM1. Output position of a common driver shifts depending on the CN bit setting.

SGS: Selects the output shift direction of a segment driver. When SGS = 0, SEG1/128 shifts to SEG1, and SEG128/1 to SEG128. When SGS = 1, SEG1/128 shifts to SEG128, and SEG128/1 to SEG1.

CN: When CN = 1, the display position is shifted down by 32 raster-rows and display starts from COM33. When the liquid crystal is driven at a low duty ratio in the system wait state, it can be partially displayed at the center of the screen. For details, see the Partial-display-on Function section.

NL3-0: Specify the LCD drive duty ratio. The duty ratio can be adjusted for every eight raster-rows. CGRAM address mapping does not depend on the setting value of the drive duty ratio.

R/W	RS	DB15	DB14	DB13	DB12	DB11	DB10	DB9	DB8	DB7	DB6	DB5	DB4	DB3	DB2	DB1	DB0
0	1	*	*	*	*	*	*	CMS	SGS	*	CN	*	*	NL3	NL2	NL1	NL0

Figure 4 Driver Output Control Instruction

Table 6 NL Bits and Drive Duty

NL3	NL2	NL1	NL0	Display Size	LCD Drive Duty	Common Driver Used
0	0	0	0	128 x 8 dots	1/8 Duty	COM1–COM8
0	0	0	1	128 x 16 dots	1/16 Duty	COM1–COM16
0	0	1	0	128 x 24 dots	1/24 Duty	COM1–COM24
0	0	1	1	128 x 32 dots	1/32 Duty	COM1–COM32
0	1	0	0	128 x 40 dots	1/40 Duty	COM1–COM40
0	1	0	1	128 x 48 dots	1/48 Duty	COM1–COM48
0	1	1	0	128 x 56 dots	1/56 Duty	COM1–COM56
0	1	1	1	128 x 64 dots	1/64 Duty	COM1–COM64
1	0	0	0	128 x 72 dots	1/72 Duty	COM1–COM72
1	0	0	1	128 x 80 dots	1/80 Duty	COM1–COM80
1	0	1	0	128 x 88 dots	1/88 Duty	COM1–COM88
1	0	1	1	128 x 96 dots	1/96 Duty	COM1–COM96
1	1	0	0	128 x 104 dots	1/104 Duty	COM1–COM104
1	1	0	1	128 x 112 dots	1/112 Duty	COM1–COM112
1	1	1	0	128 x 120 dots	1/120 Duty	COM1–COM120
1	1	1	1	128 x 128 dots	1/128 Duty	COM1–COM128

LCD-Driving-Waveform Control

B/C: When B/C = 0, a B-pattern waveform is generated and alternates in every frame for LCD drive. When B/C = 1, a C-pattern waveform is generated and alternates in each raster-row specified by bits EOR and NW4–NW0 in the LCD-driving-waveform control register. For details, see the n-raster-row Reversed AC Drive section.

EOR: When the C-pattern waveform is set (B/C = 1) and EOR = 1, the odd/even frame-select signals and the n-raster-row reversed signals are EORed for alternating drive. EOR is used when the LCD is not alternated by combining the set values of the LCD drive duty ratio and the n raster-row. For details, see the n-raster-row Reversed AC Drive section.

NW4–0: Specify the number of raster-rows n that will alternate at the C-pattern waveform setting (B/C = 1). NW4–NW0 alternate for every set value + 1 raster-row, and the first to the 32nd raster-rows can be selected.

R/W	RS	DB15	DB14	DB13	DB12	DB11	DB10	DB9	DB8	DB7	DB6	DB5	DB4	DB3	DB2	DB1	DB0
0	1	*	*	*	*	*	*	*	*	*	B/C	EOR	NW4	NW3	NW2	NW1	NW0

Figure 5 LCD-Driving-Waveform Control Instruction

HD66750/1

Table 7 Common Driver Pin Function

Common Driver Pin	Common Driver Pin Function			
	CN = 0 (Normal Output)		CN = 1 (Center Output)	
	CMS = 0	CMS = 1	CMS = 0	CMS = 1
COM1/128	COM1	COM128	COM97	COM96
:	:	:	:	:
COM8/121	COM8	COM121	COM104	COM89
COM9/120	COM9	COM120	COM105	COM88
:	:	:	:	:
COM16/113	COM16	COM113	COM112	COM81
COM17/112	COM17	COM112	COM113	COM80
:	:	:	:	:
COM24/105	COM24	COM105	COM120	COM73
COM25/104	COM25	COM104	(COM121)	COM72
:	:	:	:	:
COM32/97	COM32	COM97	(COM128)	COM65
COM33/96	COM33	COM96	COM1	COM64
:	:	:	:	:
COM40/89	COM40	COM89	COM8	COM57
COM41/88	COM41	COM88	COM9	COM56
:	:	:	:	:
COM48/81	COM48	COM81	COM16	COM49
COM49/80	COM49	COM80	COM17	COM48
:	:	:	:	:
COM56/73	COM56	COM73	COM24	COM41
COM57/72	COM57	COM72	COM25	COM40
:	:	:	:	:
COM64/65	COM64	COM65	COM32	COM33
COM65/64	COM65	COM64	COM33	COM32
:	:	:	:	:
COM72/57	COM72	COM57	COM40	COM25
COM73/56	COM73	COM56	COM41	COM24
:	:	:	:	:
COM80/49	COM80	COM49	COM48	COM17
COM81/48	COM81	COM48	COM49	COM16
:	:	:	:	:
COM88/41	COM88	COM41	COM56	COM9
COM89/40	COM89	COM40	COM57	COM8
:	:	:	:	:
COM96/33	COM96	COM33	COM64	COM1

Table 7 Common Driver Pin Function (cont)

Common Driver Pin	Common Driver Pin Function			
	CN = 0 (Normal Output)		CN = 1 (Center Output)	
	CMS = 0	CMS = 1	CMS = 0	CMS = 1
COM97/32	COM97	COM32	COM65	(COM128)
:	:	:	:	:
COM104/25	COM104	COM25	COM72	(COM121)
COM105/24	COM105	COM24	COM73	COM120
:	:	:	:	:
COM112/17	COM112	COM17	COM80	COM113
COM113/16	COM113	COM16	COM81	COM112
:	:	:	:	:
COM120/9	COM120	COM9	COM88	COM105
COM121/8	COM121	COM8	COM89	COM104
:	:	:	:	:
COM128/1	COM128	COM1	COM96	COM97

Power Control

BS2-0: The LCD drive bias value is set within the range of a 1/4 to 1/11 bias. The LCD drive bias value can be selected according to its drive duty ratio and voltage. For details, see the Liquid Crystal Display Drive Bias Selector section.

BT1-0: The output factor of V5OUT between two-times, three-times, four-times, five-times, six-times, and seven-times boost is switched. The LCD drive voltage level can be selected according to its drive duty ratio and bias. Lower amplification of the booster consumes less current.

DC1-0: The operating frequency in the booster is selected. When the boosting operating frequency is high, the driving ability of the booster and the display quality become high, but the current consumption is increased. Adjust the frequency considering the display quality and the current consumption.

AP1-0: The amount of fixed current from the fixed current source in the operational amplifier for V pins (V1 to V5) is adjusted. When the amount of fixed current is large, the driving ability of the booster and the display quality become high, but the current consumption is increased. Adjust the fixed current considering the display quality and the current consumption.

During no display, when AP1-0 = 00, the current consumption can be reduced by ending the operational amplifier and booster operation.

HD66750/1

Table 8 BS Bits and LCD Drive Bias Value

BS2	BS1	BS0	LCD Drive Bias Value
0	0	0	1/11 bias drive
0	0	1	1/10 bias drive
0	1	0	1/9 bias drive
0	1	1	1/8 bias drive
1	0	0	1/7 bias drive
1	0	1	1/6 bias drive
1	1	0	1/5 bias drive
1	1	1	1/4 bias drive

Table 9 BT Bits and Output Level

BT1	BT0	V5OUT Output Level
0	0	Two-times boost
0	1	Five-times boost
1	0	Six-times boost
1	1	Seven-times boost

Table 10 DC Bits and Operating Clock Frequency

DC1	DC0	Operating Clock Frequency in the Booster
0	0	32-divided clock
0	1	16-divided clock
1	0	8-divided clock
1	1	4-divided clock

Table 11 AP Bits and Amount of Fixed Current

AP1	AP0	Amount of Fixed Current in the Operational Amplifier
0	0	Operational amplifier and booster do not operate.
0	1	Small
1	0	Middle
1	1	Large

SLP: When SLP = 1, the HD66750/1 enters the sleep mode, where the internal display operations are halted except for the R-C oscillator, thus reducing current consumption. For details, see the Sleep Mode section. Only the following instructions can be executed during the sleep mode.

Power control (BS2–0, BT1–0, DC1–0, AP1–0, SLP, and STB bits)

During the sleep mode, the other CGRAM data and instructions cannot be updated although they are

retained.

STB: When $STB = 1$, the HD66750/1 enters the standby mode, where display operation completely stops, halting all the internal operations including the internal R-C oscillator. Further, no external clock pulses are supplied. For details, see the Standby Mode section.

Only the following instructions can be executed during the standby mode.

- a. Standby mode cancel ($STB = 0$)
- b. Start oscillation
- c. Power control (BS2–0, BT1–0, DC1–0, AP1–0, SLP, and STB bits)

During the standby mode, the CGRAM data and instructions may be lost. To prevent this, they must be set again after the standby mode is canceled.

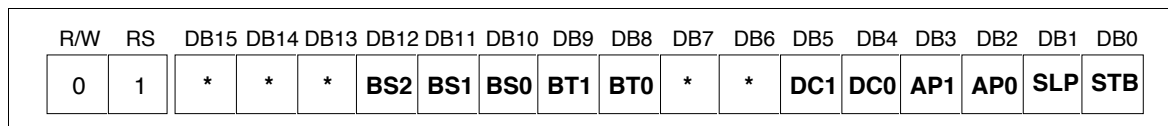

Figure 6 Power Control Instruction

HD66750/1

Contrast Control

CT5-0: These bits control the LCD drive voltage (potential difference between V1 and GND) to adjust 64-step contrast. For details, see the Contrast Adjuster section.

R/W	RS	DB15	DB14	DB13	DB12	DB11	DB10	DB9	DB8	DB7	DB6	DB5	DB4	DB3	DB2	DB1	DB0
0	1	*	*	*	*	*	*	*	*	*	*	CT5	CT4	CT3	CT2	CT1	CT0

Figure 7 Contrast Control Instruction

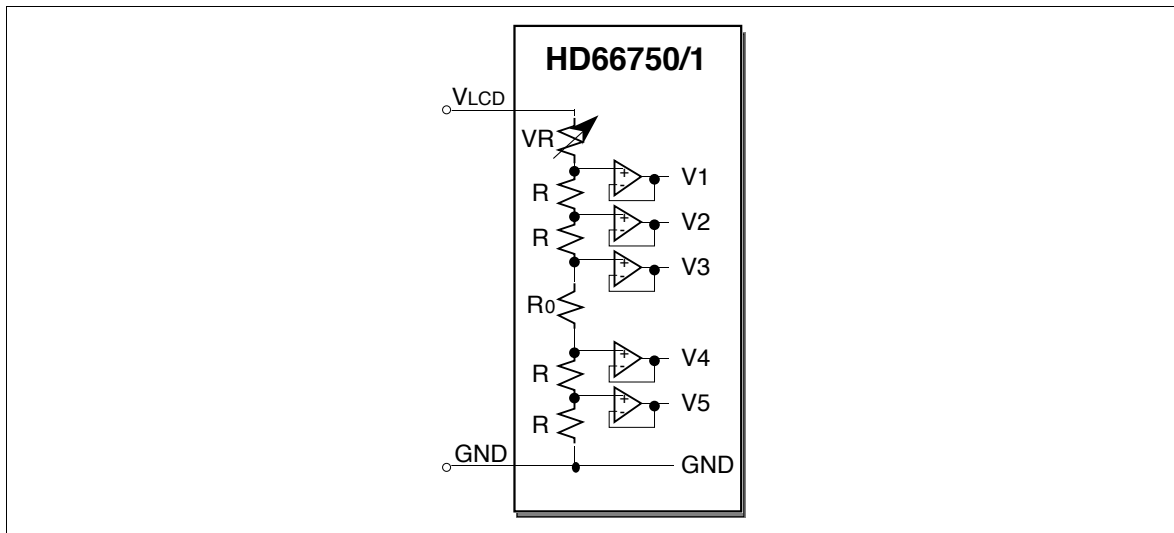

Figure 8 Contrast Adjuster

Table 12 CT Bits and Variable Resistor Value of Contrast Adjuster

CT Set Value						
CT5	CT4	CT3	CT2	CT1	CT0	Variable Resistor (VR)
0	0	0	0	0	0	3.20 x R
0	0	0	0	0	1	3.15 x R
0	0	0	0	1	0	3.10 x R
0	0	0	0	1	1	3.05 x R
0	0	0	1	0	0	3.00 x R
			.			.
			.			.
0	1	1	1	1	1	1.65 x R
1	0	0	0	0	0	1.60 x R
1	0	0	0	0	1	1.55 x R
1	0	0	0	1	0	1.50 x R
			.			.
			.			.
1	1	1	1	0	1	0.15 x R
1	1	1	1	1	0	0.10 x R
1	1	1	1	1	1	0.05 x R

Entry Mode

Rotation

The write data sent from the microcomputer is modified in the HD66750/1 and written to the CGRAM. The display data in the CGRAM can be quickly rewritten to reduce the load of the microcomputer software processing. For details, see the Graphics Operation Function section.

I/D: When I/D = 1, the address counter (AC) is automatically incremented by 1 after the data is written to the CGRAM. When I/D = 0, the AC is automatically decremented by 1 after the data is written to the CGRAM.

AM1-0: Set the automatic update method of the AC after the data is written to the CGRAM. When AM1-0 = 00, the data is continuously written in parallel. When AM1-0 = 01, the data is continuously written vertically. When AM1-0 = 10, the data is continuously written vertically with two-word width (32-bit length).

LG1-0: Write again the data read from the CGRAM and the data written from the microcomputer to the CGRAM by a logical operation. When LG1-0 = 00, replace (no logical operation) is done. ORed when LG1-0 = 01, ANDed when LG1-0 = 10, and EORed when LG1-0 = 11.

RT2-0: Write the data sent from the microcomputer to the CGRAM by rotating in a bit unit. RT3-0 specify rotation. For example, when RT2-0 = 001, the data is rotated in the upper side by two bits. When RT2-0 = 111, the data is rotated in the upper side by 14 bits. The upper bit overflowed in the most significant bit (MSB) side is rotated in the least significant bit (LSB) side.

R/W	RS	DB15	DB14	DB13	DB12	DB11	DB10	DB9	DB8	DB7	DB6	DB5	DB4	DB3	DB2	DB1	DB0
0	1	*	*	*	*	*	*	*	*	*	*	*	I/D	AM1	AM0	LG1	LG0
0	1	*	*	*	*	*	*	*	*	*	*	*	*	*	RT2	RT1	RT0

Figure 9 Entry Mode and Rotation Instructions

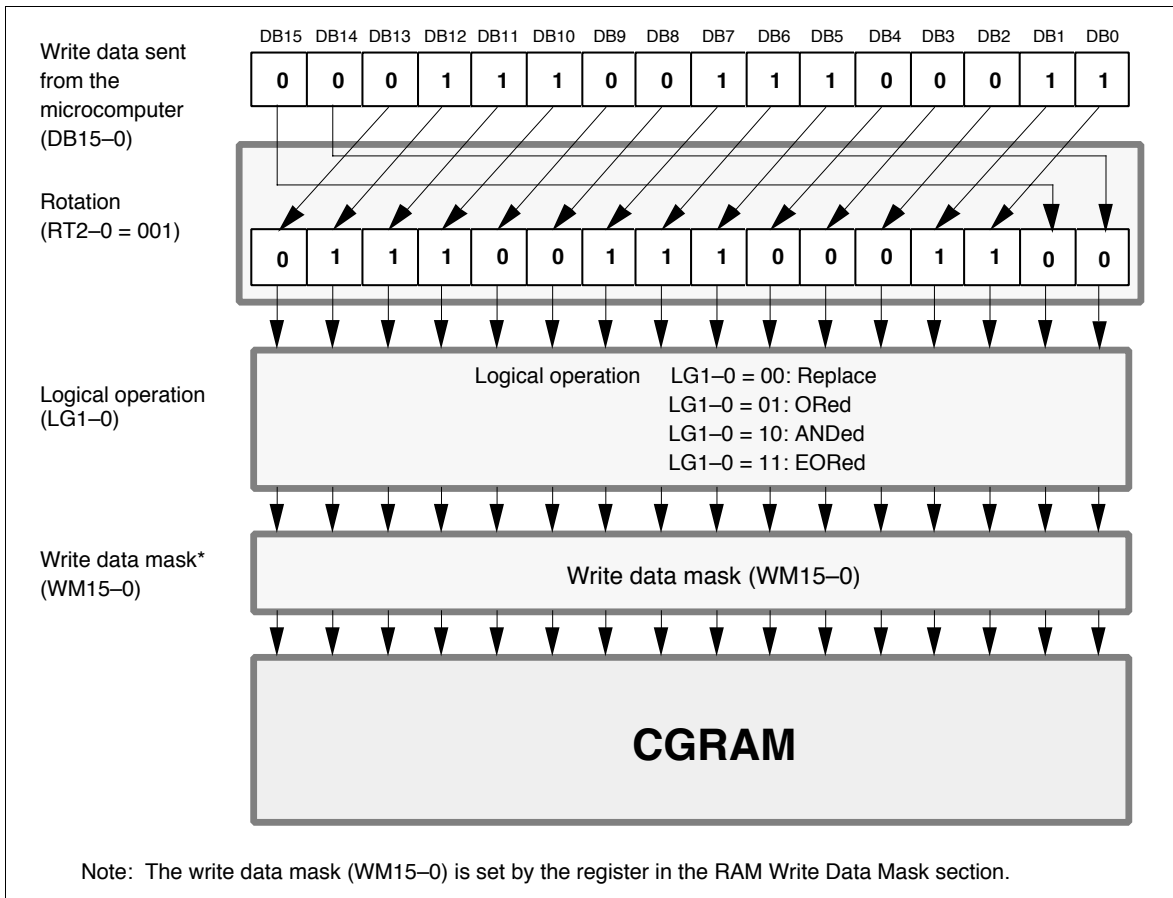

Figure 10 Logical Operation and Rotation for the CGRAM

Display Control

PS1-0: When PS1-0 = 01, only the upper eight raster-rows (COM1-COM8) are fixed-displayed in vertical smooth scrolling, and the other display raster-rows are smooth-scrolled. When PS1-0 = 10, the upper 16 raster-rows (COM1-COM16) are fixed-displayed. When PS1-0 = 11, the upper 24 raster-rows (COM1-COM24) are fixed-displayed. For details, see the Partial Smooth Scroll Display Function section.

DHE: When DHE = 1, the double height between raster-rows specified in the Double-height Display Position section is displayed. For details, see the Double-height Display section.

GS: When GS = 0, the grayscale level at a weak-colored display (DB = 01) is 1/3. When GS = 1, the grayscale level at weak-colored display is 1/2, and at strong-colored display (when DB = 10) it is 2/3.

REV: Displays all character and graphics display sections with black-and-white reversal when REV = 1. For details, see the Reversed Display Function section.

D: Display is on when D = 1 and off when D = 0. When off, the display data remains in the CGRAM, and can be displayed instantly by setting D = 1. When D is 0, the display is off with the SEG1 to SEG128 outputs and COM1 to COM128 outputs set to the GND level. Because of this, the HD66750/1 can control the charging current for the LCD with AC driving.

R/W	RS	DB15	DB14	DB13	DB12	DB11	DB10	DB9	DB8	DB7	DB6	DB5	DB4	DB3	DB2	DB1	DB0
0	1	*	*	*	*	*	*	*	*	*	*	PS1	PS0	DHE	GS	REV	D

Figure 11 Display Control Instruction

HD66750/1

Cursor Control

C: When C = 1, the window cursor display is started. The display mode is selected by the CM1–0 bits, and the display area is specified in a dot unit by the horizontal cursor position register (HS6–0 and HE6–0 bits) and vertical cursor position register (VS6–0 and VE6–0 bits). For details, see the Window Cursor Display section.

CM1–0: The display mode of the window cursor is selected. These bits can display a white-blink cursor, black-blink cursor, black-and-white reversed cursor, and black-and-white-reversed blink cursor.

R/W	RS	DB15	DB14	DB13	DB12	DB11	DB10	DB9	DB8	DB7	DB6	DB5	DB4	DB3	DB2	DB1	DB0
0	1	*	*	*	*	*	*	*	*	*	*	*	*	*	C	CM1	CM0

Figure 12 Cursor Control Instruction

Table 13 CM Bits and Window Cursor Display Mode

CM1	CM0	Window Cursor Display Mode
0	0	White-blink cursor (alternately blinking between the normal display and an all-white display (all unlit))
0	1	Black-blink cursor (alternately blinking between the normal display and an all-black display (all lit))
1	0	Black-and-white reversed cursor (black-and-white-reversed normal display (no blinking))
1	1	Black-and-white-reversed blink cursor (alternately blinking the black-and-white-reversed normal display)

Double-height Display Position

DS6–0: Specify any common raster-row position where the double-height display starts. Note that no scrolling is done by vertical scrolling. For details, see the Double-height Display section.

DE6–0: Specify any common raster-row position where the double-height display ends. Set the end position of the double-height display after the start position of the double-height display, satisfying the relationship $DS6-0 \leq DE6-0$. When the area specifying the double height has an odd number of raster-rows, the double-height display is done for the $DE6-0 + 1$ raster-rows.

When the double-height display is not used, set the DHE bit in the display-control instruction register to 0.

R/W	RS	DB15	DB14	DB13	DB12	DB11	DB10	DB9	DB8	DB7	DB6	DB5	DB4	DB3	DB2	DB1	DB0
0	1	*	DE6	DE5	DE4	DE3	DE2	DE1	DE0	*	DS6	DS5	DS4	DS3	DS2	DS1	DS0

Figure 13 Double-height Display Position Instruction

Vertical Scroll Control

SL6-0: Specify the display start raster-row for vertical smooth scrolling. Any raster-row from the first to 128th can be selected (table 14). After the 128th raster-row is displayed, the display restarts from the first raster-row. For details, see the Vertical Smooth Scroll section.

In partial smooth scrolling, these bits specify the display start raster-row of the next fixed-display raster-row. For details, see the Partial Smooth Scroll Display Function section.

R/W	RS	DB15	DB14	DB13	DB12	DB11	DB10	DB9	DB8	DB7	DB6	DB5	DB4	DB3	DB2	DB1	DB0
0	1	*	*	*	*	*	*	*	*	*	SL6	SL5	SL4	SL3	SL2	SL1	SL0

Figure 14 Vertical Scroll Control Instruction
Table 14 SL Bits and Display-start Raster-row

SL6	SL5	SL4	SL3	SL2	SL1	SL0	Display-start Raster-row
0	0	0	0	0	0	0	1st raster-row
0	0	0	0	0	0	1	2nd raster-row
0	0	0	0	0	1	0	3rd raster-row
0	0	0	0	0	1	1	4th raster-row
0	0	0	0	1	0	0	5th raster-row
:	:	:	:	:	:	:	:
1	1	1	1	1	1	0	127th raster-row
1	1	1	1	1	1	1	128th raster-row

HD66750/1

Horizontal Cursor Position

Vertical Cursor Position

HS6-0: Specify the start position for horizontally displaying the window cursor in a dot unit. The cursor is displayed from the 'set value + 1' dot. Ensure that $HS6-0 \leq HE6-0$.

HE6-0: Specify the end position for horizontally displaying the window cursor in a dot unit. The cursor is displayed to the 'set value + 1' dot. Ensure that $HS6-0 \leq HE6-0$.

VS6-0: Specify the start position for vertically displaying the window cursor in a dot unit. The cursor is displayed from the 'set value + 1' dot. Ensure that $VS6-0 \leq VE6-0$.

VE6-0: Specify the end position for vertically displaying the window cursor in a dot unit. The cursor is displayed to the 'set value + 1' dot. Ensure that $VS6-0 \leq VE6-0$. In vertical scrolling, rewrite VS6-0 and VE6-0 since this window cursor does not move vertically.

R/W	RS	DB15	DB14	DB13	DB12	DB11	DB10	DB9	DB8	DB7	DB6	DB5	DB4	DB3	DB2	DB1	DB0
0	1	*	HE6	HE5	HE4	HE3	HE2	HE1	HE0	*	HS6	HS5	HS4	HS3	HS2	HS1	HS0
0	1	*	VE6	VE5	VE4	VE3	VE2	VE1	VE0	*	VS6	VS5	VS4	VS3	VS2	VS1	VS0

Figure 15 Horizontal Cursor Position and Vertical Cursor Position Instructions

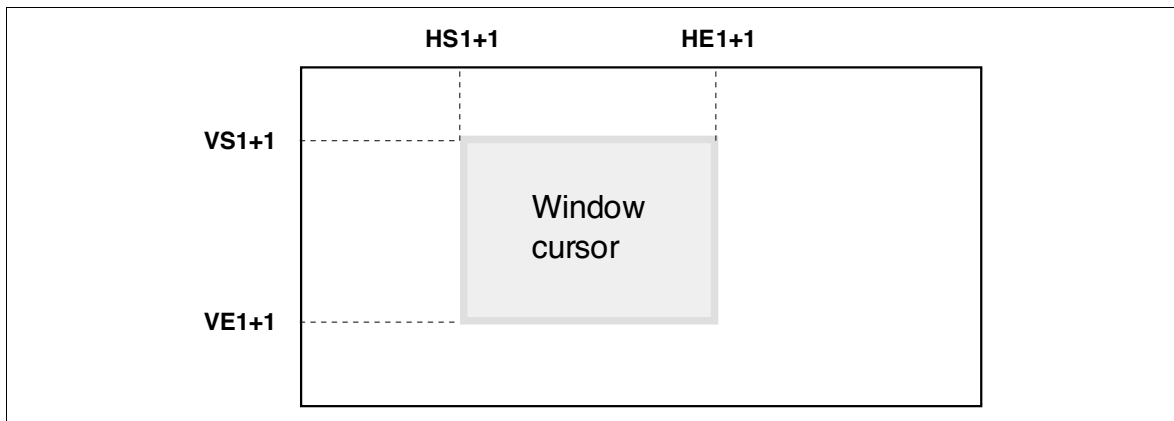

Figure 16 Window Cursor Position

RAM Write Data Mask

WM15-0: In writing to the CGRAM, these bits mask writing in a bit unit. When WM15 = 1, this bit masks the write data of DB15 and does not write to the CGRAM. Similarly, the WM14–0 bits mask the write data of DB14–0 in a bit unit. However, when AM = 10, the write data is masked with the set values of VM15–0 for the odd-times CGRAM write. It is also masked automatically with the reversed set values of VM15–0 for the even-times CGRAM write. For details, see the Graphics Operation Function section.

R/W	RS	DB15	DB14	DB13	DB12	DB11	DB10	DB9	DB8	DB7	DB6	DB5	DB4	DB3	DB2	DB1	DB0
0	1	VM 15	VM 14	VM 13	VM 12	VM 11	VM 10	VM 9	VM 8	VM 7	VM 6	VM 5	VM 4	VM 3	VM 2	VM 1	VM 0

Figure 17 RAM Write Data Mask Instruction

RAM Address Set

AD10-0: Initially set CGRAM addresses to the address counter (AC). Once the CGRAM data is written, the AC is automatically updated according to the AM1–0 and I/D bit settings. This allows consecutive accesses without resetting addresses. Once the CGRAM data is read, the AC is not automatically updated. CGRAM address setting is not allowed in the sleep mode or standby mode.

R/W	RS	DB15	DB14	DB13	DB12	DB11	DB10	DB9	DB8	DB7	DB6	DB5	DB4	DB3	DB2	DB1	DB0
0	1	*	*	*	*	*	AD 10	AD9	AD8	AD7	AD6	AD5	AD4	AD3	AD2	AD1	AD0

Figure 18 RAM Address Set Instruction

Table 15 AD Bits and CGRAM Settings

AD10–AD0	CGRAM Setting
"000"H–"00F"H	Bitmap data for COM1
"010"H–"01F"H	Bitmap data for COM2
"020"H–"02F"H	Bitmap data for COM3
"030"H–"03F"H	Bitmap data for COM4
:	:
"760"H–"76F"H	Bitmap data for COM119
"770"H–"77F"H	Bitmap data for COM120
"780"H–"78F"H	121st raster-row data (appeared at vertical scrolling)
"790"H–"79F"H	122nd raster-row data (appeared at vertical scrolling)
"7A0"H–"7AF"H	123rd raster-row data (appeared at vertical scrolling)
"7B0"H–"7BF"H	124th raster-row data (appeared at vertical scrolling)
"7C0"H–"7CF"H	125th raster-row data (appeared at vertical scrolling)
"7D0"H–"7DF"H	126th raster-row data (appeared at vertical scrolling)
"7E0"H–"7EF"H	127th raster-row data (appeared at vertical scrolling)
"7F0"H–"7FF"H	128th raster-row data (appeared at vertical scrolling)

HD66750/1

Write Data to CGRAM

WD15-0 : Write 16-bit data to the CGRAM. After a write, the address is automatically updated according to the AM1-0 and I/D bit settings. During the sleep and standby modes, the CGRAM cannot be accessed.

R/W	RS	DB15	DB14	DB13	DB12	DB11	DB10	DB9	DB8	DB7	DB6	DB5	DB4	DB3	DB2	DB1	DB0
0	1	WD 15	WD 14	WD 13	WD 12	WD 11	WD 10	WD 9	WD 8	WD 7	WD 6	WD 5	WD 4	WD 3	WD 2	WD 1	WD 0

Figure 19 Write Data to CGRAM Instruction

Read Data from CGRAM

RD15-0 : Read 16-bit data from the CGRAM. When the data is read to the microcomputer, the first-word read immediately after the CGRAM address setting is latched from the CGRAM to the internal read-data latch. The data on the data bus (DB15-0) becomes invalid and the second-word read is normal.

When bit processing, such as a logical operation, is performed within the HD66750/1, only one read can be processed since the latched data in the first word is used.

R/W	RS	DB15	DB14	DB13	DB12	DB11	DB10	DB9	DB8	DB7	DB6	DB5	DB4	DB3	DB2	DB1	DB0
1	1	RD 15	RD 14	RD 13	RD 12	RD 11	RD 10	RD 9	RD 8	RD 7	RD 6	RD 5	RD 4	RD 3	RD 2	RD 1	RD 0

Figure 20 Read Data from CGRAM Instruction

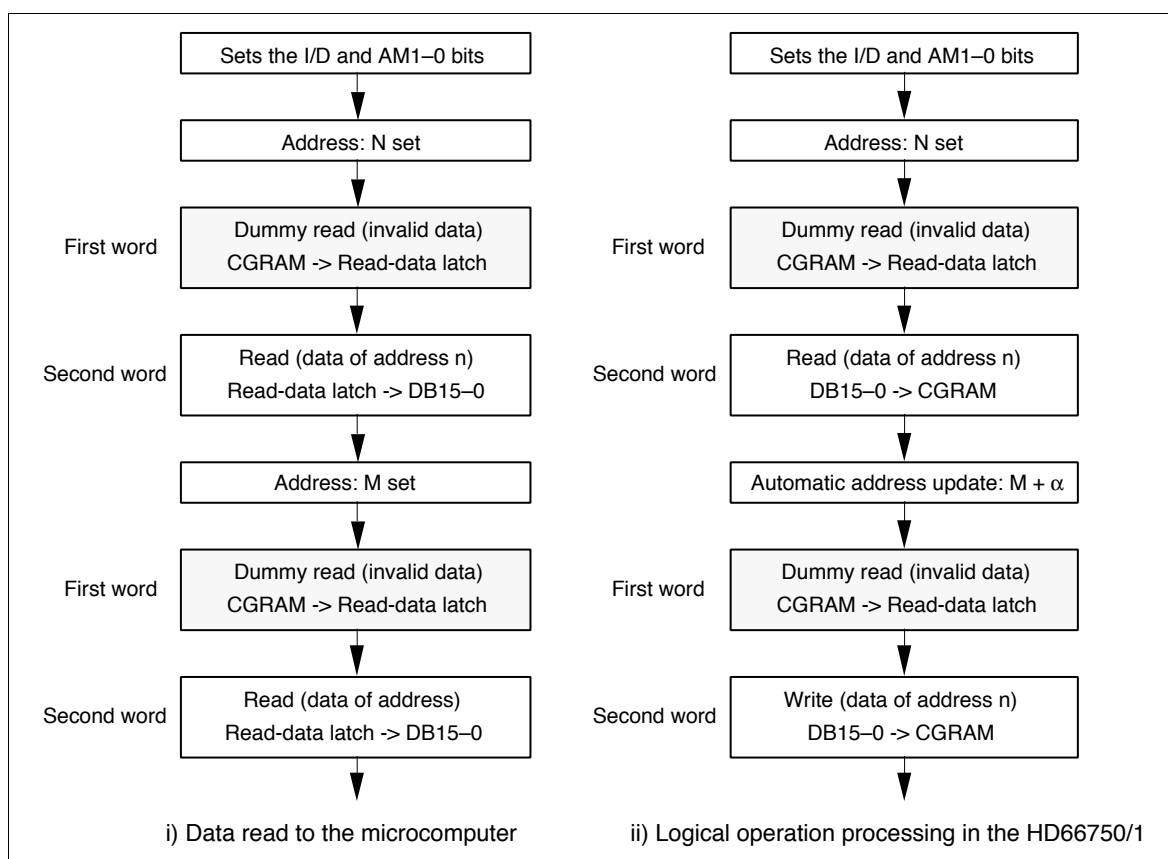

Figure 21 CGRAM Read Sequence

Reset Function

The HD66750/1 is internally initialized by RESET input. Because the busy flag (BF) indicates a busy state (BF = 1) during the reset period, no instruction or CGRAM data access from the MPU is accepted. The reset input must be held for at least 1 ms. Do not access the CGRAM or initially set the instructions until the R-C oscillation frequency is stable after power has been supplied (10 ms).

Instruction Set Initialization:

1. Start oscillation executed
2. Driver output control (CN = 0, NL3-0 = 1111, SGS = 0, CMS = 0)
3. B-pattern waveform AC drive (B/C = 0, ECR = 0, NW4-0 = 00000)
4. Power control (DC1-0 = 00, AP1-0 = 00: LCD power off, SLP = 0: Sleep mode off, STB = 0: Standby mode off)
5. 1/11 bias drive (BS2-0 = 000), Two-times boost (BT1-0 = 00), Weak contrast (CT5-0 = 000000)
6. Entry mode set (I/D = 1: Increment by 1, AM1-0 = 00: Horizontal move, LG1-0 = 00: Replace mode)
7. Rotation (RT2-0 = 000: No shift)
8. Display control (DHE = 0: Double-height display off, REV = 0, GS = 0, D = 0: Display off, PS1-0 = 00: Partial scroll off)
9. Cursor control (C = 0: Cursor display off, CM1-0 = 00: White blink cursor)
10. Double-height display position (DS6-0 = 0000000, DE6-0 = 0000000)
11. Vertical scroll control (SL6-0 = 0000000: First raster-row displayed at the top)
12. Window cursor display position (HS6-0 = HE6-0 = VS6-0 = VE6-0 = 0000000)
13. RAM write data mask (WM15-0 = 0000H: No mask)
14. RAM address set (AD10-0 = 000H)

CGRAM Data Initialization:

This is not automatically initialized by reset input but must be initialized by software while display is off (D = 0).

Output Pin Initialization:

1. LCD driver output pins (SEG/COM): Outputs GND level
2. Booster output pins (VLOUT): Outputs Vcc level
3. Oscillator output pin (OSC2): Outputs oscillation signal

HD66750/1

Parallel Data Transfer

16-bit Bus Interface

Setting the IM2-0 (interface mode) to the GND/GND level allows 68-system E-clock-synchronized 16-bit parallel data transfer. Setting the IM1/0 to the Vcc/GND level allows 80-system 16-bit parallel data transfer. When the number of buses or the mounting area is limited, use an 8-bit bus interface.

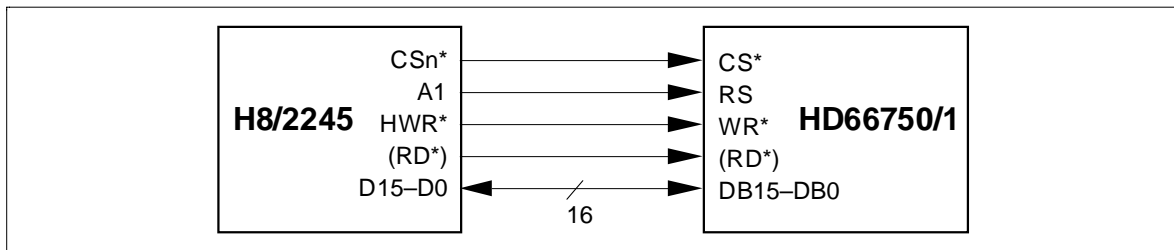

Figure 22 Interface to 16-bit Microcomputer

8-bit Bus Interface

Setting the IM1/0 (interface mode) to the GND/Vcc level allows 68-system E-clock-synchronized 8-bit parallel data transfer using pins DB15-DB8. Setting the IM1/0 to the Vcc/Vcc level allows 80-system 8-bit parallel data transfer. The 16-bit index register, instructions and RAM data are divided into eight upper/lower bits and the transfer starts from the upper eight bits. Fix unused pins DB7-DB0 to the Vcc or GND level.

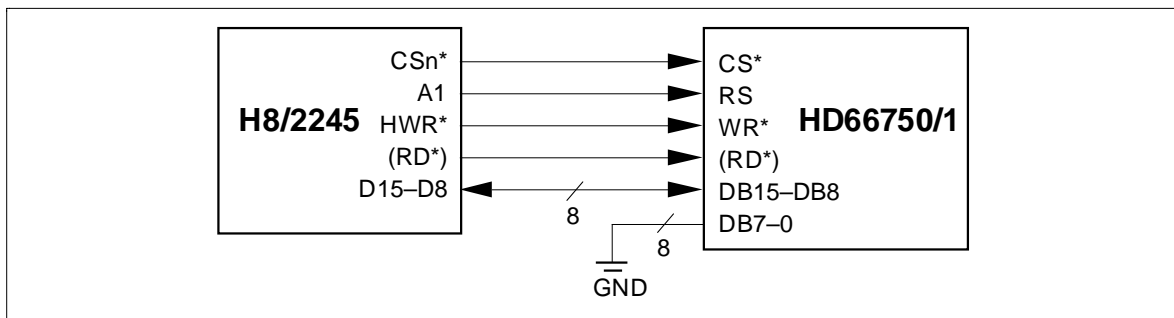

Figure 23 Interface to 8-bit Microcomputer

Note: Transfer synchronization function for an 8-bit bus interface

The HD66750/1 supports the transfer synchronization function which resets the upper/lower counter to count upper/lower 8-bit data transfer in the 8-bit bus interface. Noise causing transfer mismatch between the eight upper and lower bits can be corrected by a reset triggered by consecutively writing a 00H instruction four times. The next transfer starts from the upper eight bits. Executing synchronization function periodically can recover any runaway in the display system.

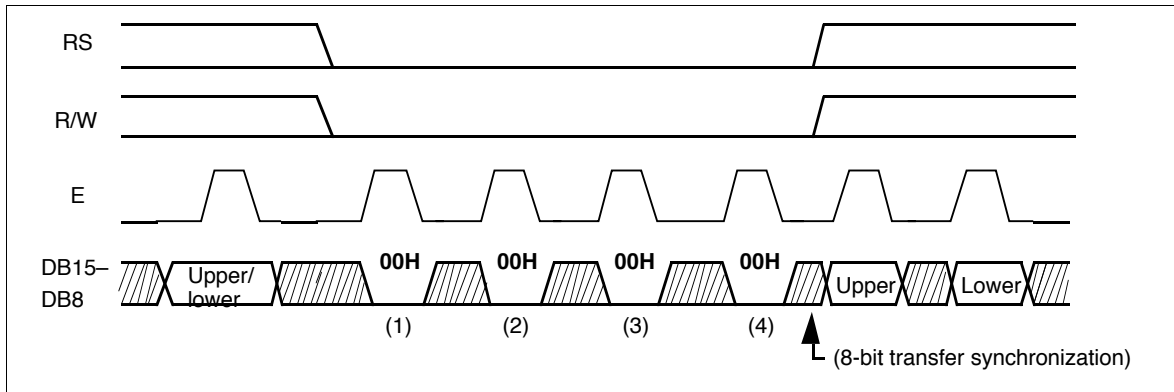

Figure 24 8-bit Transfer Synchronization

HD66750/1

Graphics Operation Function

The HD66750/1 can greatly reduce the load of the microcomputer graphics software processing through the 16-bit bus architecture and graphics-bit operation function. This function supports the following:

1. A write data mask function that selectively rewrites some of the bits in the 16-bit write data.
2. A bit rotation function that shifts and writes the data sent from the microcomputer in a bit unit.
3. A logical operation function that writes the data sent from the microcomputer and the original RAM data by a logical operation.

Since the display data in the graphics RAM (CGRAM) can be quickly rewritten, the load of the microcomputer processing can be reduced in the large display screen when a font pattern, such as kanji characters, is developed for any position (BITBLT processing).

The graphics bit operation can be controlled by combining the entry mode register, the bit set value of the RAM-write-data mask register, and the read/write from the microcomputer.

Table 17 Graphics Operation

Operation Mode	Bit Setting			Operation and Usage
	I/D	AM	LG	
Write mode 1	0/1	00	00	Horizontal data replacement, horizontal-border drawing
Write mode 2	0/1	01	00	Vertical data replacement, font development, vertical-border drawing
Write mode 3	0/1	10	00	Vertical data replacement with two-word width, kanji-font development
Read/write mode 1	0/1	00	01 10 11	Horizontal data replacement with logical operation, horizontal-border drawing
Read/write mode 2	0/1	01	01 10 11	Vertical data replacement with logical operation, vertical-border drawing
Read/write mode 3	0/1	10	01 10 11	Horizontal data replacement with two-word-width logical operation

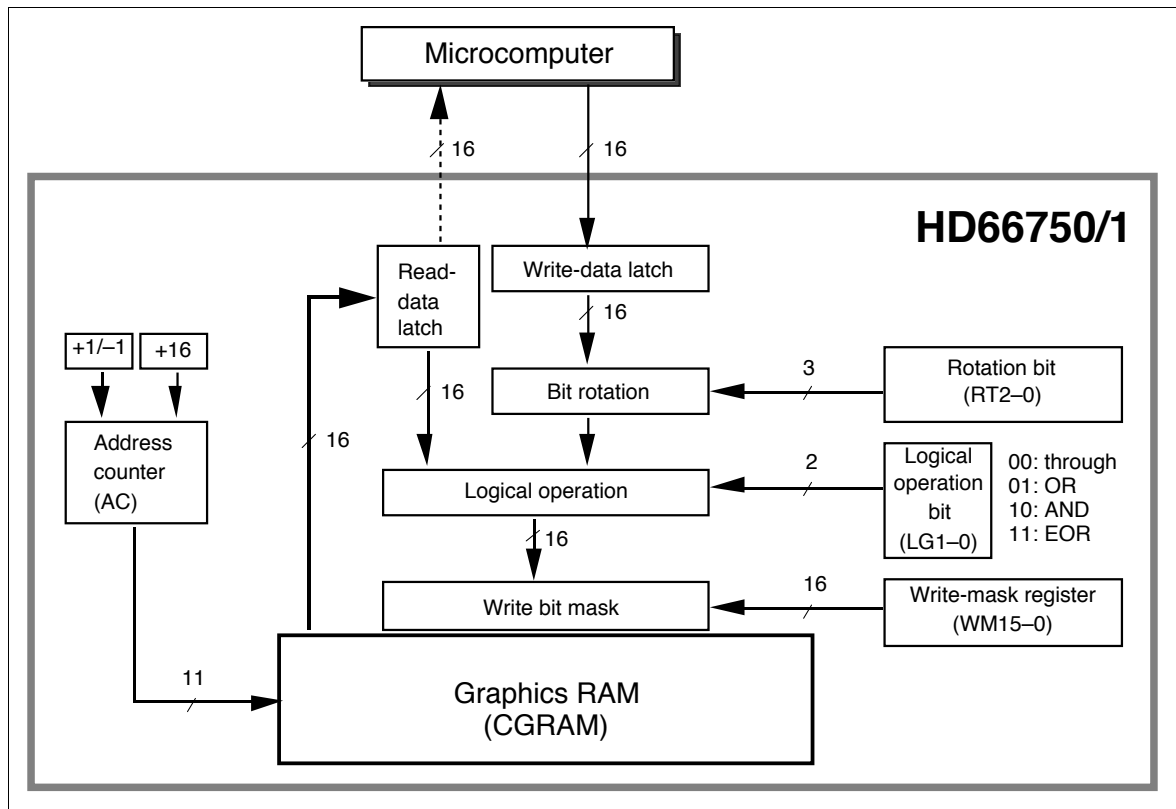

Figure 25 Data Processing Flow of the Graphics Bit Operation

1. Write mode 1: AM1-0 = 00, LG1-0 = 00

This mode is used when the data is horizontally written at high speed. It can also be used to initialize the graphics RAM (CGRAM) or to draw borders. The rotation function (RT2-0) or write-data mask function (WM15-0) are also enabled in these operations. After writing, the address counter (AC) automatically increments by 1 (I/D = 1) or decrements by 1 (I/D = 0), and automatically jumps to the counter edge one-raster-row below after it has reached the left edge of the graphics RAM.

Operation Examples:

- 1) I/D = 1, AM1-0 = 00, LG1-0 = 00, RT2-0 = 000
- 2) WM15-0 = 0000H
- 3) AC = 000H

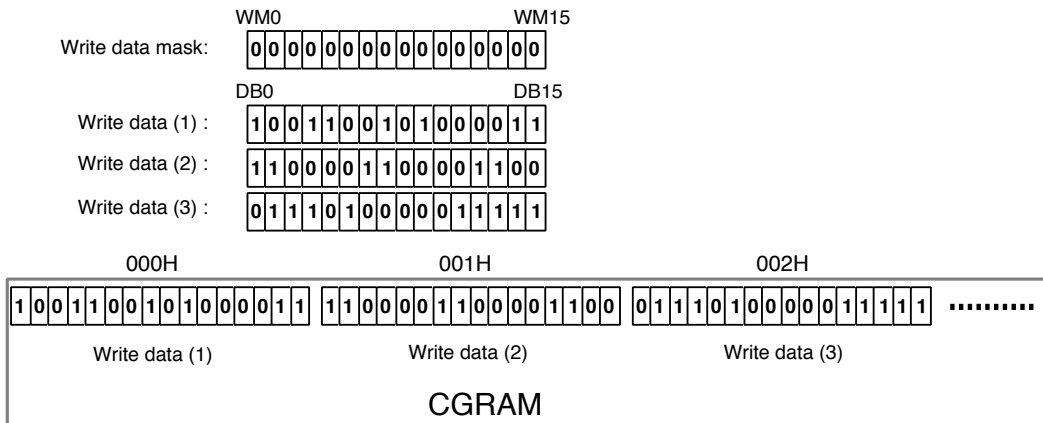

Figure 26 Writing Operation of Write Mode 1

2. Write mode 2: AM1-0 = 01, LG1-0 = 00

This mode is used when the data is vertically written at high speed. It can also be used to initialize the graphics RAM (CGRAM), develop the font pattern in the vertical direction, or draw borders. The rotation function (RT2-0) or write-data mask function (WM15-0) are also enabled in these operations. After writing, the address counter (AC) automatically increments by 16, and automatically jumps to the upper-right edge (I/D = 1) or upper-left edge (I/D = 0) following the I/D bit after it has reached the lower edge of the graphics RAM.

Operation Examples:

- 1) I/D = 1, AM1-0 = 01, LG1-0 = 00, RT2-0 = 010
- 2) WM15-0 = F007H
- 3) AC = 000H

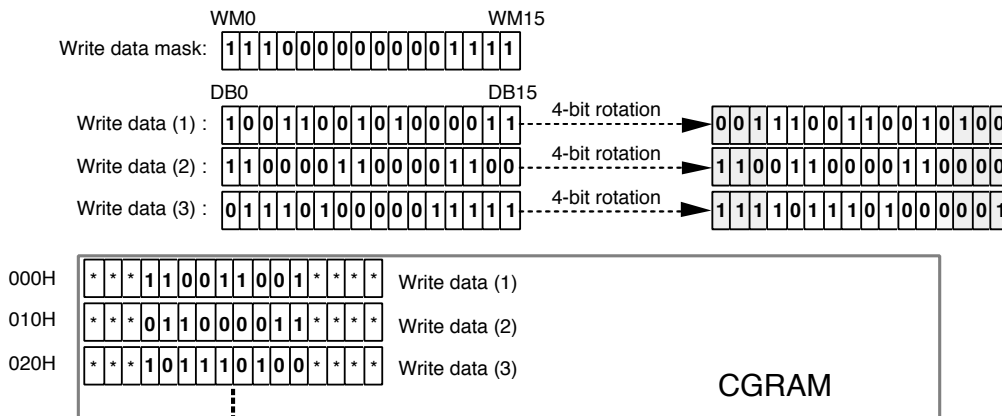

- Notes: 1. The bit area data in the RAM indicated by "*" is not changed.
- 2. After writing to address 7F0H, the AC jumps to 001H.

Figure 27 Writing Operation of Write Mode 2

3. Write mode 3: AM1-0 = 10, LG1-0 = 00

This mode is used when the data is written at high speed by vertically shifting bits. It can also be used to write the 16-bit data for two words into the graphics RAM (CGRAM), develop the font pattern, or transfer the BitBLT as a bit unit. The rotation function (RT2-0) or write-data mask function (WM15-0) are also enabled in these operation. However, although the write-data mask function masks the bit position set with the write-data mask register (WM15-0) at the odd-times (such as the first or third) write, the function masks the bit position that reversed the setting value of the write-data mask register (WM15-0) at the even-times (such as the second or fourth) write. After the odd-times writing, the address counter (AC) automatically increments by 1 (I/D = 1) or decrements by 1 (I/D = 0). After the even-times writing, the AC automatically increments or decrements by -1 + 16 (I/D = 1) or +1 + 16 (I/D = 0). The AC automatically jumps to the upper edge after it has reached the lower edge of the graphics RAM.

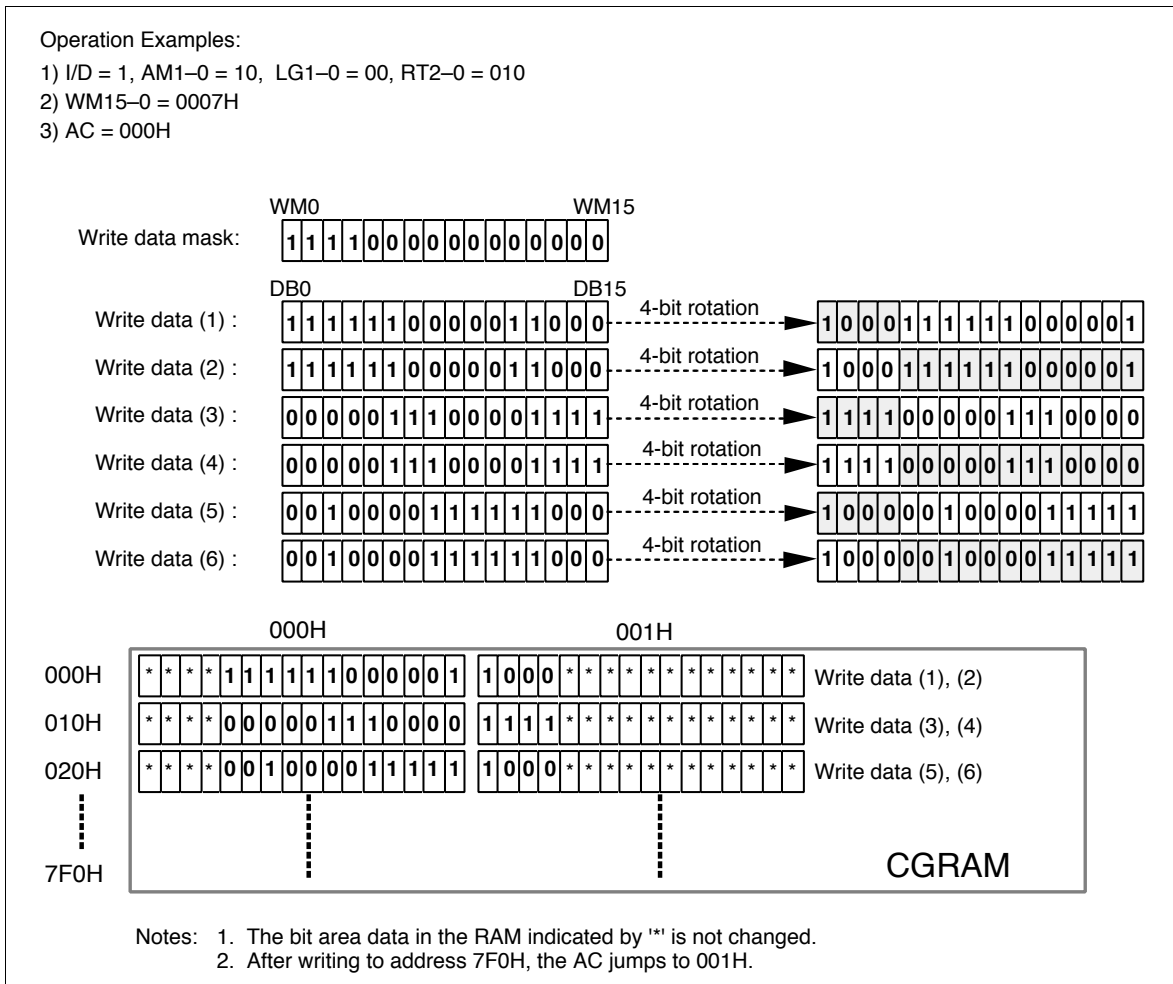

Figure 28 Writing Operation of Write Mode 3

HD66750/1

4. Read/Write mode 1: AM1-0 = 00, LG1-0 = 01/10/11

This mode is used when the data is horizontally written at high speed by performing a logical operation with the original data. It reads the display data (original data), which has already been written in the graphics RAM (CGRAM), performs a logical operation with the write data sent from the microcomputer, and rewrites the data to the CGRAM. This mode can read the data during the same bus cycle as for the write operation since the read operation of the original data does not latch the read data into the microcomputer and temporarily holds it in the read-data latch. The rotation function (RT2-0) or write-data mask function (WM15-0) are also enabled in these operations. After writing, the address counter (AC) automatically increments by 1 (I/D = 1) or decrements by 1 (I/D = 0), and automatically jumps to the counter edge one-raster-row below after it has reached the left or right edges of the graphics RAM.

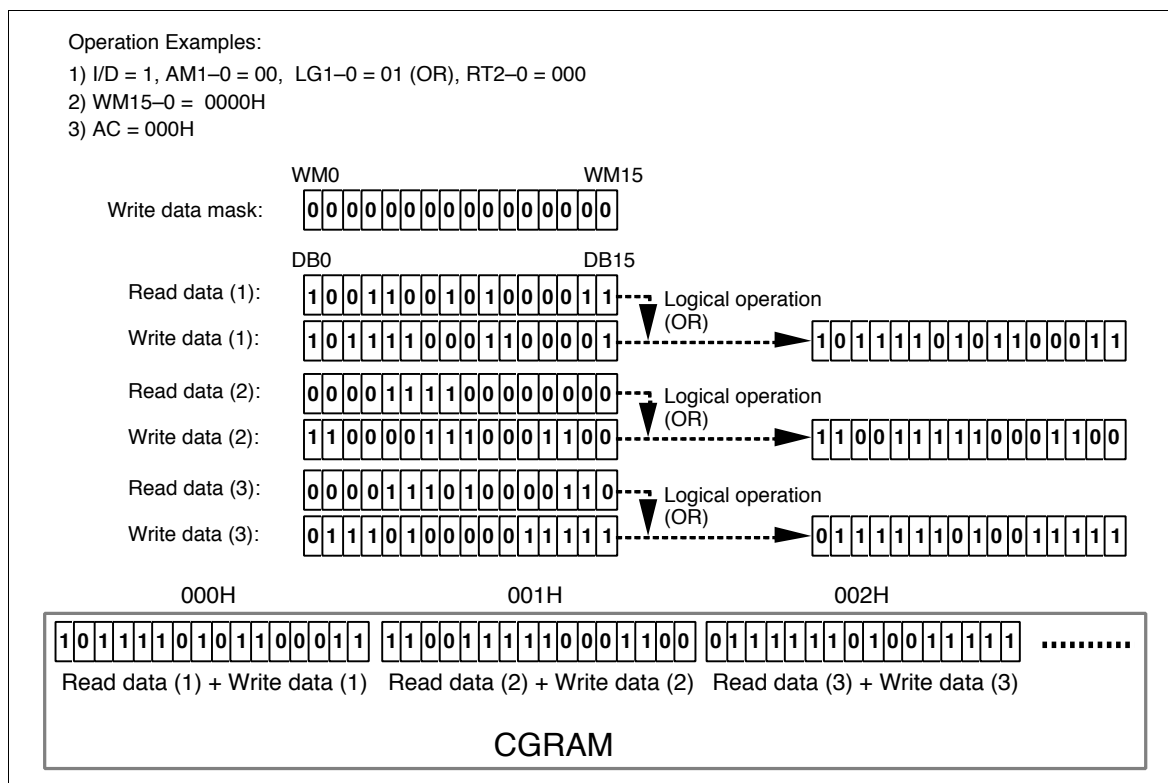

Figure 29 Writing Operation of Read/Write Mode 1

5. Read/Write mode 2: AM1-0 = 01, LG1-0 = 01/10/11

This mode is used when the data is vertically written at high speed by performing a logical operation with the original data. It reads the display data (original data), which has already been written in the graphics RAM (CGRAM), performs a logical operation with the write data sent from the microcomputer, and rewrites the data to the CGRAM. This mode can read the data during the same bus cycle as for the write operation since the read operation of the original data does not latch the read data into the microcomputer and temporarily holds it in the read-data latch. The rotation function (RT2-0) or write-data mask function (WM15-0) are also enabled in these operations. After writing, the address counter (AC) automatically increments by 16, and automatically jumps to the upper-right edge (I/D = 1) or upper-left edge (I/D = 0) following the I/D bit after it has reached the lower edge of the graphics RAM.

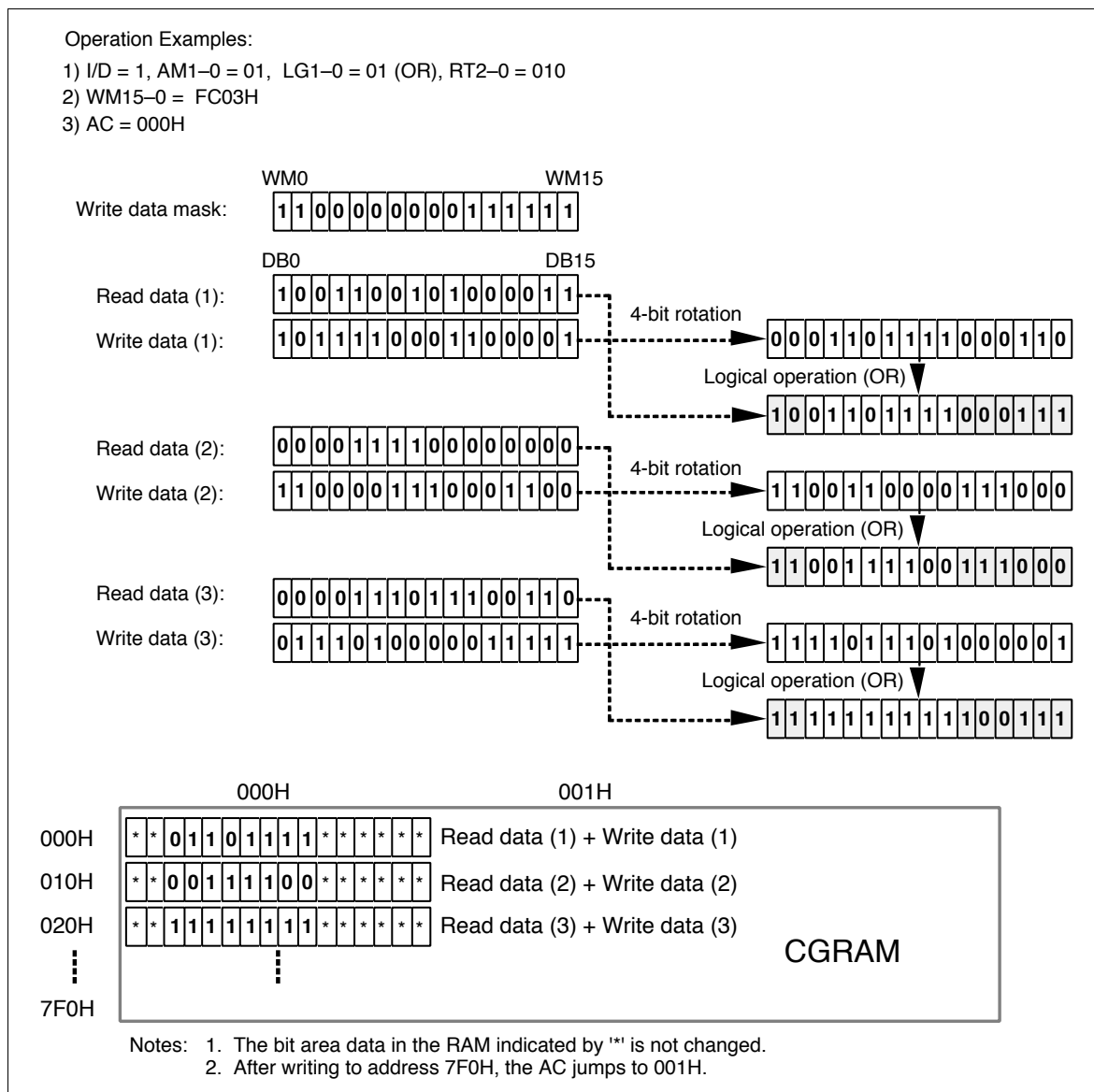

Figure 30 Writing Operation of Read/Write Mode 2

6. Read/Write mode 3: AM1-0 = 10, LG1-0 = 01/10/11

This mode is used when the data is written with high speed by vertically shifting bits and by performing logical operation with the original data. It can be also used to write the 16-bit data for two words into the graphics RAM (CGRAM), develop the font pattern, or transfer the BiTBLT as a bit unit. This mode can read the data during the same bus cycle as for the write operation since the read operation of the original data does not latch the read data into the microcomputer and temporarily holds it in the read-data latch. The rotation function (RT2-0) or write-data mask function (WM15-0) are also enabled in these operations. However, although the write-data mask function masks the bit position set with the write-data mask register (WM15-0) at the odd-times (such as the first or third) write, the function masks the bit position which reversed the setting value of the write-data mask register (WM15-0) at the even-times (such as the second or fourth) write. After the odd-times writing, the address counter (AC) automatically increments by 1 (I/D = 1) or decrements by 1 (I/D = 0). After the even-times writing, the AC automatically increments or decrements by -1 + 16 (I/D = 1) or +1 + 16 (I/D = 0). The AC automatically jumps to the upper edge after it has reached the lower edge of the graphics RAM.

HD66750/1

Operation Examples:

- 1) I/D = 1, AM1-0 = 10, LG1-0 = 01, RT2-0 = 010
- 2) WM15-0 = 000FH
- 3) AC = 000H

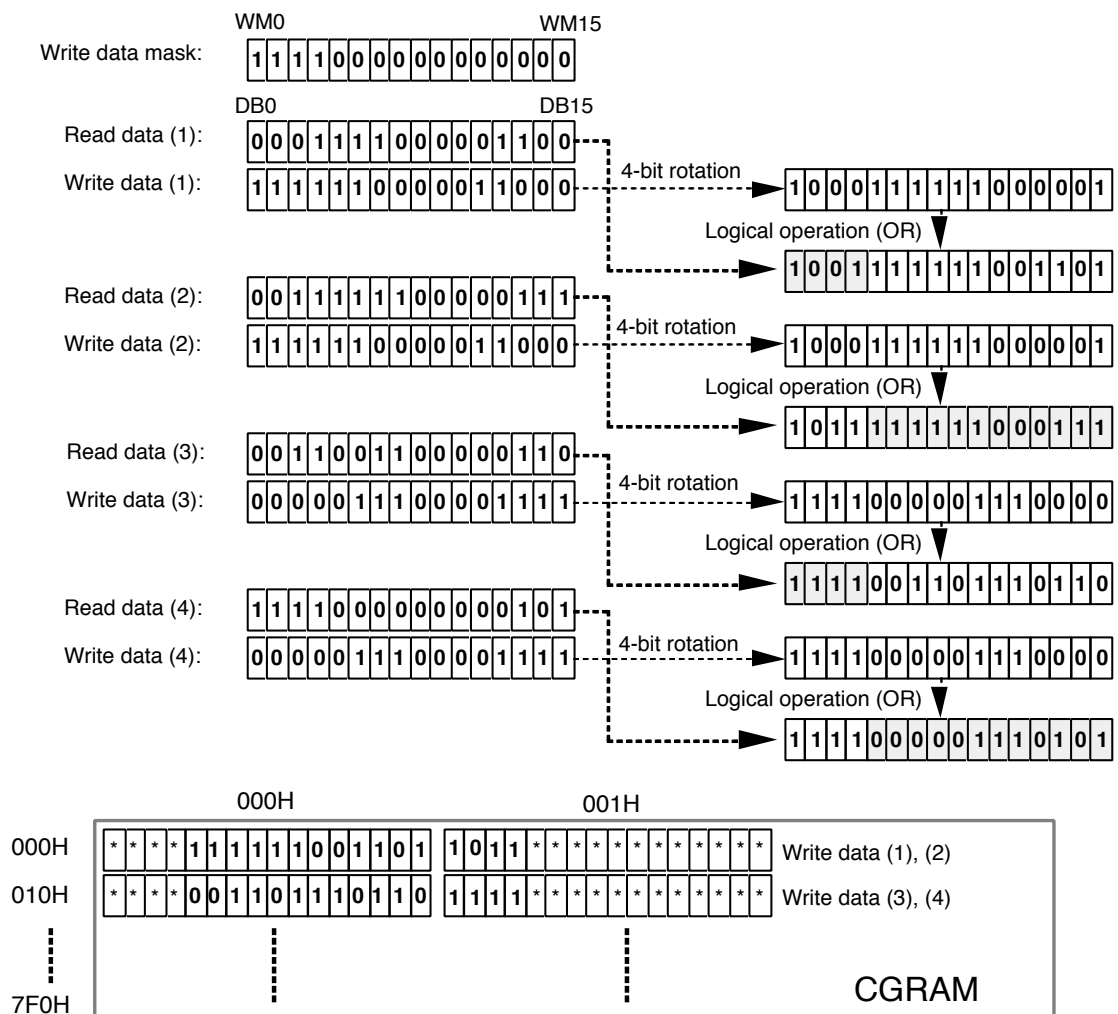

- Notes:
1. The bit area data in the RAM indicated by "*" is not changed.
 2. After writing to address 7F0H, the AC jumps to 001H.

Figure 31 Writing Operation of Read/Write Mode 3

Oscillation Circuit

The HD66750/1 can either be supplied with operating pulses externally (external clock mode) or oscillate using an internal R-C oscillator with an external oscillator-resistor (external resistor oscillation mode). Note that in R-C oscillation, the oscillation frequency is changed according to the internal capacitance value, the external resistance value, or operating power-supply voltage.

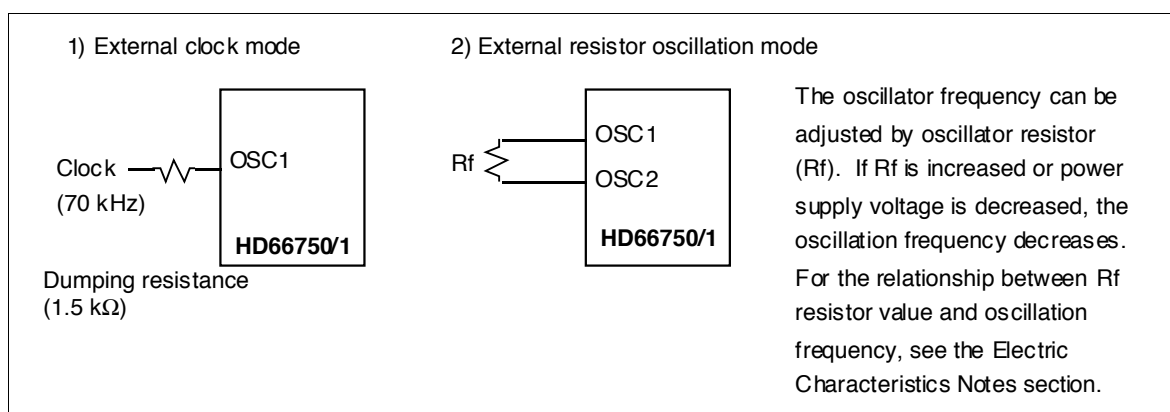

Figure 32 Oscillation Circuits

Table 18 Relationship between Liquid Crystal Drive Duty Ratio and Frame Frequency

LCD Duty	NL3-0 Set Value	Recommended Drive Bias Value	Frame Frequency	One-frame Clock
1/16	0001	1/6	70 Hz	1024
1/24	0010	1/6	70 Hz	1032
1/32	0011	1/6	70 Hz	1024
1/40	0100	1/7	69 Hz	1040
1/48	0101	1/8	71 Hz	1008
1/56	0110	1/8	71 Hz	1008
1/64	0111	1/9	70 Hz	1024
1/72	1000	1/9.5	71 Hz	1008
1/80	1001	1/10	69 Hz	1040
1/88	1010	1/10	68 Hz	1056
1/96	1011	1/10	68 Hz	1056
1/104	1100	1/11	69 Hz	1040
1/112	1101	1/11	71 Hz	1008
1/120	1110	1/11	67 Hz	1080
1/128	1111	1/11	70 Hz	1024

Note: The frame frequency above is for 72-kHz operation and proportions the oscillation frequency (fosc).

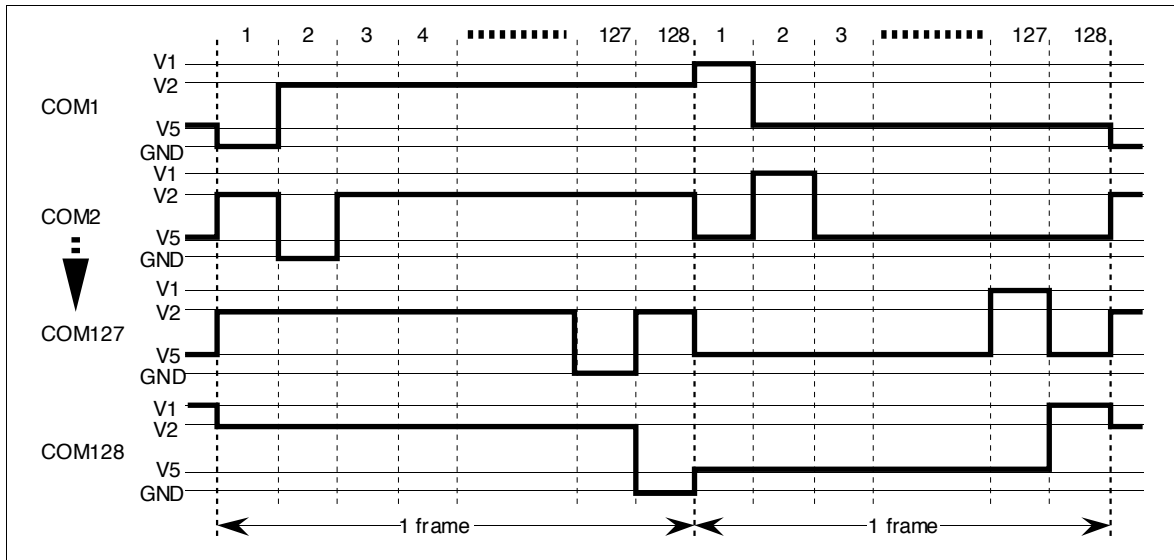

Figure 33 LCD Drive Output Waveform (B-pattern AC Drive with 1/128 Multiplexing Duty Ratio)

n-raster-row Reversed AC Drive

The HD66750/1 supports not only the LCD reversed AC drive in a one-frame unit (B-pattern waveform) but also the n-raster-row reversed AC drive which alternates in an n-raster-row unit from one to 32 raster-rows (C-pattern waveform). When a problem affecting display quality occurs, such as crosstalk at high-duty driving of more than 1/64 duty, the n-raster-row reversed AC drive (C-pattern waveform) can improve the quality. Determine the number of raster-rows n (NWbit set value + 1) for alternating after confirmation of the display quality with the actual LCD panel. However, if the number of AC raster-rows is reduced, the LCD alternating frequency becomes high. Because of this, the charge or discharge current is increased in the LCD cells.

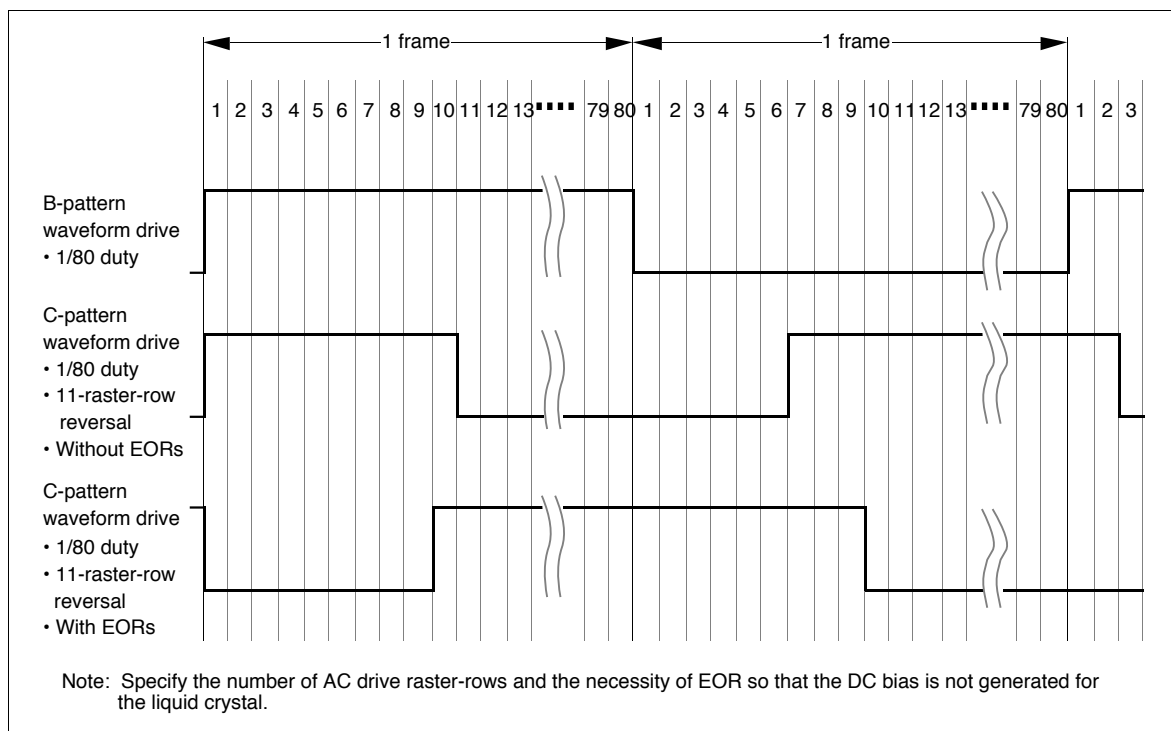

Figure 34 Example of an AC Signal under n-raster-row Reversed AC Drive

HD66750/1

Liquid Crystal Display Voltage Generator

When External Power Supply and Internal Operational Amplifiers are Used

To supply LCD drive voltage directly from the external power supply without using the internal booster, circuits should be connected as shown in figure 35. Here, contrast can be adjusted by software through the CT bits of the contrast adjustment register.

The HD66750/1 incorporates a voltage-follower operational amplifier for each V1 to V5 to reduce current flowing through the internal bleeder-resistors, which generate different levels of liquid-crystal drive voltages. Thus, potential difference between V_{LCD} and V1 must be 0.1 V or higher, and that between V4 and GND must be 1.4 V or higher. Note that the OPOFF pin must be grounded when using the operational amplifiers. Place a capacitor of about 0.47 μ F (B characteristics) between each internal operational amplifier (V1OUT to V5OUT outputs) and GND and stabilize the output level of the operational amplifier. Adjust the capacitance value of the stabilized capacitor after the LCD panel has been mounted and the screen quality has been confirmed.

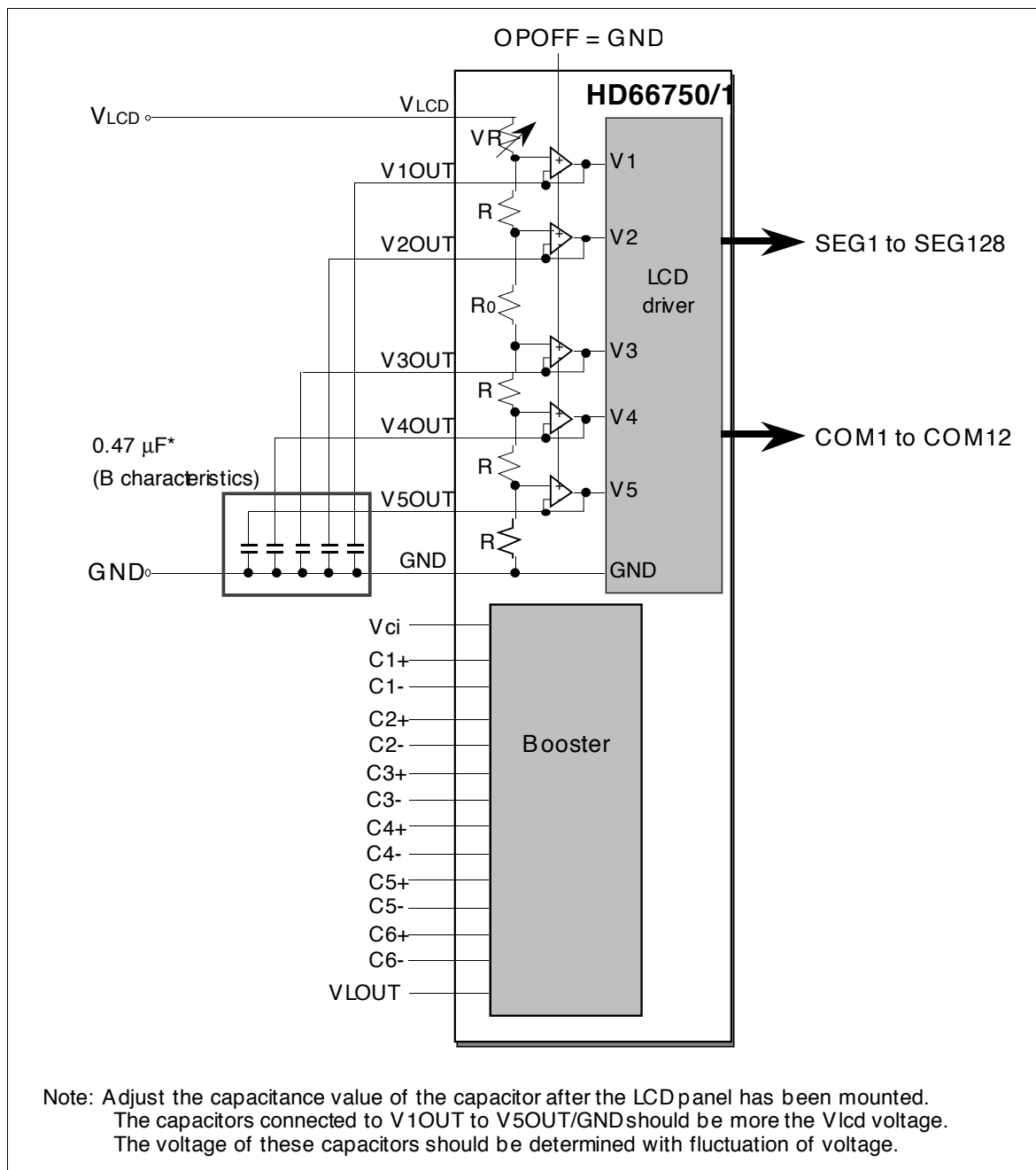

Figure 35 External Power Supply Circuit for LCD Drive Voltage Generation

When an Internal Booster and Internal Operational Amplifiers are Used

To supply LCD drive voltage using the internal booster, circuits should be connected as shown in figure 36. Here, contrast can be adjusted through the CT bits of the contrast control instruction. Temperature can be compensated either through the CT bits or by controlling the reference voltage for the booster (V_{ci} pin) using a thermistor.

Note that V_{ci} is both a reference voltage and power supply for the booster. The reference voltage must therefore be adjusted using an emitter-follower or a similar element so that sufficient current can be supplied. In this case, V_{ci} must be equal to or smaller than the V_{CC} level.

HD66750/1

The HD66750/1 incorporates a voltage-follower operational amplifier for each of V1 to V5 to reduce current flowing through the internal bleeder-resistors, which generate different liquid-crystal drive voltages. Thus, potential difference between V_{LCD} and V1 must be 0.1 V or higher, and that between V4 and GND must be 1.4 V or higher. Note that the OPOFF pin must be grounded when using the operational amplifiers. Place a capacitor of about 0.47 μF (B characteristics) between each internal operational amplifier (V1OUT to V5OUT outputs) and GND and stabilize the output level of the operational amplifier. Adjust the capacitance value of the stabilized capacitor after the LCD panel has been mounted and the screen quality has been confirmed.

HD66750/1

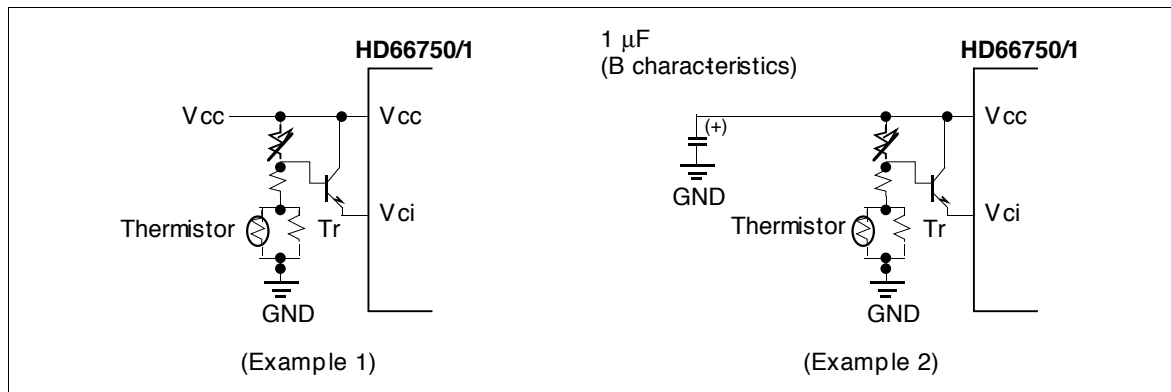

Figure 37 Temperature Compensation Circuits

Switching the Boosting Factor

Instruction bits (BT1/0 bits) can optionally select the boosting factor of the internal booster. According to the display status, power consumption can be reduced by changing the LCD drive duty and the LCD drive bias, and by controlling the boosting factor for the minimum requirements. For details, see the Partial-display-on Function section.

Because of the maximum boosting factor, external capacitors need to be connected. For example, when the maximum boosting is six times or five times, capacitors between C6+ and C6– or between C5+ and C5– are needed as well, as in the case of the seven-times boosting. When the boosting is two-times boosting, capacitors between C1+ and C1– or between C4+ and C4– are not needed.

Place a capacitor with a voltage of three times or more the Vci-GND voltage between C6+ and C6– and between C3+ and C3–, and a capacitor with a voltage larger than the Vci-GND voltage between C1+ and C1–, C2+ and C2–, C4+ and C4–, and C5+ and C5–.

Place a capacitor with a voltage of N times the Vci-GND voltage between VLOUT and GND. (N: boosting factor)

Note that each capacitors with a voltage should be determined with a voltage fluctuation.

Table 19 VLOUT Output Status

BT1	BT0	VLOUT Output Status
0	0	Two-times boosting output
0	1	Five-times boosting output
1	0	Six-times boosting output
1	1	Seven-times boosting output

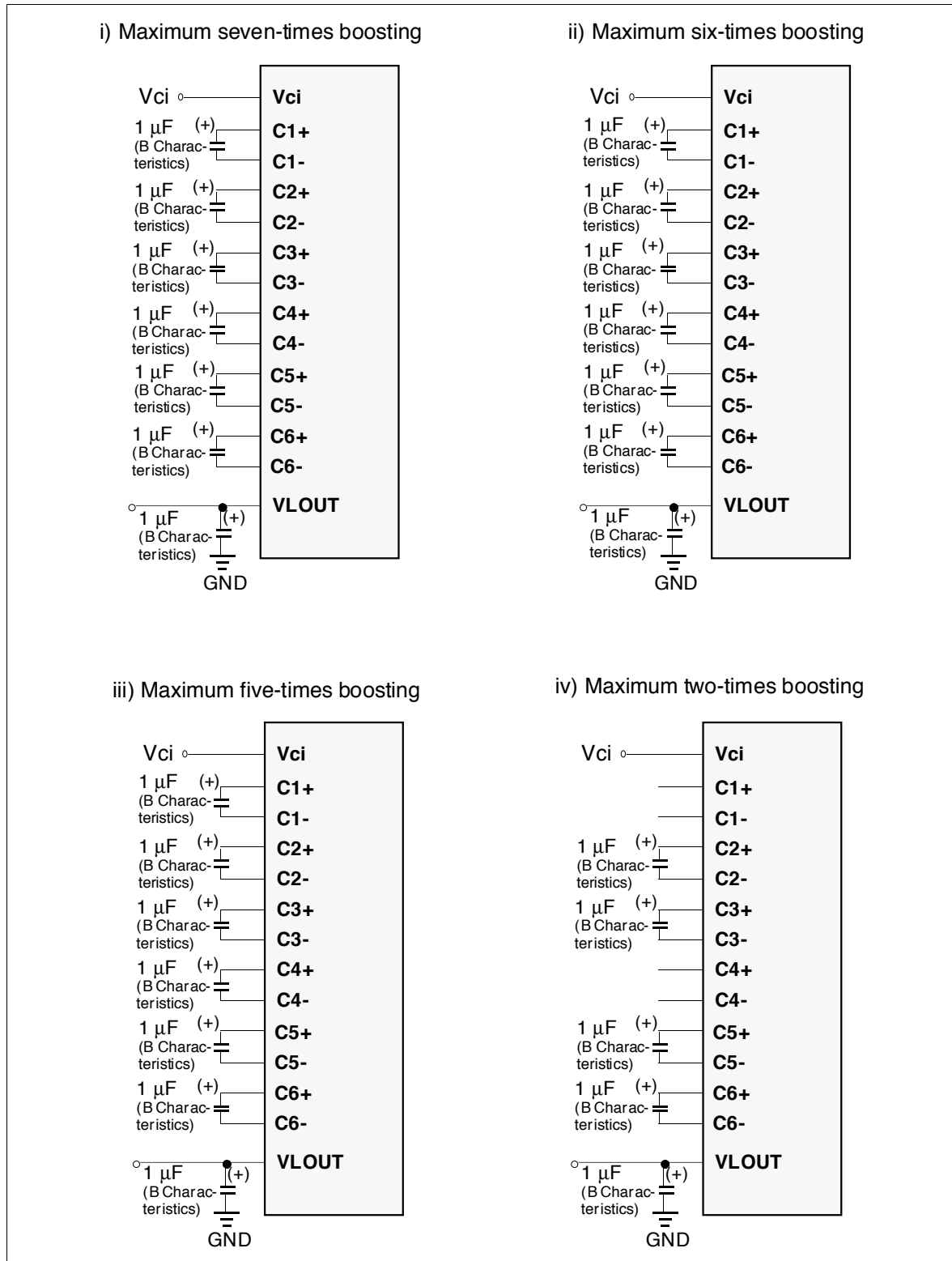

Figure 38 Booster Output Factor Switching

HD66750/1

Example of Power-supply Voltage Generator for More Than Seven-times Boosting Output

The HD66750/1 incorporates a booster for up to seven-times boosting. However, the LCD drive voltage (VLCD) will not be enough for seven-times boosting from V_{CC} when the power-supply voltage of V_{CC} is low or when the LCD drive voltage is high for the high-contrast LCD display. In this case, the reference voltage (V_{ci}) for boosting can be set higher than the power-supply voltage of V_{CC} .

When the boosting factor is high, the current driving ability is lowered and insufficient display quality may result. In this case, the boosting ability can be improved by decreasing the boosting factor as shown in the booster in figure 39.

Set the V_{ci} input voltage for the booster to 3.6 V or less within the range of $V_{CC} + 1.0$ V. Control the V_{ci} voltage so that the boosting output voltage (VLOUT) should be less than the absolute maximum ratings (16.5 V).

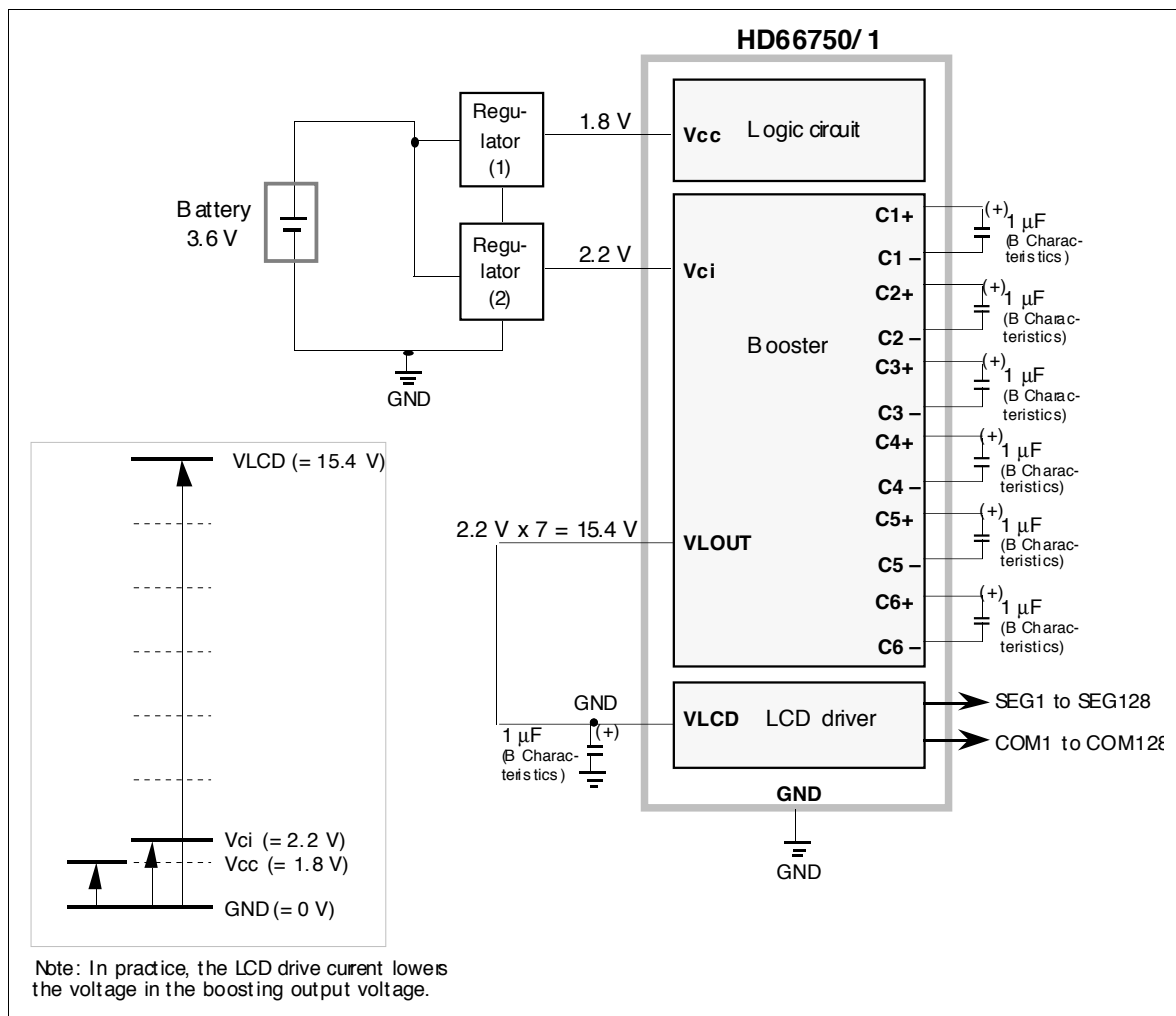

Figure 39 Usage Example of Booster at $V_{ci} > V_{CC}$

Contrast Adjuster

Software can adjust 64-step contrast for an LCD by varying the liquid-crystal drive voltage (potential difference between V_{LCD} and $V1$) through the CT bits of the contrast adjustment register (electron volume function). The value of a variable resistor between V_{LCD} and $V1$ (VR) can be precisely adjusted in a $0.05 \times R$ unit within a range from $0.05 \times R$ through $3.20 \times R$, where R is a reference resistance obtained by dividing the total resistance.

The HD66750/1 incorporates a voltage-follower operational amplifier for each of $V1$ to $V5$ to reduce current flowing through the internal bleeder resistors, which generate different liquid-crystal drive voltages. Thus, CT5-0 bits must be adjusted so that potential difference between V_{LCD} and $V1$ is 0.1 V or higher and that between $V4$ and GND is 1.4 V or higher when liquid-crystal drives, particularly when the VR is small.

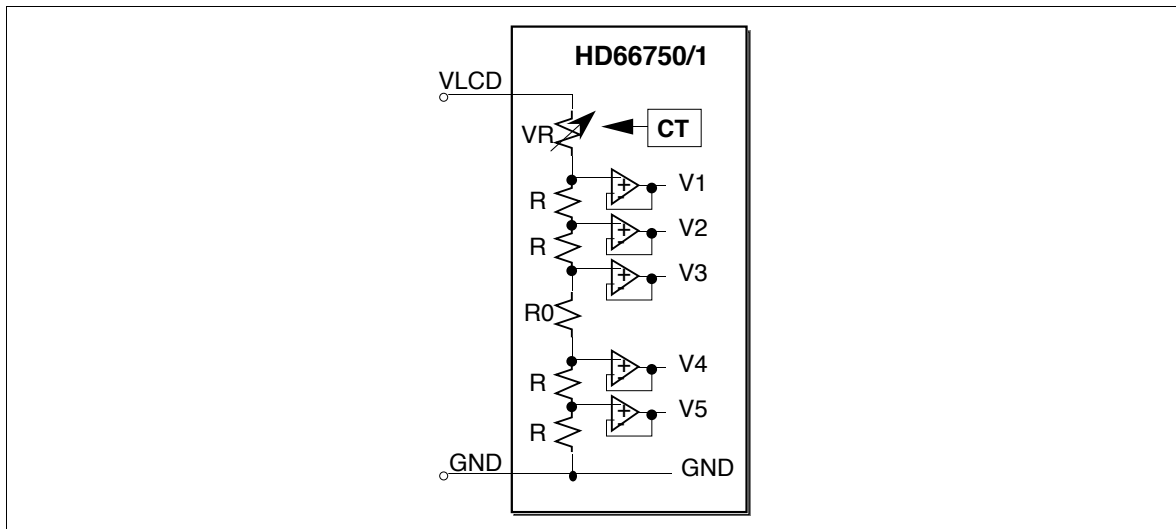

Figure 40 Contrast Adjuster

HD66750/1

Table 20 Contrast Adjustment Bits (CT) and Variable Resistor Values

CT Set Value						Variable Resistor Value (VR)	Potential Difference between V1 and GND	Display Color
CT5	CT4	CT3	CT2	CT1	CT0			
0	0	0	0	0	0	3.20 x R	<div style="display: flex; justify-content: space-between; align-items: center;"> <div style="text-align: center;">(Small)</div> <div style="text-align: center;"> </div> <div style="text-align: center;">(Light)</div> </div> <div style="display: flex; justify-content: space-between; align-items: center; margin-top: 200px;"> <div style="text-align: center;"> </div> <div style="text-align: center;">(Large)</div> <div style="text-align: center;"> </div> <div style="text-align: center;">(Deep)</div> </div>	
0	0	0	0	0	1			
0	0	0	0	1	0			
0	0	0	0	1	1			
0	0	0	1	0	0			
0	0	0	1	0	1			
0	0	0	1	1	0			
0	0	0	1	1	1			
0	0	1	0	0	0			
0	0	1	0	0	1			
0	0	1	0	1	0			
0	0	1	0	1	1			
0	0	1	1	0	0			
⋮								
0	1	1	1	1	1			
1	0	0	0	0	0			
1	0	0	0	0	1			
1	0	0	0	1	0			
1	0	0	0	1	1			
1	0	0	1	0	0			
1	0	0	1	0	1			
1	0	0	1	1	0			
1	0	0	1	1	1			
1	0	1	0	0	0			
1	1	1	0	0	1			
⋮								
1	1	1	1	0	0			
1	1	1	1	0	1			
1	1	1	1	1	0			
1	1	1	1	1	1			

Liquid-crystal-display Drive-bias Selector

An optimum liquid-crystal-display bias value can be selected using the BS2-0 bits, according to the liquid crystal drive duty ratio setting (NL3-0 bits). The liquid-crystal-display drive duty ratio and bias value can be displayed while switching software applications to match the LCD panel display status. The optimum bias value calculated using the following expression is a logical optimum value. Driving by using a lower value than the optimum bias value provides lower logical contrast and lower liquid-crystal-display voltage (the potential difference between V1 and GND), which results in better image quality. When the liquid-crystal-display voltage is insufficient even if a seven-times booster is used, when the boosting driving ability is lowered by setting a high factor for the booster, or when the output voltage is lowered because the battery life has been reached, the display can be made easier to see by lowering the liquid-crystal-display bias.

The liquid crystal display can be adjusted by using the contrast adjustment register (CT5-0 bits) and selecting the booster output level (BT1/0 bits).

$$\text{Optimum bias value for } 1/N \text{ duty ratio drive voltage} = \frac{1}{\sqrt{N+1}}$$

Table 21 Optimum Drive Bias Values

LCD drive duty ratio	1/128	1/120	1/112	1/104	1/96	1/88	1/80	1/72	1/64	1/32	1/24	1/16
(NL3-0 set value)	1111	1110	1101	1100	1011	1010	1001	1000	0111	0100	0011	0010
Optimum drive bias value	1/11	1/11	1/11	1/11	1/10	1/10	1/10	1/9	1/9	1/6	1/6	1/5
(BS2-0 set value)	000	000	000	000	001	001	001	010	010	101	101	100

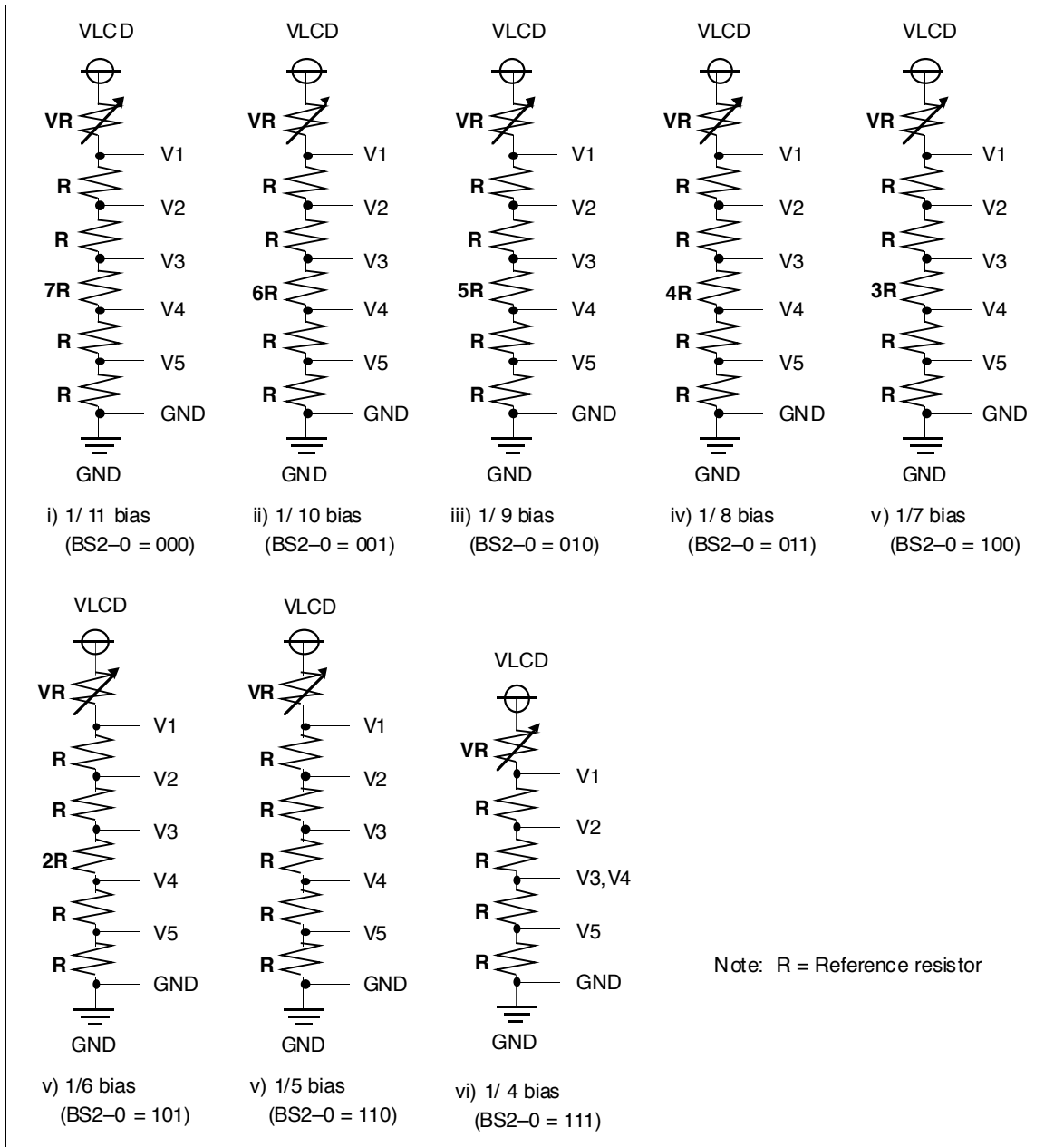

Figure 41 Liquid Crystal Display Drive Bias Circuit

Table 22 Contrast Adjustment per Bias Drive Voltage

Bias	LCD drive voltage: V_{DR}	Contrast adjustment range
1/11 bias drive	$\frac{11 \times R}{11 \times R + VR} \times (V_{LCD} - GND)$	- LCD drive voltage adjustment range : $0.775 \times (V_{LCD}-GND) \leq V_{DR} \leq 0.995 \times (V_{LCD}-GND)$ - Limit of potential difference between V4 and GND : $\frac{2 \times R}{11 \times R + VR} \times (V_{LCD}-GND) \geq 1.4 [V]$ - Limit if potential difference between VLCD and V1 : $\frac{VR}{11 \times R + VR} \times (V_{LCD}-GND) \geq 0.1 [V]$
1/10 bias drive	$\frac{10 \times R}{10 \times R + VR} \times (V_{LCD} - GND)$	- LCD drive voltage adjustment range : $0.757 \times (V_{LCD}-GND) \leq V_{DR} \leq 0.995 \times (V_{LCD}-GND)$ - Limit of potential difference between V4 and GND : $\frac{2 \times R}{10 \times R + VR} \times (V_{LCD}-GND) \geq 1.4 [V]$ - Limit if potential difference between VLCD and V1 : $\frac{VR}{10 \times R + VR} \times (V_{LCD}-GND) \geq 0.1 [V]$
1/9 bias drive	$\frac{9 \times R}{9 \times R + VR} \times (V_{LCD} - GND)$	- LCD drive voltage adjustment range : $0.737 \times (V_{LCD}-GND) \leq V_{DR} \leq 0.994 \times (V_{LCD}-GND)$ - Limit of potential difference between V4 and GND : $\frac{2 \times R}{9 \times R + VR} \times (V_{LCD}-GND) \geq 1.4 [V]$ - Limit if potential difference between VLCD and V1 : $\frac{VR}{9 \times R + VR} \times (V_{LCD}-GND) \geq 0.1 [V]$
1/8 bias drive	$\frac{8 \times R}{8 \times R + VR} \times (V_{LCD} - GND)$	- LCD drive voltage adjustment range : $0.714 \times (V_{LCD}-GND) \leq V_{DR} \leq 0.993 \times (V_{LCD}-GND)$ - Limit of potential difference between V4 and GND : $\frac{2 \times R}{8 \times R + VR} \times (V_{LCD}-GND) \geq 1.4 [V]$ - Limit if potential difference between VLCD and V1 : $\frac{VR}{8 \times R + VR} \times (V_{LCD}-GND) \geq 0.1 [V]$
1/7 bias drive	$\frac{7 \times R}{7 \times R + VR} \times (V_{LCD} - GND)$	- LCD drive voltage adjustment range : $0.686 \times (V_{LCD}-GND) \leq V_{DR} \leq 0.993 \times (V_{LCD}-GND)$ - Limit of potential difference between V4 and GND : $\frac{2 \times R}{7 \times R + VR} \times (V_{LCD}-GND) \geq 1.4 [V]$ - Limit if potential difference between VLCD and V1 : $\frac{VR}{7 \times R + VR} \times (V_{LCD}-GND) \geq 0.1 [V]$
1/6 bias drive	$\frac{6 \times R}{6 \times R + VR} \times (V_{LCD} - GND)$	- LCD drive voltage adjustment range : $0.652 \times (V_{LCD}-GND) \leq V_{DR} \leq 0.992 \times (V_{LCD}-GND)$ - Limit of potential difference between V4 and GND : $\frac{2 \times R}{6 \times R + VR} \times (V_{LCD}-GND) \geq 1.4 [V]$ - Limit if potential difference between VLCD and V1 : $\frac{VR}{6 \times R + VR} \times (V_{LCD}-GND) \geq 0.1 [V]$
1/5 bias drive	$\frac{5 \times R}{5 \times R + VR} \times (V_{LCD} - GND)$	- LCD drive voltage adjustment range : $0.610 \times (V_{LCD}-GND) \leq V_{DR} \leq 0.990 \times (V_{LCD}-GND)$ - Limit of potential difference between V4 and GND : $\frac{2 \times R}{5 \times R + VR} \times (V_{LCD}-GND) \geq 1.4 [V]$ - Limit if potential difference between VLCD and V1 : $\frac{VR}{5 \times R + VR} \times (V_{LCD}-GND) \geq 0.1 [V]$
1/4 bias drive	$\frac{4 \times R}{4 \times R + VR} \times (V_{LCD} - GND)$	- LCD drive voltage adjustment range : $0.556 \times (V_{LCD}-GND) \leq V_{DR} \leq 0.988 \times (V_{LCD}-GND)$ - Limit of potential difference between V4 and GND : $\frac{2 \times R}{4 \times R + VR} \times (V_{LCD}-GND) \geq 1.4 [V]$ - Limit if potential difference between VLCD and V1 : $\frac{VR}{4 \times R + VR} \times (V_{LCD}-GND) \geq 0.1 [V]$

HD66750/1

Four-grayscale Display Function

The HD66750/1 supports the four-grayscale monochrome display function. The four-grayscale monochrome display is used for the display data of the two-bit pixel set sent to the CGRAM. There are four grayscale levels: always unlit, weak middle level, strong middle level, and always lit. In the weak middle-level grayscale display, the GS bit can select the 1/3 or 1/2 level.

The frame rate control (FRC) method is used for grayscale control.

Table 23 Relationships between the CGRAM Data and the Display Contents

Upper Bit	Lower Bit	Liquid Crystal Display
0	0	Non-selected (unlit)
0	1	GS = 0: 1/3-level grayscale (one frame lit during a three-frame period) GS = 1: 1/2-level grayscale (one frame lit during a two-frame period)
1	0	2/3-level grayscale (two frames lit during a three-frame period)
1	1	Selected (lit)

Note: Upper bits: DB15, DB13, DB11, DB9, DB7, DB5, DB3, and DB1
Lower bits: DB14, DB12, DB10, DB8, DB6, DB4, DB2, and DB0

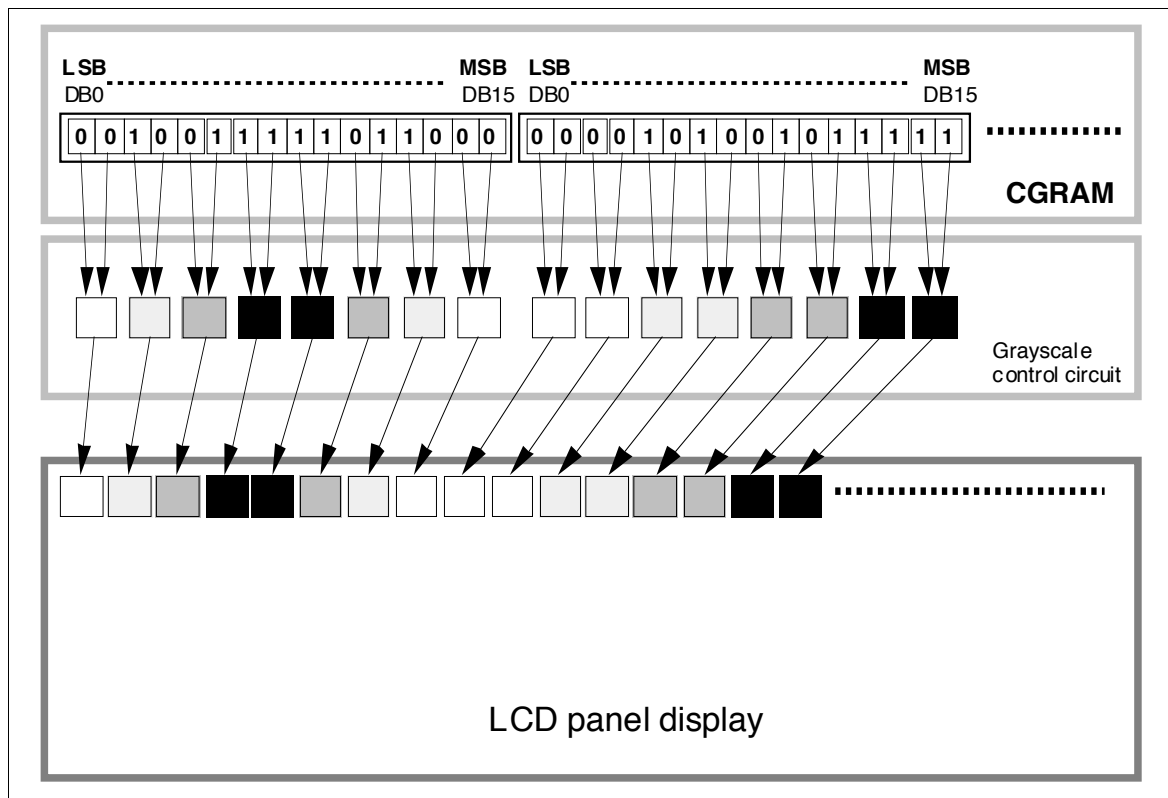

Figure 42 Four-grayscale Monochrome Display

Window Cursor Display Function

The HD66750/1 displays the window cursor by specifying a window area. The horizontal display position of the window cursor is specified with the horizontal cursor position register (HS6-0 to HE6-0), and the vertical display position is specified with the vertical cursor position register (VS6-0 or VE6-0). In these display position setting registers, ensure that $HS6-0 \leq HE6-0$ and $VS6-0 \leq VE6-0$. If these relationships are not satisfied, normal display cannot be attained. In addition, if the setting is $VS6-0 = VE6-0 = 00H$, a cursor is displayed on a raster-row at the most-upper edge of the screen.

This window cursor can automatically display the hardware-supported block cursor, highlight window, or menu bar. The CM1-0 bits select the following four displays in each window cursor:

1. White-blink cursor (CM1-0 = 00): Alternately blinks between the normal display and an all-white (unlit) display
2. Black-blink cursor (CM1-0 = 01): Alternately blinks between the normal display and an all-black (all lit) display
3. Black-and-white reversed cursor (CM1-0 = 10): Black-and-white-reversed normal display (no blinking)
4. Black-and-white-reversed blink cursor (CM1-0 = 11): Alternately blinks between the normal display and a black-and-white-reversed display

The above blinking display is switched in a 32-frame unit.

In vertical scrolling, note that this window cursor does not automatically move vertically.

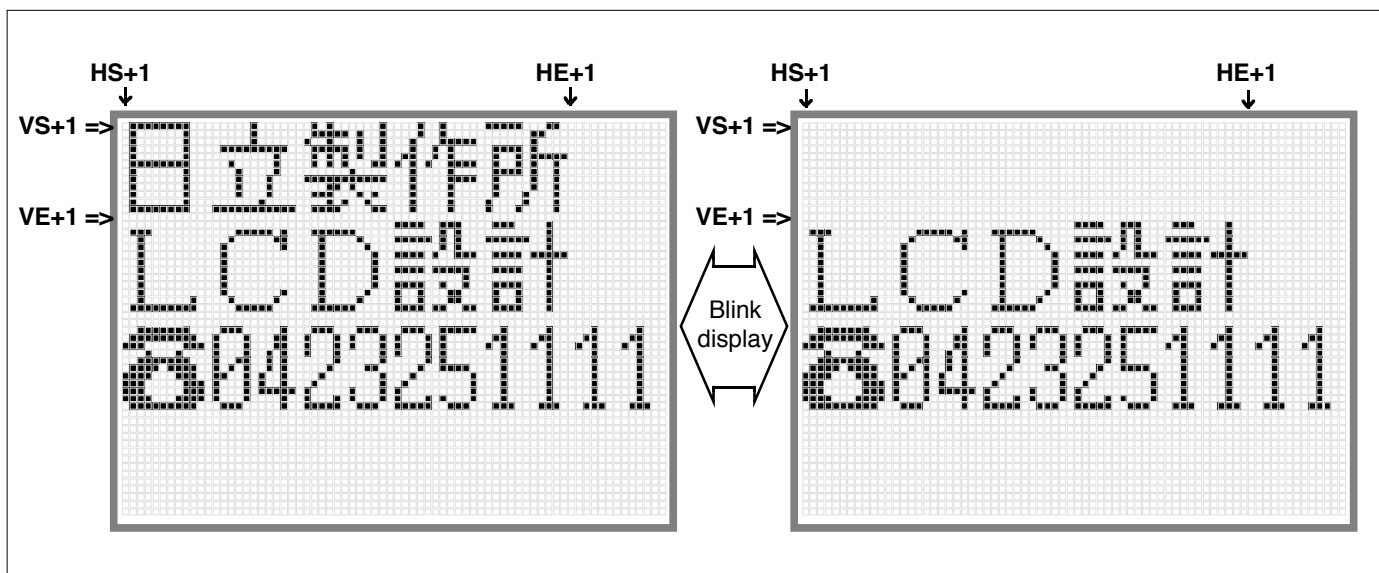

Figure 43 White Blink Cursor Display

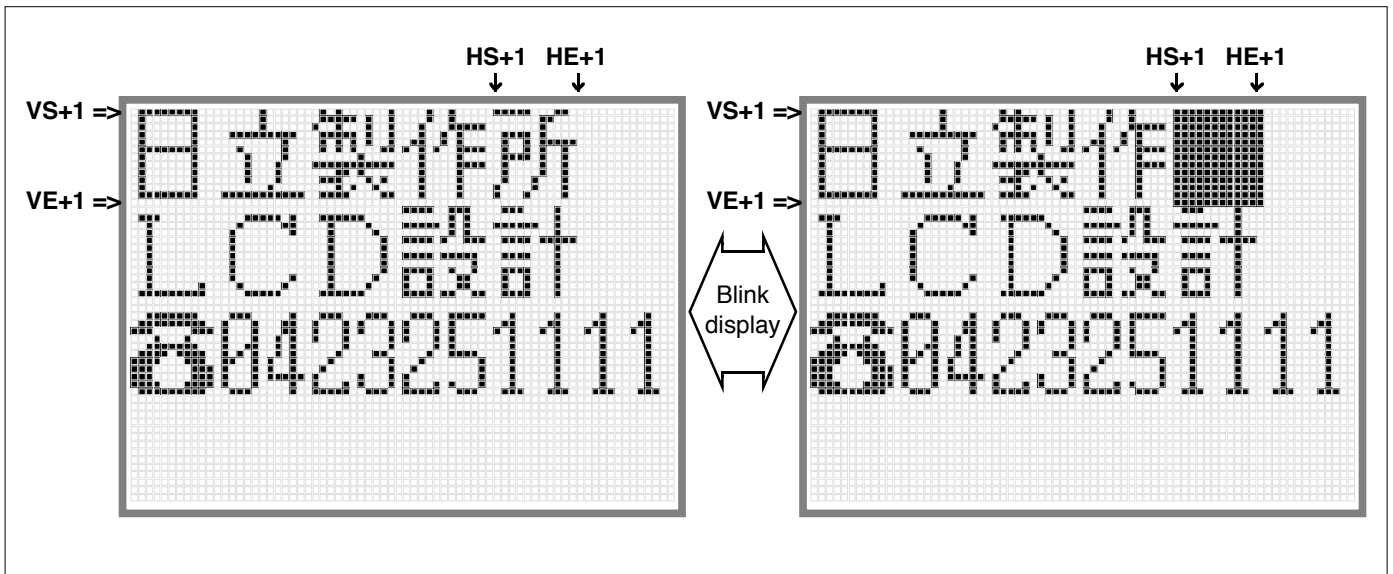

Figure 44 Black Blink Cursor Display

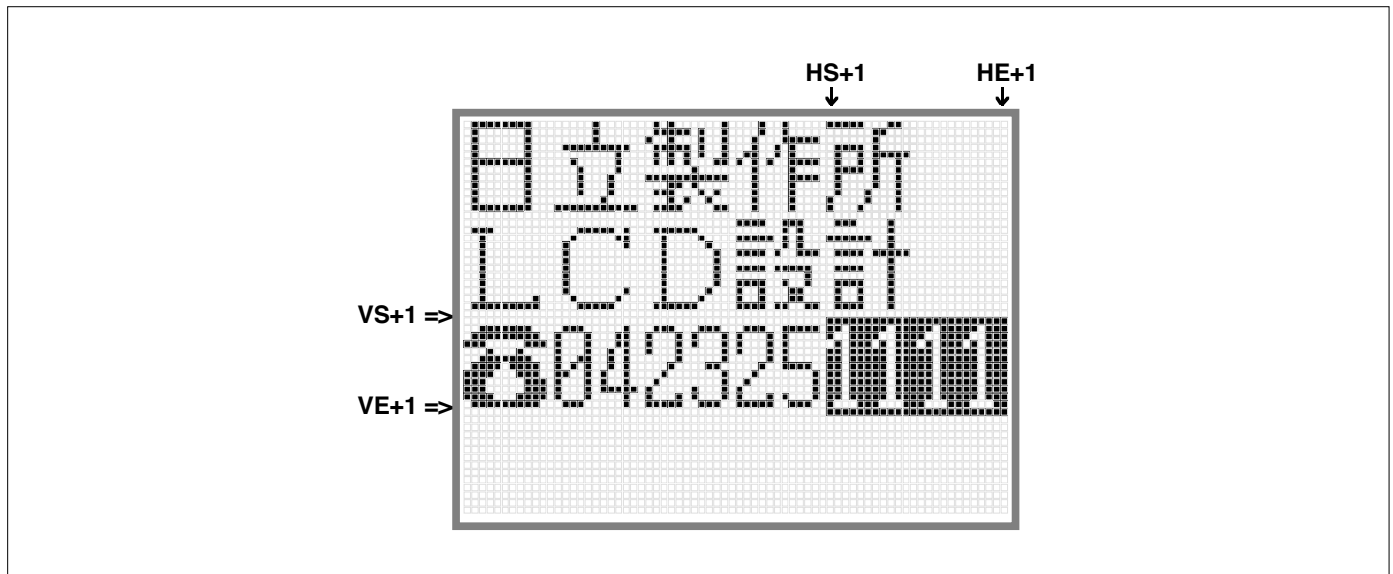

Figure 45 Black-and-white Reversed Cursor Display

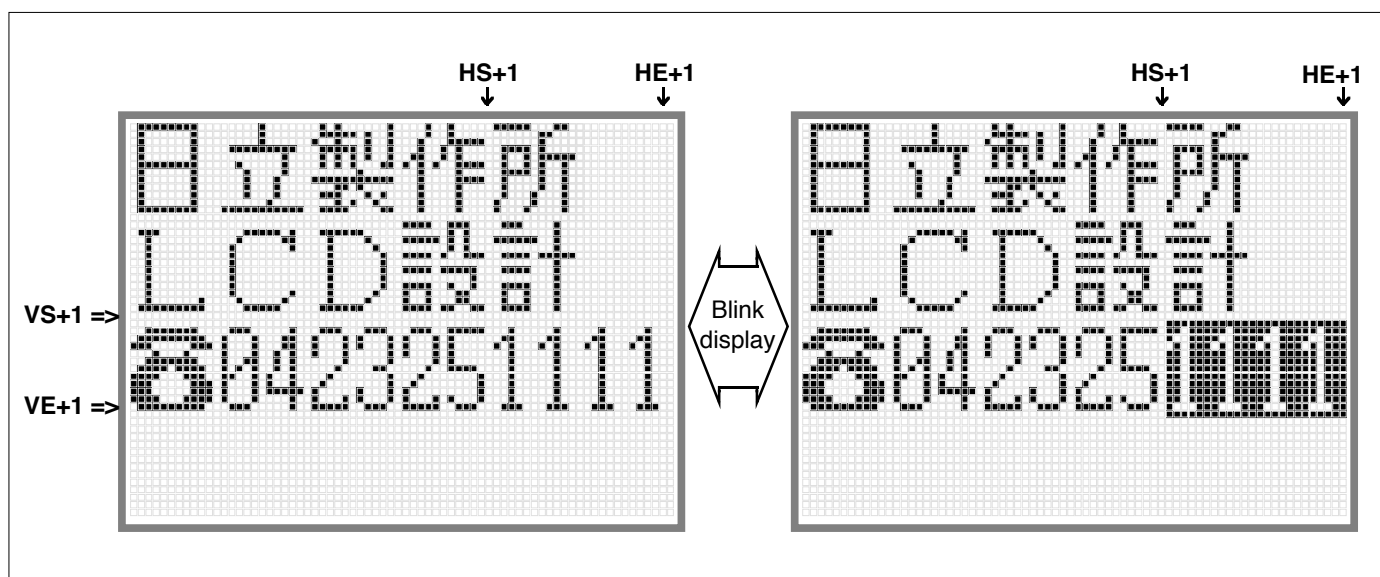

Figure 46 Black-and-white Reversed Blink Cursor Display

HD66750/1

Vertical Smooth Scroll Display

The HD66750/1 can scroll the graphics display vertically in units of raster-rows. The data storage capacity of the CGRAM is 128 raster-rows. Continuous smooth vertical scrolling is achieved by writing display data into a raster-row area that is not being used for display. After the 128th raster-row is displayed, the first raster-row is displayed again. Using the status read, the user can check the display raster-rows (L6-0) that are currently driving the LCD, and flicker can be eliminated by writing the display data in the CGRAM while the LCD is not driven.

Additionally, when display areas of a graphics icon such as a pictogram or a menu bar are partially fixed-displayed, the remaining areas can be displayed. For details, see the Partial Smooth Scroll Display Function section.

Specifically, this function is controlled by incrementing or decrementing the value in the display-start raster-row bits (SL6-0) by 1. For example, to smoothly scroll up, increment display-start raster-row bits (SL6-0) by 1 from 0000000 to 1111111 to scroll 128 raster-rows.

Note that the vertical double-height display or window cursor display is not automatically changed in synchronization with the vertical scrolling.

When the response speed of the liquid crystal is low or when high-speed scrolling is needed, two- to four-raster-row scrolling is recommended.

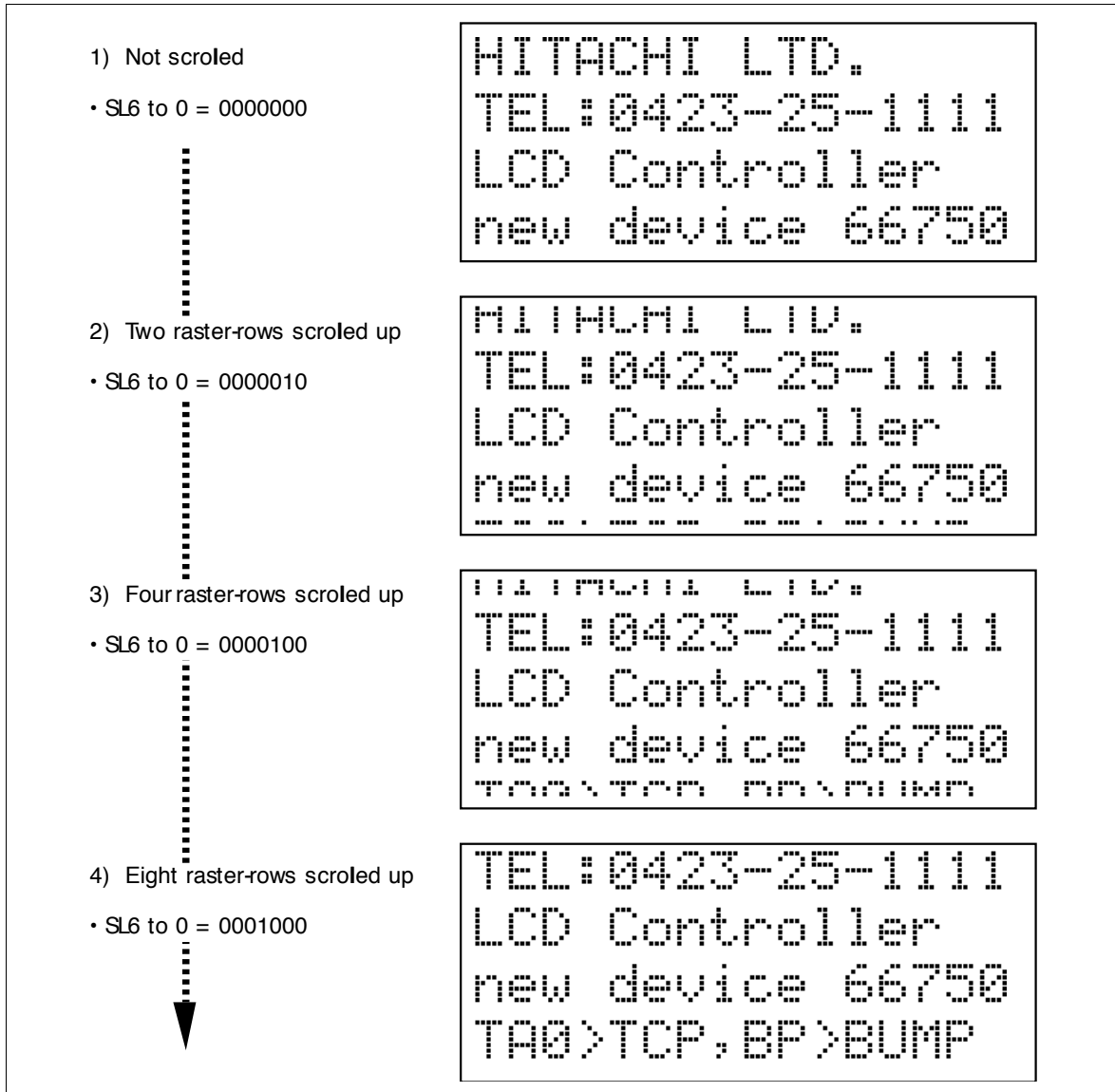

Figure 47 Vertical Smooth Scroll

HD66750/1

Partial Smooth Scroll Display Function

The HD66750/1 can partially fixed-display the areas of a graphics icon such as a pictogram or a menu bar, and perform vertical smooth scrolling of the remaining bit-map areas. Since the PS1 to PS0 bits are not used for smooth scrolling of the upper first to 24th display raster-rows but are used for fixed-display, pictograms can be placed on the screen. This function can largely control the rewrite frequencies of the bit-map data during smooth scrolling and reduce the software load of the MPU.

Table 24 Bit Setting and Display Lines

Bit Setting	COM Position	SL6 to 0 = 00H	SL6 to 0 = 01H	SL6 to 0 = 02H	SL6 to 0 = 04H	SL6 to 0 = 07H	SL6 to 0 = 08H	SL6 to 0 = 7EH	SL6 to 0 = 7FH
		PS1 to 0 = 00	COM1 ↓ COM120	1st raster-row 2nd raster-row 3rd raster-row ⋮ 119th raster-row 120th raster-row	2nd raster-row 3rd raster-row 4th raster-row ⋮ 120th raster-row 121th raster-row	3rd raster-row 4th raster-row 5th raster-row ⋮ 121th raster-row 122th raster-row	5th raster-row 6th raster-row 7th raster-row ⋮ 123th raster-row 124th raster-row	8th raster-row 9th raster-row 10th raster-row ⋮ 126th raster-row 127th raster-row	9th raster-row 10th raster-row 11th raster-row ⋮ 127th raster-row 128th raster-row
PS1 to 0 = 01	COM1 ↓ COM120	1st to 8th raster-rows 1st raster-row 2nd raster-row 3rd raster-row 4th raster-row ⋮ 110th raster-row 111th raster-row 112th raster-row	1st to 8th raster-rows 2nd raster-row 3rd raster-row 4th raster-row 5th raster-row ⋮ 111th raster-row 112th raster-row 113th raster-row	1st to 8th raster-rows 3rd raster-row 4th raster-row 5th raster-row 6th raster-row ⋮ 112th raster-row 113th raster-row 114th raster-row	1st to 8th raster-rows 5th raster-row 6th raster-row 7th raster-row 8th raster-row ⋮ 114th raster-row 115th raster-row 116th raster-row	1st to 8th raster-rows 8th raster-row 9th raster-row 10th raster-row 11th raster-row ⋮ 117th raster-row 118th raster-row 119th raster-row	1st to 8th raster-rows 9th raster-row 10th raster-row 11th raster-row 12th raster-row ⋮ 118th raster-row 119th raster-row 120th raster-row	1st to 8th raster-rows 127th raster-row 128th raster-row 9th raster-row 10th raster-row ⋮ 116th raster-row 117th raster-row 118th raster-row	1st to 8th raster-rows 128th raster-row 9th raster-row 10th raster-row 11th raster-row ⋮ 117th raster-row 118th raster-row 119th raster-row
PS1 to 0 = 10	COM1 ↓ COM120	1st to 16th raster-rows 1st raster-row 2nd raster-row 3rd raster-row ⋮ 102th raster-row 103th raster-row 104th raster-row	1st to 16th raster-rows 2nd raster-row 3rd raster-row 4th raster-row ⋮ 103th raster-row 104th raster-row 105th raster-row	1st to 16th raster-rows 3rd raster-row 4th raster-row 5th raster-row ⋮ 104th raster-row 105th raster-row 106th raster-row	1st to 16th raster-rows 5th raster-row 6th raster-row 7th raster-row ⋮ 106th raster-row 107th raster-row 108th raster-row	1st to 16th raster-rows 8th raster-row 9th raster-row 10th raster-row ⋮ 109th raster-row 110th raster-row 111th raster-row	1st to 16th raster-rows 9th raster-row 10th raster-row 11th raster-row ⋮ 110th raster-row 111th raster-row 112th raster-row	1st to 16th raster-rows 127th raster-row 128th raster-row 17th raster-row 18th raster-row ⋮ 116th raster-row 117th raster-row 118th raster-row	1st to 16th raster-rows 128th raster-row 17th raster-row 18th raster-row ⋮ 117th raster-row 118th raster-row 119th raster-row
PS1 to 0 = 11	COM1 ↓ COM120	1st to 24th raster-rows 1st raster-row 2nd raster-row 3rd raster-row ⋮ 94th raster-row 95th raster-row 96th raster-row	1st to 24th raster-rows 2nd raster-row 3rd raster-row 4th raster-row ⋮ 95th raster-row 96th raster-row 97th raster-row	1st to 24th raster-rows 3rd raster-row 4th raster-row 5th raster-row ⋮ 96th raster-row 97th raster-row 98th raster-row	1st to 24th raster-rows 5th raster-row 6th raster-row 7th raster-row ⋮ 98th raster-row 99th raster-row 100th raster-row	1st to 24th raster-rows 8th raster-row 9th raster-row 10th raster-row ⋮ 101th raster-row 102th raster-row 103th raster-row	1st to 24th raster-rows 9th raster-row 10th raster-row 11th raster-row ⋮ 102th raster-row 103th raster-row 104th raster-row	1st to 24th raster-rows 127th raster-row 128th raster-row 25th raster-row 26th raster-row ⋮ 118th raster-row 119th raster-row	1st to 24th raster-rows 128th raster-row 25th raster-row 26th raster-row ⋮ 117th raster-row 118th raster-row 119th raster-row

- Notes: 1. The shadow raster-rows above are fixed-displayed. They do not depend on the setting values of the SL6 to 0 bits.
 2. The SL6 to 0 bits specify the next first scroll display raster-row of the fixed-displayed raster-rows.

Partial Smooth Scroll Display Examples

Table 25 Data Setting to the CGRAM

CGRAM Address	CGRAM Data
000 to 07F	
080 to 0FF	HITACHI LTD Semi
100 to 17F	conductor
180 to 1FF	Kodaira
200 to 27F	Tokyo
280 to 2FF	Japan
300 to 37F	T187
380 to 3FF	TEL: 0423-25-1111
400 to 47F	TEL: 0762-20-1111
480 to 4FF	
500 to 57F	
580 to 5FF	

i) Initial Screen Display

- PS1 to 0 = 01: Fixed-displays the first to eighth raster-rows
- SL6 to 0 = 0001000: Starts display from the ninth raster-row

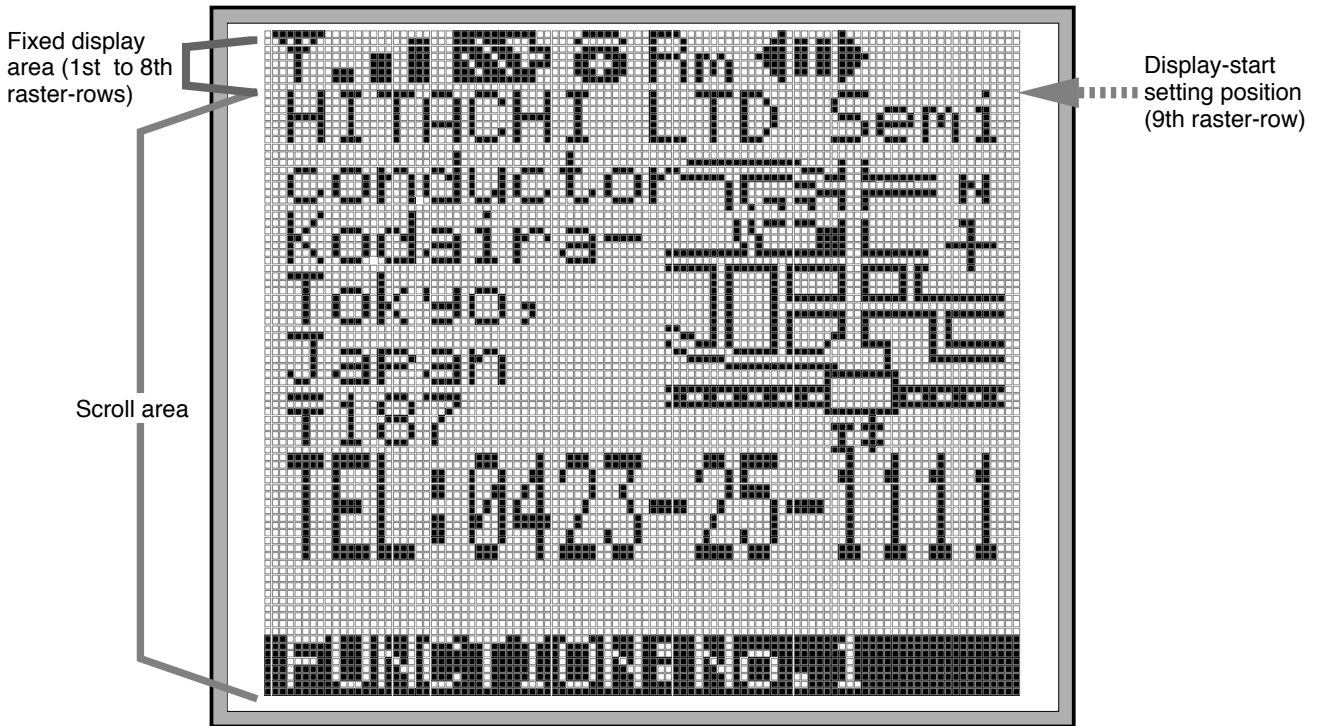

Figure 48 Example of Initial Screen in the Partial Smooth Scroll Mode

ii) Four-dot Partial Scroll Up

- PS1 to 0 = 01: Fixed-displays the first to eighth raster-rows
- SL6 to 0 = 0001100: Starts display from the 13th raster-row



Figure 49 Example of Display Screen in the Partial Smooth Scroll Mode (1)

iii) Eight-dot Partial Scroll Up

- PS1 to 0 = 01: Fixed-displays the first to eighth raster-rows
- SL6 to 0 = 0010000: Starts display from the 17th raster-row

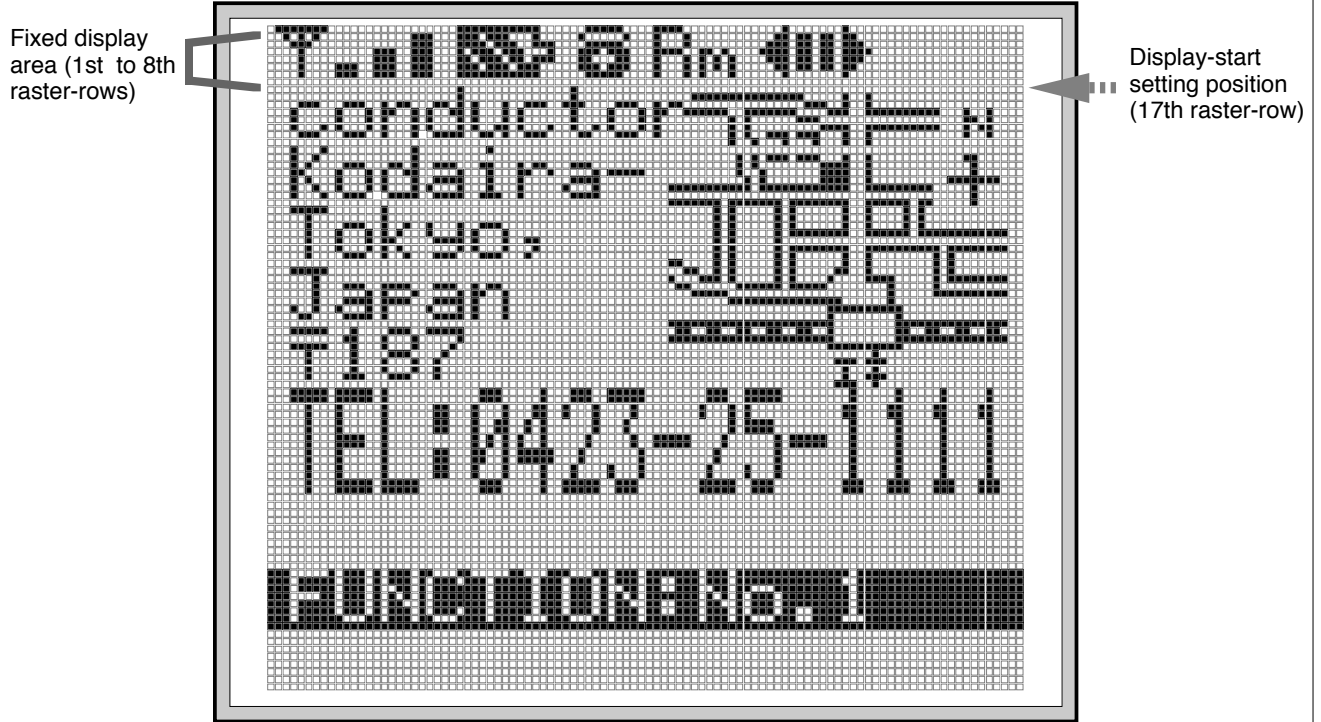

Figure 50 Example of Display Screen in the Partial Smooth Scroll Mode (2)

Double-height Display Function

The HD66750/1 can double the height of any desired area in units of raster-rows (dots). The double-height display is done by setting the DHE bit in the display control register to 1.

The start position of the double-height display is set by the DS6 to DS0 bits of the double-height display position register, and the double-height display starts at the (the setting value plus one)-th raster-row. The end position is set by the DE6 to DE0 bits of the double-height display position register, and the display ends at the (the setting value plus one)-th raster-row. Here, the end position of the double-height display must be after the start position, so set the register setting values so that

$DS6-0 \leq DE6-0$. When the area specified to be doubled in height is an odd number of raster-rows, the double-height display is done up to the (DE6-0 plus one)-th raster-row.

In vertical smooth scrolling, the double-height display position does not automatically move up or down.

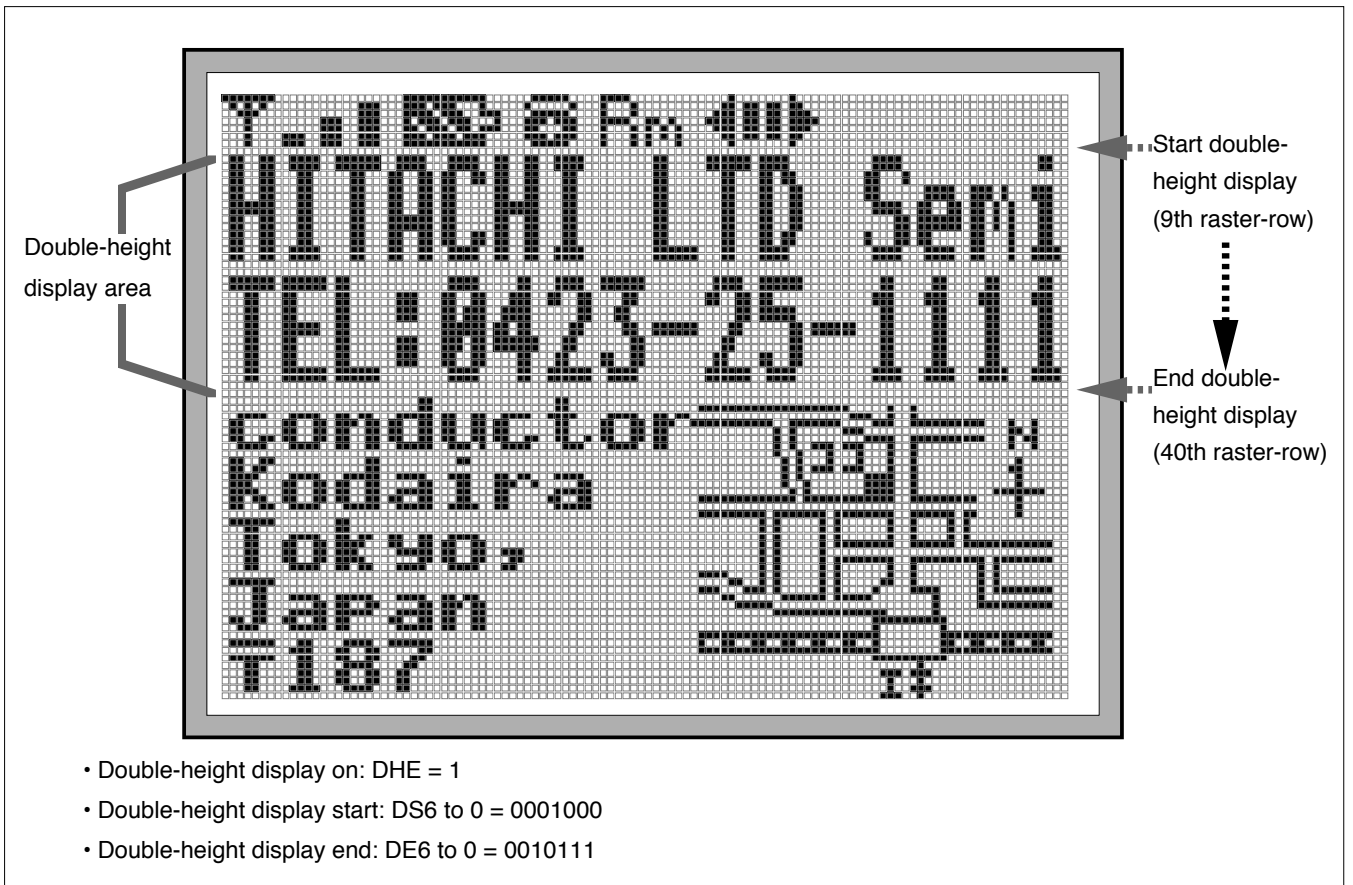
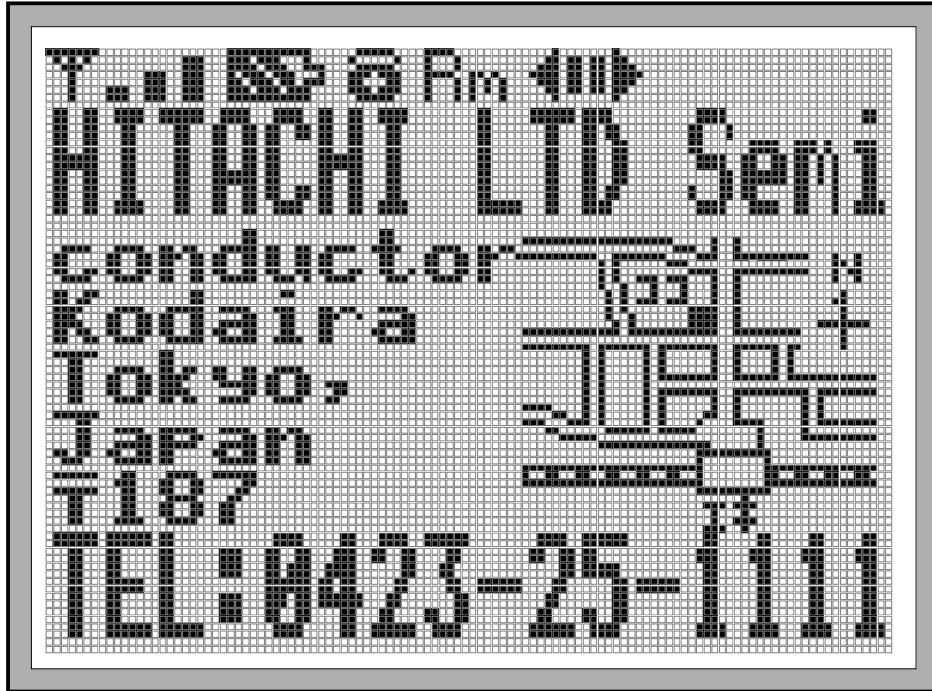

Figure 51 Double-height Display (9th to 40th raster-rows)

Reversed Display Function

The HD66750/1 can display graphics display sections by black-and-white reversal. Black-and-white reversal can be easily displayed when the REV bit in the display control register is set to 1.



REV = 1 (Reversed display)

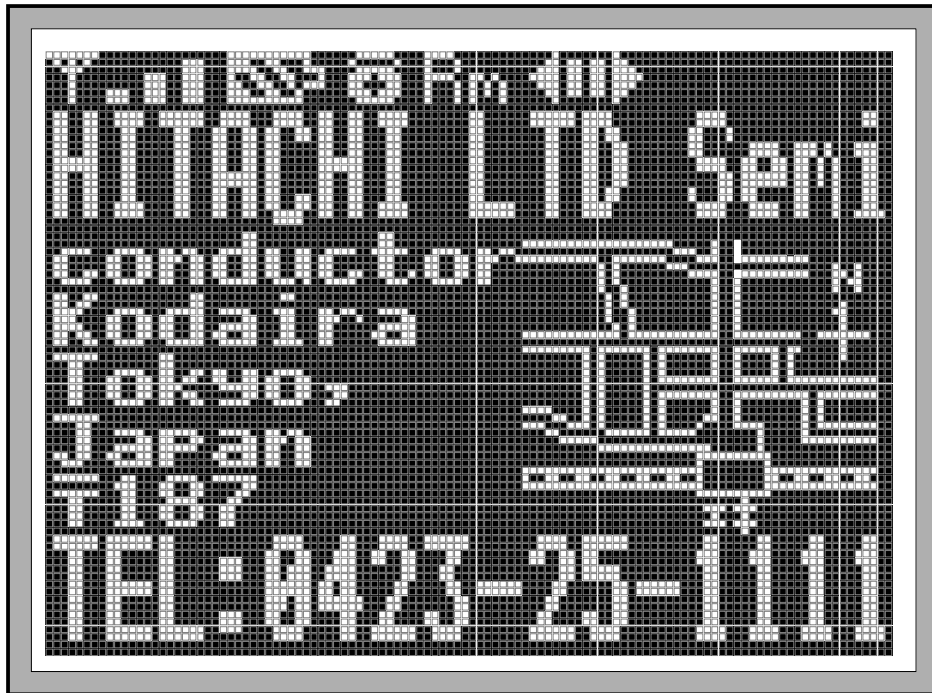

Figure 52 Reversed Display

Partial-display-on Function

The HD66750/1 can program the liquid crystal display drive duty ratio setting (NL3-0 bits), the liquid crystal display drive bias value selection (BS2-0 bits), the boost output level selection (BT1-0 bits), and the contrast adjustment (CT5-0 bits). For example, when the 128 x 120-dot screen is normally displayed with a 1/120 duty ratio, the HD66750/1 can selectively drive only the center of the screen or the top of the screen by combining these register functions and the centering display function (CN bit). This is called partial-display-on. Lowering the liquid crystal display drive duty ratio reduces the liquid crystal display drive voltage, thus reducing internal current consumption. This is suitable for a 16 raster-row display (1/16 duty ratio) of a calendar or time in the system-standby state, or the display of only graphics icons (pictograms) at the top of the screen, which enables continuous display with minimal current consumption. The non-displayed lines are constantly driven by the unselected level voltage, thus turning off the LCD for these lines.

In general, lowering the liquid crystal display drive duty ratio decreases the optimum liquid crystal display drive voltage and liquid crystal display drive bias value. This reduces output multiplying factors in the booster and greatly controls consumption current.

Table 26 Partial-display-on Function (1/120-duty Normal Drive)

Item	Normal Display	Partial-on Display (Limited to Four-line Display)	
LCD screen	128 x 120 dots	128 x 16 dots only on the center of the screen	128 x 16 dots only at the top of the screen
LCD drive position shift	Not necessary (CN = 0)	Necessary (CN = 1)	Not necessary (CN = 0)
LCD drive duty ratio	1/120 (NL3 to 0 = 1110)	1/16 (NL3 to 0 = 0001)	1/16 (NL3 to 0 = 0001)
LCD drive bias value (optimum)	1/11 (BS2 to 0 = 000)	1/5 (BS2 to 0 = 110)	1/5 (BS2 to 0 = 110)
LCD drive voltage*	13.5 V to 15.5 V (precisely adjustable using CT5 to 0)	4 V to 5 V (precisely adjustable using CT5 to 0)	4 V to 5 V (precisely adjustable using CT5 to 0)
Boosting output multiplying factor	Six times (BT1 to 0 = 10)	Two times (BT1 to 0 = 00)	Two times (BT1 to 0 = 00)
Frame frequency (fosc = 70 kHz)	68 Hz	68 Hz	68 Hz

Note: The LCD drive voltage depends on the LCD materials used. Since the LCD drive voltage is high when the LCD drive duty ratio is high, a low duty ratio enables low-power consumption.

i) 1/16-duty Drive at the Top of the Screen



Figure 53 Partial-on Display (Date and Time Indicated) (1)

ii) 1/16-duty Drive at the Center of the Screen (Centering Display)

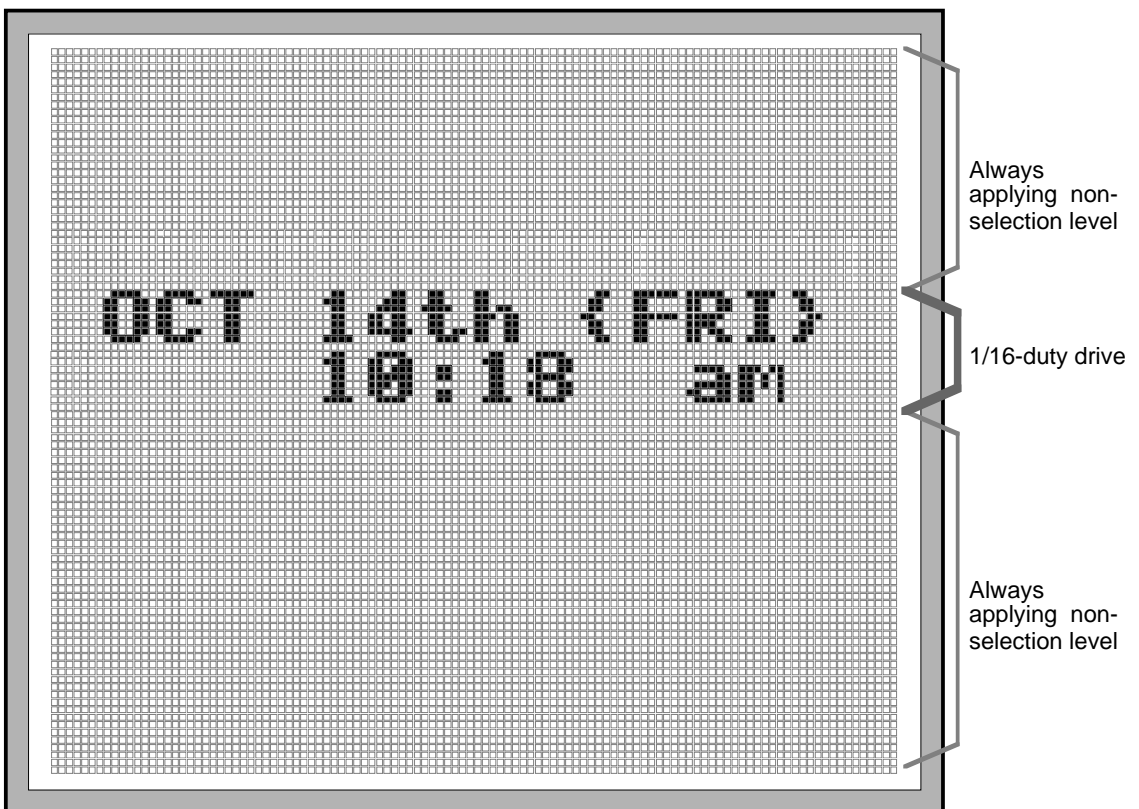

Figure 54 Partial-on Display (Date and Time Indicated) (2)

Sleep Mode

Setting the sleep mode bit (SLP) to 1 puts the HD66750/1 in the sleep mode, where the device stops all internal display operations, thus reducing current consumption. Specifically, LCD operation is completely halted. Here, all the SEG (SEG1 to SEG128) and COM (COM1 to COM128) pins output the GND level, resulting in no display. If the AP1-0 bits in the power control register are set to 00 in the sleep mode, the LCD drive power supply can be turned off, reducing the total current consumption of the LCD module.

Table 27 Comparison of Sleep Mode and Standby Mode

Function	Sleep Mode (SLP = 1)	Standby Mode (STB = 1)
LCD control	Turned off	Turned off
R-C oscillation circuit	Operates normally	Operation stopped

Standby Mode

Setting the standby mode bit (STB) to 1 puts the HD66750/1 in the standby mode, where the device stops completely, halting all internal operations including the R-C oscillation circuit, thus further reducing current consumption compared to that in the sleep mode. Specifically, all the SEG (SEG1 to SEG128) and COM (COM1 to COM128) pins for the multiplexing drive output the GND level, resulting in no display. If the AP1-0 bits are set to 00 in the standby mode, the LCD drive power supply can be turned off.

During the standby mode, no instructions can be accepted other than the start-oscillation instruction. To cancel the standby mode, issue the start-oscillation instruction to stabilize R-C oscillation before setting the STB bit to 0.

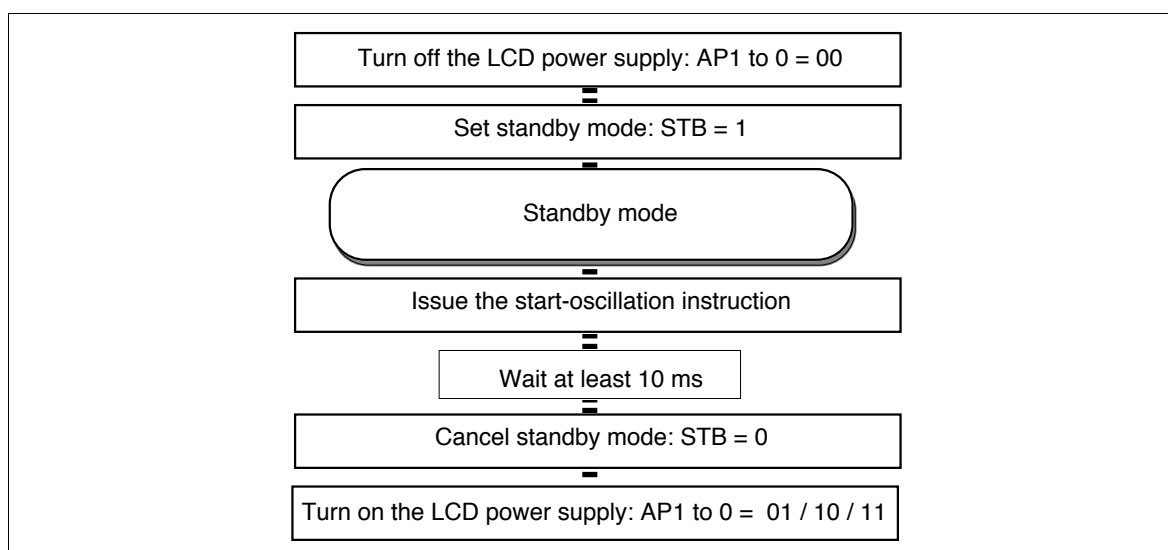

Figure 55 Procedure for Setting and Canceling Standby Mode

HD66750/1

Absolute Maximum Ratings

Item	Symbol	Unit	Value	Notes*
Power supply voltage (1)	V_{CC}	V	-0.3 to +4.6	1, 2
Power supply voltage (2)	$V_{LCD} - GND$	V	-0.3 to +16.5	1, 3
Input voltage	V_t	V	-0.3 to $V_{CC} + 0.3$	1
Operating temperature	T_{opr}	°C	-40 to +85	1, 4
Storage temperature	T_{stg}	°C	-55 to +110	1, 5

Notes: 1. If the LSI is used above these absolute maximum ratings, it may become permanently damaged. Using the LSI within the following electrical characteristics limits is strongly recommended for normal operation. If these electrical characteristic conditions are also exceeded, the LSI will malfunction and cause poor reliability.

2. $V_{CC} > GND$ must be maintained.
3. $V_{LCD} > GND$ must be maintained.
4. For bare die and wafer products, specified up to 85°C.
5. This temperature specifications apply to the TCP package.

DC Characteristics ($V_{CC} = 1.8$ to 3.6 V, $T_a = -40$ to $+85^\circ\text{C}^{*1}$)

Item	Symbol	Min	Typ	Max	Unit	Test Condition	Notes
Input high voltage	V_{IH}	$0.7 V_{CC}$	—	V_{CC}	V		2, 3
Input low voltage	V_{IL}	−0.3	—	$0.15 V_{CC}$	V	$V_{CC} = 1.8$ to 2.4 V	2, 3
		−0.3	—	$0.15 V_{CC}$	V	$V_{CC} = 2.4$ to 3.6 V	2, 3
Output high voltage (1) (DB0-15 pins)	V_{OH1}	$0.75 V_{CC}$	—	—	V	$I_{OH} = -0.1$ mA	2
Output low voltage (1) (DB0-15 pins)	V_{OL1}	—	—	$0.2 V_{CC}$	V	$V_{CC} = 1.8$ to 2.4 V, $I_{OL} = 0.1$ mA	2
		—	—	$0.15 V_{CC}$	V	$V_{CC} = 2.4$ to 3.6 V, $I_{OL} = 0.1$ mA	2
Driver ON resistance (COM pins)	R_{COM}	—	3	10	k Ω	$\pm I_d = 0.05$ mA, $V_{LCD} = 10$ V	4
Driver ON resistance (SEG pins)	R_{SEG}	—	3	10	k Ω	$\pm I_d = 0.05$ mA, $V_{LCD} = 10$ V	4
I/O leakage current	I_{Li}	−1	—	1	μA	$V_{in} = 0$ to V_{CC}	5
Current consumption during normal operation ($V_{CC} - \text{GND}$)	I_{OP}	—	50 (T.B.D.)	90 (T.B.D.)	μA	R-C oscillation, $V_{CC} = 3$ V, $T_a = 25^\circ\text{C}$, f_{OSC} $= 70$ kHz (1/120 duty)	6, 7
Current consumption during sleep mode ($V_{CC} - \text{GND}$)	I_{SL}	—	10	—	μA	R-C oscillation, $V_{CC} = 3$ V, $T_a = 25^\circ\text{C}$, f_{OSC} $= 70$ kHz (1/120 duty)	6, 7
Current consumption during standby mode ($V_{CC} - \text{GND}$)	I_{ST}	—	0.1	5	μA	$V_{CC} = 3$ V, $T_a = 25^\circ\text{C}$	6, 7
LCD drive power supply current ($V_{LCD} - \text{GND}$)	I_{LCD}	—	25 (T.B.D.)	40 (T.B.D.)	μA	$V_{LCD} = 15$ V, 1/11 bias, $T_a = 25^\circ\text{C}$, $f_{OSC} = 70$ kHz	7
LCD drive voltage ($V_{LCD} - \text{GND}$)	V_{LCD}	5.0	—	15.5	V		8

Note: For the numbered notes, refer to the Electrical Characteristics Notes section following these tables.

HD66750/1

Booster Characteristics (T. B. D.)

Item	Symbol	Min	Typ	Max	Unit	Test Condition	Notes
Two-times-boost output voltage (VLOUT pin)	V_{UP2}	3.9	4.3	4.4	V	$V_{CC} = V_{ci} = 2.2\text{ V}$, $I_o = 30\ \mu\text{A}$, $C = 1\ \mu\text{F}$, $f_{OSC} = 70\ \text{kHz}$, $T_a = 25^\circ\text{C}$	11
Five-times-boost output voltage (VLOUT pin)	V_{UP5}	10.5	10.8	11.0	V	$V_{CC} = V_{ci} = 2.2\text{ V}$, $I_o = 30\ \mu\text{A}$, $C = 1\ \mu\text{F}$, $f_{OSC} = 70\ \text{kHz}$, $T_a = 25^\circ\text{C}$	11
Six-times-boost output voltage (VLOUT pin)	V_{UP6}	12.7	12.9	13.2	V	$V_{CC} = V_{ci} = 2.2\text{ V}$, $I_o = 30\ \mu\text{A}$, $C = 1\ \mu\text{F}$, $f_{OSC} = 70\ \text{kHz}$, $T_a = 25^\circ\text{C}$	11
Seven-times-boost output voltage (VLOUT pin)	V_{UP7}	13.9	15.1	15.4	V	$V_{CC} = V_{ci} = 2.2\text{ V}$, $I_o = 30\ \mu\text{A}$, $C = 1\ \mu\text{F}$, $f_{OSC} = 70\ \text{kHz}$, $T_a = 25^\circ\text{C}$	11
Use range of boost output voltages	V_{UP2} V_{UP5} V_{UP6} V_{UP7}	V_{CC}	—	15.5	V	For two- to seven-times boost	11

Note: For the numbered notes, refer to the Electrical Characteristics Notes section following these tables.

AC Characteristics ($V_{CC} = 1.8$ to 3.6 V, $T_a = -40$ to $+85^\circ\text{C}^{*1}$)
Clock Characteristics ($V_{CC} = 1.8$ to 3.6 V)

Item	Symbol	Min	Typ	Max	Unit	Test Condition	Notes
External clock frequency	f _{cp}	50	75	150	kHz		9
External clock duty ratio	Duty	45	50	55	%		9
External clock rise time	tr _{cp}	—	—	0.2	μs		9
External clock fall time	tf _{cp}	—	—	0.2	μs		9
R-C oscillation clock	f _{osc}	59	74	89	kHz	R _f = 390 kΩ, V _{CC} = 3 V	10

Note: For the numbered notes, refer to the Electrical Characteristics Notes section following these tables.

68-system Bus Interface Timing Characteristics
(V_{CC} = 1.8 to 2.4 V)

Item	Symbol	Min	Typ	Max	Unit	Test Condition
Enable cycle time	Write t _{CYCE}	600	—	—	ns	Figure 62
	Read t _{CYCE}	800	—	—		
Enable high-level pulse width	Write PW _{EH}	120	—	—	ns	Figure 62
	Read PW _{EH}	350	—	—		
Enable low-level pulse width	Write PW _{EL}	300	—	—	ns	Figure 62
	Read PW _{EL}	300	—	—		
Enable rise/fall time	t _{Er} , t _{Ef}	—	—	25	ns	Figure 62
Setup time (RS, R/W to E, CS*)	t _{ASE}	50	—	—	ns	Figure 62
Address hold time	t _{AHE}	20	—	—	ns	Figure 62
Write data setup time	t _{DSWE}	60	—	—	ns	Figure 62
Write data hold time	t _{HE}	20	—	—	ns	Figure 62
Read data delay time	t _{DDRE}	—	—	300	ns	Figure 62
Read data hold time	t _{DHRE}	5	—	—	ns	Figure 62

HD66750/1

(V_{CC} = 2.4 to 3.6 V)

Item	Symbol	Min	Typ	Max	Unit	Test Condition
Enable cycle time	Write t_{CYCE}	380	—	—	ns	Figure 62
	Read t_{CYCE}	500	—	—		
Enable high-level pulse width	Write PW_{EH}	70	—	—	ns	Figure 62
	Read PW_{EH}	250	—	—		
Enable low-level pulse width	Write PW_{EL}	150	—	—	ns	Figure 62
	Read PW_{EL}	150	—	—		
Enable rise/fall time	t_{Er}, t_{Ef}	—	—	25	ns	Figure 62
Setup time (RS, R/W to E, CS*)	t_{ASE}	50	—	—	ns	Figure 62
Address hold time	t_{AHE}	20	—	—	ns	Figure 62
Write data setup time	t_{DSWE}	60	—	—	ns	Figure 62
Write data hold time	t_{HE}	20	—	—	ns	Figure 62
Read data delay time	t_{DDRE}	—	—	200	ns	Figure 62
Read data hold time	t_{DHRE}	5	—	—	ns	Figure 62

80-system Bus Interface Timing Characteristics
(V_{CC} = 1.8 to 2.4 V)

Item	Symbol	Min	Typ	Max	Unit	Test Condition
Bus cycle time	Write t_{CYCW}	600	—	—	ns	Figure 63
	Read t_{CYCR}	800	—	—	ns	Figure 63
Write low-level pulse width	PW_{LW}	120	—	—	ns	Figure 63
Read low-level pulse width	PW_{LR}	350	—	—	ns	Figure 63
Write high-level pulse width	PW_{HW}	300	—	—	ns	Figure 63
Read high-level pulse width	PW_{HR}	300	—	—	ns	Figure 63
Write/Read rise/fall time	$t_{WRr, WRf}$	—	—	25	ns	Figure 63
Setup time (RS to CS*, WR*, RD*)	t_{AS}	50	—	—	ns	Figure 63
Address hold time	t_{AH}	20	—	—	ns	Figure 63
Write data setup time	t_{DSW}	60	—	—	ns	Figure 63
Write data hold time	t_H	20	—	—	ns	Figure 63
Read data delay time	t_{DDR}	—	—	300	ns	Figure 63
Read data hold time	t_{DHR}	5	—	—	ns	Figure 63

(V_{CC} = 2.4 to 3.6 V)

Item	Symbol	Min	Typ	Max	Unit	Test Condition
Bus cycle time	Write t_{CYCW}	380	—	—	ns	Figure 63
	Read t_{CYCR}	500	—	—	ns	Figure 63
Write low-level pulse width	PW_{LW}	70	—	—	ns	Figure 63
Read low-level pulse width	PW_{LR}	250	—	—	ns	Figure 63
Write high-level pulse width	PW_{HW}	150	—	—	ns	Figure 63
Read high-level pulse width	PW_{HR}	150	—	—	ns	Figure 63
Write/Read rise/fall time	$t_{WRr, WRf}$	—	—	25	ns	Figure 63
Setup time (RS to CS*, WR*, RD*)	t_{AS}	50	—	—	ns	Figure 63
Address hold time	t_{AH}	20	—	—	ns	Figure 63
Write data setup time	t_{DSW}	60	—	—	ns	Figure 63
Write data hold time	t_H	20	—	—	ns	Figure 63
Read data delay time	t_{DDR}	—	—	200	ns	Figure 63
Read data hold time	t_{DHR}	5	—	—	ns	Figure 63

Reset Timing Characteristics (V_{CC} = 1.8 to 3.6 V)

Item	Symbol	Min	Typ	Max	Unit	Test Condition
Reset low-level width	t_{RES}	1	—	—	ms	Figure 64

Electrical Characteristics Notes

1. For bare die products, specified up to 85°C.
2. The following three circuits are I/O pin configurations (figure 56).

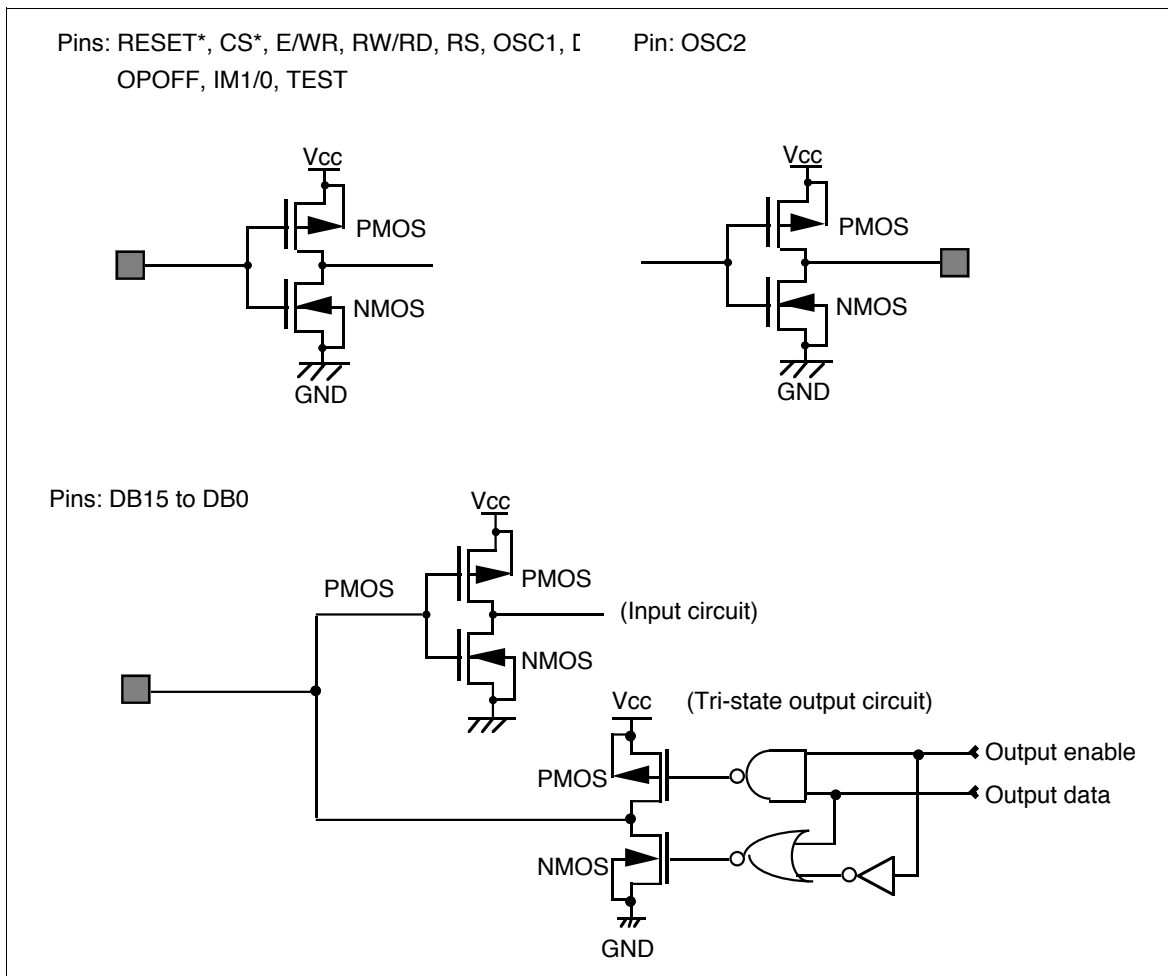
**Figure 56 I/O Pin Configuration**

3. The TEST pin must be grounded and the IM1/0 and OPOFF pins must be grounded or connected to Vcc.
4. Applies to the resistor value (RCOM) between power supply pins V1OUT, V2OUT, V5OUT, GND and common signal pins, and resistor value (RSEG) between power supply pins V1OUT, V3OUT, V4OUT, GND and segment signal pins.
5. This excludes the current flowing through output drive MOSs.
6. This excludes the current flowing through the input/output units. The input level must be fixed high or low because through current increases if the CMOS input is left floating.
7. The following shows the relationship between the operation frequency (fosc) and current consumption (Icc) (figure 57).

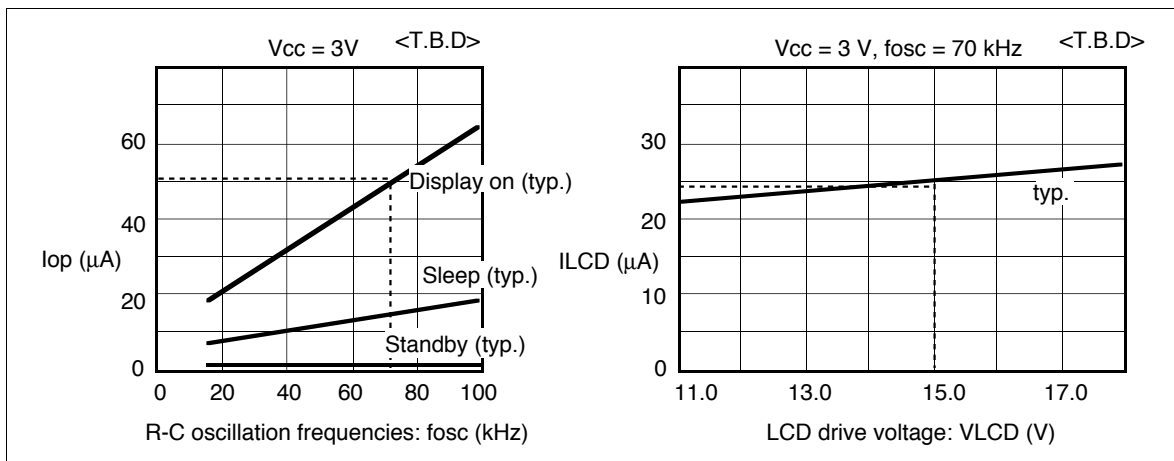

Figure 57 Relationship between the Operation Frequency and Current Consumption

8. Each COM and SEG output voltage is within ±0.15 V of the LCD voltage (Vcc, V1, V2, V3, V4, V5) when there is no load.
9. Applies to the external clock input (figure 58).

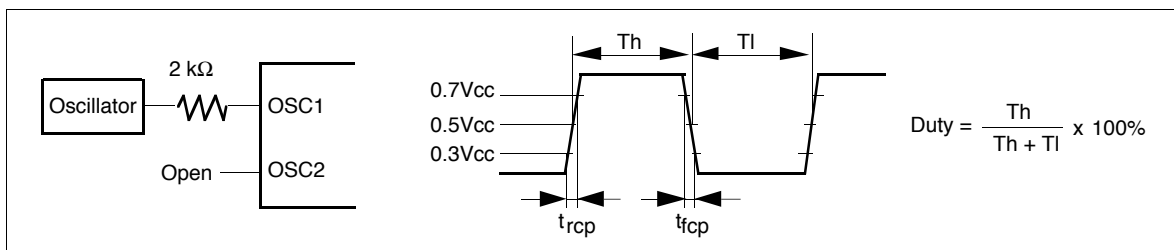

Figure 58 External Clock Supply

HD66750/1

10. Applies to the internal oscillator operations using external oscillation resistor R_f (figure 59 and table 28).

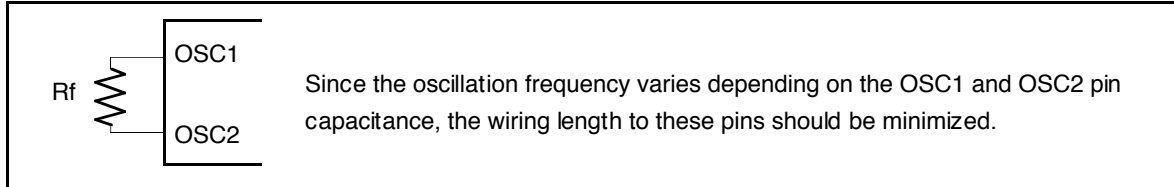

Figure 59 Internal Oscillation

Table 28 External Resistance Value and R-C Oscillation Frequency (Referential Data)

External Resistance (R_f)	R-C Oscillation Frequency: f_{osc}			
	$V_{cc} = 1.8\text{ V}$	$V_{cc} = 2.2\text{ V}$	$V_{cc} = 3.0\text{ V}$	$V_{cc} = 4.0\text{ V}$
200 k Ω	86 kHz	111 kHz	130 kHz	140 kHz
270 k Ω	70 kHz	86 kHz	100 kHz	108 kHz
300 k Ω	64 kHz	79 kHz	92 kHz	98 kHz
330 k Ω	60 kHz	74 kHz	86 kHz	91 kHz
360 k Ω	57 kHz	69 kHz	79 kHz	84 kHz
390 k Ω	54 kHz	64 kHz	74 kHz	78 kHz
430 k Ω	49 kHz	59 kHz	67 kHz	71 kHz
470 k Ω	46 kHz	54 kHz	61 kHz	65 kHz

11. Booster characteristics test circuits are shown in figure 60.

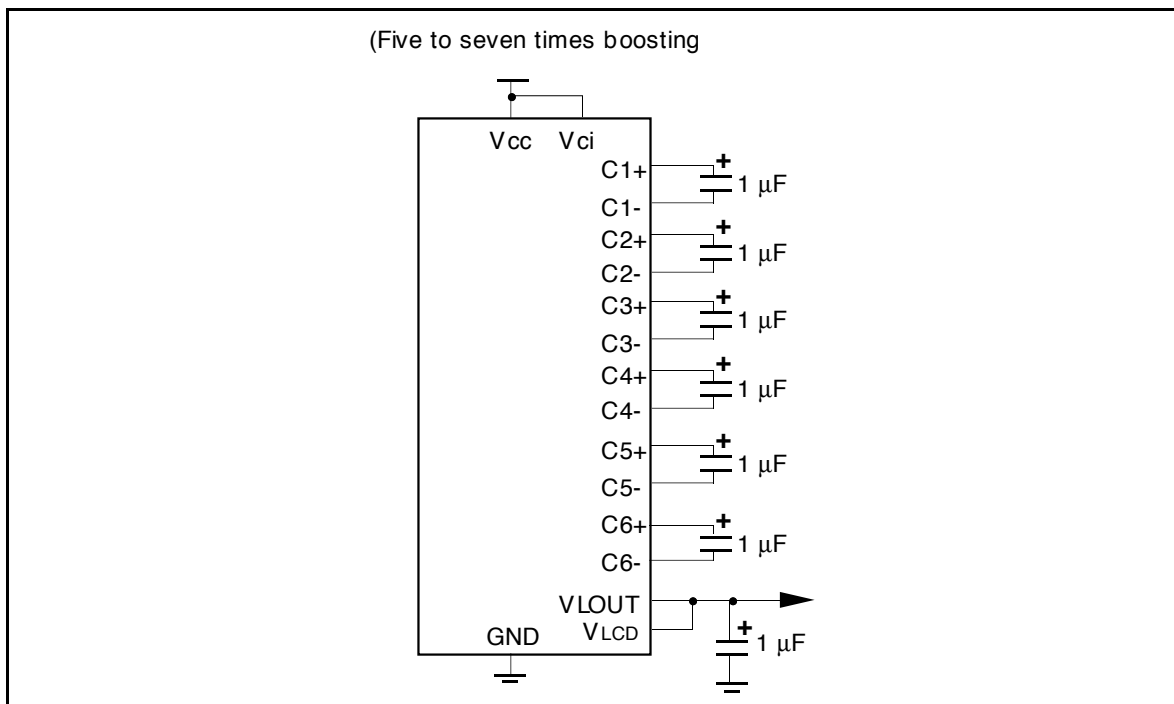
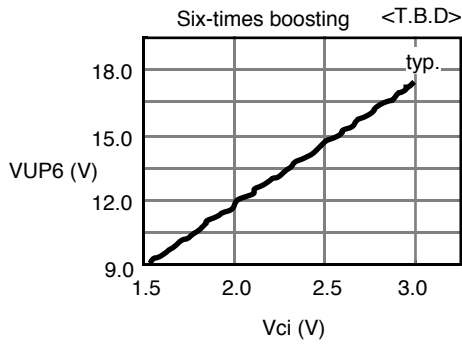

Figure 60 Booster

Referential data

VUP6 = VLCD - GND, VUP7 = VLCD - GND

(i) Relation between the obtained voltage and input voltage



Vci = Vcc, fosc = 70 kHz, Ta = 25°C, DC1 to 0 = 00

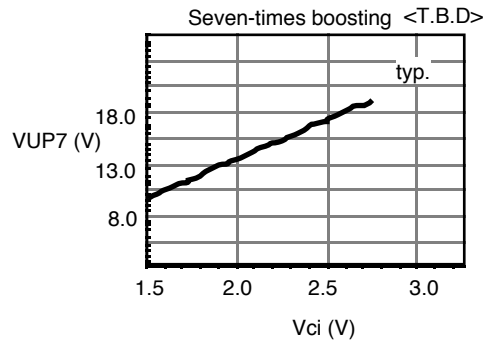

Vci = Vcc, fosc = 70 kHz, Ta = 25°C, DC1 to 0 = 00

(ii) Relation between the obtained voltage and temperature

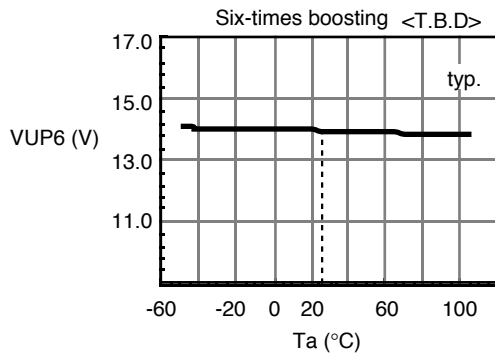

Vci = Vcc = 2.4 V, fosc = 70 kHz, Io = 30 μA, DC1 to 0 = 00

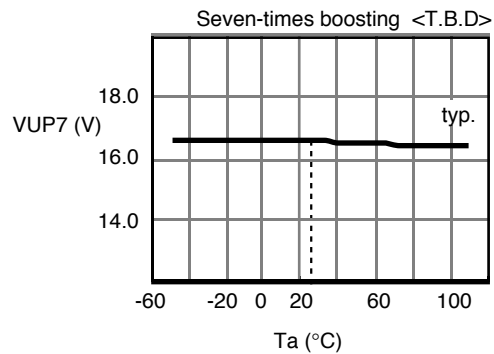

Vci = Vcc = 2.4 V, fosc = 70 kHz, Io = 30 μA, DC1 to 0 = 00

(iii) Relation between the obtained voltage and capacity

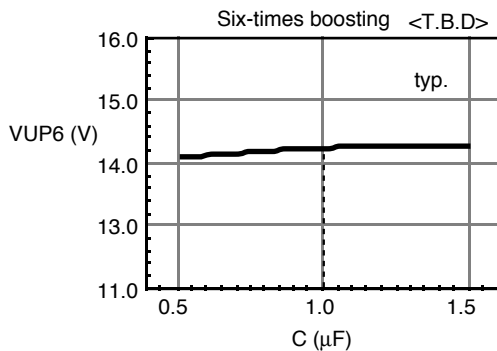

Vci = Vcc = 2.4 V, fosc = 70 kHz, Io = 30 μA, DC1 to 0 = 00

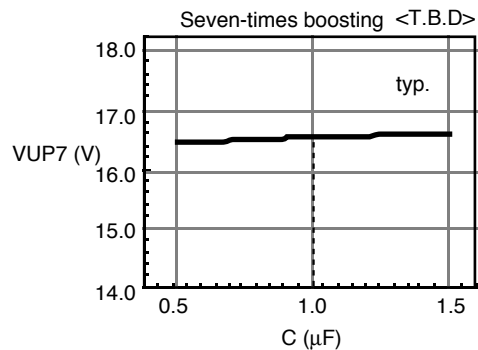

Vci = Vcc = 2.4 V, fosc = 70 kHz, Io = 30 μA, DC1 to 0 = 00

Figure 60 Booster (cont)

(iv) Relation between the obtained voltage and current

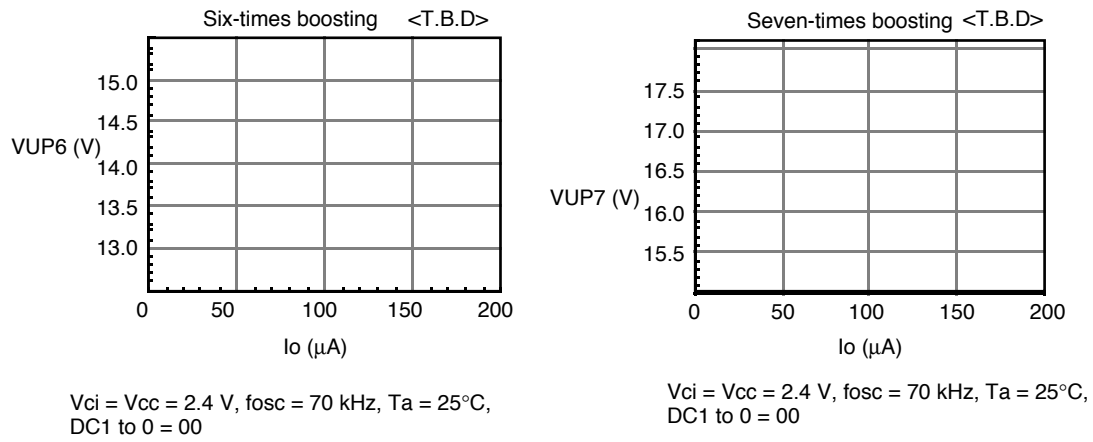

Figure 60 Booster (cont)

Load Circuits

AC Characteristics Test Load Circuits

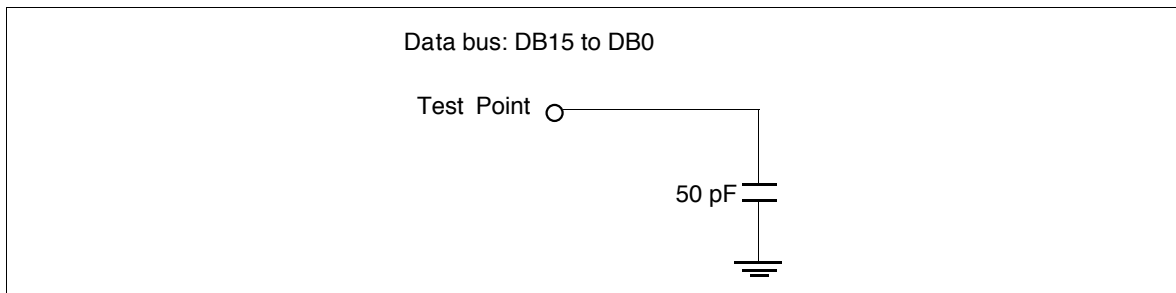

Figure 61 Load Circuit

Timing Characteristics

68-system Bus Operation

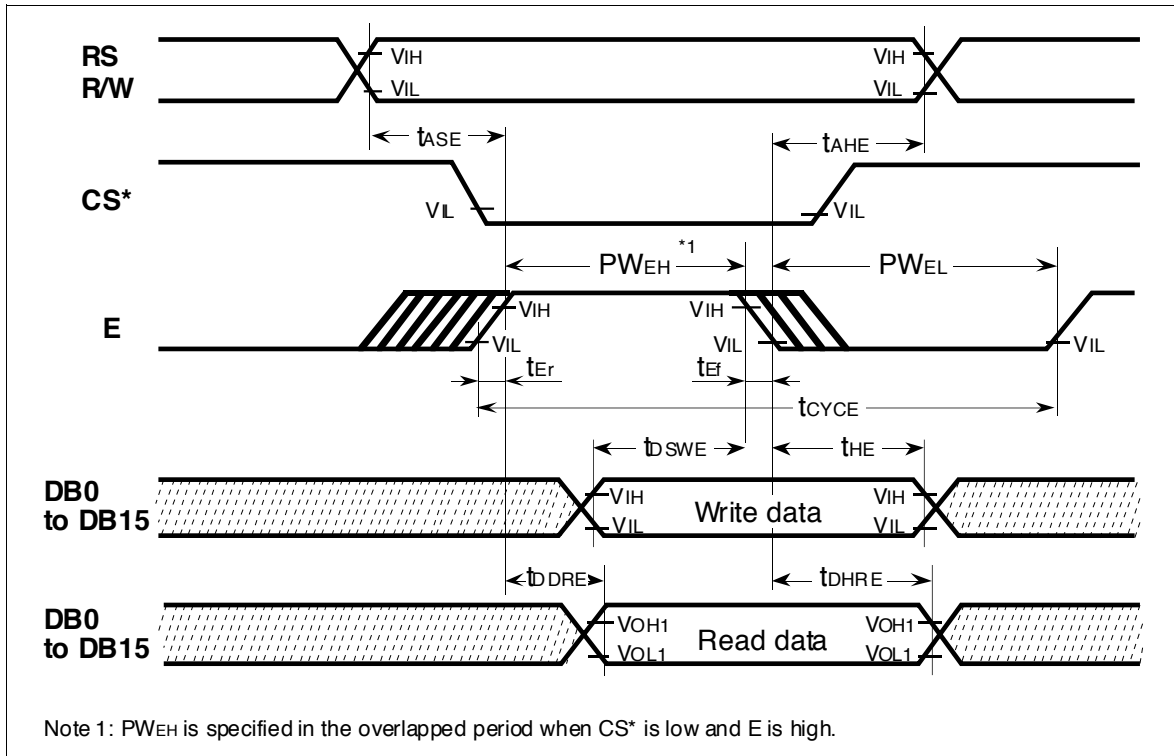

Figure 62 68-system Bus Timing

HD66750/1

80-system Bus Operation

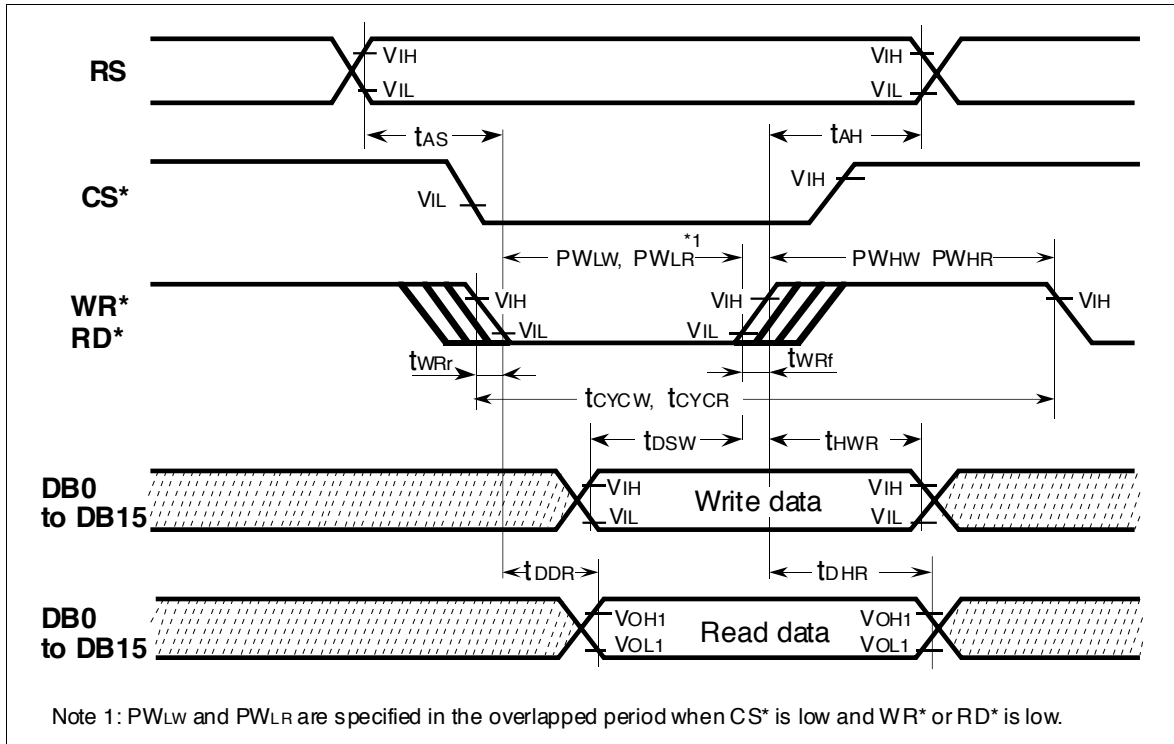

Figure 63 80-system Bus Timing

Reset Operation

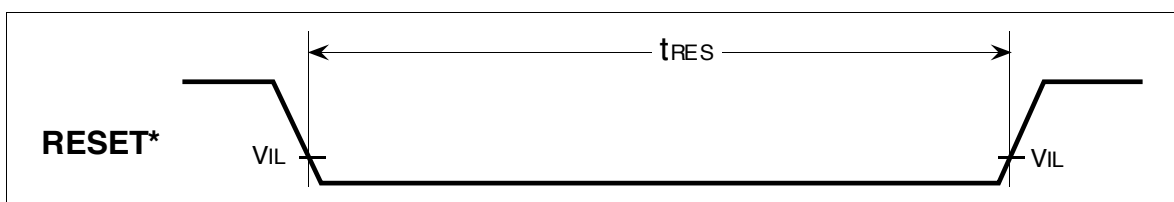

Figure 64 Reset Timing

When using this document, keep the following in mind:

1. This document may, wholly or partially, be subject to change without notice.
2. All right reserved: No one is permitted to reproduce or duplicated, in any form, the whole or part of this document without Hitachi's permission.
3. Hitachi will not be held responsible for any damage to the user that may result from accidents or any other reasons during operation of the user's unit according to this document.
4. Circuitry and other examples described herein are meant merely to indicate the characteristics and performance of Hitachi's semiconductor products. Hitachi assumes no responsibility for any intellectual property claims or other problems that may result from applications based on the examples described herein.
5. No license is granted by implication or otherwise under any patents or other rights of any third party of Hitachi, Ltd.
6. **MEDICAL APPLICATIONS:** Hitachi's products are not authorized for use in **MEDICAL APPLICATIONS** without the written consent of the appropriate officer of Hitachi's sales company. Such use includes, but is not limited to use in life support systems. Buyers of Hitachi's products are requested to notify the relevant Hitachi sales offices when planning to use the products in **MEDICAL APPLICATIONS**.