

Analog Multiplexers/Demultiplexers

The MC14067 and MC14097 multiplexers/demultiplexers are digitally controlled analog switches featuring low ON resistance and very low leakage current. These devices can be used in either digital or analog applications.

The MC14067 is a 16-channel multiplexer/demultiplexer with an inhibit and four binary control inputs A, B, C, and D. These control inputs select 1-of-16 channels by turning ON the appropriate analog switch (see MC14067 truth table.)

The MC14097 is a differential 8-channel multiplexer/demultiplexer with an inhibit and three binary control inputs A, B, and C. These control inputs select 1 of 8 pairs of channels by turning ON the appropriate analog switches (see MC14097 truth table).

- Low OFF Leakage Current
- Matched Channel Resistance
- Low Quiescent Power Consumption
- Low Crosstalk Between Channels
- Wide Operating Voltage Range: 3 to 18 V
- Low Noise
- Pin for Pin Replacement for CD4067B and CD4097B

MC14067B MC14097B

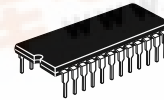

L SUFFIX
CERAMIC
CASE 623

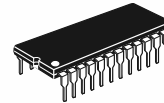

P SUFFIX
PLASTIC
CASE 709

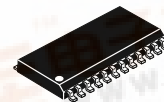

DW SUFFIX
SOIC
CASE 751E

ORDERING INFORMATION

MC14XXXBCP	Plastic
MC14XXXBCL	Ceramic
MC14XXXBDW	SOIC

T_A = - 55° to 125°C for all packages.

MC14067B
16-Channel Analog
Multiplexer/Demultiplexer

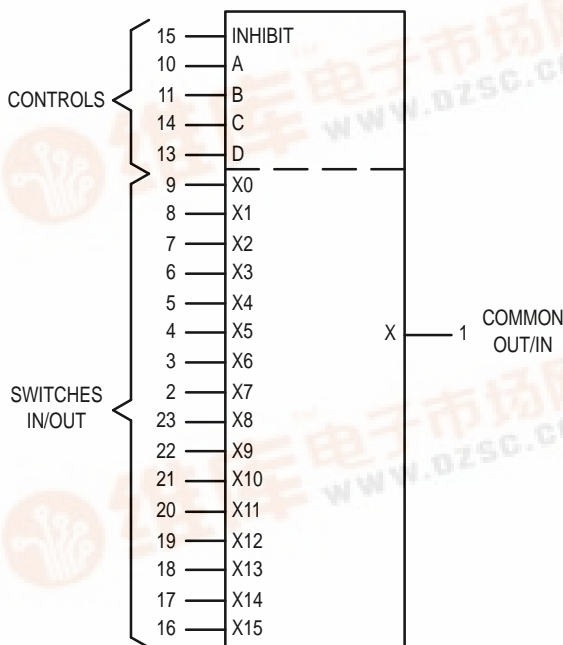

V_{DD} = PIN 24
V_{SS} = PIN 12

MC14097B
Dual 8-Channel Analog
Multiplexer/Demultiplexer

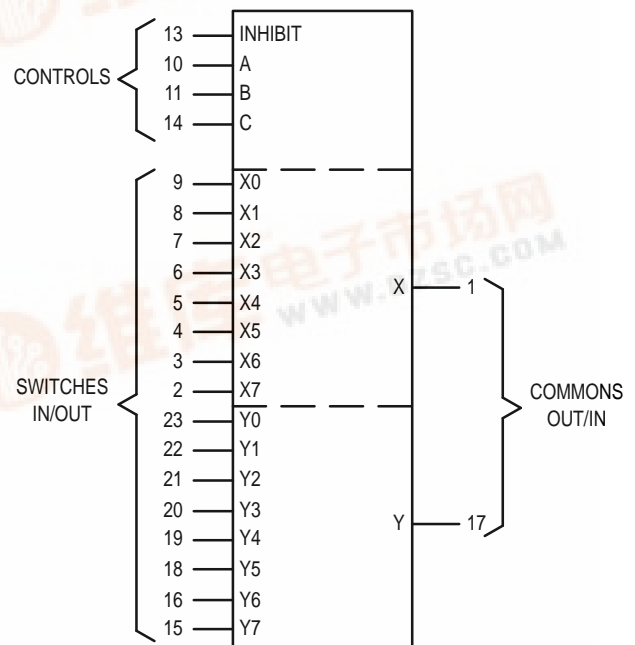

MAXIMUM RATINGS* (Voltages Referenced to V_{SS})

Symbol	Parameter	Value	Unit
V_{DD}	DC Supply Voltage	- 0.5 to + 18.0	V
V_{in}, V_{out}	Input or Output Voltage (DC or Transient)	- 0.5 to $V_{DD} + 0.5$	V
I_{in}	Input Current (DC or Transient), per Control Pin	± 10	mA
I_{sw}	Switch Through Current	± 25	mA
P_D	Power Dissipation, per Package†	500	mW
T_{stg}	Storage Temperature	- 65 to + 150	°C
T_L	Lead Temperature (8-Second Soldering)	260	°C

* Maximum Ratings are those values beyond which damage to the device may occur.

† Temperature Derating:

Plastic "P and D/DW" Packages: - 7.0 mW/°C From 65°C To 125°C

Ceramic "L" Packages: - 12 mW/°C From 100°C To 125°C

This device contains protection circuitry to guard against damage due to high static voltages or electric fields. However, precautions must be taken to avoid applications of any voltage higher than maximum rated voltages to this high-impedance circuit. For proper operation, V_{in} and V_{out} should be constrained to the range $V_{SS} \leq (V_{in} \text{ or } V_{out}) \leq V_{DD}$. Unused inputs must always be tied to an appropriate logic voltage level (e.g., either V_{SS} or V_{DD}). Unused outputs must be left open.

MC14067 TRUTH TABLE

Control Inputs					Selected Channel
A	B	C	D	Inh	
X	X	X	X	1	None
0	0	0	0	0	X0
1	0	0	0	0	X1
0	1	0	0	0	X2
1	1	0	0	0	X3
0	0	1	0	0	X4
1	0	1	0	0	X5
0	1	1	0	0	X6
1	1	1	0	0	X7
0	0	0	1	0	X8
1	0	0	1	0	X9
0	1	0	1	0	X10
1	1	0	1	0	X11
0	0	1	1	0	X12
1	0	1	1	0	X13
0	1	1	1	0	X14
1	1	1	1	0	X15

MC14097 TRUTH TABLE

Control Inputs				Selected Channels	
A	B	C	Inh		
X	X	X	1	None	
0	0	0	0	X0	Y0
1	0	0	0	X1	Y1
0	1	0	0	X2	Y2
1	1	0	0	X3	Y3
0	0	1	0	X4	Y4
1	0	1	0	X5	Y5
0	1	1	0	X6	Y6
1	1	1	0	X7	Y7

X = Don't Care

MC14067 FUNCTIONAL DIAGRAM

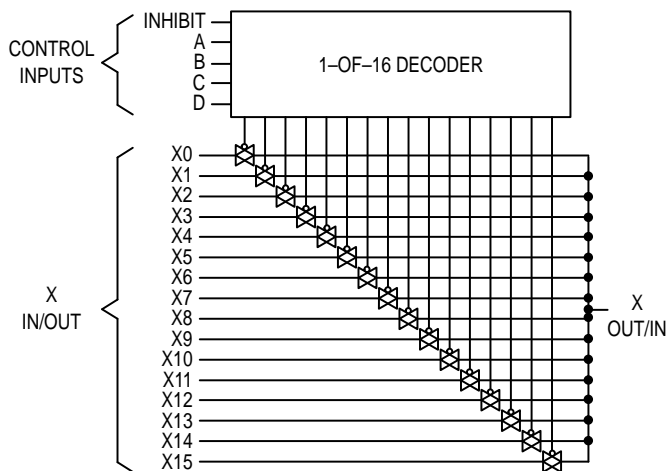

MC14097 FUNCTIONAL DIAGRAM

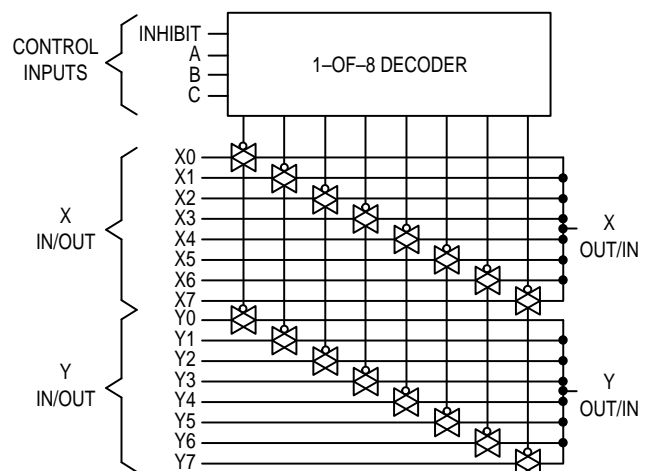

ELECTRICAL CHARACTERISTICS

Characteristic	Symbol	V _{DD}	Test Conditions	- 55°C		25°C			125°C		Unit
				Min	Max	Min	Typ #	Max	Min	Max	

SUPPLY REQUIREMENTS (Voltages Referenced to V_{SS})

Power Supply Voltage Range	V _{DD}	—		3.0	18	3.0	—	18	3.0	18	V
Quiescent Current Per Package	I _{DD}	5.0 10 15	Control Inputs: V _{in} = V _{SS} or V _{DD} , Switch I/O: V _{SS} ≤ V _{I/O} ≤ V _{DD} , and ΔV _{switch} ≤ 500 mV**	— — —	5.0 10 20	— — —	0.005 0.010 0.015	5.0 10 20	— — —	150 300 600	μA
Total Supply Current (Dynamic Plus Quiescent, Per Package)	I _{D(AV)}	5.0 10 15	T _A = 25°C only (The channel component, (V _{in} - V _{out})/R _{on} , is not included.)	Typical						(0.07 μA/kHz) f + I _{DD} (0.20 μA/kHz) f + I _{DD} (0.36 μA/kHz) f + I _{DD}	μA

CONTROL INPUTS — INHIBIT, A, B, C, D (Voltages Referenced to V_{SS})

Low-Level Input Voltage	V _{IL}	5.0 10 15	R _{on} = per spec, I _{off} = per spec	— — —	1.5 3.0 4.0	— — —	2.25 4.50 6.75	1.5 3.0 4.0	— — —	1.5 3.0 4.0	V
High-Level Input Voltage	V _{IH}	5.0 10 15	R _{on} = per spec, I _{off} = per spec	3.5 7.0 11	— — —	3.5 7.0 11	2.75 5.50 8.25	— — —	3.5 7.0 11	— — —	V
Input Leakage Current	I _{in}	15	V _{in} = 0 or V _{DD}	—	± 0.1	—	± 0.00001	± 0.1	—	1.0	μA
Input Capacitance	C _{in}	—		—	—	—	5.0	7.5	—	—	pF

SWITCHES IN/OUT AND COMMONS OUT/IN — X, Y (Voltages Referenced to V_{SS})

Recommended Peak-to-Peak Voltage Into or Out of the Switch	V _{I/O}	—	Channel On or Off	0	V _{DD}	0	—	V _{DD}	0	V _{DD}	V _{p-p}
Recommended Static or Dynamic Voltage Across the Switch* (Figure 1)	ΔV _{switch}	—	Channel On	0	600	0	—	600	0	300	mV
Output Offset Voltage	V _{OO}	—	V _{in} = 0 V, No Load	—	—	—	10	—	—	—	μV
ON Resistance	R _{on}	5.0 10 15	ΔV _{switch} ≤ 500 mV**, V _{in} = V _{IL} or V _{IH} (Control), and V _{in} 0 to V _{DD} (Switch)	— — —	800 400 220	— — —	250 120 80	1050 500 280	— — —	1300 550 320	Ω
ΔON Resistance Between Any Two Channels in the Same Package	ΔR _{on}	5.0 10 15		— — —	70 50 45	— — —	25 10 10	70 50 45	— — —	135 95 65	Ω
Off-Channel Leakage Current (Figure 2)	I _{off}	15	V _{in} = V _{IL} or V _{IH} (Control) Channel to Channel or Any One Channel	—	± 100	—	± 0.05	± 100	—	± 1000	nA
Capacitance, Switch I/O	C _{I/O}	—	Inhibit = V _{DD}	—	—	—	10	—	—	—	pF
Capacitance, Common O/I	C _{O/I}	—	Inhibit = V _{DD} (MC14067B) (MC14097B)	— —	— —	— —	100 60	— —	— —	— —	pF
Capacitance, Feedthrough (Channel Off)	C _{I/O}	—	Pins Not Adjacent Pins Adjacent	—	—	—	0.47	—	—	—	pF

Data labeled "Typ" is not to be used for design purposes, but is intended as an indication of the IC's potential performance.

** For voltage drops across the switch (ΔV_{switch}) > 600 mV (> 300 mV at high temperature), excessive V_{DD} current may be drawn; i.e. the current out of the switch may contain both V_{DD} and switch input components. The reliability of the device will be unaffected unless the Maximum Ratings are exceeded. (See first page of this data sheet.)

ELECTRICAL CHARACTERISTICS ($C_L = 50 \text{ pF}$, $T_A = 25^\circ\text{C}$)

Characteristic	Symbol	$V_{DD} - V_{SS}$ Vdc	Typ #	Max	Unit
Propagation Delay Times Channel Input-to-Channel Output ($R_L = 200 \text{ k}\Omega$) MC14067B MC14097B Control Input-to-Channel Output Channel Turn-On Time ($R_L = 10 \text{ k}\Omega$) MC14067B/097B Channel Turn-Off Time ($R_L = 300 \text{ k}\Omega$) MC14067B/097B Any Pair of Address Inputs to Output MC14067B MC14097B	t_{PLH}, t_{PHL} (Figure 3)	5.0	35	90	ns
		10	15	40	
	15	12	30		
	5.0	25	65	ns	
	10	10	25		
	15	7	18		
	t_{PZH}, t_{PZL} (Figure 4)	5.0	240	600	ns
		10	115	290	
	15	75	190		
	t_{PHZ}, t_{PLZ} (Figure 4)	5.0	250	625	ns
10		120	300		
15	75	190			
t_{PLH}, t_{PHL} (Figure 10)	5.0	280	700	ns	
	10	115	290		
15	85	215			
5.0	250	625	ns		
10	100	250			
15	75	190			
Second Harmonic Distortion ($R_L = 10 \text{ k}\Omega$, $f = 1 \text{ kHz}$, $V_{in} = 5 V_{p-p}$)	—	10	0.3	—	%
ON Channel Bandwidth [$R_L = 1 \text{ k}\Omega$, $V_{in} = 1/2 (V_{DD} - V_{SS})$ p-p(sine-wave)] $20 \text{ Log}_{10} (V_{out}/V_{in}) = -3 \text{ dB}$	BW (Figure 5)	10	15	—	MHz
		10	25	—	
Off Channel Feedthrough Attenuation [$R_L = 1 \text{ k}\Omega$, $V_{in} = 1/2 (V_{DD} - V_{SS})$ p-p(sine-wave)] $f_{in} = 20 \text{ MHz}$ – MC14067B $f_{in} = 12 \text{ MHz}$ – MC14097B	— (Figure 5)	10	-40	—	dB
Channel Separation [$R_L = 1 \text{ k}\Omega$, $V_{in} = 1/2 (V_{DD} - V_{SS})$ p-p (sine-wave)] $f_{in} = 20 \text{ MHz}$	— (Figure 6)	10	-40	—	dB
Crosstalk, Control Inputs-to-Common O/I ($R_1 = 1 \text{ k}\Omega$, $R_L = 10 \text{ k}\Omega$, Control $t_r = t_f = 20 \text{ ns}$, Inhibit = V_{SS})	— (Figure 7)	10	30	—	mV

#Data labelled "Typ" is not to be used for design purposes but is intended as an indication of the IC's potential performance.

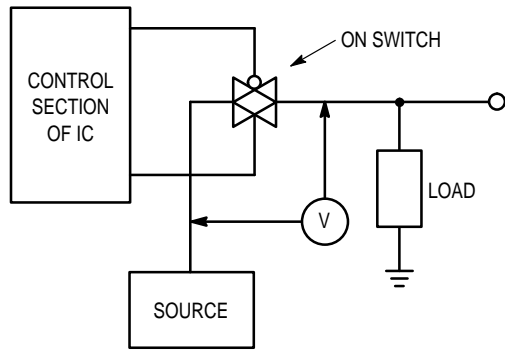

Figure 1. ΔV Across Switch

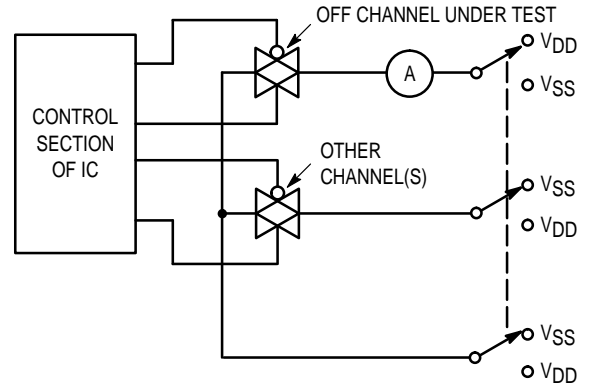

Figure 2. Off Channel Leakage

**MC14067B
PIN ASSIGNMENT**

X	1	•	24	V _{DD}
X7	2		23	X8
X6	3		22	X9
X5	4		21	X10
X4	5		20	X11
X3	6		19	X12
X2	7		18	X13
X1	8		17	X14
X0	9		16	X15
A	10		15	INHIBIT
B	11		14	C
V _{SS}	12		13	D

**MC14097B
PIN ASSIGNMENT**

X	1	•	24	V _{DD}
X7	2		23	Y0
X6	3		22	Y1
X5	4		21	Y2
X4	5		20	Y3
X3	6		19	Y4
X2	7		18	Y5
X1	8		17	Y
X0	9		16	Y6
A	10		15	Y7
B	11		14	C
V _{SS}	12		13	INHIBIT

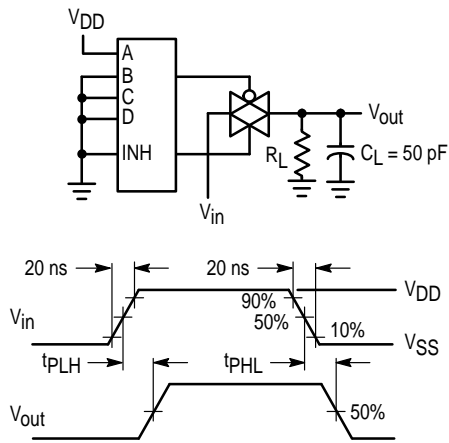

Figure 3. Propagation Delay Test Circuit and Waveforms V_{in} to V_{out}

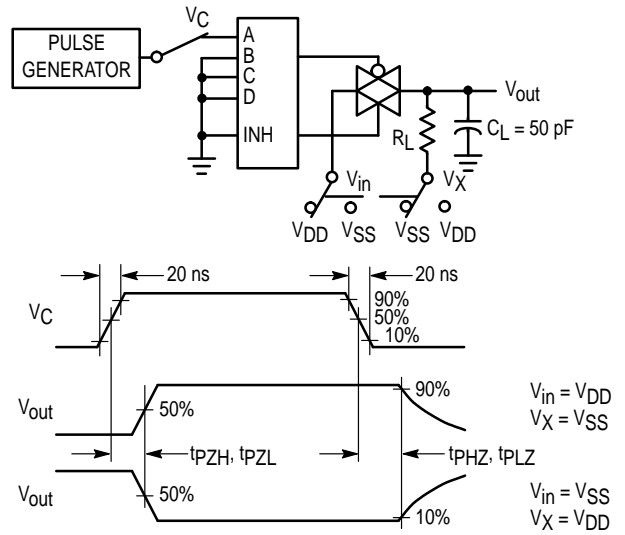

Figure 4. Turn-On and Delay Turn-Off Test Circuit and Waveforms

A, B, and C inputs used to turn ON or OFF the switch under test.

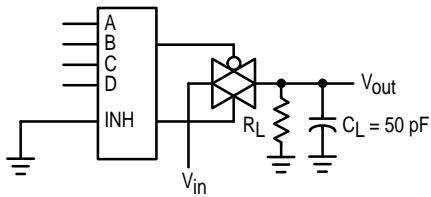

Figure 5. Bandwidth and Off-Channel Feedthrough Attenuation

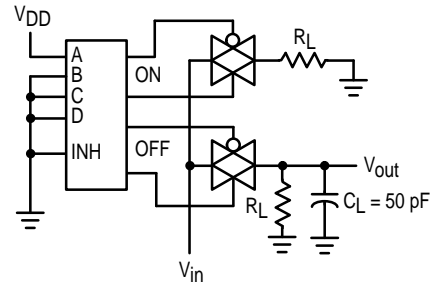

Figure 6. Channel Separation (Adjacent Channels Used for Setup)

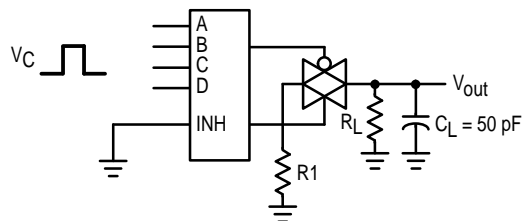

Figure 7. Crosstalk, Control to Common O/I

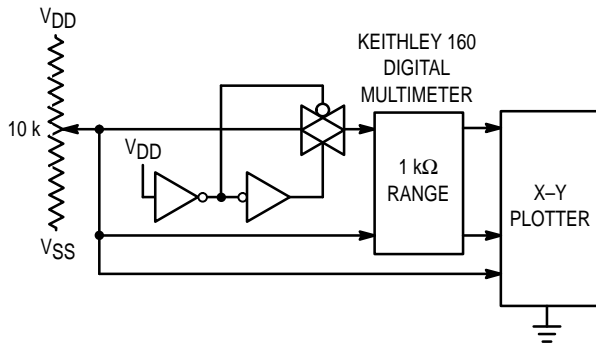

Figure 8. Channel Resistance (R_{ON}) Test Circuit

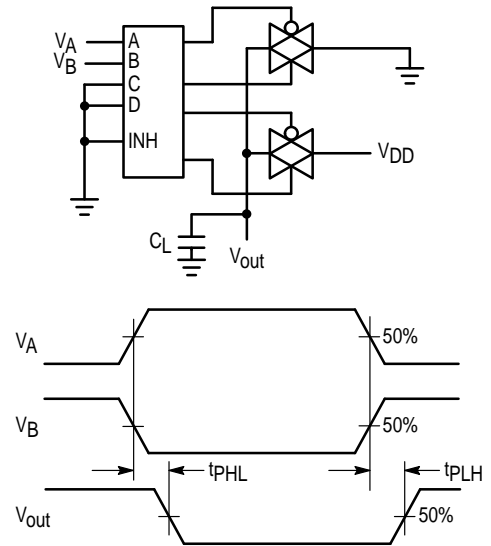

Figure 9. Propagation Delay, Any Pair of Address Inputs to Output

TYPICAL RESISTANCE CHARACTERISTICS

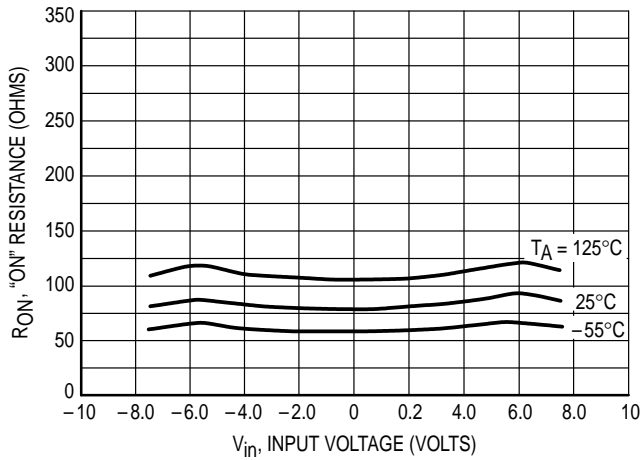

Figure 10. $V_{DD} = 7.5\text{ V}$, $V_{SS} = -7.5\text{ V}$

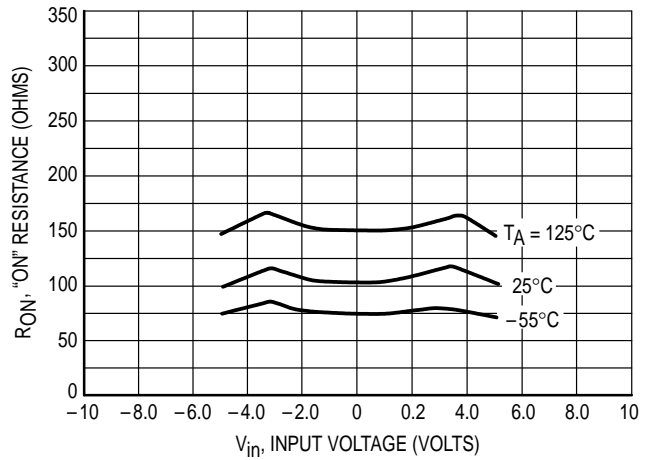

Figure 11. $V_{DD} = 5.0\text{ V}$, $V_{SS} = -5.0\text{ V}$

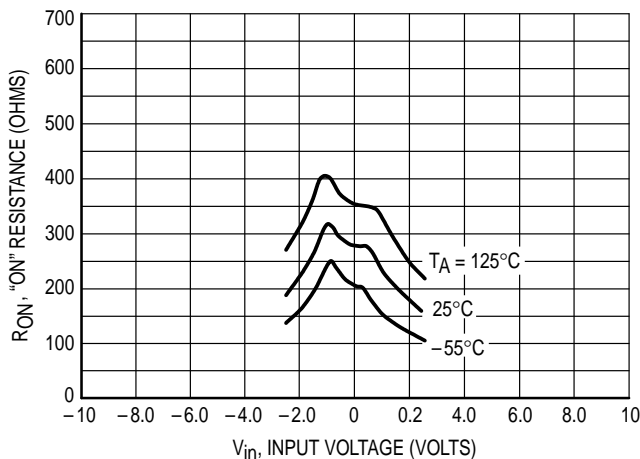

Figure 12. $V_{DD} = 2.5\text{ V}$, $V_{SS} = -2.5\text{ V}$

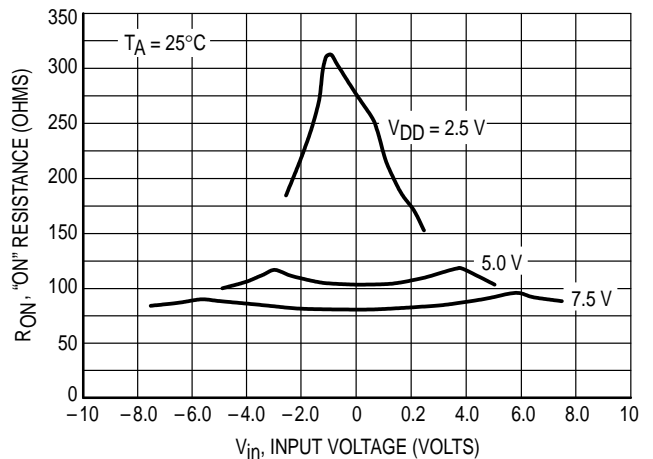

Figure 13. Comparison at 25°C , $V_{DD} = -V_{SS}$

APPLICATIONS INFORMATION

Figure A illustrates use of the Analog Multiplexer/Demultiplexer. The 0-to-5 volt Digital Control signal is used to directly control a 5 V_{p-p} analog signal.

The digital control logic levels are determined by V_{DD} and V_{SS} . The V_{DD} voltage is the logic high voltage; the V_{SS} voltage is logic low. For the example, $V_{DD} = +5\text{ V} = \text{logic high}$ at the control inputs; $V_{SS} = \text{GND} = 0\text{ V} = \text{logic low}$.

The maximum analog signal level is determined by V_{DD} and V_{SS} . The analog voltage must swing neither higher than V_{DD} nor lower than V_{SS} . The example shows a 5 V_{p-p} signal

which allows no margin at either peak. If voltage transients above V_{DD} and/or below V_{SS} are anticipated on the analog channels, external diodes (D_X) are recommended as shown in Figure B. These diodes should be small signal types able to absorb the maximum anticipated current surges during clipping.

The absolute maximum potential difference between V_{DD} and V_{SS} is 18.0 volts. Most parameters are specified up to 15 V which is the recommended maximum difference between V_{DD} and V_{SS} .

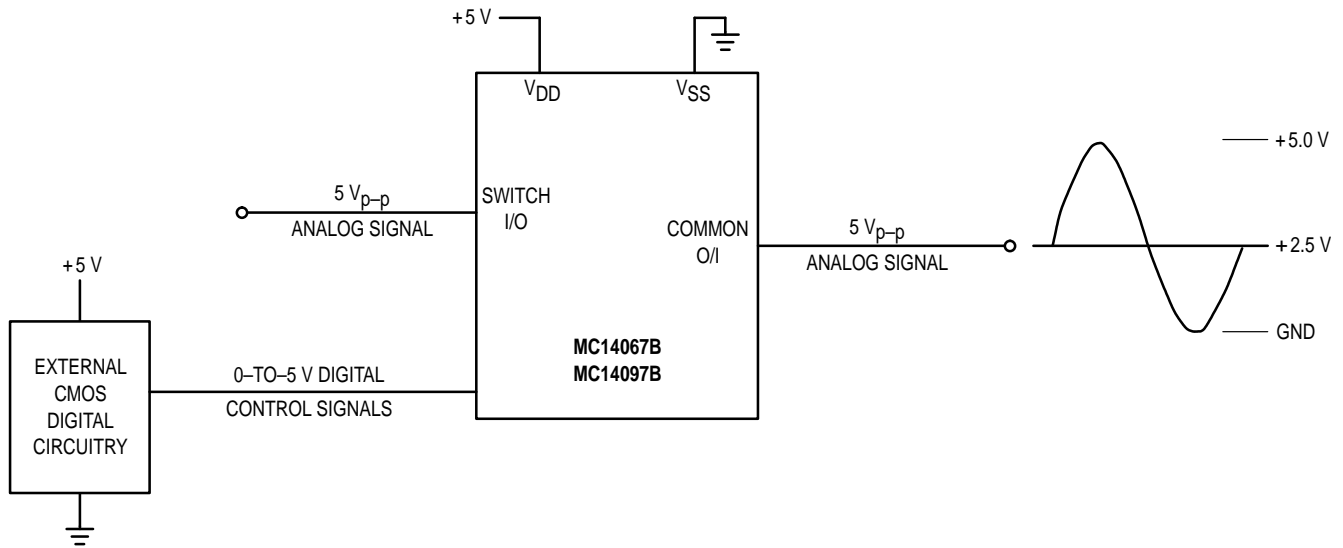

Figure A. Application Example

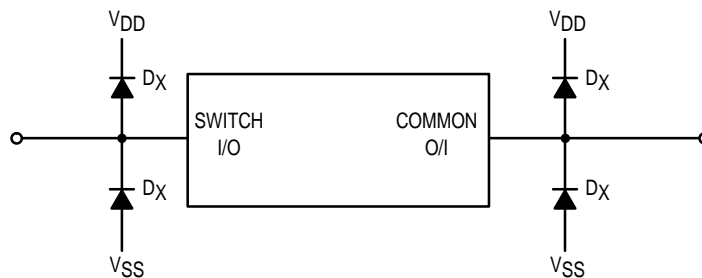
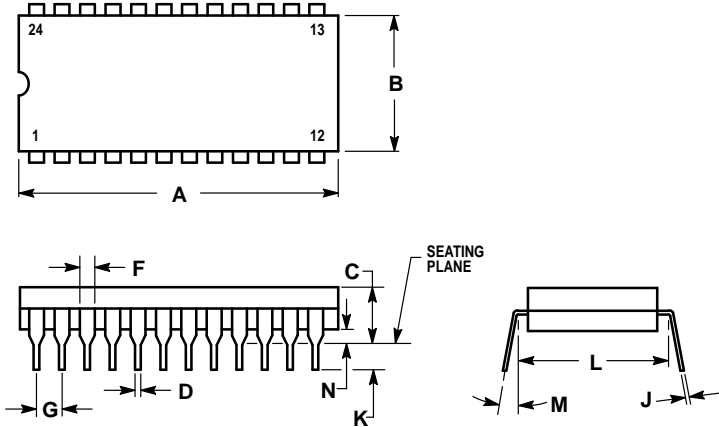

Figure B. External Germanium or Schottky Clipping Diodes

OUTLINE DIMENSIONS

L SUFFIX CERAMIC DIP PACKAGE CASE 623-05 ISSUE M



NOTES:

1. DIMENSION L TO CENTER OF LEADS WHEN FORMED PARALLEL.
2. LEADS WITHIN 0.13 (0.005) RADIUS OF TRUE POSITION AT SEATING PLANE AT MAXIMUM MATERIAL CONDITION (WHEN FORMED PARALLEL).

DIM	MILLIMETERS		INCHES	
	MIN	MAX	MIN	MAX
A	31.24	32.77	1.230	1.290
B	12.70	15.49	0.500	0.610
C	4.06	5.59	0.160	0.220
D	0.41	0.51	0.016	0.020
F	1.27	1.52	0.050	0.060
G	2.54 BSC		0.100 BSC	
J	0.20	0.30	0.008	0.012
K	3.18	4.06	0.125	0.160
L	15.24 BSC		0.600 BSC	
M	0°	15°	0°	15°
N	0.51	1.27	0.020	0.050

P SUFFIX PLASTIC DIP PACKAGE CASE 709-02 ISSUE C

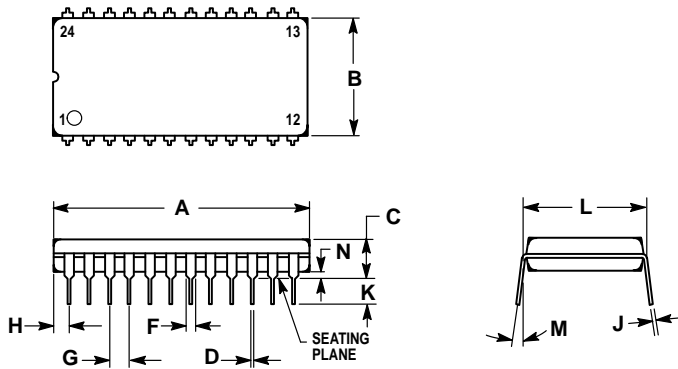

NOTES:

1. POSITIONAL TOLERANCE OF LEADS (D), SHALL BE WITHIN 0.25 (0.010) AT MAXIMUM MATERIAL CONDITION, IN RELATION TO SEATING PLANE AND EACH OTHER.
2. DIMENSION L TO CENTER OF LEADS WHEN FORMED PARALLEL.
3. DIMENSION B DOES NOT INCLUDE MOLD FLASH.

DIM	MILLIMETERS		INCHES	
	MIN	MAX	MIN	MAX
A	31.37	32.13	1.235	1.265
B	13.72	14.22	0.540	0.560
C	3.94	5.08	0.155	0.200
D	0.36	0.56	0.014	0.022
F	1.02	1.52	0.040	0.060
G	2.54 BSC		0.100 BSC	
H	1.65	2.03	0.065	0.080
J	0.20	0.38	0.008	0.015
K	2.92	3.43	0.115	0.135
L	15.24 BSC		0.600 BSC	
M	0°	15°	0°	15°
N	0.51	1.02	0.020	0.040

OUTLINE DIMENSIONS

DW SUFFIX PLASTIC SOIC PACKAGE CASE 751E-04 ISSUE E

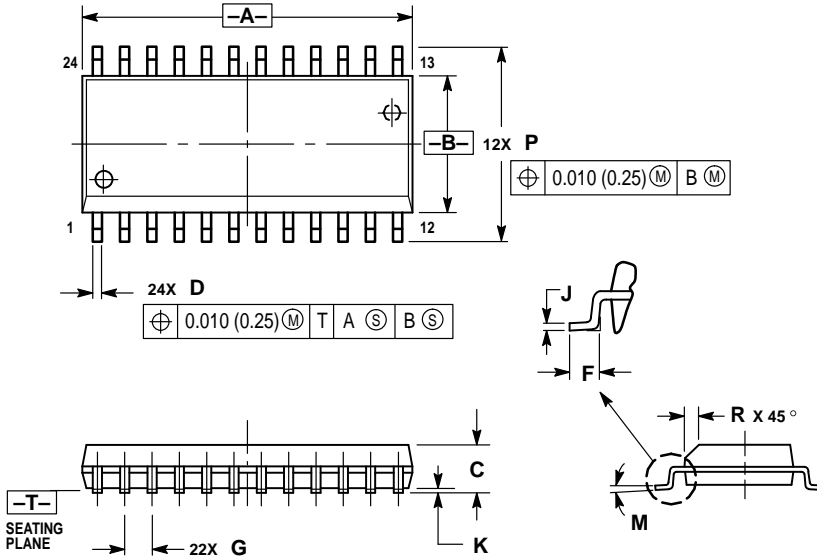

NOTES:

1. DIMENSIONING AND TOLERANCING PER ANSI Y14.5M, 1982.
2. CONTROLLING DIMENSION: MILLIMETER.
3. DIMENSIONS A AND B DO NOT INCLUDE MOLD PROTRUSION.
4. MAXIMUM MOLD PROTRUSION 0.15 (0.006) PER SIDE.
5. DIMENSION D DOES NOT INCLUDE DAMBAR PROTRUSION. ALLOWABLE DAMBAR PROTRUSION SHALL BE 0.13 (0.005) TOTAL IN EXCESS OF D DIMENSION AT MAXIMUM MATERIAL CONDITION.

DIM	MILLIMETERS		INCHES	
	MIN	MAX	MIN	MAX
A	15.25	15.54	0.601	0.612
B	7.40	7.60	0.292	0.299
C	2.35	2.65	0.093	0.104
D	0.35	0.49	0.014	0.019
F	0.41	0.90	0.016	0.035
G	1.27 BSC		0.050 BSC	
J	0.23	0.32	0.009	0.013
K	0.13	0.29	0.005	0.011
M	0°	8°	0°	8°
P	10.05	10.55	0.395	0.415
R	0.25	0.75	0.010	0.029

Motorola reserves the right to make changes without further notice to any products herein. Motorola makes no warranty, representation or guarantee regarding the suitability of its products for any particular purpose, nor does Motorola assume any liability arising out of the application or use of any product or circuit, and specifically disclaims any and all liability, including without limitation consequential or incidental damages. "Typical" parameters which may be provided in Motorola data sheets and/or specifications can and do vary in different applications and actual performance may vary over time. All operating parameters, including "Typicals" must be validated for each customer application by customer's technical experts. Motorola does not convey any license under its patent rights nor the rights of others. Motorola products are not designed, intended, or authorized for use as components in systems intended for surgical implant into the body, or other applications intended to support or sustain life, or for any other application in which the failure of the Motorola product could create a situation where personal injury or death may occur. Should Buyer purchase or use Motorola products for any such unintended or unauthorized application, Buyer shall indemnify and hold Motorola and its officers, employees, subsidiaries, affiliates, and distributors harmless against all claims, costs, damages, and expenses, and reasonable attorney fees arising out of, directly or indirectly, any claim of personal injury or death associated with such unintended or unauthorized use, even if such claim alleges that Motorola was negligent regarding the design or manufacture of the part. Motorola and  are registered trademarks of Motorola, Inc. Motorola, Inc. is an Equal Opportunity/Affirmative Action Employer.

How to reach us:

USA/EUROPE/Locations Not Listed: Motorola Literature Distribution;
P.O. Box 20912; Phoenix, Arizona 85036. 1-800-441-2447 or 602-303-5454

MFAX: RMFAX0@email.sps.mot.com - TOUCHTONE 602-244-6609
INTERNET: <http://Design-NET.com>

JAPAN: Nippon Motorola Ltd.; Tatsumi-SPD-JLDC, 6F Seibu-Butsuryu-Center,
3-14-2 Tatsumi Koto-Ku, Tokyo 135, Japan. 03-81-3521-8315

ASIA/PACIFIC: Motorola Semiconductors H.K. Ltd.; 8B Tai Ping Industrial Park,
51 Ting Kok Road, Tai Po, N.T., Hong Kong. 852-26629298