

October 2000

LM2469 Monolithic Triple 9nS High Gain CRT Driver

General Description

The LM2469 is an integrated high voltage CRT driver circuit designed for use in color monitor applications. The IC contains three high impedance wide band amplifiers, which directly drive the RGB cathodes of a CRT. Each channel has its gain internally set to -20 and can drive CRT capacitive loads as well as resistive loads present in other applications, limited only by the package's power dissipation. The IC is packaged in an industry standard 9 lead TO-220 molded plastic package.

Features

- Higher gain to match LM126X CMOS preamplifiers

- 0V to 3.75V input range
- Stable with 0-20pF capacitive loads and inductive peaking networks
- Maintains standard LM243X Family Pinout which is designed for easy PCB layout
- Convenient TO-220 staggered 9 lead package style

Applications

- Up to 1024 X 768 at 70Hz
- Pixel clock frequencies up to 75MHz
- Monitors using video blanking

Schematic Diagram

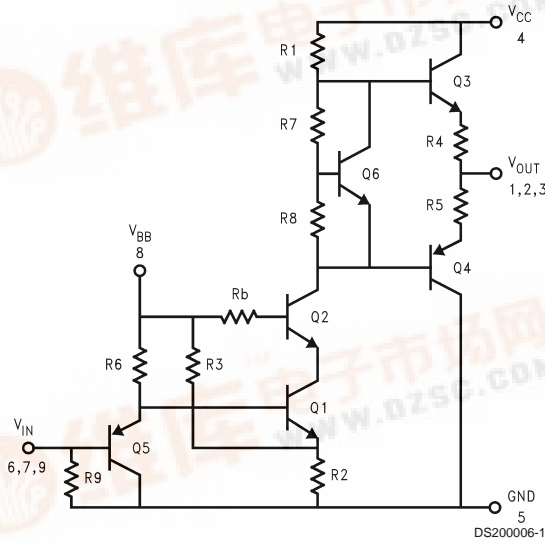
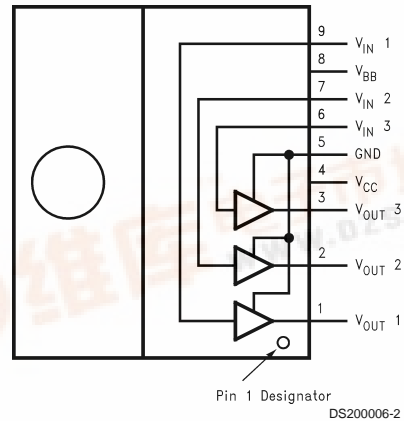

FIGURE 1. Simplified Schematic Diagram (One Channel)

Connection Diagram



Note: Tab is at GND.

FIGURE 2. Top View
Order Number: LM2469TA
NS package Number: TA09A

LM2469 Monolithic Triple 9nS High Gain CRT Driver



Absolute Maximum Ratings (Notes 1, 3)

If Military/Aerospace specified devices are required, please contact the National Semiconductor Sales Office/Distributors for availability and specifications.

Supply Voltage, V_{CC}	+90V
Bias Voltage, V_{BB}	+16V
Input Voltage, V_{IN}	0V to 4.5V
Storage Temperature Range, T_{STG}	-65°C to +150°C
Lead Temperature (Soldering, <10sec.)	300°C
ESD Tolerance, Human Body Model	2kV

Limits of Operating Ranges (Note 2)

V_{CC}	+60V to +85V
V_{BB}	+8V to 15V
V_{IN}	0V to +3.75V
V_{OUT}	+15V to +75V
Case Temperature	-20°C to +100°C

Do not operate the part without a heat sink.

Electrical Characteristics

(See Figure 3 for Test Circuit)

Unless otherwise noted: $V_{CC} = +80V$, $V_{BB} = +12V$, $C_L = 8pF$, $T_C = 50^\circ C$.

DC Tests: $V_{IN} = +2.25V_{DC}$

AC Tests: Output = $40V_{PP}$ (25V - 65V) at 1MHz

Symbol	Spec Parameter	Conditions	Min	Typ	Max	Units
I_{CC}	Supply Current	Per Channel, No Input Signal, No Output Load		8	12	mA
I_{BB}	Bias Current	All three Channels		15	25	mA
V_{OUT}	DC Output Voltage	No AC Input Signal, $V_{IN} = 1.25V$	62	65	68	V_{DC}
A_V	DC Voltage Gain	No AC Input Signal	-18	-20	-22	
ΔA_V	Gain Matching	Note 4, No AC Input Signal		1.0		dB
LE	Linearity Error	Note 4, 5, No AC Input Signal		5		%
t_R	Rise Time	Note 6, 10% to 90%		9.5		nS
t_F	Fall Time	Note 6, 90% to 10%		10.5		nS
OS	Overshoot	Note 6		5		%

Note 1: Absolute Maximum Ratings indicate limits beyond which damage to the device may occur.

Note 2: Operating Ratings indicate conditions for which the device is functional, but do not guarantee specific performance limits. For guaranteed specifications and the test conditions, see the Electrical Characteristics. The guaranteed specifications apply only for the test conditions listed. Some performance characteristics may change when the device is not operated under the listed test conditions.

Note 3: All voltages are measured with respect to GND, unless otherwise specified.

Note 4: Calculated value from Voltage Gain test on each channel.

Note 5: Linearity Error is the variation in DC Gain from $V_{in} = 1.0$ volts to $V_{in} = 3.5$ volts.

Note 6: Input from signal generator: $t_R, t_F < 1nS$.

AC Test Circuit

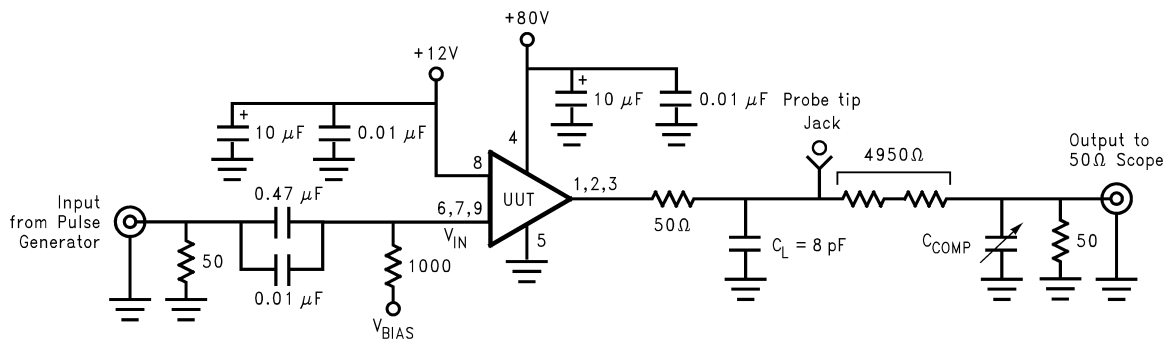

FIGURE 3. Test Circuit (One Channel)

DS200006-3

Typical Performance Characteristics

($V_{CC} = +80V_{DC}$, $V_{BB} = +12V_{DC}$, $C_L = +8pF$, $V_{OUT} = 40V_{PP}$ (25-65V), Test Circuit - Figure 3 unless otherwise specified.)

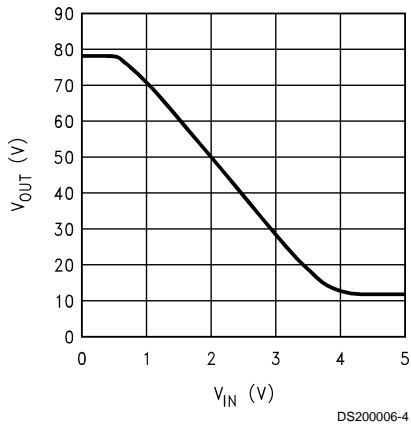

Figure 9: V_{out} vs V_{in}

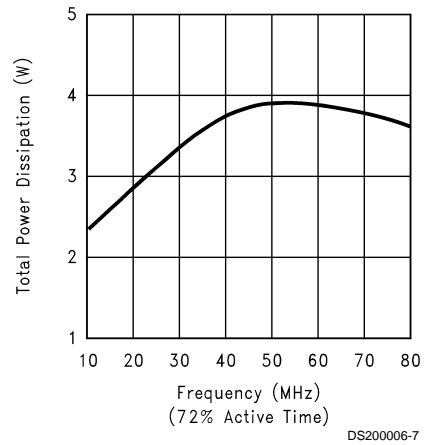

Figure 10: Power Dissipation vs Frequency

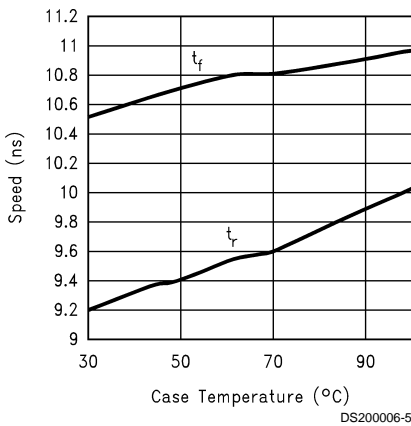

Figure 11: Speed vs Temperature

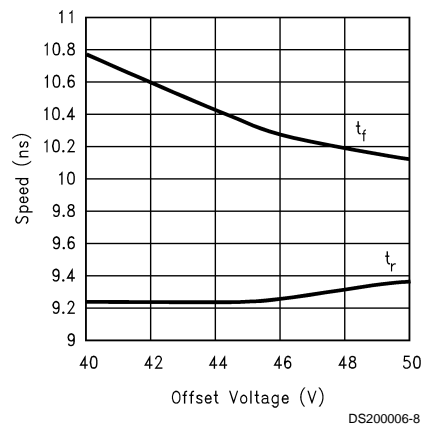

Figure 12: Speed vs Offset

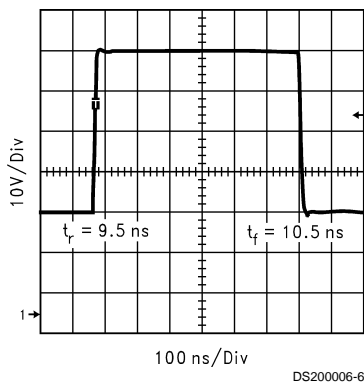

Figure 13: LM2469 Pulse Response

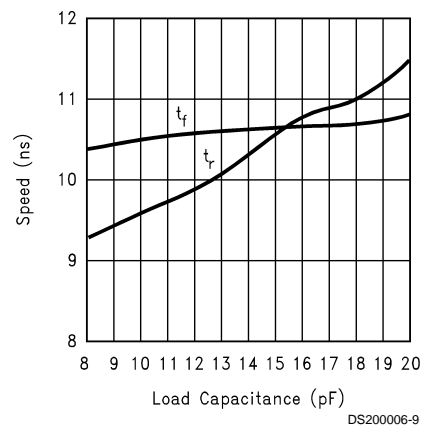

Figure 14: Speed vs Load Capacitance

THEORY OF OPERATION

The LM2469 is a high voltage monolithic three channel CRT driver suitable for color monitor applications. The LM2469 operates with 80V and 12V power supplies. The part is housed in the industry standard 9-lead TO-220 molded plastic power package.

The circuit diagram of the LM2469 is shown in Figure 1. The PNP emitter follower, Q5, provides input buffering. Q1 and Q2 form a fixed gain cascode amplifier with resistors R1 and R2 setting the gain at -20. Emitter followers Q3 and Q4 isolate the high output impedance of the amplifier from the capacitive load on the output of the amplifier, decreasing the sensitivity of the device to changes in load capacitance. Q6 provides biasing to the output emitter follower stage to reduce crossover distortion at low signal levels.

Figure 3 shows a typical test circuit for evaluation of the LM2469. This circuit is designed to allow testing of the LM2469 in a 50Ω environment without the use of an expensive FET probe. In this test circuit, two low inductance resistors in series totalling 4.95KΩ form a 200:1 wideband, low capacitance probe when connected to a 50Ω load (such as 50Ω oscilloscope input). The input signal from the generator is AC coupled to the base of Q5.

APPLICATION HINTS

INTRODUCTION

National Semiconductor (NSC) is committed to provide application information that assists our customers in obtaining the best performance possible from our products. The following information is provided in order to support this commitment. The reader should be aware that the optimization of performance was done using a specific printed circuit board designed at NSC. Variations in performance can be realized due to physical changes in the printed circuit board and the application. Therefore, the designer should know that component value changes might be required in order to optimize performance in a given application. The values shown in this document can be used as a starting point for evaluation purposes. When working with high bandwidth circuits, good layout practices are always critical to achieving maximum performance.

IMPORTANT INFORMATION

The LM2469 performance is targeted for the VGA (640 x 480) to XGA (1024 x 768, 70Hz refresh) resolution market. It is designed to be a replacement for discrete CRT drivers. The application circuits shown in this document to optimize performance and to protect against damage from CRT arc-over are designed specifically for the LM2469. If another member of the LM246X family is used, please refer to its datasheet.

POWER SUPPLY BYPASS

Since the LM2469 is a wide bandwidth amplifier, proper power supply bypassing is critical for optimum performance. Improper power supply bypassing can result in large overshoot, ringing or oscillation. A 0.1μF capacitor should be connected from the supply pin, V_{CC} , to ground, as close to the supply and ground pins as is practical. Additionally, a 10μF to 100μF electrolytic capacitor should be connected from the supply pin to ground. The electrolytic capacitor should also be placed reasonably close to the LM2469's

supply and ground pins. A 0.1μF capacitor should be connected from the bias pin (V_{bb}) to the ground, as close as is practical to the part.

ARC PROTECTION

During normal CRT operation, internal arcing may occasionally occur. Spark gaps, in the range of 200V, connected from the CRT cathodes to CRT ground will limit the maximum voltage, but to a value that is much higher than allowable on the LM2469. This fast, high voltage, high energy pulse can damage the LM2469 output stage. The application circuit shown in Figure 4 is designed to help clamp the voltage at the output of the LM2469 to a safe level. The clamp diodes, D1 and D2, should have a fast transient response, high peak current rating, low series impedance and low shunt capacitance. FDH400 or equivalent diodes are recommended. Do not use 1N4148 diodes for the clamp diodes. D1 and D2 should have short, low impedance connections to V_{CC} and ground respectively. The cathode of D1 should be located very close to a separately decoupled bypass capacitor (C3 in Figure 4). The ground connection of D2 and the decoupling capacitor should be very close to the LM2469 ground. This will significantly reduce the high frequency voltage transients that the LM2469 would be subjected to during an arc-over condition. Resistor R2 limits the arc-over current that is seen by the diodes while R1 limits the current into the LM2469 as well as the voltage stress at the outputs of the device. R2 should be a 1/2W solid carbon type resistor. R1 can be a 1/4W metal or carbon film type resistor. Having large value resistors for R1 and R2 would be desirable, but has the effect of increasing rise and fall times. Inductor L1 is critical to reduce the initial high frequency voltage levels that the LM2469 would be subjected to. The inductor will not only help protect the device, but will also help optimize rise and fall times as well as minimize EMI. For proper arc protection, it is important to not omit any of the arc protection components shown in Figure 4.

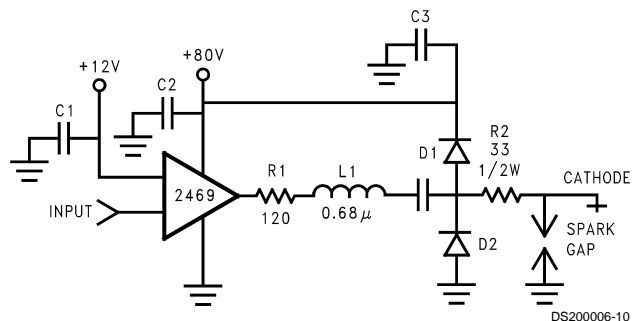

FIGURE 4. One Video Channel of the LM2469 with the Recommended Arc Protection Circuit

OPTIMIZING TRANSIENT RESPONSE

Referring to Figure 4, there are three components (R1, R2 and L1) that can be adjusted to optimize the transient response of the application circuit. Increasing the values of R1 and R2 will slow the circuit down while decreasing overshoot. Increasing the value of L1 will speed up the circuit as well as increase overshoot. It is very important to use inductors with very high self-resonant frequencies, preferably above 300 MHz. Ferrite core inductors from J.W. Miller Magnetics (part # 78FR39K) were used for optimizing the performance of the device in the NSC application board. The values shown in Figure 4 can be used as a good starting point for the evaluation of the LM2469. Using variable resis-

APPLICATION HINTS (Continued)

tors for R1 will simplify finding the values needed for optimum performance in a given application. Once the optimum value is determined, the variable resistors can be replaced with fixed values.

Effect of Load Capacitance

Figure 14 shows the effect of increased load capacitance on the speed of the device. This demonstrates the importance of knowing the load capacitance in the application. Note that the fall time stayed fairly constant while the rise time increased approximately 1.8% per pF.

Effect of Offset

Figure 12 shows the variation in rise and fall times when the output offset of the device is varied from 40VDC to 50 VDC. The rise time shows a maximum variation relative to the center data point (45 VDC) of less than 1.3%. The fall time shows a variation of about 3.9% relative to the center data point.

THERMAL CONSIDERATIONS

Figure 11 shows the performance of the LM2469 video amplifiers in the test circuit shown in Figure 3 as a function of case temperature. The figure shows that the rise time of the LM2469 increases by approximately 9% as the case temperature increases from 30°C to 100°C. This corresponds to a speed degradation of 1.3% for every 10°C rise in case temperature. The fall time degrades around 0.6% for every 10°C in case temperature.

Figure 10 shows the maximum power dissipation of the LM2469 vs. Frequency when all three channels of the device are driving an 8pF load with a 40 V_{p-p} signal alternating one pixel on, one pixel off. The graph assumes a 72% active time (device operating at the specified frequency) which is typical in a monitor application. The other 28% of the time the device is assumed to be sitting at the black level (65V in this case). This graph gives the designer the information needed to determine the heat sink requirement for his application. The designer should note that if the load capacitance is increased, the AC component of the total power dissipation will also increase.

The LM2469 case temperature must be maintained below 100°C. If the maximum expected ambient temperature is 70°C and the maximum power dissipation is 3.85W (from Figure 10, 50MHz bandwidth), then a maximum heat sink thermal resistance can be calculated:

$$R_{TH} = \frac{100^{\circ}\text{C} - 70^{\circ}\text{C}}{3.85\text{W}} = 7.8^{\circ}\text{C}/\text{W}$$

This example assumes a capacitive load of 8pF and no resistive load.

TYPICAL APPLICATION

The typical application of the LM2469 is shown in Figure 5 & 6. Used in conjunction with an LM126X and an LM2479/2480 bias clamp, a complete video channel from monitor input to CRT cathode can be achieved. Performance is ideal for 1024 x 768 resolution displays with pixel clock frequencies up to 75MHz. Figure 5 & 6 are the schematic for the NSC demonstration board that can be used to evaluate the LM126X/246X/2480 combination in a monitor.

PC Board Layout Considerations

For optimum performance, an adequate ground plane, isolation between channels, good supply bypassing and the minimization of unwanted feedback are necessary. Also, the length of the signal traces from the preamplifier to the LM2469 and from the LM2469 to the CRT cathode should be as short as possible. The following references are recommended:

Ott, Henry W., "Noise Reduction Techniques in Electronic Systems", John Wiley & Sons, New York, 1976.

"Video Amplifier Design for Computer Monitors", National Semiconductor Application Note 1013.

Pease, Robert A., "Troubleshooting Analog Circuits", Butterworth-Heinemann, 1991.

Because of its high small signal bandwidth, the part may oscillate in a monitor if feedback occurs around the video channel through the chassis wiring. To prevent this, leads to the video amplifier input circuit should be shielded, and input wiring should be spaced as far as possible from output circuit wiring.

NSC Demonstration Board

Figure 7 shows the routing and component placement on the NSC LM126X/246X demonstration board. The schematic of the board is shown in Figure 5 & 6. This board provides a good example of a layout that can be used as a guide for future layouts. Note the location of the following components:

- C16, C19—V_{CC} bypass capacitor, located very close to pin 4 and the ground plane near the device.
- C20—V_{BB} bypass capacitors, located close to pin 8 and ground.
- C46, C47, C48—V_{CC} bypass capacitors, near LM2469 V_{CC} clamp diodes. Very important for arc protection.

The routing of the LM2469 video outputs to the CRT is very critical to achieving optimum performance. Figure 8 shows the routing and component placement from pin 3 of the LM2469 to the blue cathode. Note that the components are placed so that they almost line up from the output pin of the LM2469 to the blue cathode pin of the CRT connector. This is done to minimize the length of the video path between these two components. Note also that D8, D9, R24, and D6 are placed to minimize the size of the video nodes that they are attached to. This minimizes parasitic capacitance in the video path and also enhances the effectiveness of the protection diodes. The anode of protection diode D8 is connected directly to a section of the ground plane that has a short and direct path to the LM2469 ground pins. The cathode of D9 is connected to V_{CC} very close to decoupling capacitor C48 (see Figure 8), which is connected to the same section of the ground plane as D8. The diode placement and routing is very important for minimizing the voltage stress on the LM2469 video outputs during an arc over event. Lastly, notice that S3 is placed very close to the blue cathode and is tied directly to the ground under the CRT connector.

APPLICATION HINTS (Continued)

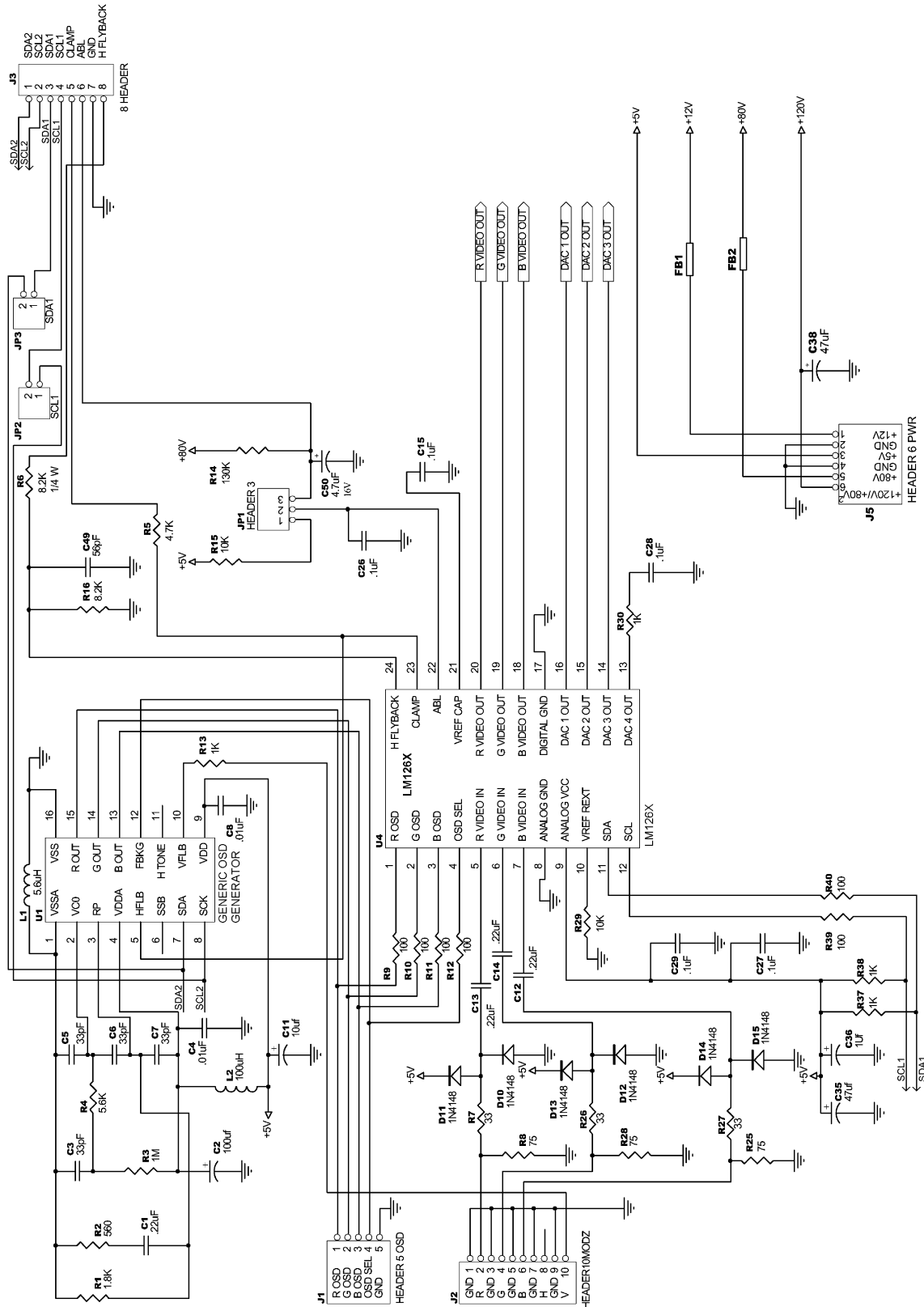

DS200006-29

FIGURE 5. LM126X/246X Demonstration Board Schematic

APPLICATION HINTS (Continued)

LM2469

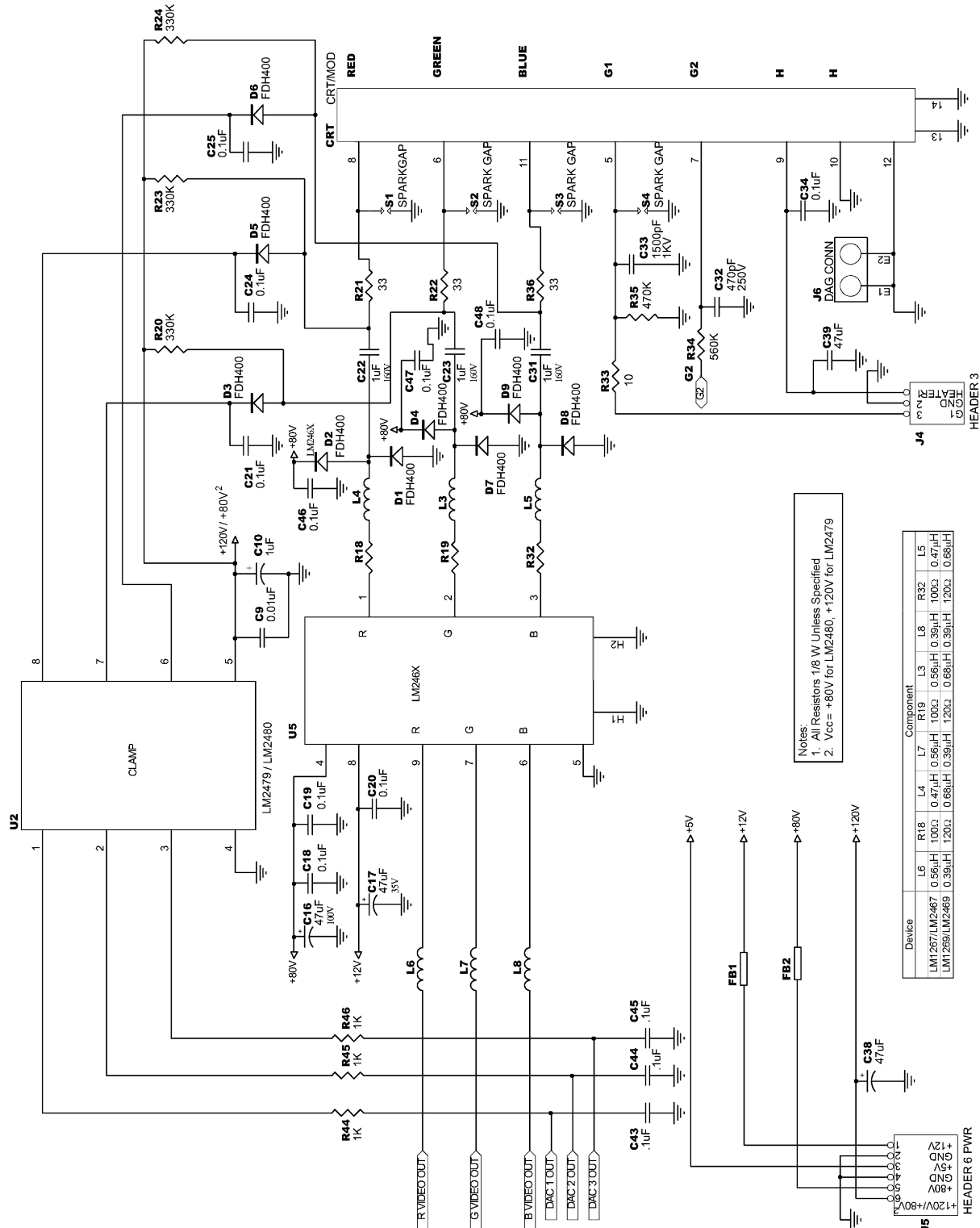

Notes:
 1. All Resistors 1/8 W Unless Specified
 2. V_{cc} = +80V for LM2480, +120V for LM2479

Device	L6	R18	L4	L7	L3	L8	R32	L5
LM1267/LM2467	0.56μH	100Ω	0.47μH	0.56μH	100Ω	0.56μH	100Ω	0.47μH
LM1269/LM2469	0.39μH	120Ω	0.68μH	0.39μH	120Ω	0.68μH	120Ω	0.68μH

DS200006-30

FIGURE 6. LM126X/246X Demonstration Board Schematic (continued)

APPLICATION HINTS (Continued)

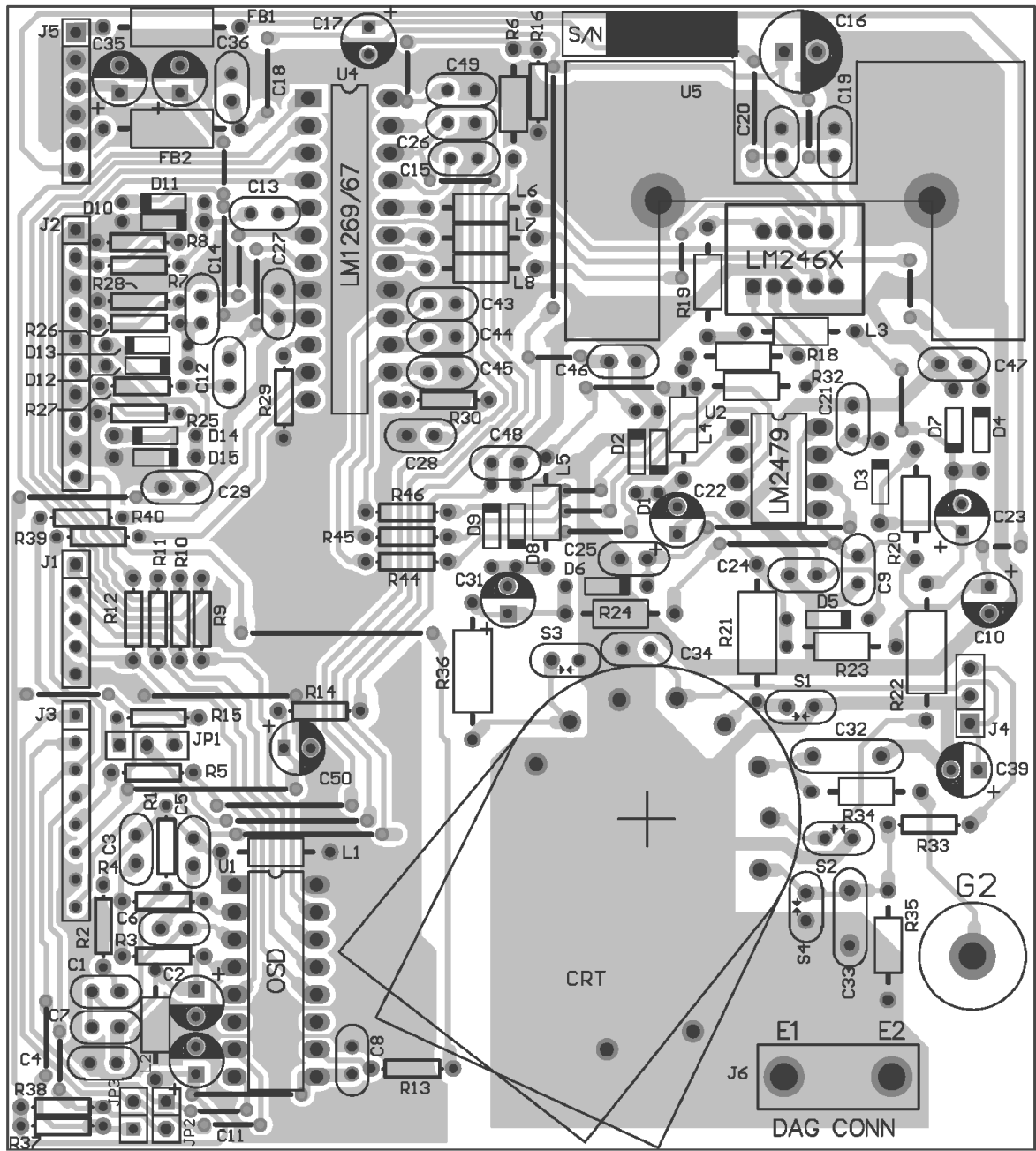

DS200006-17

FIGURE 7. NSC LM126X/246X Demo Board Layout

APPLICATION HINTS (Continued)

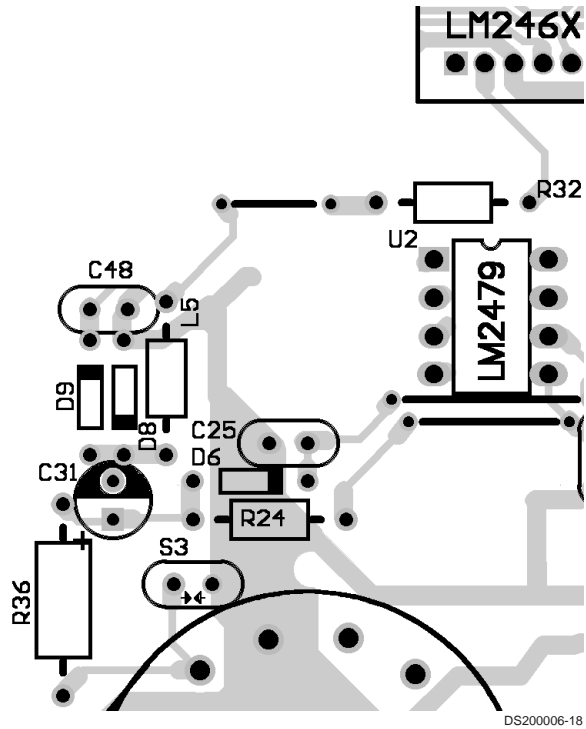
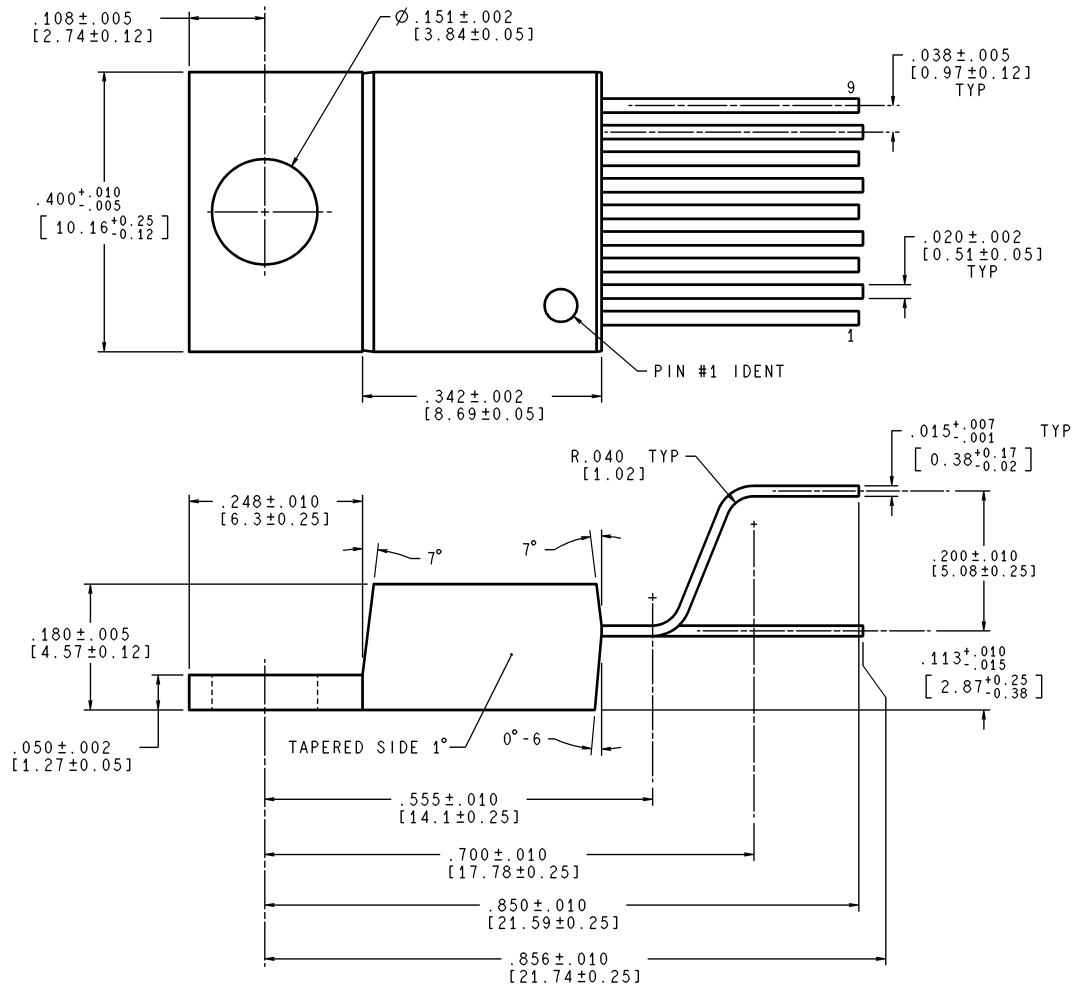

FIGURE 8. Trace Routing and Component Placement for Blue Channel Video Output.

LM2469 Monolithic Triple 9nS High Gain CRT Driver

Physical Dimensions inches (millimeters) unless otherwise noted



CONTROLLING DIMENSION IS INCH
VALUES IN [] ARE MILLIMETERS

TA09A (Rev C)

Note: Information contained in this data sheet is preliminary and may be subject to change without notice.

NS Package Number TA09A
Order Number LM2469TA

LIFE SUPPORT POLICY

NATIONAL'S PRODUCTS ARE NOT AUTHORIZED FOR USE AS CRITICAL COMPONENTS IN LIFE SUPPORT DEVICES OR SYSTEMS WITHOUT THE EXPRESS WRITTEN APPROVAL OF THE PRESIDENT AND GENERAL COUNSEL OF NATIONAL SEMICONDUCTOR CORPORATION. As used herein:

1. Life support devices or systems are devices or systems which, (a) are intended for surgical implant into the body, or (b) support or sustain life, and whose failure to perform when properly used in accordance with instructions for use provided in the labeling, can be reasonably expected to result in a significant injury to the user.
2. A critical component is any component of a life support device or system whose failure to perform can be reasonably expected to cause the failure of the life support device or system, or to affect its safety or effectiveness.

 **National Semiconductor Corporation**
Americas
Tel: 1-800-272-9959
Fax: 1-800-737-7018
Email: support@nsc.com
www.national.com

National Semiconductor Europe
Fax: +49 (0) 180-530 85 86
Email: europe.support@nsc.com
Deutsch Tel: +49 (0) 69 9508 6208
English Tel: +44 (0) 870 24 0 2171
Français Tel: +33 (0) 1 41 91 8790

National Semiconductor Asia Pacific Customer Response Group
Tel: 65-2544466
Fax: 65-2504466
Email: ap.support@nsc.com

National Semiconductor Japan Ltd.
Tel: 81-3-5639-7560
Fax: 81-3-5639-7507