

DATA SHEET

74LVC646A

Octal bus transceiver/register (3-State)

Product specification
Supersedes data of 1998 Mar 25
IC24 Data Handbook

1998 Jul 29

Octal bus transceiver/register (3-State)

74LVC646A

FEATURES

- Wide supply voltage range of 1.2V to 3.6V
- Flow-through pin-out architecture
- In accordance with JEDEC standard no. 8-1A
- CMOS low power consumption
- Direct interface with TTL levels
- 5 Volt tolerant inputs/outputs, for interfacing with 5 Volt logic

DESCRIPTION

The 74LVC646A is a high performance, low-power, low-voltage Si-gate CMOS device, superior to most advanced CMOS compatible TTL families.

Inputs can be driven from either 3.3V or 5.0V devices. In 3-State operation, outputs can handle 5V. This feature allows the use of these devices as translators in a mixed 3.3V/5V environment.

The 74LVC646A consist of non-inverting bus transceiver circuits with 3-State outputs, D-type flip-flops and control circuitry arranged

for multiplexed transmission of data directly from the internal registers. Data on the 'A' or 'B' bus will be clocked in the internal registers, as the appropriate clock (CPAB or CPBA) goes to a HIGH logic level. Output enable (\overline{OE}) and direction (DIR) inputs are provided to control the transceiver function. In the transceiver mode, data present at the high-impedance port may be stored in either the 'A' or 'B' register, or in both. The select source inputs (SAB and SBA) can multiplex stored and real-time (transparent mode) data.

The direction (DIR) input determines which bus will receive data when \overline{OE} is active (LOW). In the isolation mode (OE = HIGH), 'A' data may be stored in the 'B' register and/or 'B' data may be stored in the 'A' register.

When an output function is disabled, the input function is still enabled and may be used to store and transmit data. Only one of the two buses, 'A' or 'B' may be driven at a time.

The '646A' is functionally identical to the '648A' but has non-inverting data paths.

QUICK REFERENCE DATA

GND = 0V; $T_{amb} = 25^{\circ}\text{C}$; $t_r = t_f \leq 2.5 \text{ ns}$

SYMBOL	PARAMETER	CONDITIONS	TYPICAL	UNIT
t_{PHL}/t_{PLH}	Propagation delay An to Yn	$C_L = 50\text{pF}$ $V_{CC} = 3.3\text{V}$	3.9	ns
f_{max}	Maximum clock frequency		250	MHz
C_I	Input capacitance		5.0	pF
$C_{I/O}$	Input/output capacitance		10	pF
C_{PD}	Power dissipation capacitance per gate	Notes 1, 2	26	pF

NOTES:

1. C_{PD} is used to determine the dynamic power dissipation (P_D in μW)
 $P_D = C_{PD} \times V_{CC}^2 \times f_i + \Sigma (C_L \times V_{CC}^2 \times f_o)$ where:
 f_i = input frequency in MHz; C_L = output load capacitance in pF;
 f_o = output frequency in MHz; V_{CC} = supply voltage in V;
 $\Sigma (C_L \times V_{CC}^2 \times f_o)$ = sum of the outputs.
2. The condition is $V_I = \text{GND to } V_{CC}$.

ORDERING AND PACKAGE INFORMATION

PACKAGES	TEMPERATURE RANGE	OUTSIDE NORTH AMERICA	NORTH AMERICA	PKG. DWG. #
24-Pin Plastic SO	-40°C to +85°C	74LVC646A D	74LVC646A D	SOT137-1
24-Pin Plastic SSOP Type II	-40°C to +85°C	74LVC646A DB	74LVC646A DB	SOT340-1
24-Pin Plastic TSSOP Type I	-40°C to +85°C	74LVC646A PW	7LVC646APW DH	SOT355-1

Octal bus transceiver/register (3-State)

74LVC646A

PIN CONFIGURATION

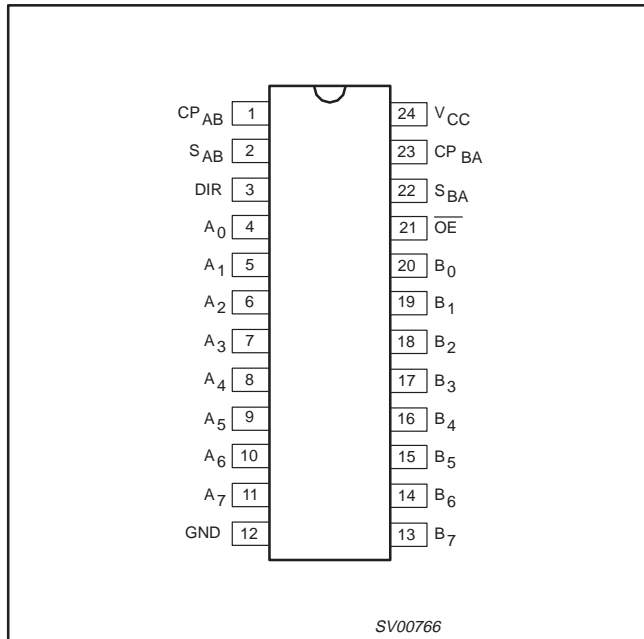

PIN DESCRIPTION

PIN NUMBER	SYMBOL	FUNCTION
1	CP _{AB}	'A' to 'B' clock input (LOW-to-HIGH, edge-triggered)
2	S _{AB}	Select 'A' to 'B' source input
3	DIR	Direction control input
4, 5, 6, 7, 8, 9, 10, 11	A ₀ to A ₇	'A' data inputs/outputs
12	GND	Ground (0V)
20, 19, 18, 17, 16, 15, 14, 13	B ₀ to B ₇	'B' data inputs/outputs
21	\overline{OE}	Output enable input (active LOW)
22	S _{BA}	Select 'B' to 'A' source input
23	CP _{BA}	'B' to 'A' clock input (LOW-to-HIGH, edge-triggered)
24	V _{CC}	Positive supply voltage

FUNCTION TABLE

INPUTS						DATA I/O *		FUNCTION
\overline{OE}	DIR	CP _{AB}	CP _{BA}	S _{AB}	S _{BA}	A ₀ to A ₇	B ₀ to B ₇	
X	X	↑	X	X	X	input	un *	store A, B unspecified *
X	X	X	↑	X	X	un *	input	store B, A unspecified *
H	X	↑	↑	X	X	input	input	store A and B data, isolation hold storage
H	X	H or L	H or L	X	X	input	input	store A and B data, isolation hold storage
L	L	X	X	X	L	output	input	real-time B data to A bus
L	L	X	H or L	X	H	output	input	stored B data to A bus
L	H	X	X	L	X	input	output	real-time A data to B bus
L	H	H or L	X	H	X	input	output	stored A data to B bus

* The data output functions may be enabled or disabled by various signals at the \overline{OE} and DIR inputs. Data input functions are always enabled, i.e., data at the bus inputs will be stored on every LOW-to-HIGH transition on the clock inputs.

- un = unspecified
- H = HIGH voltage level
- L = LOW voltage level
- X = Don't care
- ↑ = LOW-to-HIGH level transition

Octal bus transceiver/register (3-State)

74LVC646A

LOGIC SYMBOL

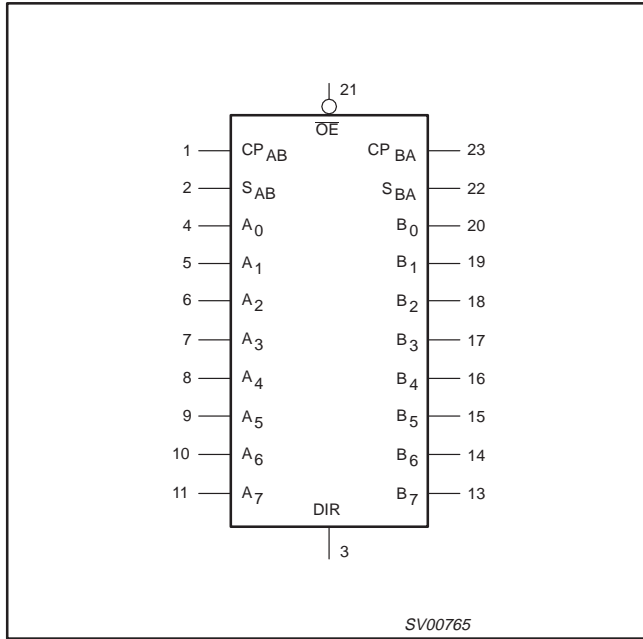

FUNCTIONAL DIAGRAM

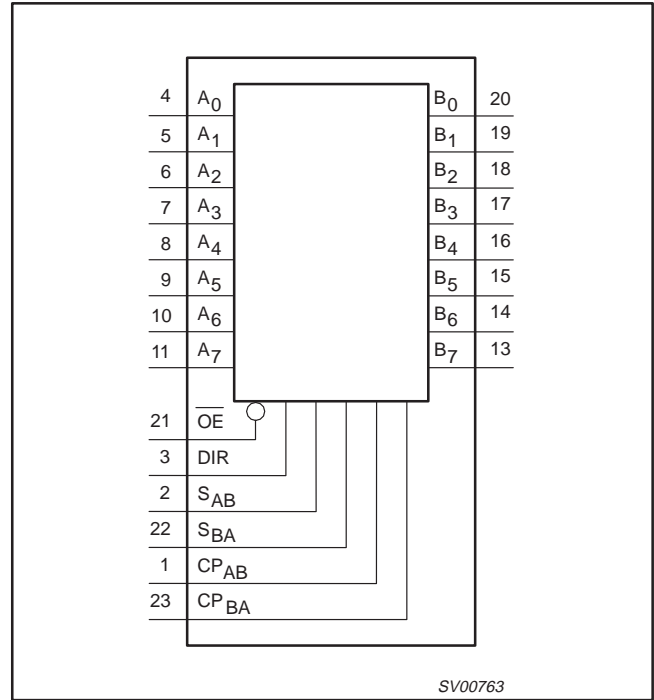

LOGIC SYMBOL (IEEE/IEC)

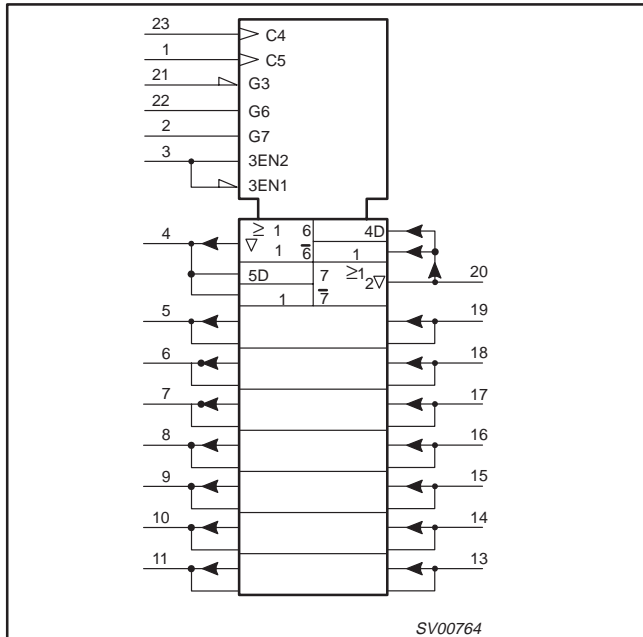

Octal bus transceiver/register (3-State)

74LVC646A

LOGIC DIAGRAM

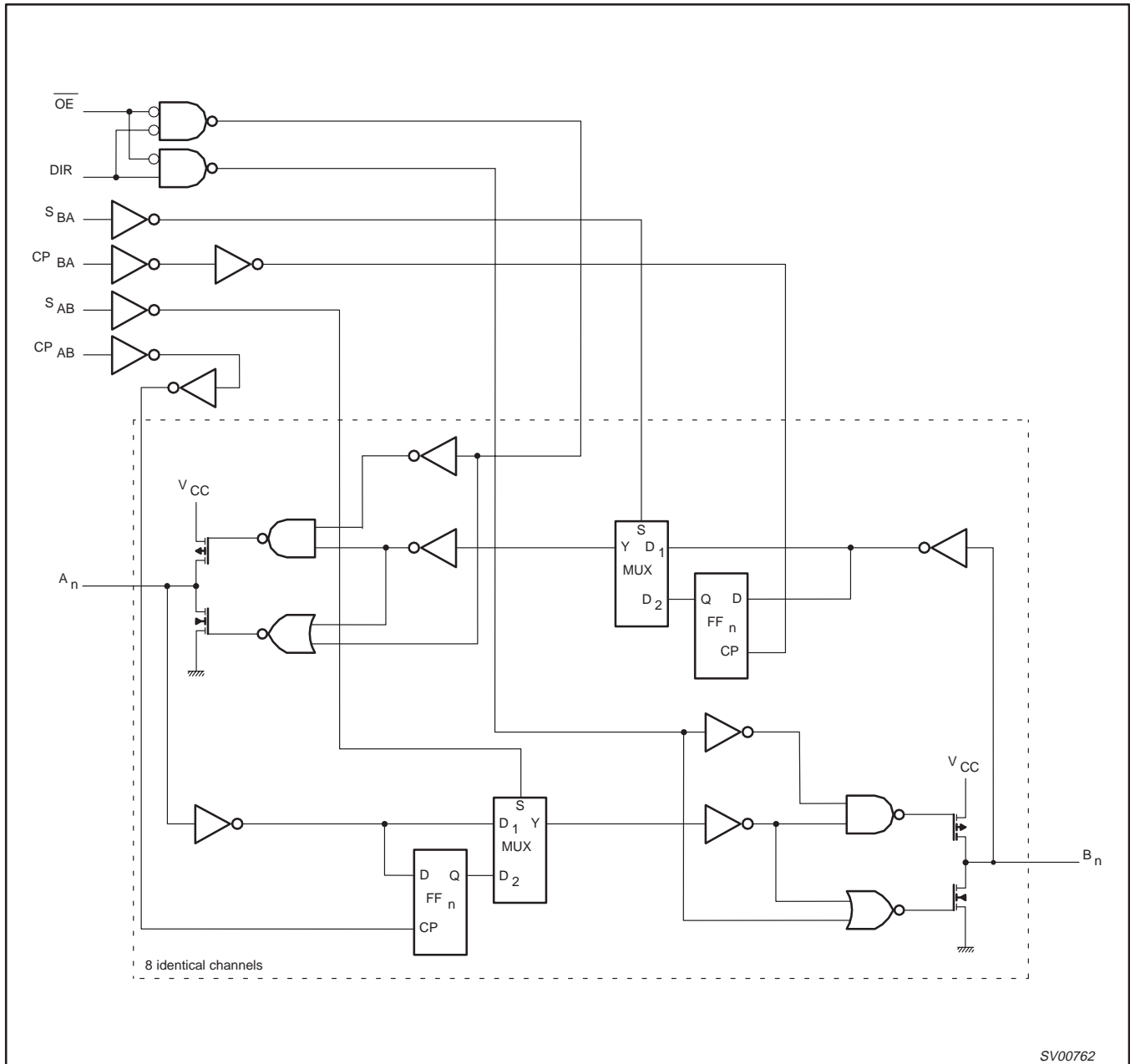

Octal bus transceiver/register (3-State)

74LVC646A

RECOMMENDED OPERATING CONDITIONS

SYMBOL	PARAMETER	CONDITIONS	LIMITS		UNIT
			MIN	MAX	
V_{CC}	DC supply voltage (for max. speed performance)		2.7	3.6	V
	DC supply voltage (for low-voltage applications)		1.2	3.6	
V_I	DC input voltage range		0	5.5	V
V_O	DC output voltage range; output HIGH or LOW state		0	V_{CC}	V
	DC output voltage range; output 3-State		0	5.5	
T_{amb}	Operating free-air temperature range		-40	+85	°C
t_r, t_f	Input rise and fall times	$V_{CC} = 1.2$ to $2.7V$ $V_{CC} = 2.7$ to $3.6V$	0	20 10	ns/V

ABSOLUTE MAXIMUM RATINGS¹

In accordance with the Absolute Maximum Rating System (IEC 134)
 Voltages are referenced to GND (ground = 0V)

SYMBOL	PARAMETER	CONDITIONS	RATING	UNIT
V_{CC}	DC supply voltage		-0.5 to +6.5	V
I_{IK}	DC input diode current	$V_I < 0$	-50	mA
V_I	DC input voltage	Note 2	-0.5 to +6.5	V
I_{OK}	DC output diode current	$V_O > V_{CC}$ or $V_O < 0$	±50	mA
V_O	DC output voltage; output HIGH or LOW	Note 2	-0.5 to $V_{CC} + 0.5$	V
	DC output voltage; output 3-State	Note 2	-0.5 to 6.5	
I_O	DC output diode current	$V_O = 0$ to V_{CC}	±50	mA
I_{GND}, I_{CC}	DC V_{CC} or GND current		±100	mA
T_{stg}	Storage temperature range		-65 to +150	°C
P_{TOT}	Power dissipation per package – plastic mini-pack (SO)	above +70°C derate linearly with 8 mW/K	500	mW
	– plastic shrink mini-pack (SSOP and TSSOP)	above +60°C derate linearly with 5.5 mW/K	500	

NOTES:

- Stresses beyond those listed may cause permanent damage to the device. These are stress ratings only and functional operation of the device at these or any other conditions beyond those indicated under "recommended operating conditions" is not implied. Exposure to absolute-maximum-rated conditions for extended periods may affect device reliability.
- The input and output voltage ratings may be exceeded if the input and output current ratings are observed.

Octal bus transceiver/register (3-State)

74LVC646A

DC ELECTRICAL CHARACTERISTICS

Over recommended operating conditions voltages are referenced to GND (ground = 0V)

SYMBOL	PARAMETER	TEST CONDITIONS	LIMITS			UNIT	
			Temp = -40°C to +85°C				
			MIN	TYP ¹	MAX		
V _{IH}	HIGH level Input voltage	V _{CC} = 1.2V	V _{CC}			V	
		V _{CC} = 2.7 to 3.6V	2.0				
V _{IL}	LOW level Input voltage	V _{CC} = 1.2V			GND	V	
		V _{CC} = 2.7 to 3.6V			0.8		
V _{OH}	HIGH level output voltage	V _{CC} = 2.7V; V _I = V _{IH} or V _{IL} ; I _O = -12mA	V _{CC} - 0.5			V	
		V _{CC} = 3.0V; V _I = V _{IH} or V _{IL} ; I _O = -100µA	V _{CC} - 0.2	V _{CC}			
		V _{CC} = 3.0V; V _I = V _{IH} or V _{IL} ; I _O = -18mA	V _{CC} - 0.6				
		V _{CC} = 3.0V; V _I = V _{IH} or V _{IL} ; I _O = -24mA	V _{CC} - 0.8				
V _{OL}	LOW level output voltage	V _{CC} = 2.7V; V _I = V _{IH} or V _{IL} ; I _O = 12mA			0.40	V	
		V _{CC} = 3.0V; V _I = V _{IH} or V _{IL} ; I _O = 100µA		GND	0.20		
		V _{CC} = 3.0V; V _I = V _{IH} or V _{IL} ; I _O = 24mA			0.55		
I _I	Input leakage current	V _{CC} = 3.6V; V _I = 5.5V or GND	Not for I/O pins		± 0.1	± 5	µA
I _{IHZ} /I _{ILZ}	Input current for common I/O pins	V _{CC} = 3.6V; V _I = V _{CC} or GND			± 0.1	± 15	µA
I _{OZ}	3-State output OFF-state current	V _{CC} = 3.6V; V _I = V _{IH} or V _{IL} ; V _O = 5.5V or GND			0.1	± 10	µA
I _{OFF}	Power off leakage current	V _{CC} = 0.0V; V _I or V _O = 5.5V			0.1	± 10	µA
I _{CC}	Quiescent supply current	V _{CC} = 3.6V; V _I = V _{CC} or GND; I _O = 0			0.1	10	µA
ΔI _{CC}	Additional quiescent supply current per input pin	V _{CC} = 2.7V to 3.6V; V _I = V _{CC} - 0.6V; I _O = 0			5	500	µA

NOTES:1. All typical values are at V_{CC} = 3.3V and T_{amb} = 25°C.

Octal bus transceiver/register (3-State)

74LVC646A

AC CHARACTERISTICSGND = 0 V; $t_r = t_f \leq 2.5$ ns; $C_L = 50$ pF

SYMBOL	PARAMETER	WAVEFORM	LIMITS						UNIT
			$V_{CC} = 3.3V \pm 0.3V$			$V_{CC} = 2.7V$		$V_{CC} = 1.2V$	
			MIN	TYP ¹	MAX	MIN	MAX	TYP	
t_{PHL}/t_{PLH}	Propagation delay An, Bn to Bn, An	Figures 1, 6	1.5	3.9	6.8	1.5	7.8	15	ns
t_{PHL}/t_{PLH}	Propagation delay $\overline{CP_{AB}}$, CP_{BA} to Bn, An	Figures 2, 6	1.5	4.6	7.6	1.5	8.6	19	ns
t_{PHL}/t_{PLH}	Propagation delay S_{AB} , S_{BA} to Bn, An	Figures 3, 6	1.5	4.9	8.5	1.5	9.5	19	ns
t_{PZH}/t_{PZL}	3-State output enable time \overline{OEn} to An, Bn	Figures 4, 6	1.5	4.5	7.8	1.5	8.8	20	ns
t_{PHZ}/t_{PLZ}	3-State output disable time \overline{OEn} to An, Bn	Figures 4, 6	1.5	3.9	6.1	1.5	7.1	10	ns
t_{PZH}/t_{PZL}	3-State output enable time DIR to An, Bn	Figures 5, 6	1.5	4.6	7.9	1.5	8.9	20	ns
t_{PHZ}/t_{PLZ}	3-State output disable time DIR to An, Bn	Figures 5, 6	1.5	3.5	6.0	1.5	7.0	12	ns
t_W	Clock pulse width HIGH or LOW CP_{AB} or CP_{BA}	Figure 1, 3	3.3	1.9	–	3.3	–	–	ns
t_{su}	Set-up time An, Bn to CP_{AB} , CP_{BA}	Figure 2	1.6	0.35	–	1.6	–	–	ns
t_h	Hold time An, Bn to CP_{AB} , CP_{BA}	Figure 2	1.0	–0.3	–	1.0	–	–	ns
f_{max}	Maximum clock pulse frequency	Figure 2	150	250	–	125	–	–	ns

NOTE:1. These typical values are at $V_{CC} = 3.3V$ and $T_{amb} = 25^\circ C$.

Octal bus transceiver/register (3-State)

74LVC646A

AC WAVEFORMS

$V_M = 1.5V$ at $V_{CC} \geq 2.7V$
 $V_M = 0.5V * V_{CC}$ at $V_{CC} < 2.7V$
 V_{OL} and V_{OH} are the typical output voltage drop that occur with the output load.
 $V_X = V_{OL} + 0.3V$ at $V_{CC} \geq 2.7V$
 $V_X = V_{OL} + 0.1V_{CC}$ at $V_{CC} < 2.7V$
 $V_Y = V_{OH} - 0.3V$ at $V_{CC} \geq 2.7V$
 $V_Y = V_{OH} - 0.1V_{CC}$ at $V_{CC} < 2.7V$

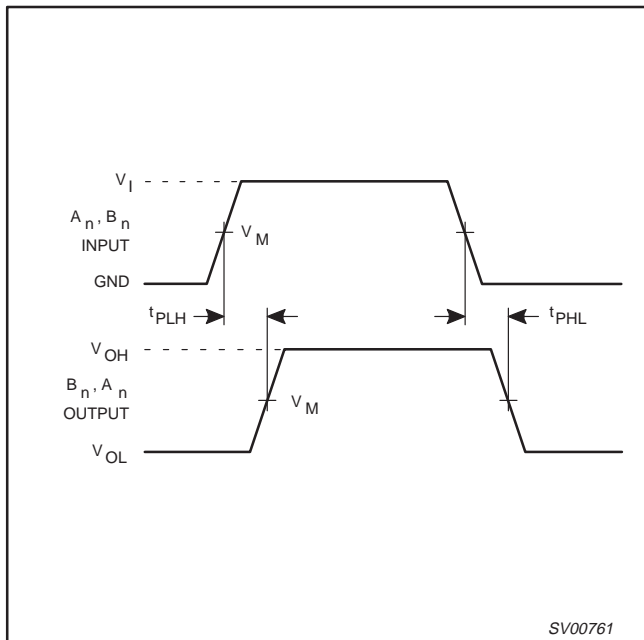

Figure 1. Input A_n, B_n to output B_n, A_n propagation delays.

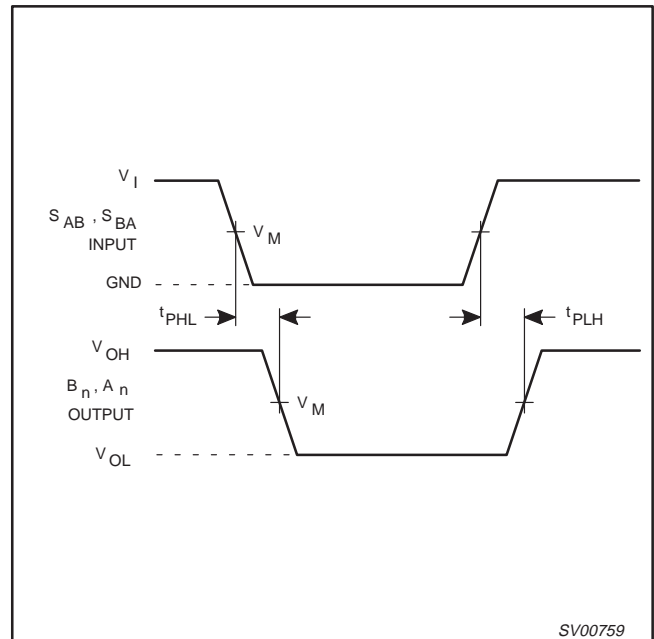

Figure 3. Input S_{AB}, S_{BA} to output B_n, A_n propagation delay times.

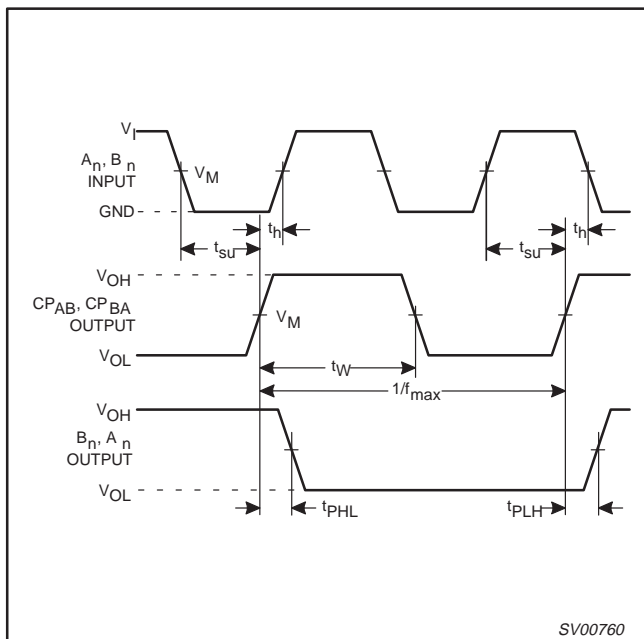

Figure 2. A_n, B_n to CP_{AB}, CP_{BA} set-up and hold times, clock CP_{AB}, CP_{BA} pulse width, maximum clock pulse frequency and the CP_{AB}, CP_{BA} to output B_n, A_n propagation delays.

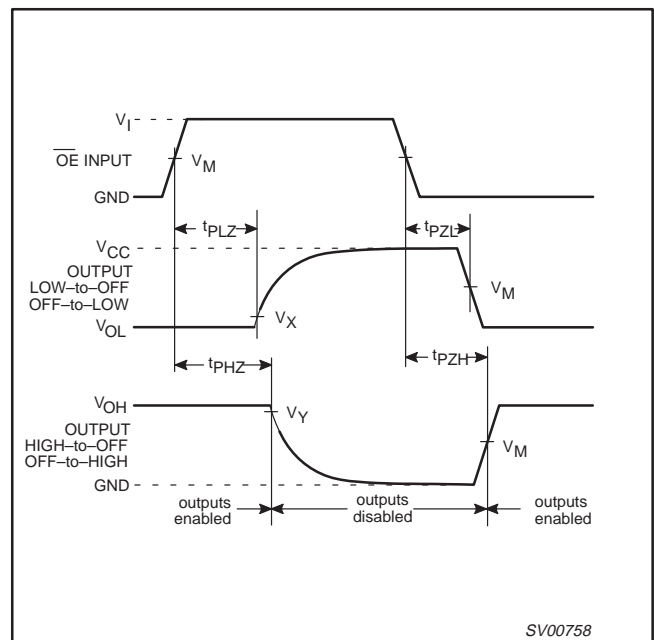

Figure 4. Input OE to output A_n, B_n 3-State enable and disable times.

Octal bus transceiver/register (3-State)

74LVC646A

AC WAVEFORMS (Continued)

$V_M = 1.5V$ at $V_{CC} \geq 2.7V$

$V_M = 0.5V * V_{CC}$ at $V_{CC} < 2.7V$

V_{OL} and V_{OH} are the typical output voltage drop that occur with the output load.

$V_X = V_{OL} + 0.3V$ at $V_{CC} \geq 2.7V$

$V_X = V_{OL} + 0.1V_{CC}$ at $V_{CC} < 2.7V$

$V_Y = V_{OH} - 0.3V$ at $V_{CC} \geq 2.7V$

$V_Y = V_{OH} - 0.1V_{CC}$ at $V_{CC} < 2.7V$

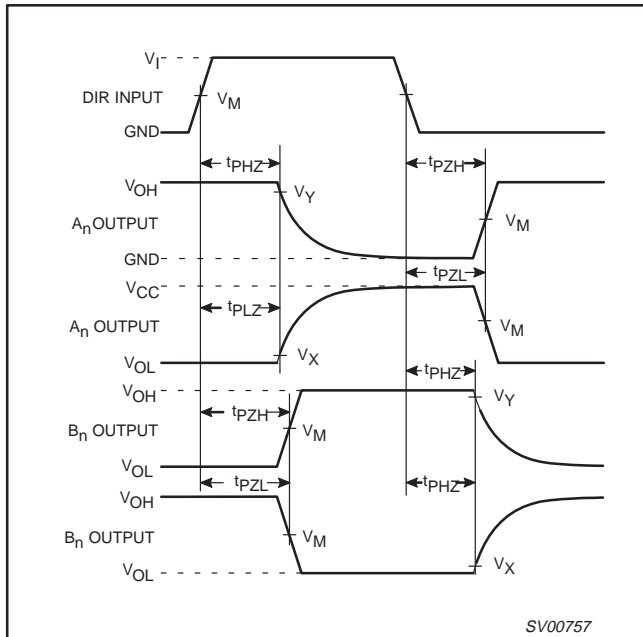

Figure 5. Input DIR to output A_n, B_n 3-State enable and disable times.

TEST CIRCUIT

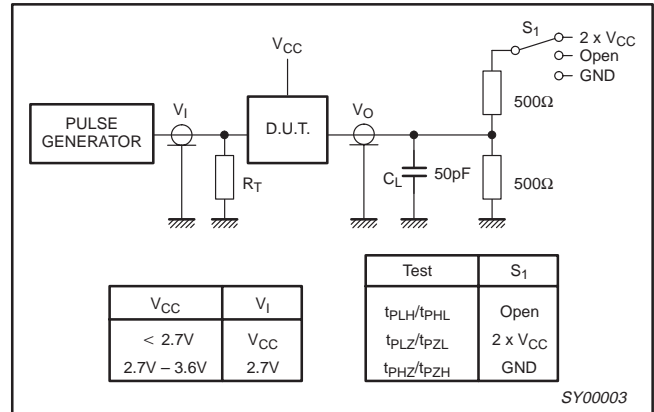

Figure 6. Load circuitry for switching times.

Octal bus transceiver/register (3-State)

74LVC646A

APPLICATION INFORMATION

Real-time transfer; bus B to bus A

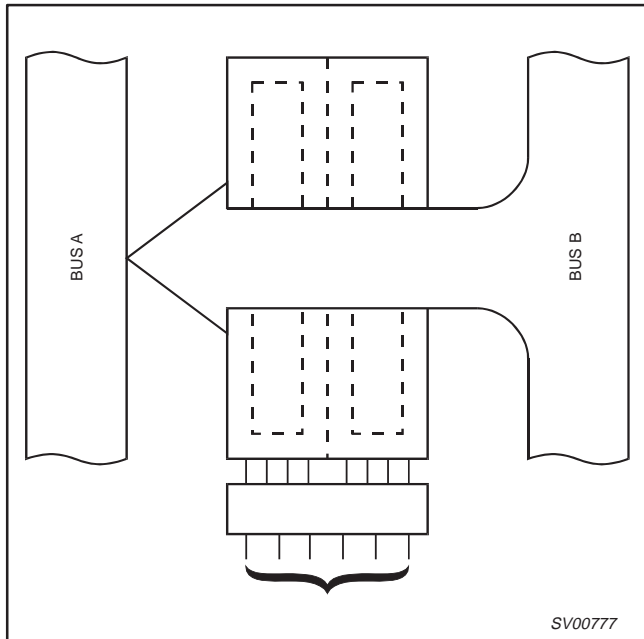

(1)	(14)	(28)	(16)	(27)	(15)
\overline{OE}	DIR	CP _{AB}	CP _{BA}	S _{AB}	S _{BA}
L	L	X	X	X	L

Real-time transfer; bus A to bus B

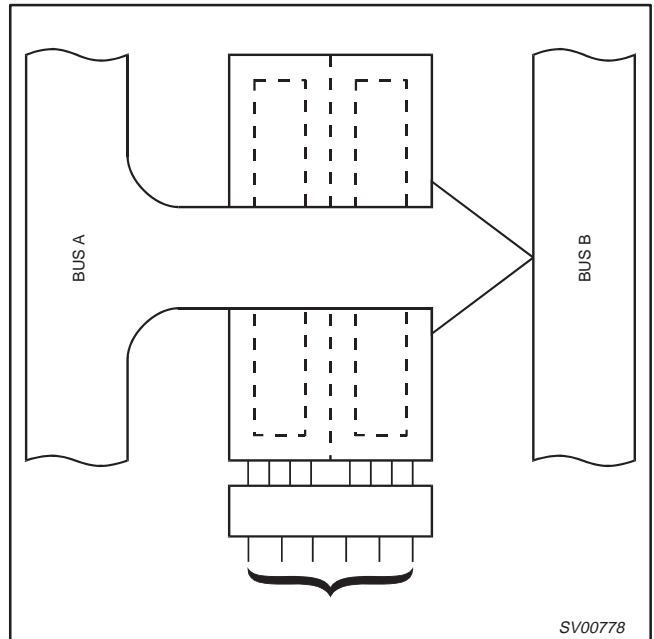

(1)	(14)	(28)	(16)	(27)	(15)
\overline{OE}	DIR	CP _{AB}	CP _{BA}	S _{AB}	S _{BA}
L	H	X	X	L	X

Storage from A, B or A and B

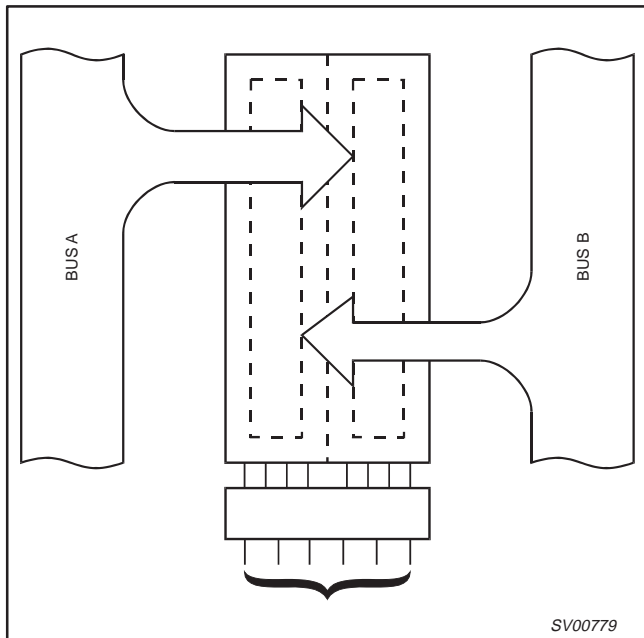

(1)	(14)	(28)	(16)	(27)	(15)
\overline{OE}	DIR	CP _{AB}	CP _{BA}	S _{AB}	S _{BA}
X	X	↑	X	X	X
X	X	X	↑	X	L
H	X	↑	↑	X	X

Transfer storage data to A or B

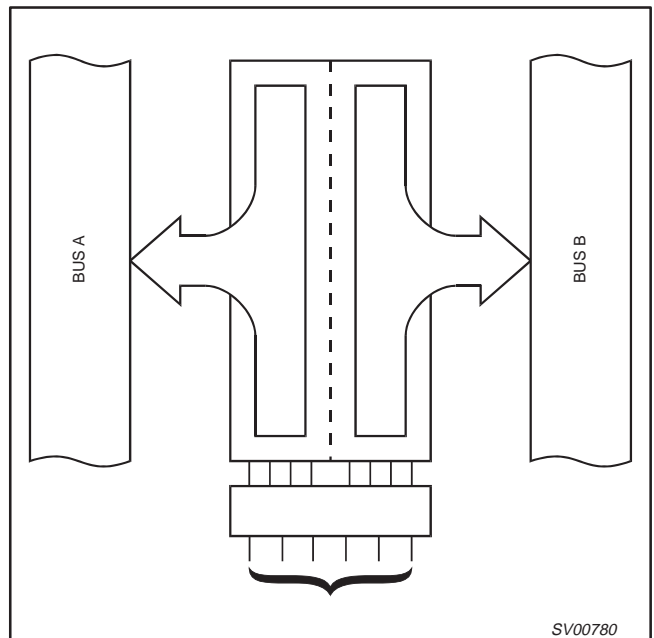

(1)	(14)	(28)	(16)	(27)	(15)
\overline{OE}	DIR	CP _{AB}	CP _{BA}	S _{AB}	S _{BA}
L	L	X	H or L	X	H
L	H	H or L	X	H	X

Octal bus transceiver/register (3-State)

74LVC646A

SO20: plastic small outline package; 20 leads; body width 7.5 mm

SOT163-1

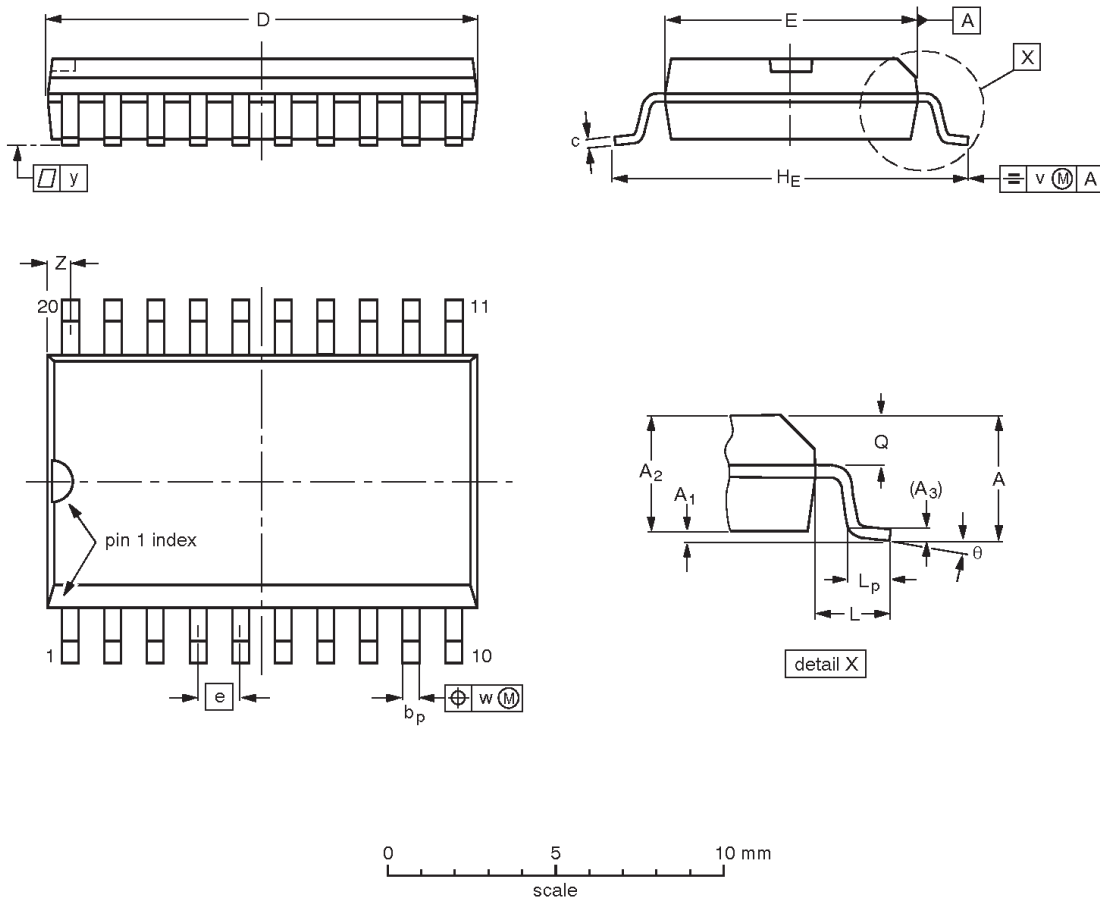

DIMENSIONS (inch dimensions are derived from the original mm dimensions)

UNIT	A max.	A ₁	A ₂	A ₃	b _p	c	D ⁽¹⁾	E ⁽¹⁾	e	HE	L	L _p	Q	v	w	y	Z ⁽¹⁾	θ
mm	2.65 0.10	0.30 2.25	2.45 0.089	0.25	0.49 0.36	0.32 0.23	13.0 12.6	7.6 7.4	1.27	10.65 10.00	1.4	1.1 0.4	1.1 1.0	0.25	0.25	0.1	0.9 0.4	8° 0°
inches	0.10	0.012 0.004	0.096 0.089	0.01	0.019 0.014	0.013 0.009	0.51 0.49	0.30 0.29	0.050	0.42 0.39	0.055	0.043 0.016	0.043 0.039	0.01	0.01	0.004	0.035 0.016	

Note

1. Plastic or metal protrusions of 0.15 mm maximum per side are not included.

OUTLINE VERSION	REFERENCES			EUROPEAN PROJECTION	ISSUE DATE
	IEC	JEDEC	EIAJ		
SOT163-1	075E04	MS-013AC			-92-11-17 95-01-24

Octal bus transceiver/register (3-State)

74LVC646A

SSOP20: plastic shrink small outline package; 20 leads; body width 5.3 mm

SOT339-1

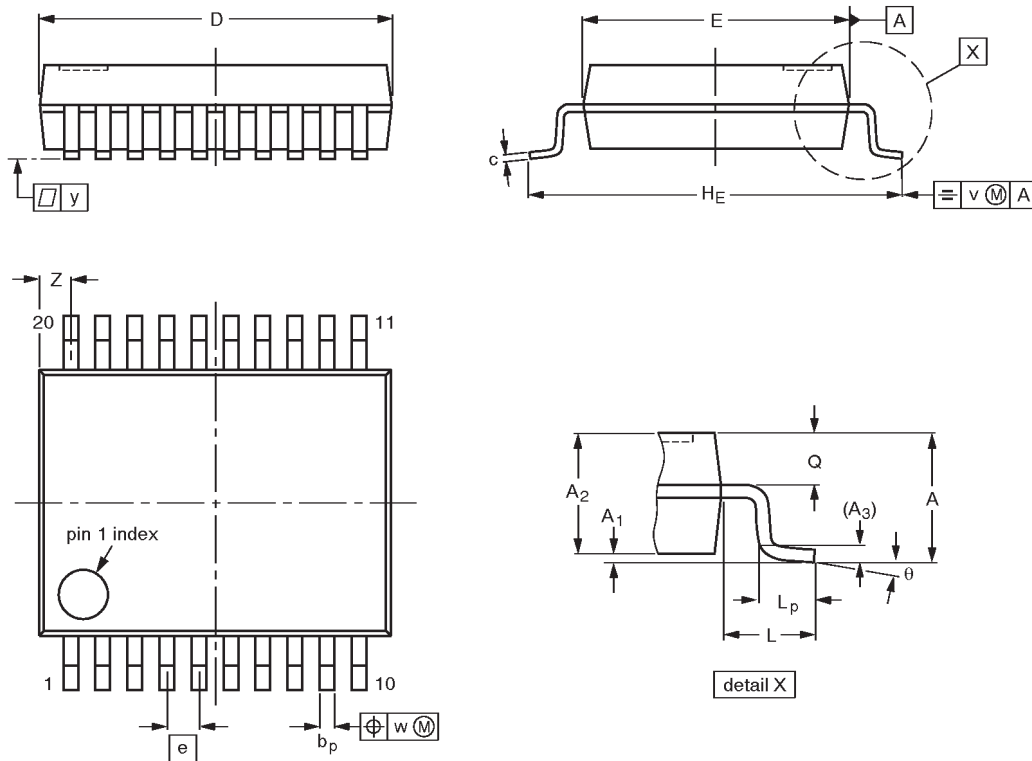

DIMENSIONS (mm are the original dimensions)

UNIT	A max.	A ₁	A ₂	A ₃	b _p	c	D ⁽¹⁾	E ⁽¹⁾	e	H _E	L	L _p	Q	v	w	y	Z ⁽¹⁾	θ
mm	2.0	0.21 0.05	1.80 1.65	0.25	0.38 0.25	0.20 0.09	7.4 7.0	5.4 5.2	0.65	7.9 7.6	1.25	1.03 0.63	0.9 0.7	0.2	0.13	0.1	0.9 0.5	8° 0°

Note

1. Plastic or metal protrusions of 0.20 mm maximum per side are not included.

OUTLINE VERSION	REFERENCES				EUROPEAN PROJECTION	ISSUE DATE
	IEC	JEDEC	EIAJ			
SOT339-1		MO-150AE				93-09-08 95-02-04

Octal bus transceiver/register (3-State)

74LVC646A

TSSOP20: plastic thin shrink small outline package; 20 leads; body width 4.4 mm

SOT360-1

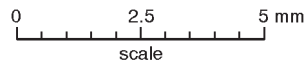
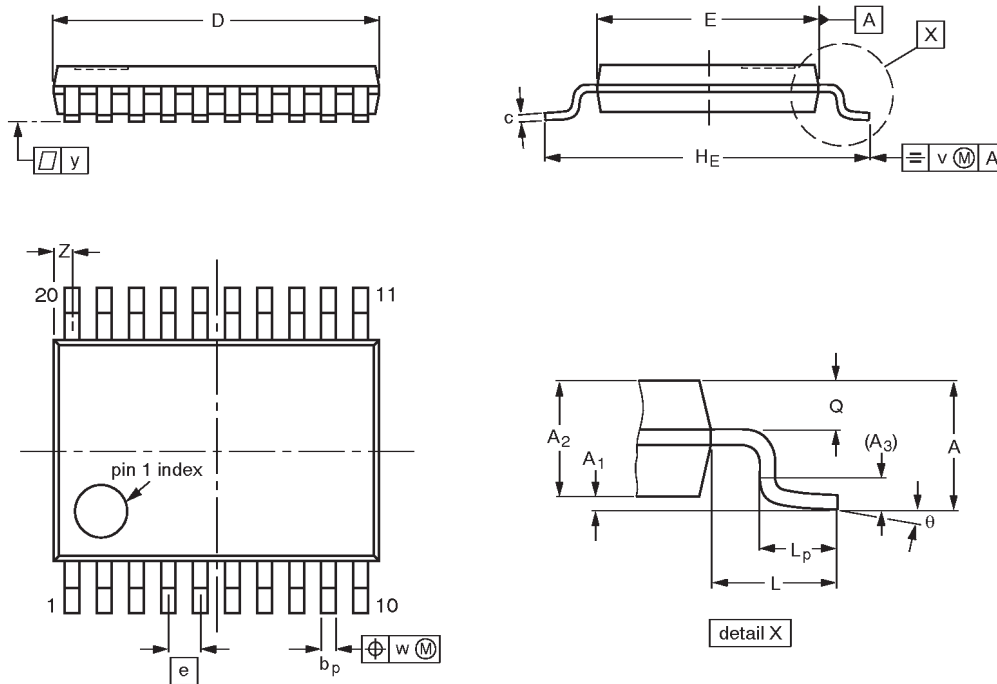

DIMENSIONS (mm are the original dimensions)

UNIT	A max.	A ₁	A ₂	A ₃	b _p	c	D ⁽¹⁾	E ⁽²⁾	e	H _E	L	L _p	Q	v	w	y	Z ⁽¹⁾	θ
mm	1.10	0.15 0.05	0.95 0.80	0.25	0.30 0.19	0.2 0.1	6.6 6.4	4.5 4.3	0.65	6.6 6.2	1.0	0.75 0.50	0.4 0.3	0.2	0.13	0.1	0.5 0.2	8° 0°

Notes

1. Plastic or metal protrusions of 0.15 mm maximum per side are not included.
2. Plastic interlead protrusions of 0.25 mm maximum per side are not included.

OUTLINE VERSION	REFERENCES				EUROPEAN PROJECTION	ISSUE DATE
	IEC	JEDEC	EIAJ			
SOT360-1		MO-153AC				93-06-16 95-02-04

Octal bus transceiver/register (3-State)

74LVC646A

NOTES

Octal bus transceiver/register (3-State)

74LVC646A

Data sheet status

Data sheet status	Product status	Definition [1]
Objective specification	Development	This data sheet contains the design target or goal specifications for product development. Specification may change in any manner without notice.
Preliminary specification	Qualification	This data sheet contains preliminary data, and supplementary data will be published at a later date. Philips Semiconductors reserves the right to make changes at any time without notice in order to improve design and supply the best possible product.
Product specification	Production	This data sheet contains final specifications. Philips Semiconductors reserves the right to make changes at any time without notice in order to improve design and supply the best possible product.

[1] Please consult the most recently issued datasheet before initiating or completing a design.

Definitions

Short-form specification — The data in a short-form specification is extracted from a full data sheet with the same type number and title. For detailed information see the relevant data sheet or data handbook.

Limiting values definition — Limiting values given are in accordance with the Absolute Maximum Rating System (IEC 134). Stress above one or more of the limiting values may cause permanent damage to the device. These are stress ratings only and operation of the device at these or at any other conditions above those given in the Characteristics sections of the specification is not implied. Exposure to limiting values for extended periods may affect device reliability.

Application information — Applications that are described herein for any of these products are for illustrative purposes only. Philips Semiconductors make no representation or warranty that such applications will be suitable for the specified use without further testing or modification.

Disclaimers

Life support — These products are not designed for use in life support appliances, devices or systems where malfunction of these products can reasonably be expected to result in personal injury. Philips Semiconductors customers using or selling these products for use in such applications do so at their own risk and agree to fully indemnify Philips Semiconductors for any damages resulting from such application.

Right to make changes — Philips Semiconductors reserves the right to make changes, without notice, in the products, including circuits, standard cells, and/or software, described or contained herein in order to improve design and/or performance. Philips Semiconductors assumes no responsibility or liability for the use of any of these products, conveys no license or title under any patent, copyright, or mask work right to these products, and makes no representations or warranties that these products are free from patent, copyright, or mask work right infringement, unless otherwise specified.

Philips Semiconductors
811 East Arques Avenue
P.O. Box 3409
Sunnyvale, California 94088-3409
Telephone 800-234-7381

© Copyright Philips Electronics North America Corporation 1998
All rights reserved. Printed in U.S.A.

print code

Date of release: 08-98

Document order number:

9397-750-04516

Let's make things better.