



High-Accuracy PWM Output Temperature Sensors

General Description

The MAX6666/MAX6667 are high-accuracy, low-cost, low-power temperature sensors with a single-wire output. The MAX6666/MAX6667 convert the ambient temperature into a ratiometric PWM output with temperature information contained in the duty cycle of the output square wave. The MAX6666 has a push-pull output and the MAX6667 has an open-drain output.

The MAX6666/MAX6667 operate at supply voltages from +3V to +5.5V. The typical unloaded supply current at 5.0V is 200µA. Both devices feature a single-wire output that minimizes the number of pins necessary to interface with a microprocessor (µP). The output is a square wave with a nominal frequency of 35Hz (±20%) at +25°C. The output format is decoded as follows:

$$\text{Temperature (°C)} = 235 - (400 \times t_1) / t_2$$

Where t_1 is fixed with a typical value of 10ms and t_2 is modulated by the temperature (Figure 1). The MAX6666/MAX6667 operate from -40°C to +125°C and are available in space-saving SOT23 and µMAX packages.

Applications

- Process Control
- Industrial
- HVAC and Environmental Control
- Automotive
- µP and µC Temperature Monitoring

Typical Operating Circuit

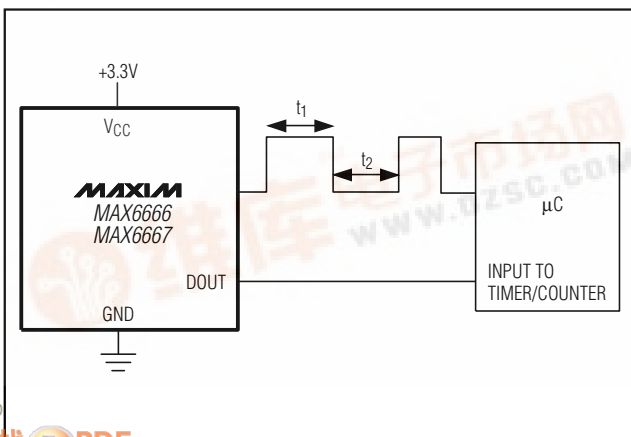

Features

- ◆ Simple Single-Wire PWM Output
- ◆ ±1.0°C Accuracy at +25°C
- ◆ High Accuracy
 - ±1°C at $T_A = +30^\circ\text{C}$
 - ±2.5°C at $T_A = +10^\circ\text{C}$ to $+50^\circ\text{C}$
- ◆ Operate Up to +125°C
- ◆ Low 200µA Typical Current Consumption
- ◆ Multiple Package Options
 - 6-Pin SOT23
 - 8-Pin SO
 - 8-Pin µMAX

Ordering Information

PART	TEMP RANGE	PIN-PACKAGE
MAX6666AUT-T	-40°C to +125°C	6 SOT23-6
MAX6666AUA	-40°C to +125°C	8 µMAX
MAX6666ASA	-40°C to +125°C	8 SO
MAX6667AUT-T	-40°C to +125°C	6 SOT23-6
MAX6667AUA	-40°C to +125°C	8 µMAX
MAX6667ASA	-40°C to +125°C	8 SO

Pin Configurations

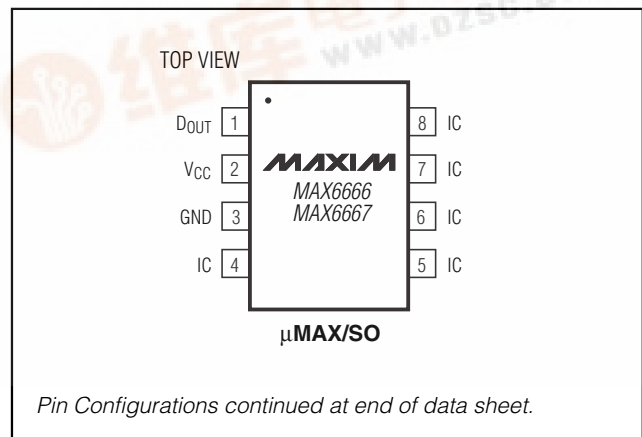

MAX6666/MAX6667

High-Accuracy PWM Output Temperature Sensors

ABSOLUTE MAXIMUM RATINGS

(Voltages Referenced to GND)

V _{CC}	-0.3V to +6.0V
D _{OUT}	
MAX6666	-0.3V to (V _{CC} + 0.3V)
MAX6667	-0.3V to + 6.0V
D _{OUT} Current	-1mA to +50mA
Continuous Current into Any Other Terminal	±20mA

Continuous Power Dissipation (T_A = +70°C)

6-Pin SOT23 (derate 8.7mW/°C above +70°C)	695.7mW
8-Pin μ MAX (derate 4.1mW/°C above +70°C)	330mW
8-Pin SO (derate 5.88mW/°C above +70°C)	471mW
Operating Temperature Range	-40°C to +150°C
Storage Temperature Range	-65°C to +150°C
Junction Temperature	+150°C
Lead Temperature (soldering, 10s)	+150°C

Stresses beyond those listed under "Absolute Maximum Ratings" may cause permanent damage to the device. These are stress ratings only, and functional operation of the device at these or any other conditions beyond those indicated in the operational sections of the specifications is not implied. Exposure to absolute maximum rating conditions for extended periods may affect device reliability.

ELECTRICAL CHARACTERISTICS

(V_{CC} = +3.0V to +5.5V, T_A = -40°C to +125°C, unless otherwise noted. Typical values are at V_{CC} = +3.3V, T_A = +25°C.)

PARAMETER	SYMBOL	CONDITIONS	MIN	TYP	MAX	UNITS
Supply Voltage Range	V _{CC}		3.0		5.5	V
Supply Current	I _{CC}	V _{CC} = +3.0V to +5.5V		200	500	μ A
Temperature Error		V _{CC} = +3.3V	T _A = +30°C	-1	+1	°C
			T _A = +10°C to +50°C	-2.5	+2.5	
			T _A = 0°C to +100°C	-3.8	+3.8	
			T _A = -25°C to +125°C	-4.8	+4.8	
			T _A = -40°C, V _{CC} = +3.3V	-6	+6	
Nominal t ₁ Pulse Width				10		ms
MAX6666 Output High Voltage		I _{OH} = 800 μ A	V _{CC} - 0.4			V
MAX6666 Output Low Voltage		I _{OL} = 800 μ A			0.4	V
MAX6666 Fall Time		C _L = 100pF, R _L = ∞		80		ns
MAX6666 Rise Time		C _L = 100pF, R _L = ∞		80		ns
MAX6667 Output Low Voltage		I _{SINK} = 1.6mA			0.4	V
		I _{SINK} = 5.0mA			1.2	
MAX6667 Fall Time		C _L = 100pF, R _L = 10k Ω		40		ns
MAX6667 Output Capacitance		C _L = 0		15		pF
MAX6667 Output Leakage				<0.1		μ A
Power-Supply Rejection Ratio	PSRR	V _{CC} = +3.0V to +5.5V		0.3	1.0	°C/V

High-Accuracy PWM Output Temperature Sensors

Typical Operating Characteristics

($V_{CC} = +3.3V$, $T_A = +25^\circ C$, unless otherwise noted.)

MAX6666/MAX6667

OUTPUT FREQUENCY vs. TEMPERATURE

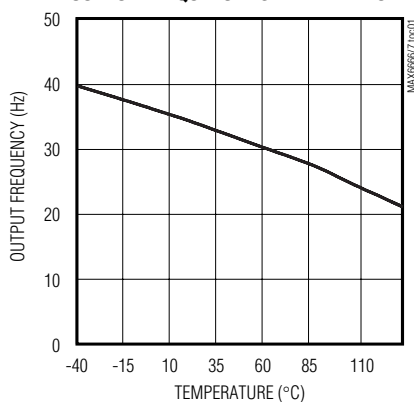

OUTPUT FREQUENCY vs. SUPPLY VOLTAGE

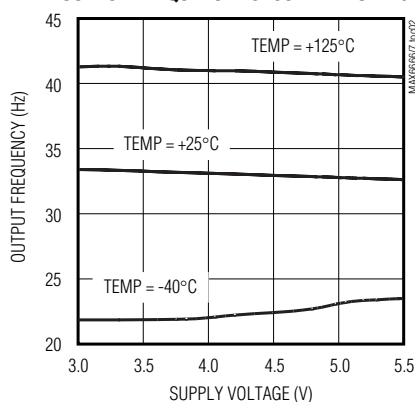

T₁ AND T₂ TIMES vs. TEMPERATURE

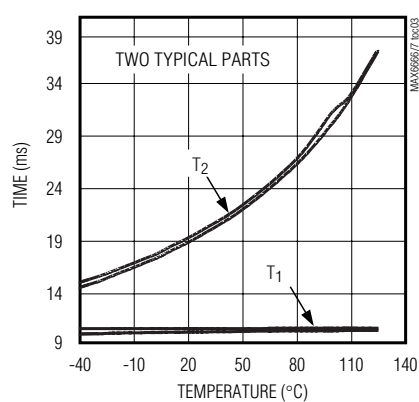

OUTPUT ACCURACY vs. TEMPERATURE

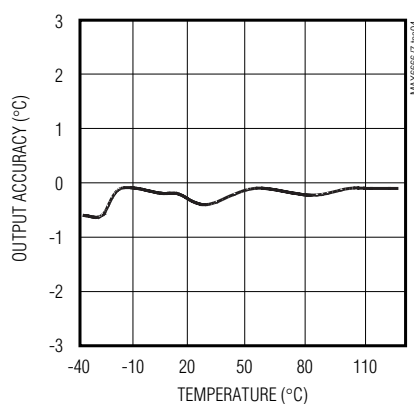

SUPPLY CURRENT vs. TEMPERATURE

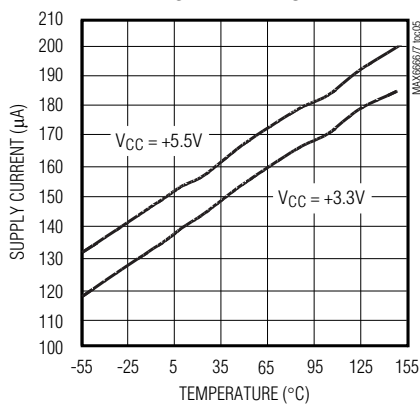

SUPPLY CURRENT vs. SUPPLY VOLTAGE

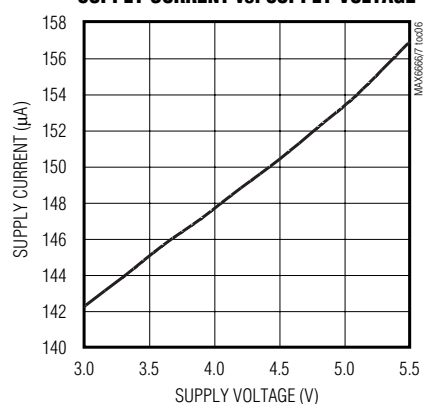

POWER-SUPPLY REJECTION RATIO vs. TEMPERATURE

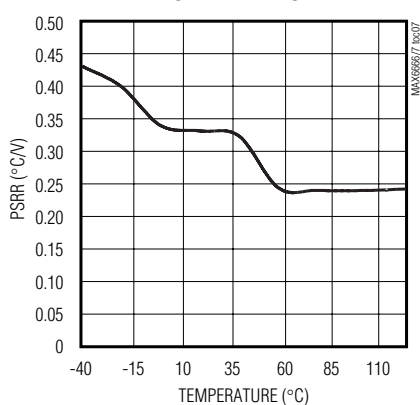

POWER-SUPPLY REJECTION vs. FREQUENCY

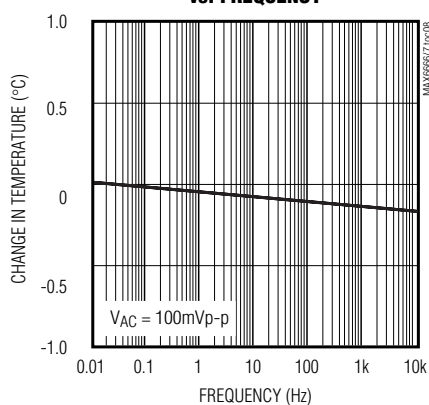

High-Accuracy PWM Output Temperature Sensors

Typical Operating Characteristics (continued)

(V_{CC} = +3.3V, T_A = +25°C, unless otherwise noted.)

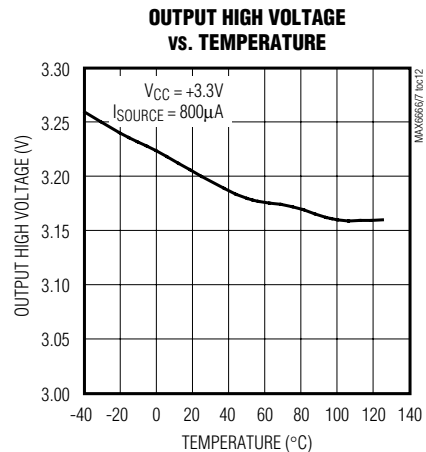
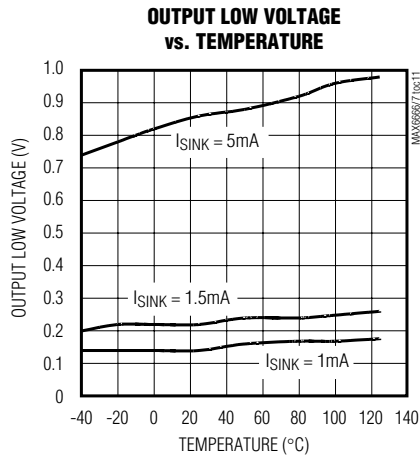
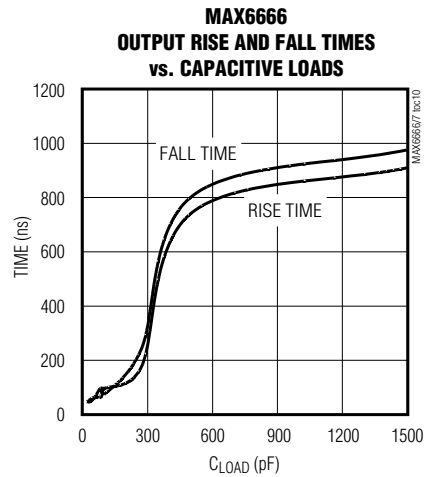
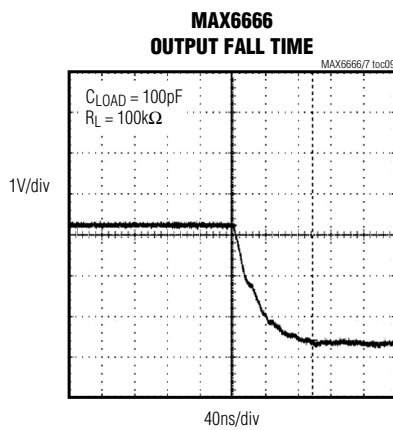

Pin Description

PIN		NAME	FUNCTION
µMAX/SO	SOT23		
1	1	D _{OUT}	Digital Output Pin. The pulse width of the output waveform is modulated by the temperature.
2	2	V _{CC}	Supply Voltage
3	3	GND	Ground
4-8	4, 5, 6	IC	Internally Connected. Leave unconnected or connect to GND.

High-Accuracy PWM Output Temperature Sensors

Detailed Description

The MAX6666/MAX6667 are high-accuracy, low-cost, low current (200 μ A typ) temperature sensors ideal for interfacing with μ Cs or μ Ps. The MAX6666/MAX6667 convert the ambient temperature into a ratiometric PWM output at a nominal frequency of 35Hz (\pm 20%) at +25°C.

The time periods, t_1 (high) and t_2 (low) (Figure 1), are easily read by the μ P's timer/counter port. To calculate the temperature, use the expression below:

$$\text{Temperature (}^\circ\text{C)} = +235 - (400 \times t_1) / t_2$$

The μ C or μ P measures the output of the MAX6666/MAX6667 by counting t_1 and t_2 and computing the temperature based on their ratio. The resolution of the count is a function of the processor clock frequency and the resolution of the counter. The MAX6666/MAX6667 have a resolution of approximately 11 bits. Always use the same clock for t_1 and t_2 counters so that the temperature is strictly based on a ratio of the two times, thus eliminating errors due to different clocks' frequencies.

The MAX6666 (Figure 2a) has a push-pull output and provides Rail-to-Rail[®] output drive. The ability to source and sink current allows the MAX6666 to drive capacitive loads up to 10nF with less than 1°C error.

The MAX6667 (Figure 2b) has an open-drain output. The output capacitance should be minimized in MAX6667 applications because the sourcing current is set by the pullup resistor. If the output capacitance becomes too large, lengthy rise and fall times distort the pulse width, resulting in inaccurate measurements.

Applications Information

Accurate temperature monitoring requires a good thermal contact between the MAX6666/MAX6667 and the object being monitored. A precise temperature measurement depends on the thermal resistance between the object being monitored and the MAX6666 die. Heat flows in and out of plastic packages primarily through the leads. For the best thermal contact, connect all unused pins to ground. If the sensor is intended to measure the temperature of a heat-generating component on the circuit board, mount the device as close as possible to that component and share the ground traces (if they are not too noisy) with the component. This maximizes the heat transfer from the component to the sensor.

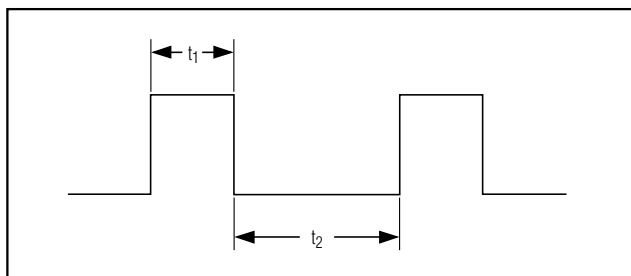

Figure 1. MAX6666/MAX6667 PWM Output

Power-Supply Bypassing

The MAX6666/MAX6667 operate from a +3V to +5.5V supply. If a noisy power-supply line is used, bypass VCC to GND with a 0.1 μ F capacitor.

Power Supply from μ P Port Pin

The low quiescent current of the MAX6666/MAX6667 enables it to be powered from a logic line, which meets the requirements for supply voltage range. This provides a simple shutdown function to totally eliminate quiescent current by taking the logic line low. The logic line must be able to withstand the 0.1 μ F power-supply bypass capacitance.

Galvanic Isolation

Use an optocoupler to isolate the MAX6666/MAX6667 whenever a high common-mode voltage is present. Because some optocouplers have turn-off times that are much longer than their turn-on times, choose an optocoupler with equal turn-on and turn-off times. Unequal turn-on/turn-off times produce an error in the temperature reading.

Thermal Considerations

Self-heating may cause the temperature measurement accuracy of the MAX6666/MAX6667 to degrade in some applications. The quiescent dissipation and the power dissipated by the digital output may cause errors in obtaining the accurate temperature measurement. The temperature errors depend on the thermal conductivity of the package (SOT23, 140°C/W; 8-pin SO, 170°C/W; 8-pin μ MAX, 242°C/W), the mounting technique, and the airflow. Static dissipation in the MAX6666/MAX6667 is typically 4.5mW operating at 5V with no load. As a worst-case example, consider the MAX6667 and its maximum rated load of 5mA and assume a maximum output voltage of 0.8V adds 4mW power dissipation. In an 8-pin μ MAX, this would result in a temperature rise of 0.004×242 or approximately

Rail-to-Rail is a registered trademark of Nippon Motorola, Ltd.

High-Accuracy PWM Output Temperature Sensors

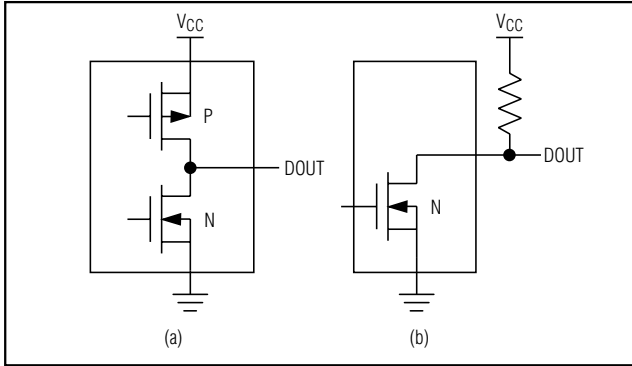

Figure 2. MAX6666/MAX6667 Output Configuration

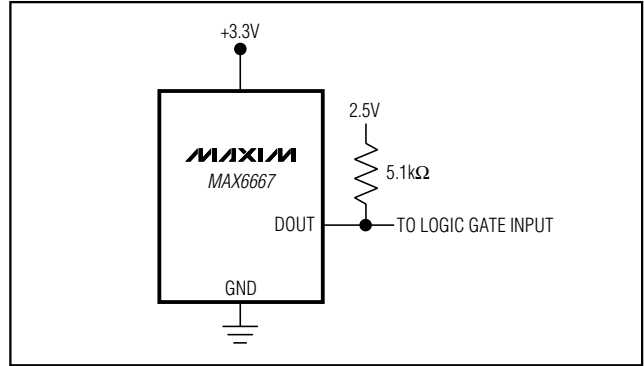

Figure 4. Low-Voltage Logic

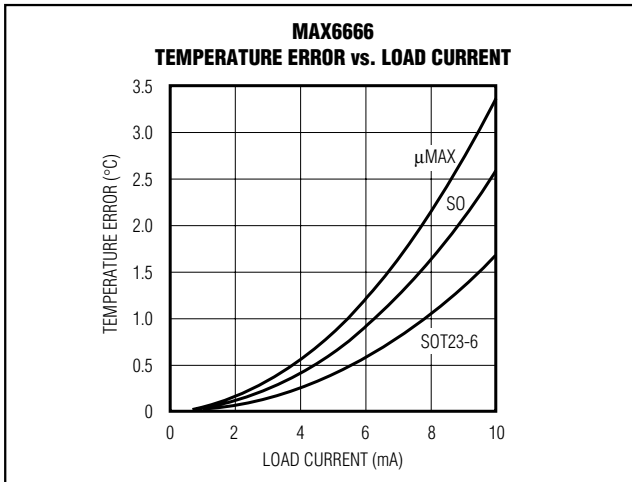

Figure 3. MAX6666 Temperature Error Due to Load Current

1°C. Use Figure 3 to estimate the temperature error with respect to the MAX6666 packages.

Low-Voltage Logic

Use the MAX6667 open-drain output to drive low-voltage devices. As shown in Figure 4, connect a pullup resistor from the low-voltage logic supply to the MAX6667 output. Limit the resistor's current to about 1mA, thus maintaining an output low logic level of less than 200mV.

Pin Configurations (continued)

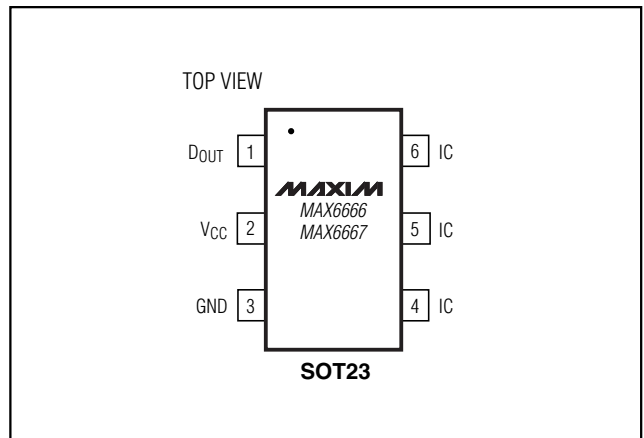

Chip Information

TRANSISTOR COUNT: 6479

PROCESS: BiCMOS

High-Accuracy PWM Output Temperature Sensors

Package Information

(The package drawing(s) in this data sheet may not reflect the most current specifications. For the latest package outline information, go to www.maxim-ic.com/packages.)

MAX6666/MAX6667

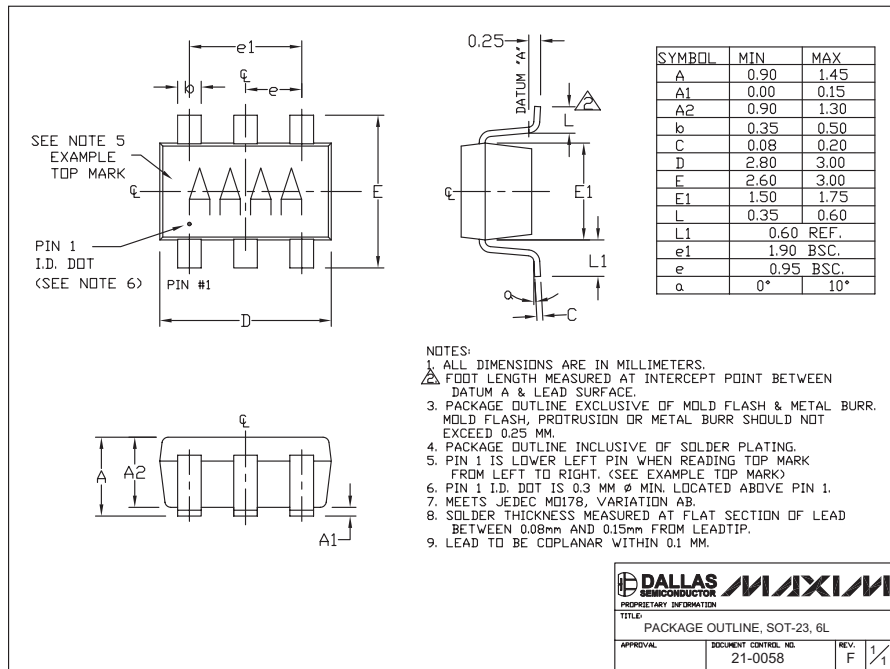

6L SOT-23 EFS

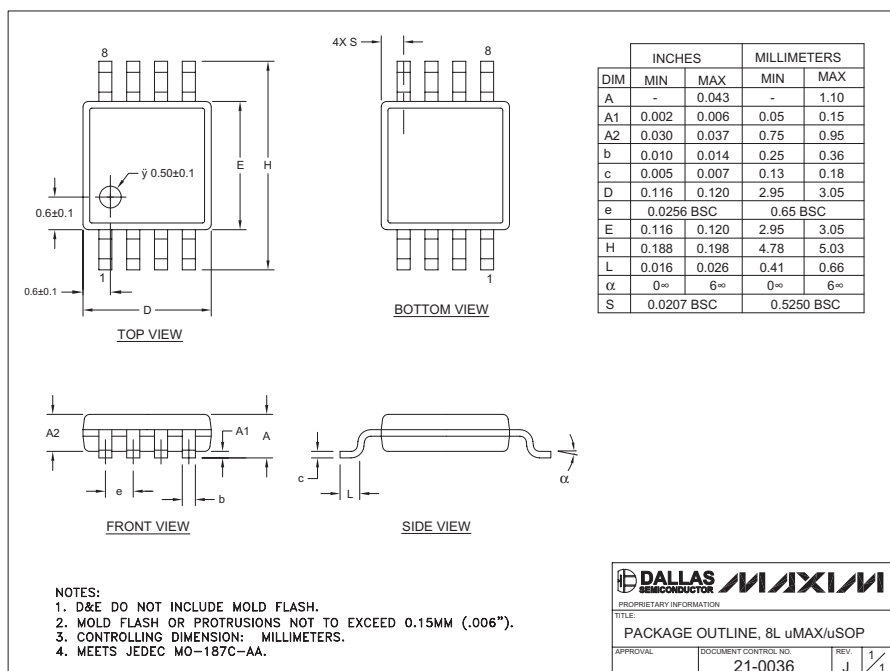

8L uMAX/uSOP

High-Accuracy PWM Output Temperature Sensors

Package Information (continued)

(The package drawing(s) in this data sheet may not reflect the most current specifications. For the latest package outline information, go to www.maxim-ic.com/packages.)

SOICN LEFS

TOP VIEW

FRONT VIEW

SIDE VIEW

NOTES:
 1. D&E DO NOT INCLUDE MOLD FLASH.
 2. MOLD FLASH OR PROTRUSIONS NOT TO EXCEED 0.15mm (.006").
 3. LEADS TO BE COPLANAR WITHIN 0.10mm (.004").
 4. CONTROLLING DIMENSION: MILLIMETERS.
 5. MEETS JEDEC MS012.
 6. N = NUMBER OF PINS.

DIM	INCHES		MILLIMETERS	
	MIN	MAX	MIN	MAX
A	0.053	0.069	1.35	1.75
A1	0.004	0.010	0.10	0.25
B	0.014	0.019	0.35	0.49
C	0.007	0.010	0.19	0.25
e	0.050 BSC		1.27 BSC	
E	0.150	0.157	3.80	4.00
H	0.228	0.244	5.80	6.20
L	0.016	0.050	0.40	1.27

VARIATIONS:

DIM	INCHES		MILLIMETERS		N	MS012
	MIN	MAX	MIN	MAX		
D	0.189	0.197	4.80	5.00	8	AA
D	0.337	0.344	8.55	8.75	14	AB
D	0.386	0.394	9.80	10.00	16	AC

DALLAS SEMICONDUCTOR **MAXIM**

PROPRIETARY INFORMATION

TITLE: PACKAGE OUTLINE, .150" SOIC

APPROVAL: _____ DOCUMENT CONTROL NO: 21-0041 REV: B 1/1

Maxim cannot assume responsibility for use of any circuitry other than circuitry entirely embodied in a Maxim product. No circuit patent licenses are implied. Maxim reserves the right to change the circuitry and specifications without notice at any time.

8 **Maxim Integrated Products, 120 San Gabriel Drive, Sunnyvale, CA 94086 408-737-7600**