



HCC/HCF4555B HCC/HCF4556B

DUAL BINARY TO 1 OF 4 DECODER/DEMULTIPLEXERS

4555B OUTPUTS HIGH ON SELECT
4556B OUTPUTS LOW ON SELECT

- EXPANDABLE WITH MULTIPLE PACKAGES
- STANDARD, SYMMETRICAL OUTPUT CHARACTERISTICS
- QUIESCENT CURRENT SPECIFIED TO 20V FOR HCC DEVICE
- 5V, 10V, AND 15V PARAMETRIC RATINGS
- INPUT CURRENT OF 100nA AT 18V AND 25°C FOR HCC DEVICE
- 100% TESTED FOR QUIESCENT CURRENT
- MEETS ALL REQUIREMENTS OF JEDEC TENTATIVE STANDARD N^o. 13A, "STANDARD SPECIFICATIONS FOR DESCRIPTION OF "B" SERIES CMOS DEVICES"

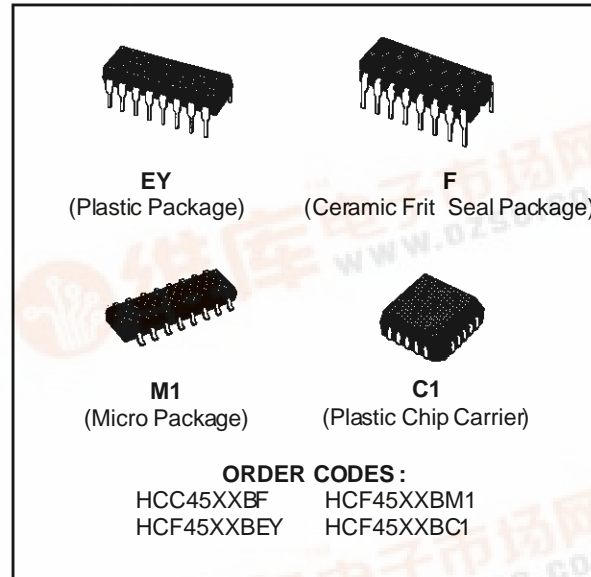

DESCRIPTION

The **HCC4555B**, **HCC4556B** (extended temperature range) and the **HCF4555B**, **HCF4556B** (intermediate temperature range) are monolithic integrated circuits available in 16-lead dual in-line plastic or ceramic package and plastic micropackage.

The **HCC/HCF4555B** and **HCC/HCF4556B** are dual one-of-four decoders/demultiplexers. Each decoder has two select inputs (A and B), an Enable input (E), and four mutually exclusive outputs. On the **HCC/HCF4555B** the outputs are high on select; on the **HCC/HCF4556B** the outputs are low on select. When the Enable input is high, the outputs of the **HCC/HCF4555B** remain low and the outputs of the **HCC/HCF4556B** remain high regardless of the state of the select inputs A and B.

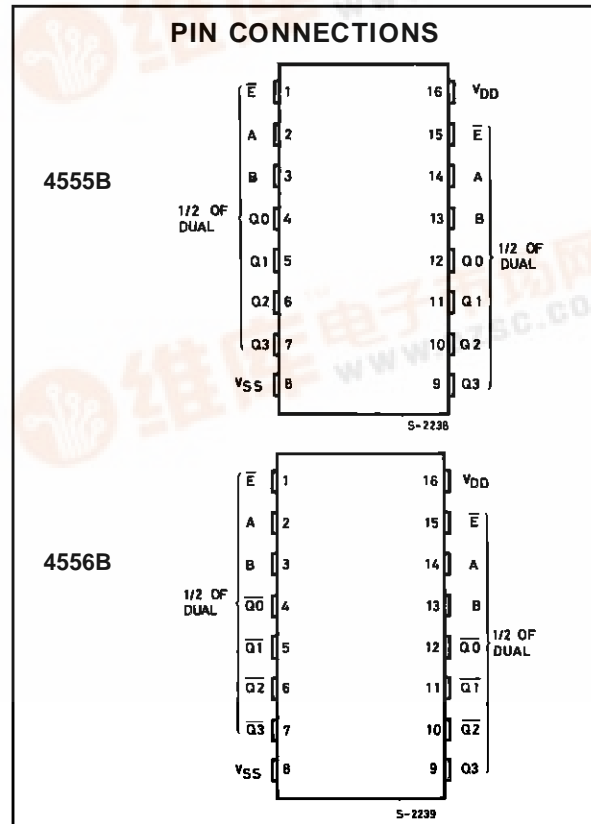

HCC/HCF4555B/4556B

FUNCTIONAL DIAGRAMS

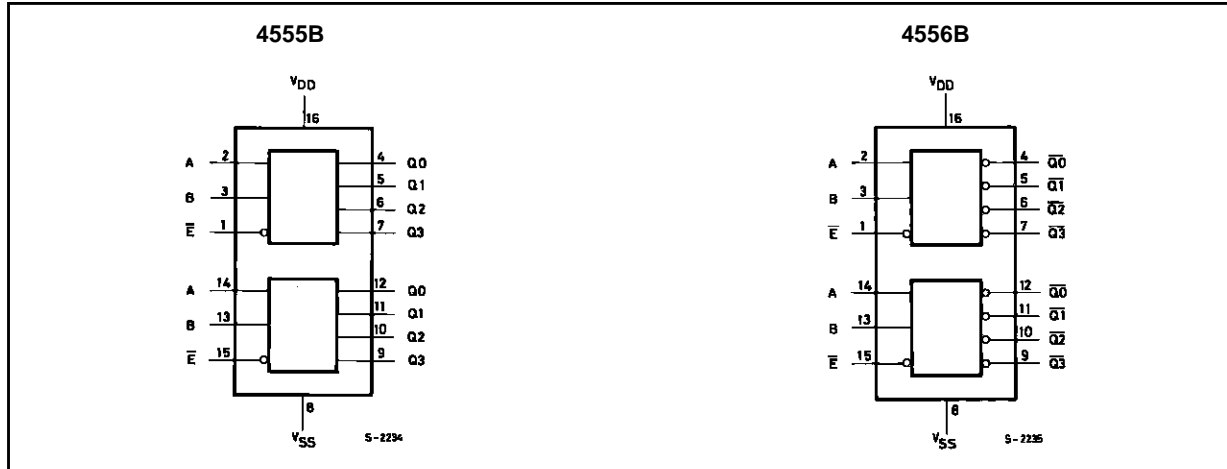

ABSOLUTE MAXIMUM RATINGS

| Symbol | Parameter | Value | Unit |
|------------|---|--------------------------------|-------------|
| V_{DD}^* | Supply Voltage : HCC Types HCF Types | - 0.5 to + 20 - 0.5 to + 18 | V |
| V_i | Input Voltage | - 0.5 to $V_{DD} + 0.5$ | V |
| I_i | DC Input Current (any one input) | ± 10 | mA |
| P_{tot} | Total Power Dissipation (per package) Dissipation per Output Transistor for $T_{op} =$ Full Package-temperature Range | 200 100 | mW |
| T_{op} | Operating Temperature : HCC Types HCF Types | - 55 to + 125 - 40 to + 85 | $^{\circ}C$ |
| T_{stg} | Storage Temperature | - 65 to + 150 | $^{\circ}C$ |

Stresses above those listed under "Absolute Maximum Ratings" may cause permanent damage to the device. This is a stress rating only and functional operation of the device at these or any other conditions above those indicated in the operational sections of this specification is not implied. Exposure to absolute maximum rating conditions for external periods may affect device reliability.

* All voltages values are referred to V_{SS} pin voltage.

RECOMMENDED OPERATING CONDITIONS

| Symbol | Parameter | Value | Unit |
|----------|--|-------------------------------|-------------|
| V_{DD} | Supply Voltage : HCC Types HCF Types | 3 to 18 3 to 15 | V |
| V_i | Input Voltage | 0 to V_{DD} | V |
| T_{op} | Operating Temperature : HCC Types HCF Types | - 55 to + 125 - 40 to + 85 | $^{\circ}C$ |

LOGIC DIAGRAMS

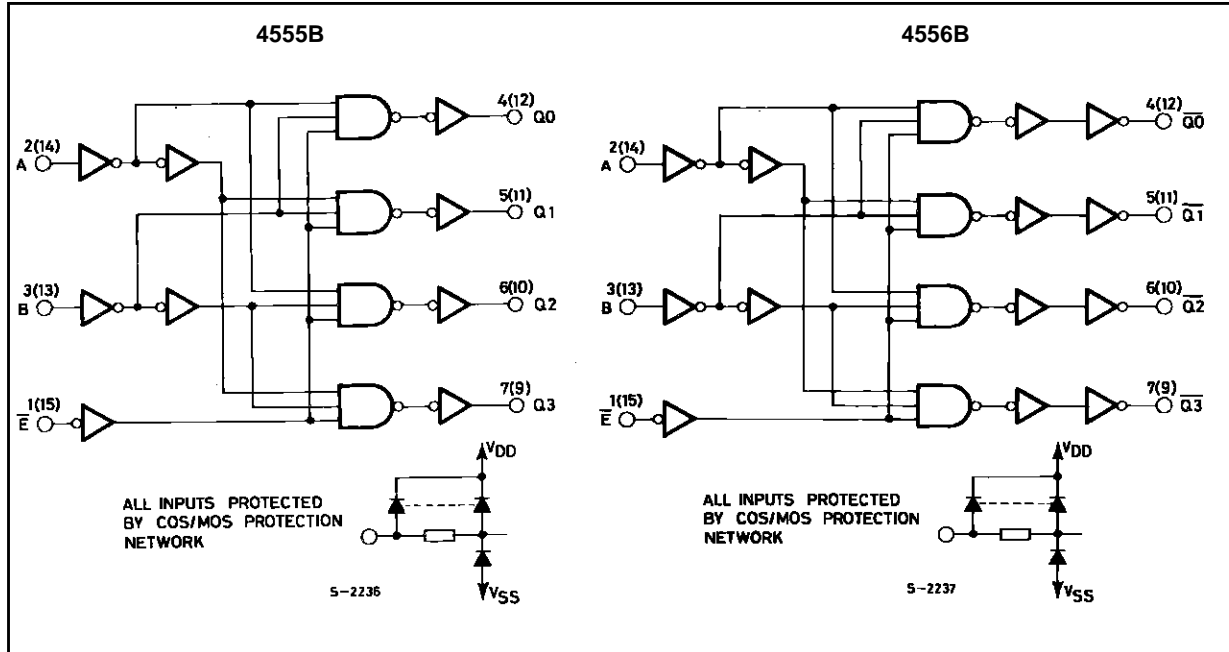

TRUTH TABLE

| Inputs Enable Select | | | Outputs 4555B | | | | Outputs 4556B | | | |
|----------------------|---|---|---------------|----|----|----|---------------|------------|------------|------------|
| \bar{E} | B | A | Q3 | Q2 | Q1 | Q0 | $\bar{Q3}$ | $\bar{Q2}$ | $\bar{Q1}$ | $\bar{Q0}$ |
| 0 | 0 | 0 | 0 | 0 | 0 | 1 | 1 | 1 | 1 | 0 |
| 0 | 0 | 1 | 0 | 0 | 1 | 0 | 1 | 1 | 0 | 1 |
| 0 | 1 | 0 | 0 | 1 | 0 | 0 | 1 | 0 | 1 | 1 |
| 0 | 1 | 1 | 1 | 0 | 0 | 0 | 0 | 1 | 1 | 1 |
| 1 | X | X | 0 | 0 | 0 | 0 | 1 | 1 | 1 | 1 |

X = DON'T CARE, LOGIC 1 = HIGH, LOGIC 0 = LOW.

HCC/HCF4555B/4556B

STATIC ELECTRICAL CHARACTERISTICS (over recommended operating conditions)

| Symbol | Parameter | | Test Conditions | | | | Value | | | | | | Unit | |
|-----------------------------------|-----------------------|-----------|-----------------------|-----------------------|--------------------------------|------------------------|--------------------|-----------|--------|------------------------|-----------|---------------------|---------|---------|
| | | | V _I (V) | V _O (V) | I _O (μ A) | V _{DD} (V) | T _{Low} * | | 25°C | | | T _{High} * | | |
| | | | | | | | Min. | Max. | Min. | Typ. | Max. | Min. | | Max. |
| I _L | Quiescent Current | HCC Types | 0/ 5 | | | 5 | | 5 | | 0.04 | 5 | | 150 | μ A |
| | | | 0/10 | | | 10 | | 10 | | 0.04 | 10 | | 300 | |
| | | | 0/15 | | | 15 | | 20 | | 0.04 | 20 | | 600 | |
| | | | 0/20 | | | 20 | | 100 | | 0.08 | 100 | | 3000 | |
| | | HCF Types | 0/ 5 | | | 5 | | 20 | | 0.04 | 20 | | 150 | |
| | | | 0/10 | | | 10 | | 40 | | 0.04 | 40 | | 300 | |
| V _{OH} | Output High Voltage | | 0/ 5 | | < 1 | 5 | 4.95 | | 4.95 | | | 4.95 | V | |
| | | | 0/10 | | < 1 | 10 | 9.95 | | 9.95 | | | 9.95 | | |
| | | | 0/15 | | < 1 | 15 | 14.95 | | 14.95 | | | 14.95 | | |
| V _{OL} | Output Low Voltage | | 5/0 | | < 1 | 5 | | 0.05 | | | 0.05 | | V | |
| | | | 10/0 | | < 1 | 10 | | 0.05 | | | 0.05 | | | |
| | | | 15/0 | | < 1 | 15 | | 0.05 | | | 0.05 | | | |
| V _{IH} | Input High Voltage | | | 0.5/4.5 | < 1 | 5 | 3.5 | | 3.5 | | | 3.5 | V | |
| | | | | 1/9 | < 1 | 10 | 7 | | 7 | | | 7 | | |
| | | | | 1.5/13.5 | < 1 | 15 | 11 | | 11 | | | 11 | | |
| V _{IL} | Input Low Voltage | | | 4.5/0.5 | < 1 | 5 | | 1.5 | | | 1.5 | | V | |
| | | | | 9/1 | < 1 | 10 | | 3 | | | 3 | | | |
| | | | | 13.5/1.5 | < 1 | 15 | | 4 | | | 4 | | | |
| I _{OH} | Output Drive Current | HCC Types | 0/ 5 | 2.5 | | 5 | - 2 | | - 1.6 | - 3.2 | | - 1.15 | mA | |
| | | | 0/ 5 | 4.6 | | 5 | - 0.64 | | - 0.51 | - 1 | | - 0.36 | | |
| | | | 0/10 | 9.5 | | 10 | - 1.6 | | - 1.3 | - 2.6 | | - 0.9 | | |
| | | | 0/15 | 13.5 | | 15 | - 4.2 | | - 3.4 | - 6.8 | | - 2.4 | | |
| | | HCF Types | 0/ 5 | 2.5 | | 5 | - 1.53 | | - 1.36 | - 3.2 | | - 1.1 | | |
| | | | 0/ 5 | 4.6 | | 5 | - 0.52 | | - 0.44 | - 1 | | - 0.36 | | |
| | | | 0/10 | 9.5 | | 10 | - 1.3 | | - 1.1 | - 2.6 | | - 0.9 | | |
| | | | 0/15 | 13.5 | | 15 | - 3.6 | | - 3.0 | - 6.8 | | - 2.4 | | |
| I _{OL} | Output Sink Current | HCC Types | 0/ 5 | 0.4 | | 5 | 0.64 | | 0.51 | 1 | | 0.36 | mA | |
| | | | 0/10 | 0.5 | | 10 | 1.6 | | 1.3 | 2.6 | | 0.9 | | |
| | | | 0/15 | 1.5 | | 15 | 4.2 | | 3.4 | 6.8 | | 2.4 | | |
| | | HCF Types | 0/ 5 | 0.4 | | 5 | 0.52 | | 0.44 | 1 | | 0.36 | | |
| | | | 0/10 | 0.5 | | 10 | 1.3 | | 1.1 | 2.6 | | 0.9 | | |
| | | | 0/15 | 1.5 | | 15 | 3.6 | | 3.0 | 6.8 | | 2.4 | | |
| I _{IH} , I _{IL} | Input Leakage Current | HCC Types | 0/18 | Any Input | | 18 | | \pm 0.1 | | \pm 10 ⁻⁵ | \pm 0.1 | | \pm 1 | μ A |
| | | HCF Types | 0/15 | | | 15 | | \pm 0.3 | | \pm 10 ⁻⁵ | \pm 0.3 | | \pm 1 | |
| C _I | Input Capacitance | | | Any Input | | | | | 5 | 7.5 | | | pF | |

(*) T_{LOW} = - 55°C for HCC device ; - 40°C for HCF device.

(*) T_{HIGH} = + 125°C for HCC device ; + 85°C for HCF device.

The Noise Margin for both "1" and "0" level is : 1V min. with V_{DD} = 5V, 2V min. with V_{DD} = 10V, 2.5V min. with V_{DD} = 15V.

DYNAMIC ELECTRICAL CHARACTERISTICS ($T_{amb} = 25^{\circ}\text{C}$, $C_L = 50\text{pF}$, $R_L = 200\text{k}\Omega$, typical temperature coefficient for all V_{DD} values is $0.3\%/^{\circ}\text{C}$, all input rise and fall times = 20ns)

| Symbol | Parameter | Test Conditions | | Value | | | Unit |
|--------------------------|--|-----------------|--------------|-------|------|------|------|
| | | | V_{DD} (V) | Min. | Typ. | Max. | |
| t_{PLH} , t_{PHL} | Propagation Delay Time (A or B input to any output) | | 5 | | 220 | 440 | ns |
| | | | 10 | | 95 | 190 | |
| | | | 15 | | 70 | 140 | |
| | Propagation Delay Time (\bar{E} input to any output) | | 5 | | 200 | 400 | ns |
| | | | 10 | | 85 | 170 | |
| | | | 15 | | 65 | 130 | |
| t_{TLH} , t_{THL} | Transition Time | | 5 | | 100 | 200 | ns |
| | | | 10 | | 50 | 100 | |
| | | | 15 | | 40 | 80 | |

Typical Output Low (sink) Current Characteristics.

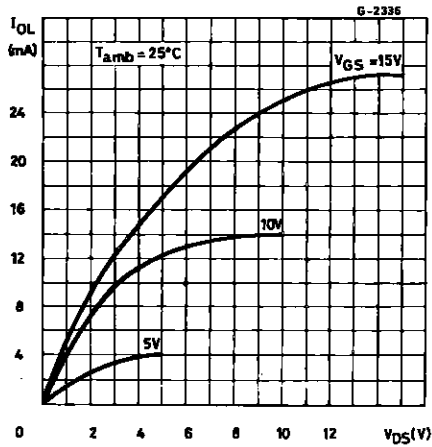

Minimum Output Low (sink) Current Characteristics.

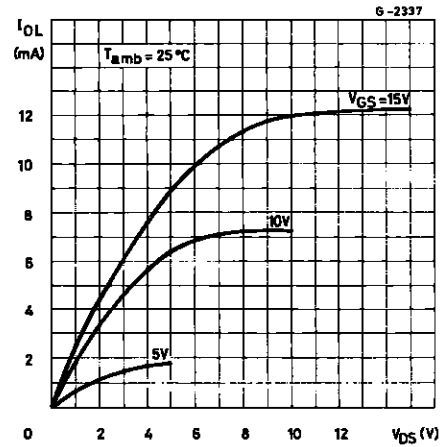

Typical Output High (source) Current Characteristics.

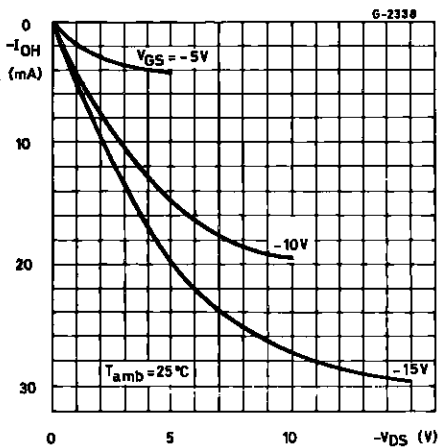

Minimum Output High (source) Current Characteristics.

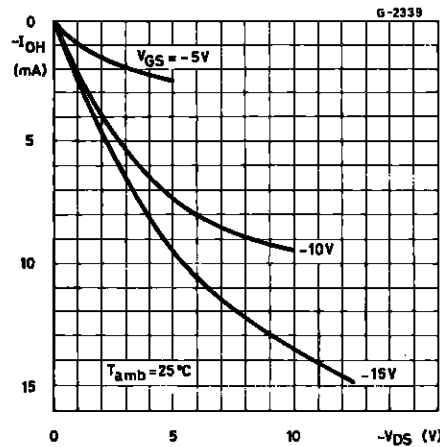

HCC/HCF4555B/4556B

Typical Propagation Delay Time vs. Load Capacitance (A or B input to any output).

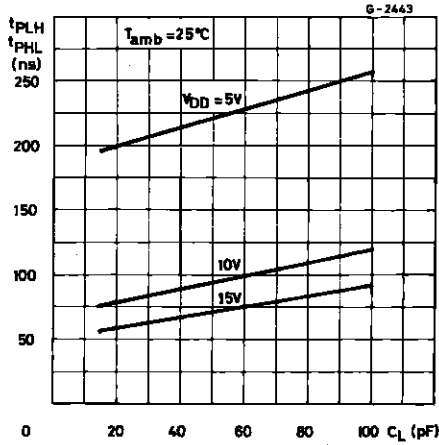

Typical Propagation Delay Time vs. Load Capacitance (E input to any input).

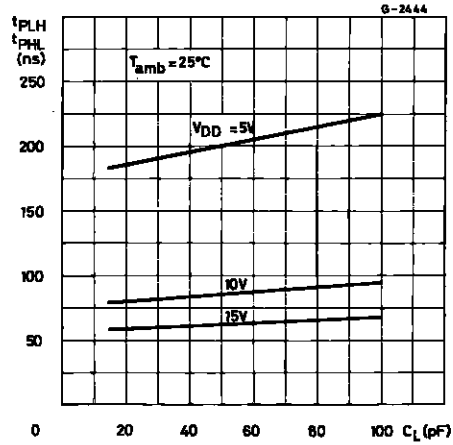

Typical Propagation Delay Time vs. Supply Voltage.

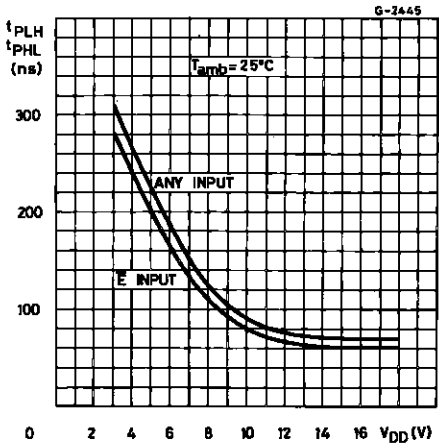

Typical Transition Time vs. Load Capacitance.

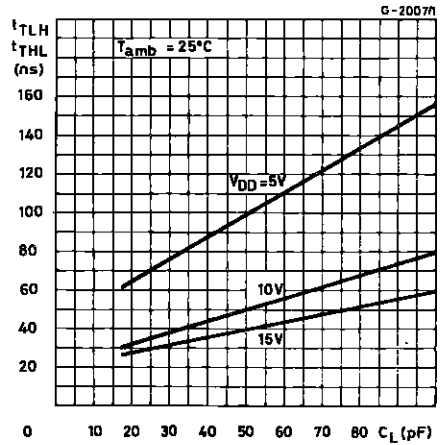

Typical Dynamic Power Dissipation/per Device vs. Frequency.

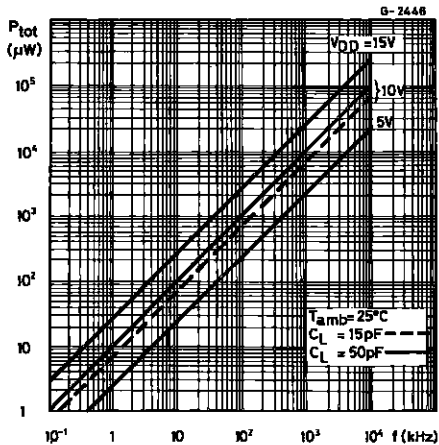

APPLICATIONS

1 of 4 Line Data Demultiplexer using HCC/HCF4555B

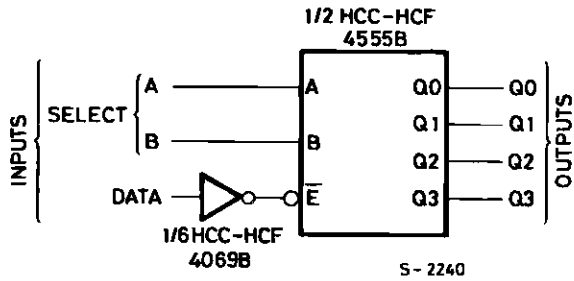

TRUTH TABLE

| Select Inputs | | Outputs | | | |
|---------------|---|---------|------|------|------|
| B | A | Q 0 | Q 1 | Q 2 | Q 3 |
| 0 | 0 | DATA | 0 | 0 | 0 |
| 0 | 1 | 0 | DATA | 0 | 0 |
| 1 | 0 | 0 | 0 | DATA | 0 |
| 1 | 1 | 0 | 0 | 0 | DATA |

1 of 8 Decoder using HCC/HCF 4555B

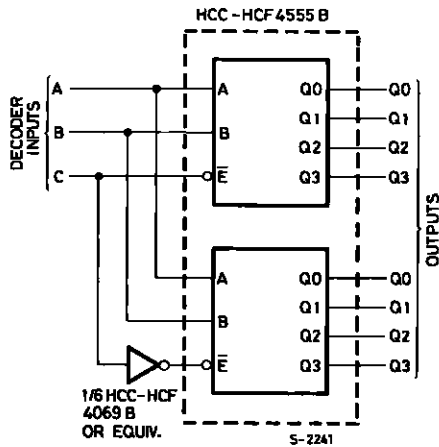

TRUTH TABLE

| Inputs | | | Q Outputs | | | | | | | |
|--------|---|---|-----------|---|---|---|---|---|---|---|
| C | B | A | 0 | 1 | 2 | 3 | 4 | 5 | 6 | 7 |
| 0 | 0 | 0 | 1 | 0 | 0 | 0 | 0 | 0 | 0 | 0 |
| 0 | 0 | 1 | 0 | 1 | 0 | 0 | 0 | 0 | 0 | 0 |
| 0 | 1 | 0 | 0 | 0 | 1 | 0 | 0 | 0 | 0 | 0 |
| 0 | 1 | 1 | 0 | 0 | 0 | 1 | 0 | 0 | 0 | 0 |
| 1 | 0 | 0 | 0 | 0 | 0 | 0 | 1 | 0 | 0 | 0 |
| 1 | 0 | 1 | 0 | 0 | 0 | 0 | 0 | 1 | 0 | 0 |
| 1 | 1 | 0 | 0 | 0 | 0 | 0 | 0 | 0 | 1 | 0 |
| 1 | 1 | 1 | 0 | 0 | 0 | 0 | 0 | 0 | 0 | 1 |

HCC/HCF4555B/4556B

APPLICATIONS (continued)

1 of 16 Decoder using HCC/HCF4555B and HCC/HCF4556B

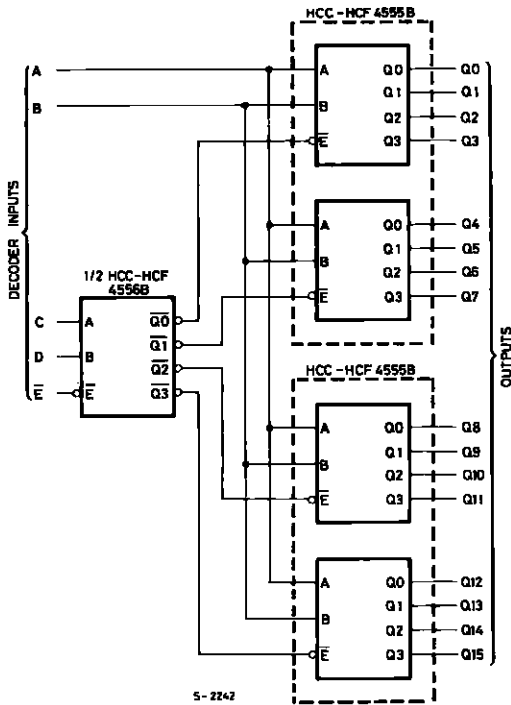

TRUTH TABLE

| Inputs | | | | | Q Outputs | | | | | | | | | | | | | | | |
|--------|---|---|---|---|-----------|---|---|---|---|---|---|---|---|---|----|----|----|----|----|----|
| E | D | C | B | A | 0 | 1 | 2 | 3 | 4 | 5 | 6 | 7 | 8 | 9 | 10 | 11 | 12 | 13 | 14 | 15 |
| 0 | 0 | 0 | 0 | 0 | 1 | 0 | 0 | 0 | 0 | 0 | 0 | 0 | 0 | 0 | 0 | 0 | 0 | 0 | 0 | 0 |
| 0 | 0 | 0 | 0 | 1 | 0 | 1 | 0 | 0 | 0 | 0 | 0 | 0 | 0 | 0 | 0 | 0 | 0 | 0 | 0 | 0 |
| 0 | 0 | 0 | 1 | 0 | 0 | 0 | 1 | 0 | 0 | 0 | 0 | 0 | 0 | 0 | 0 | 0 | 0 | 0 | 0 | 0 |
| 0 | 0 | 0 | 1 | 1 | 0 | 0 | 0 | 1 | 0 | 0 | 0 | 0 | 0 | 0 | 0 | 0 | 0 | 0 | 0 | 0 |
| 0 | 0 | 1 | 0 | 0 | 0 | 0 | 0 | 0 | 1 | 0 | 0 | 0 | 0 | 0 | 0 | 0 | 0 | 0 | 0 | 0 |
| 0 | 0 | 1 | 0 | 1 | 0 | 0 | 0 | 0 | 0 | 1 | 0 | 0 | 0 | 0 | 0 | 0 | 0 | 0 | 0 | 0 |
| 0 | 0 | 1 | 1 | 0 | 0 | 0 | 0 | 0 | 0 | 0 | 1 | 0 | 0 | 0 | 0 | 0 | 0 | 0 | 0 | 0 |
| 0 | 0 | 1 | 1 | 1 | 0 | 0 | 0 | 0 | 0 | 0 | 0 | 1 | 0 | 0 | 0 | 0 | 0 | 0 | 0 | 0 |
| 0 | 1 | 0 | 0 | 0 | 0 | 0 | 0 | 0 | 0 | 0 | 0 | 0 | 1 | 0 | 0 | 0 | 0 | 0 | 0 | 0 |
| 0 | 1 | 0 | 0 | 1 | 0 | 0 | 0 | 0 | 0 | 0 | 0 | 0 | 0 | 1 | 0 | 0 | 0 | 0 | 0 | 0 |
| 0 | 1 | 0 | 1 | 0 | 0 | 0 | 0 | 0 | 0 | 0 | 0 | 0 | 0 | 0 | 1 | 0 | 0 | 0 | 0 | 0 |
| 0 | 1 | 0 | 1 | 1 | 0 | 0 | 0 | 0 | 0 | 0 | 0 | 0 | 0 | 0 | 0 | 1 | 0 | 0 | 0 | 0 |
| 0 | 1 | 1 | 0 | 0 | 0 | 0 | 0 | 0 | 0 | 0 | 0 | 0 | 0 | 0 | 0 | 0 | 1 | 0 | 0 | 0 |
| 0 | 1 | 1 | 0 | 1 | 0 | 0 | 0 | 0 | 0 | 0 | 0 | 0 | 0 | 0 | 0 | 0 | 0 | 1 | 0 | 0 |
| 0 | 1 | 1 | 1 | 0 | 0 | 0 | 0 | 0 | 0 | 0 | 0 | 0 | 0 | 0 | 0 | 0 | 0 | 0 | 1 | 0 |
| 0 | 1 | 1 | 1 | 1 | 0 | 0 | 0 | 0 | 0 | 0 | 0 | 0 | 0 | 0 | 0 | 0 | 0 | 0 | 0 | 1 |
| 1 | X | X | X | X | 0 | 0 | 0 | 0 | 0 | 0 | 0 | 0 | 0 | 0 | 0 | 0 | 0 | 0 | 0 | 0 |

X = Don't care.

HCC/HCF4555B Input to Q3 Output Dynamic Signal Waveforms

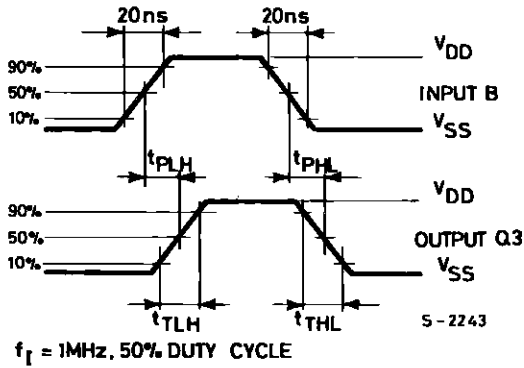

HCC/HCF4556B Input to $\overline{Q3}$ Output Dynamic Signal Waveforms

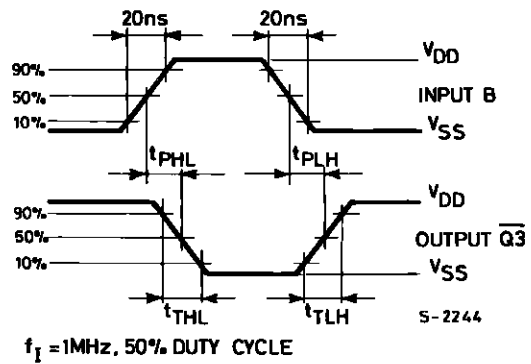

APPLICATIONS (continued)

HCC/HCF4555B \bar{E} Input to Q3 Output Dynamic Signal Waveforms

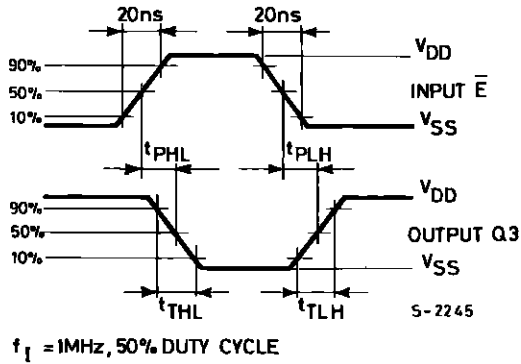

HCC/HCF4556B \bar{E} Input to $\bar{Q}3$ Output Dynamic Signal Waveforms

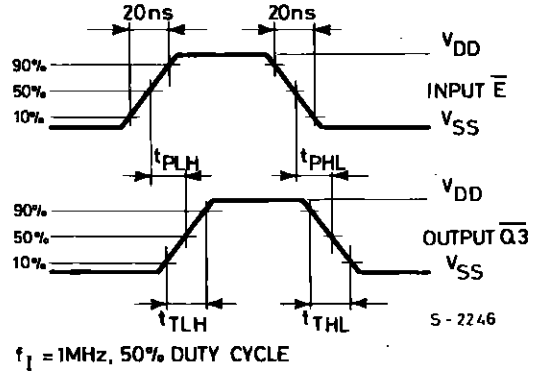

TEST CIRCUITS

Quiescent Device Current.

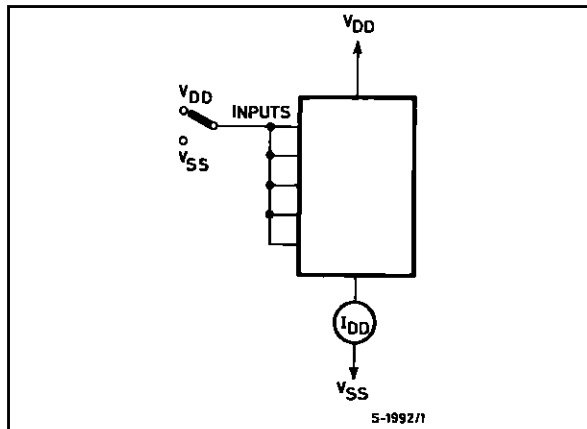

Noise Immunity.

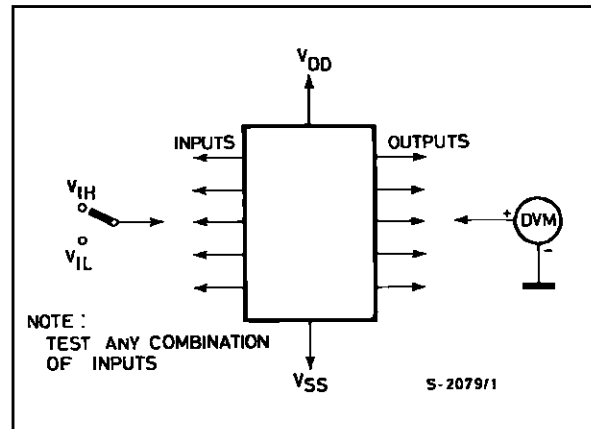

Input Leakage Current.

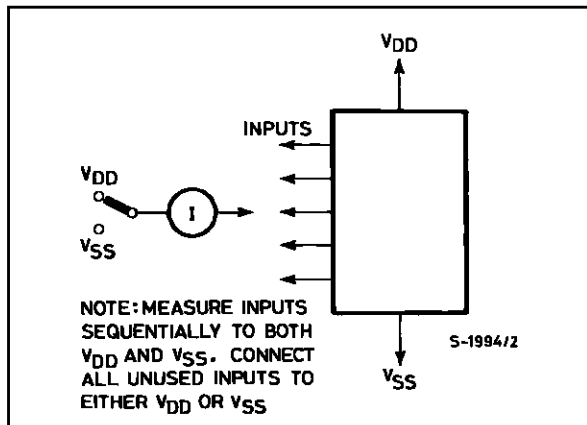

HCC/HCF4555B/4556B

Plastic DIP16 (0.25) MECHANICAL DATA

| DIM. | mm | | | inch | | |
|------|------|-------|------|-------|-------|-------|
| | MIN. | TYP. | MAX. | MIN. | TYP. | MAX. |
| a1 | 0.51 | | | 0.020 | | |
| B | 0.77 | | 1.65 | 0.030 | | 0.065 |
| b | | 0.5 | | | 0.020 | |
| b1 | | 0.25 | | | 0.010 | |
| D | | | 20 | | | 0.787 |
| E | | 8.5 | | | 0.335 | |
| e | | 2.54 | | | 0.100 | |
| e3 | | 17.78 | | | 0.700 | |
| F | | | 7.1 | | | 0.280 |
| I | | | 5.1 | | | 0.201 |
| L | | 3.3 | | | 0.130 | |
| Z | | | 1.27 | | | 0.050 |

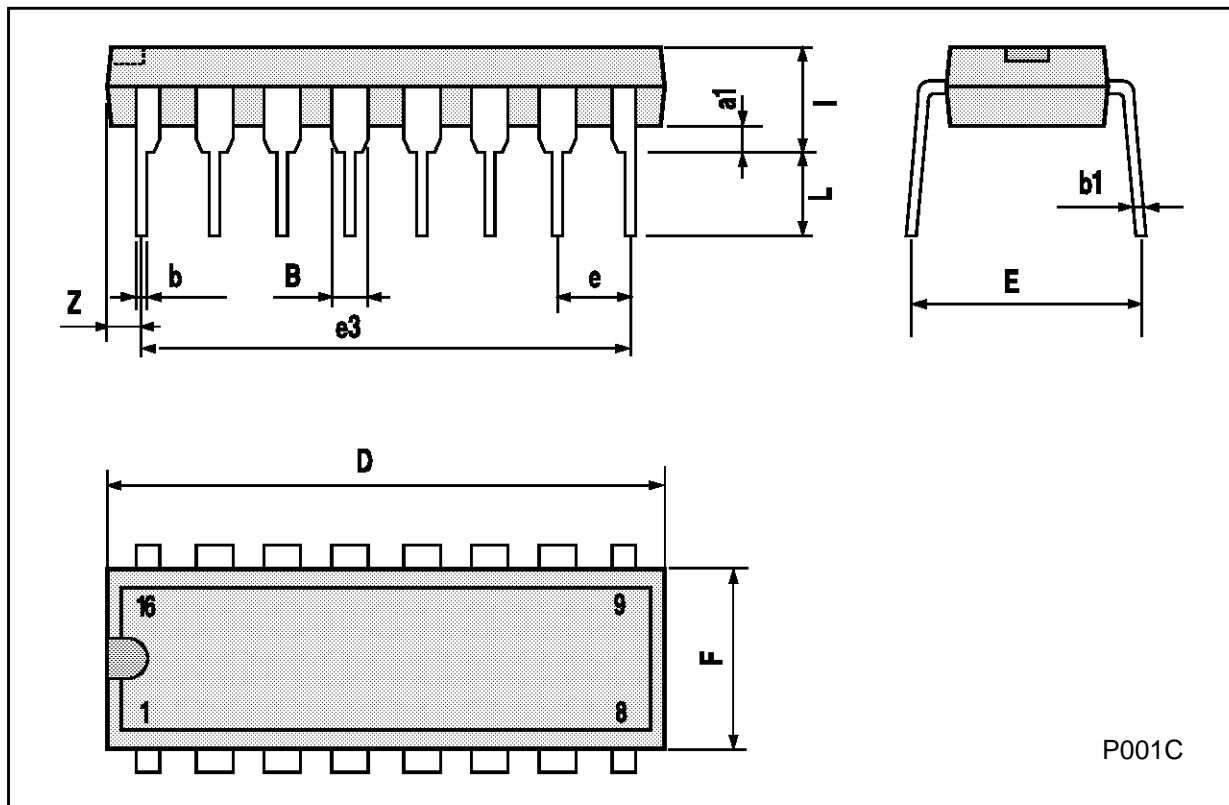

P001C

Ceramic DIP16/1 MECHANICAL DATA

| DIM. | mm | | | inch | | |
|------|------|-------|------|-------|-------|-------|
| | MIN. | TYP. | MAX. | MIN. | TYP. | MAX. |
| A | | | 20 | | | 0.787 |
| B | | | 7 | | | 0.276 |
| D | | 3.3 | | | 0.130 | |
| E | 0.38 | | | 0.015 | | |
| e3 | | 17.78 | | | 0.700 | |
| F | 2.29 | | 2.79 | 0.090 | | 0.110 |
| G | 0.4 | | 0.55 | 0.016 | | 0.022 |
| H | 1.17 | | 1.52 | 0.046 | | 0.060 |
| L | 0.22 | | 0.31 | 0.009 | | 0.012 |
| M | 0.51 | | 1.27 | 0.020 | | 0.050 |
| N | | | 10.3 | | | 0.406 |
| P | 7.8 | | 8.05 | 0.307 | | 0.317 |
| Q | | | 5.08 | | | 0.200 |

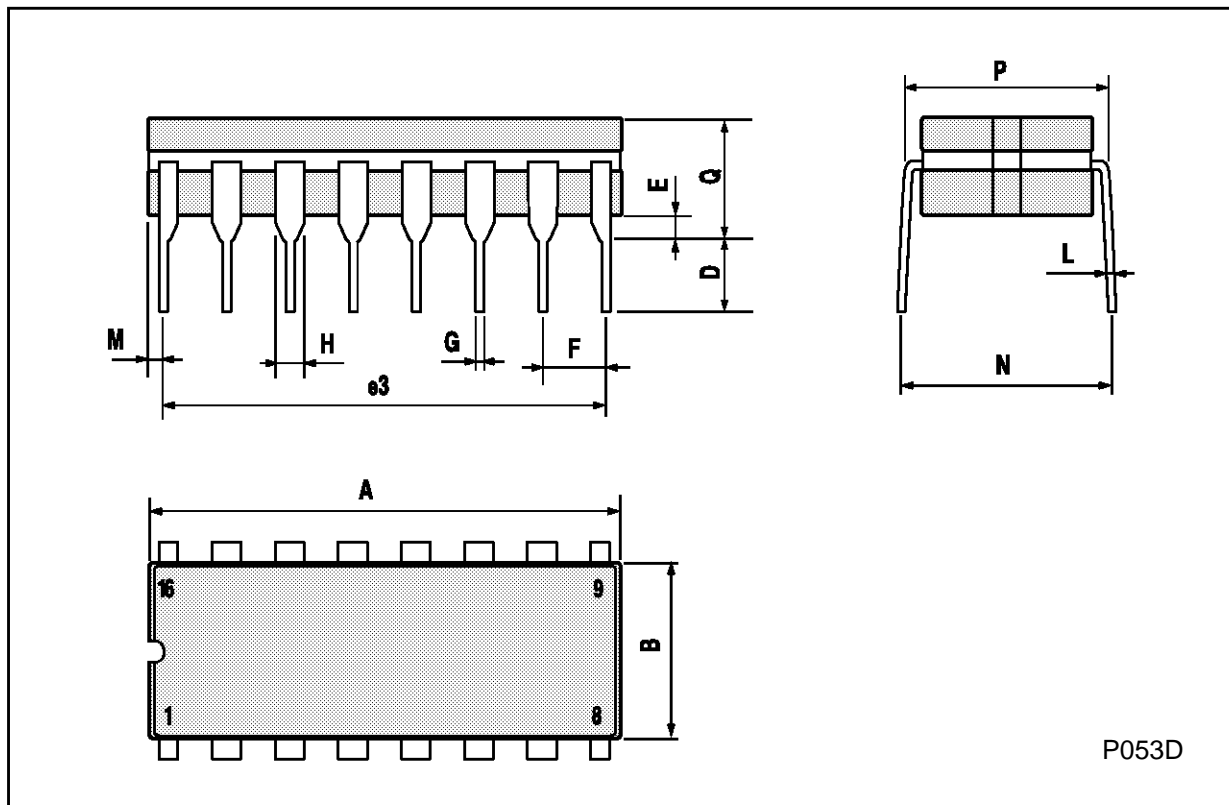

P053D

SO16 (Narrow) MECHANICAL DATA

| DIM. | mm | | | inch | | |
|------|------------|------|------|-------|-------|-------|
| | MIN. | TYP. | MAX. | MIN. | TYP. | MAX. |
| A | | | 1.75 | | | 0.068 |
| a1 | 0.1 | | 0.2 | 0.004 | | 0.007 |
| a2 | | | 1.65 | | | 0.064 |
| b | 0.35 | | 0.46 | 0.013 | | 0.018 |
| b1 | 0.19 | | 0.25 | 0.007 | | 0.010 |
| C | | 0.5 | | | 0.019 | |
| c1 | 45° (typ.) | | | | | |
| D | 9.8 | | 10 | 0.385 | | 0.393 |
| E | 5.8 | | 6.2 | 0.228 | | 0.244 |
| e | | 1.27 | | | 0.050 | |
| e3 | | 8.89 | | | 0.350 | |
| F | 3.8 | | 4.0 | 0.149 | | 0.157 |
| G | 4.6 | | 5.3 | 0.181 | | 0.208 |
| L | 0.5 | | 1.27 | 0.019 | | 0.050 |
| M | | | 0.62 | | | 0.024 |
| S | 8° (max.) | | | | | |

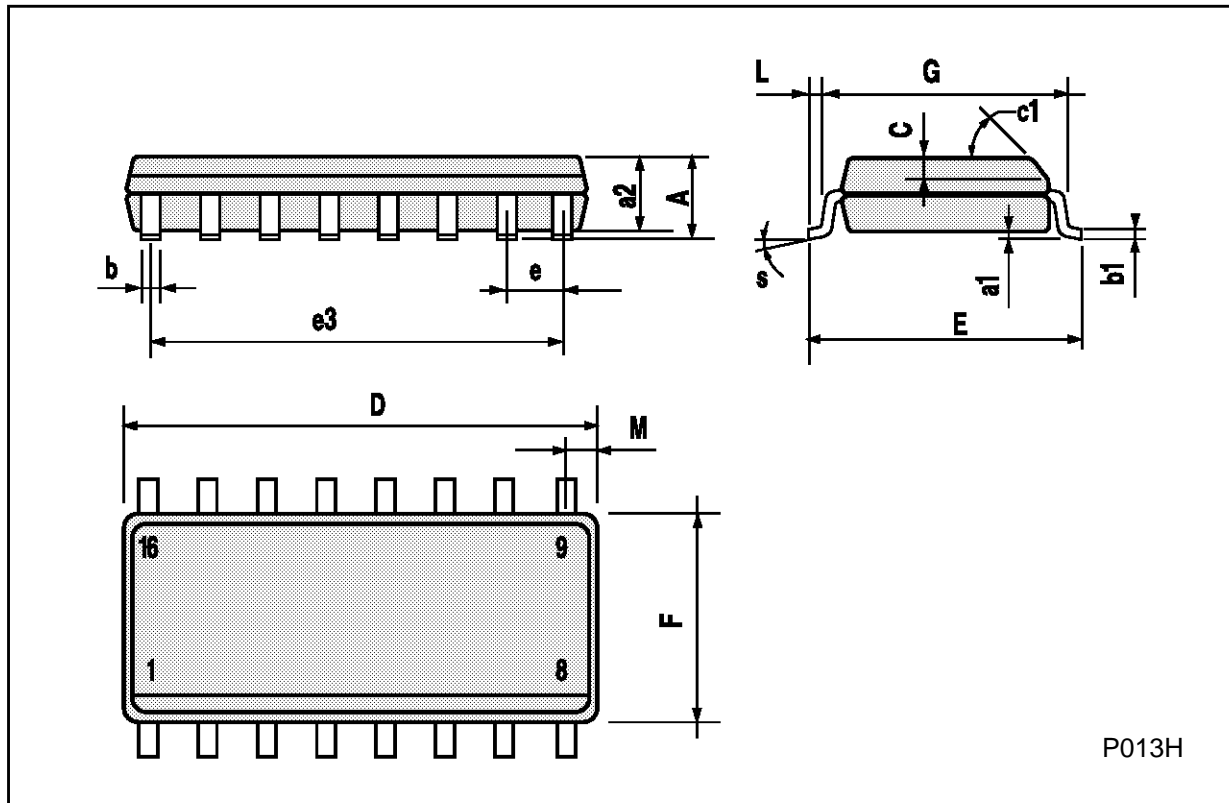

P013H

PLCC20 MECHANICAL DATA

| DIM. | mm | | | inch | | |
|------|------|------|-------|-------|-------|-------|
| | MIN. | TYP. | MAX. | MIN. | TYP. | MAX. |
| A | 9.78 | | 10.03 | 0.385 | | 0.395 |
| B | 8.89 | | 9.04 | 0.350 | | 0.356 |
| D | 4.2 | | 4.57 | 0.165 | | 0.180 |
| d1 | | 2.54 | | | 0.100 | |
| d2 | | 0.56 | | | 0.022 | |
| E | 7.37 | | 8.38 | 0.290 | | 0.330 |
| e | | 1.27 | | | 0.050 | |
| e3 | | 5.08 | | | 0.200 | |
| F | | 0.38 | | | 0.015 | |
| G | | | 0.101 | | | 0.004 |
| M | | 1.27 | | | 0.050 | |
| M1 | | 1.14 | | | 0.045 | |

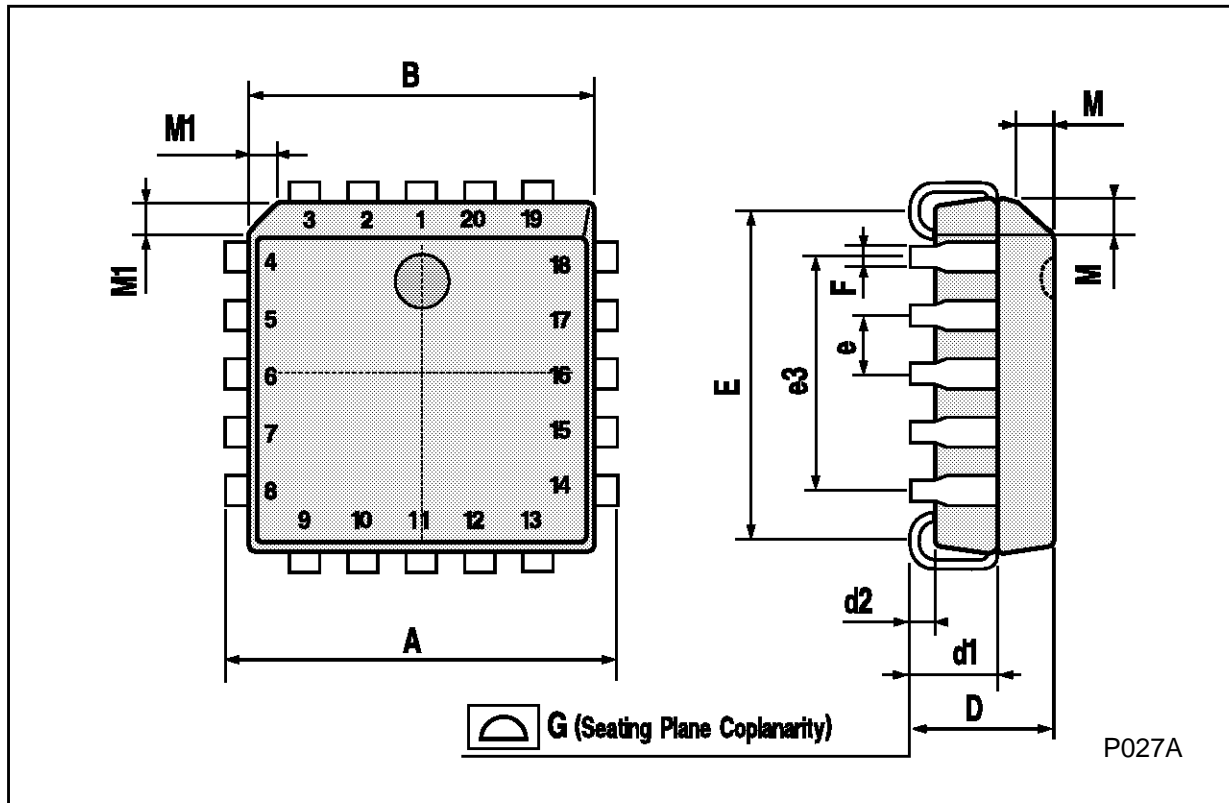

HCC/HCF4555B/4556B

Information furnished is believed to be accurate and reliable. However, SGS-THOMSON Microelectronics assumes no responsibility for the consequences of use of such information nor for any infringement of patents or other rights of third parties which may result from its use. No license is granted by implication or otherwise under any patent or patent rights of SGS-THOMSON Microelectronics. Specifications mentioned in this publication are subject to change without notice. This publication supersedes and replaces all information previously supplied. SGS-THOMSON Microelectronics products are not authorized for use as critical components in life support devices or systems without express written approval of SGS-THOMSON Microelectronics.

© 1994 SGS-THOMSON Microelectronics - All Rights Reserved

SGS-THOMSON Microelectronics GROUP OF COMPANIES
Australia - Brazil - France - Germany - Hong Kong - Italy - Japan - Korea - Malaysia - Malta - Morocco - The Netherlands -
Singapore - Spain - Sweden - Switzerland - Taiwan - Thailand - United Kingdom - U.S.A