

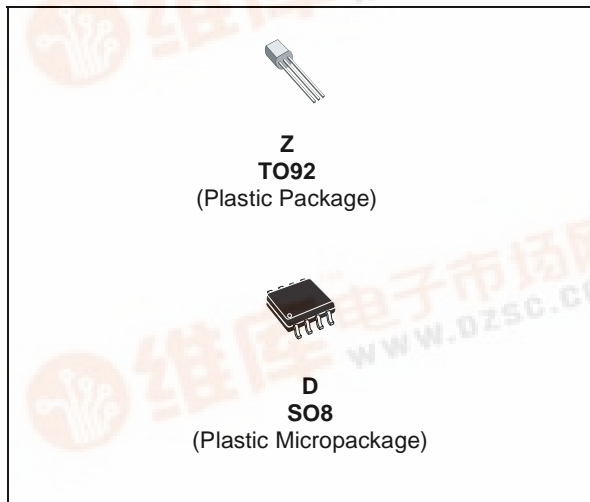

LM236 LM336,B

2.5V VOLTAGE REFERENCES

- LOW TEMPERATURE COEFFICIENT
- WIDE OPERATING CURRENT OF 400µA TO 10mA
- 0.2Ω DYNAMIC IMPEDANCE
- GUARANTEED TEMPERATURE STABILITY
- FAST TURN-ON



DESCRIPTION

The LM236 and LM336 are precision 2.5V regulator diodes. These voltage reference monolithic ICs operate like 2.5V zener diodes with a low temperature coefficient and a dynamic impedance of 0.2Ω. A third pin enables adjusting the reference voltage and the temperature coefficient.

PIN CONNECTIONS (top view)

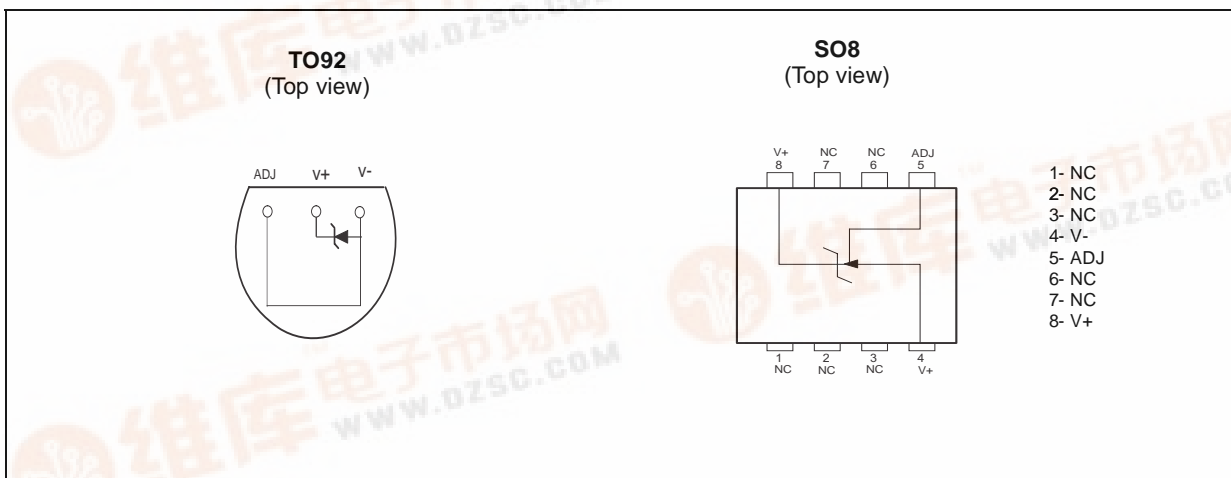

ORDER CODE

Part Number	Temperature Range	Package	
		Z	D
LM236	-25°C, +85°C	•	•
LM336,B	0°C, +70°C	•	•

Z = TO92 Plastic package - also available in Bulk (Z), Tape & Reel (ZT) and Ammo Pack (AP)
D = Small Outline Package (SO) - also available in Tape & Reel (DT)

LM236 - LM336,B

SCHEMATIC DIAGRAM

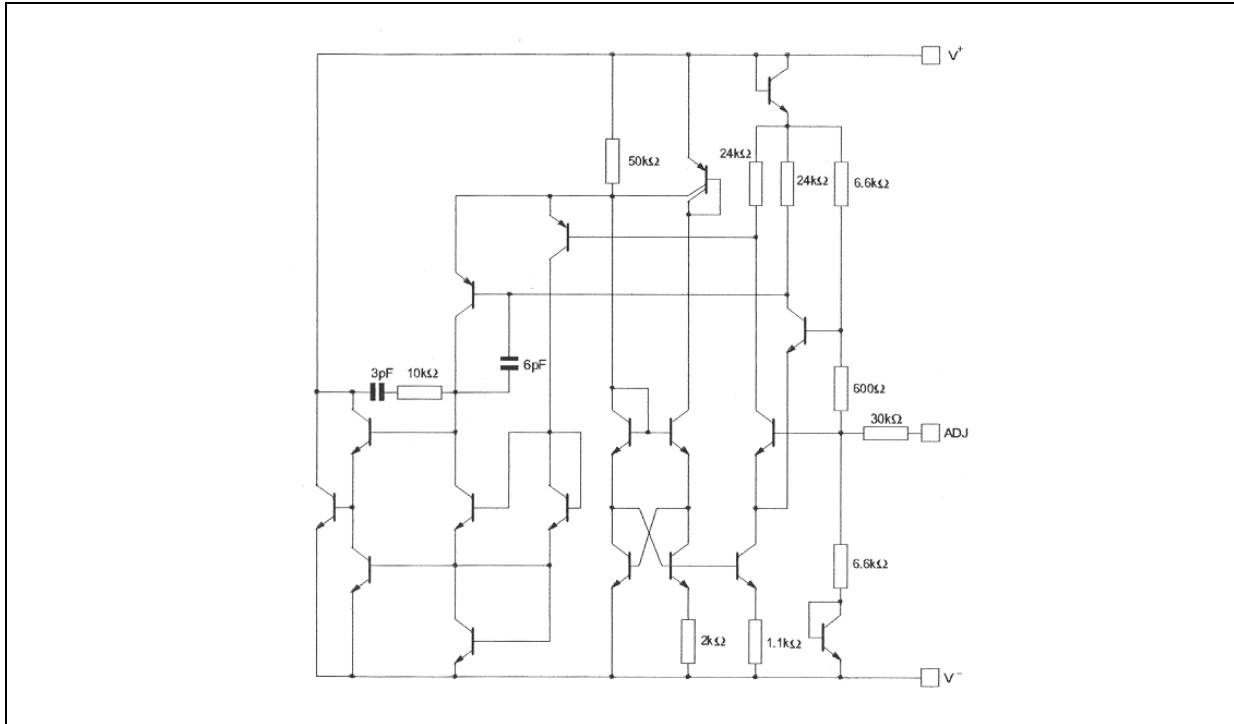

ABSOLUTE MAXIMUM RATINGS

Symbol	Parameter	LM236	LM336,B	Unit
I_R I_F	Current Reverse Forward	15 10		mA
T_{oper}	Operating Free-air Temperature Range	-25 to +85	0 to +70	°C
T_{Stg}	Storage Temperature Range	-65 to +150		°C

ELECTRICAL CHARACTERISTICS

Symbol	Parameter	LM236			LM336,B			Unit
		Min.	Typ.	Max.	Min.	Typ.	Max.	
V_R	Reference Breakdown Voltage $T_{amb} = +25^\circ\text{C}$, $I_R = 1\text{mA}$ LM236, LM336 LM336B	2.44	2.49	2.54	2.39 2.44	2.49 2.49	2.59 2.54	V
ΔV_R	Reverse Breakdown Voltage Change with Current $400\mu\text{A} \leq I_R \leq 10\text{mA}$ $T_{amb} = +25^\circ\text{C}$ $T_{min.} \leq T_{amb} \leq T_{max.}$		2.6 3	6 10		2.6 3	10 12	mV
Z_D	Reverse Dynamic Impedance ($I_R = 1\text{mA}$) $T_{amb} = +25^\circ\text{C}$ $T_{min.} \leq T_{amb} \leq T_{max.}$		0.2 0.4	0.6 1		0.2 0.4	1 1.4	Ω
K_{VT}	Temperature Stability ($V_R = 2.49\text{V}$, $I_R = 1\text{mA}$)		3.5	9		1.8	6	mV
K_{VH}	Long Term Stability ($T_{amb} = +25^\circ\text{C} \pm 0.1^\circ\text{C}$, $I_R = 1\text{mA}$)		20			20		ppm

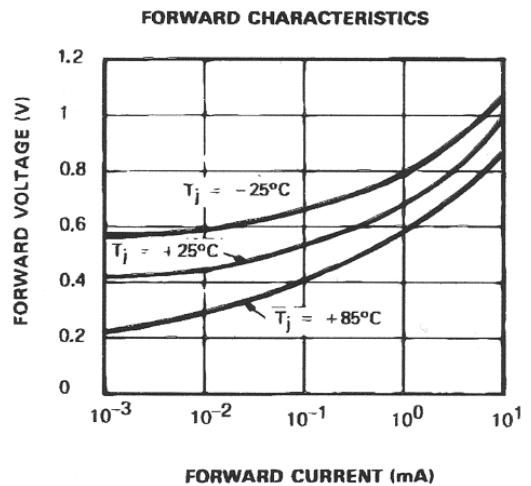
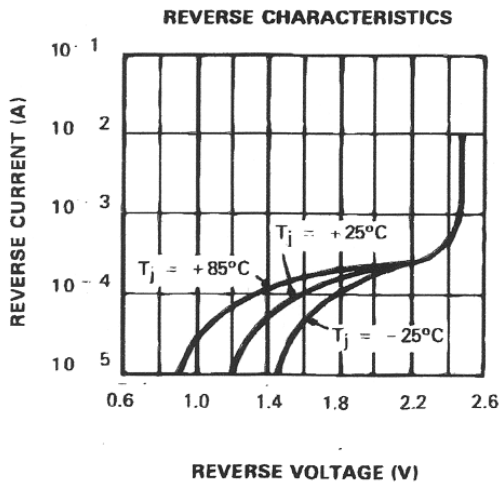
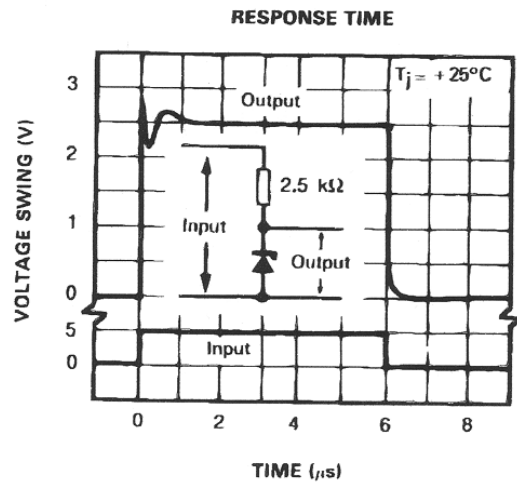
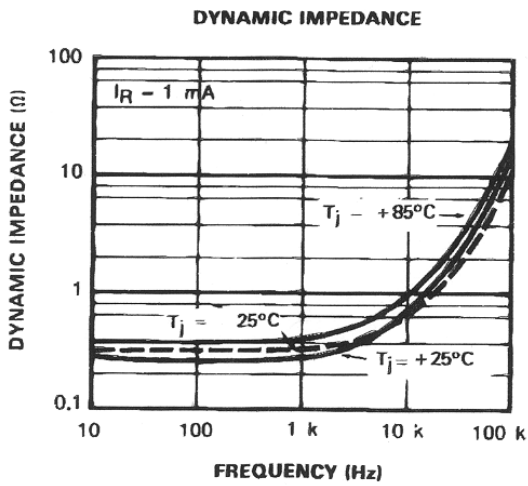
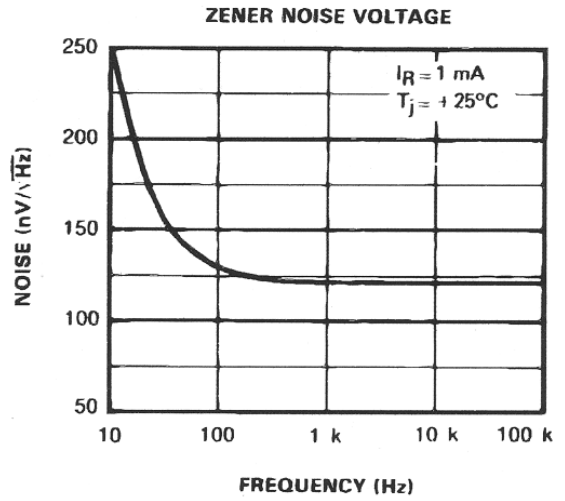
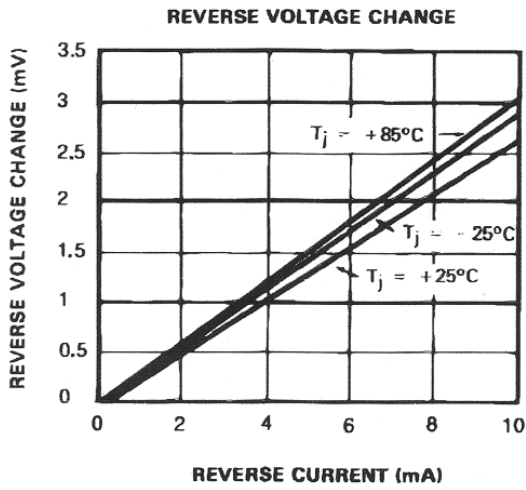

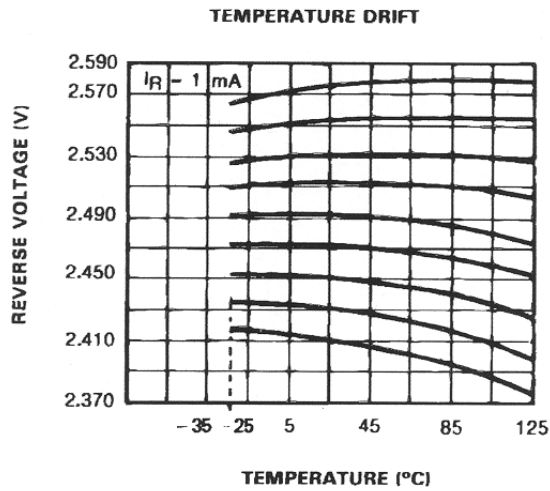
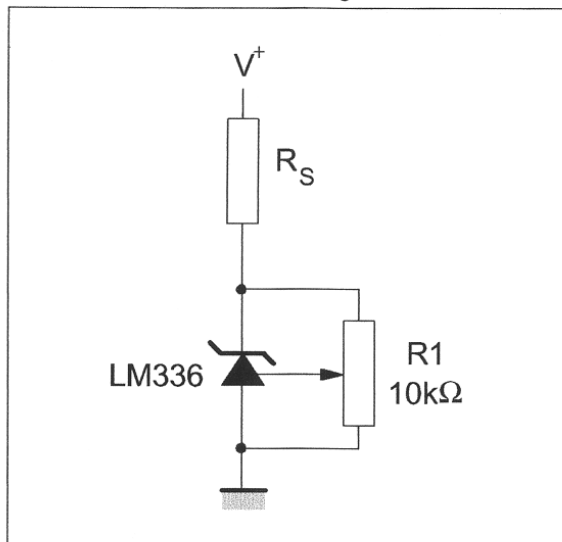

Figure 1 : The LM336 with Pot for Adjustment of Breakdown Voltage



APPLICATION HINTS

The LM236, LM336 voltage references are easier to use than zener diodes. Their low impedance and wide current range facilitate biasing in any circuits. Besides, the breakdown voltage or the temperature coefficient can be adjusted so as to optimize the performance of the circuit.

Figure 1 represents a LM336 with a 10kΩ potentiometer to adjust the reverse breakdown voltage which can be adjusted without altering the temperature coefficient of the circuit. The adjustment range is generally sufficient to adjust the initial tolerance of the circuit and the inaccuracy of the amplifier circuit.

To obtain a lower temperature coefficient two diodes can be connected in series as indicated in Figure 2.

When the circuit is adjusted to 2.49V the temperature coefficient is minimized.

For a correct temperature coefficient, the diodes should be at the same ambient temperature as the LM336. The value of R1 is not critical (2-20kΩ).

Figure 2 : Temperature Coefficient Adjustment

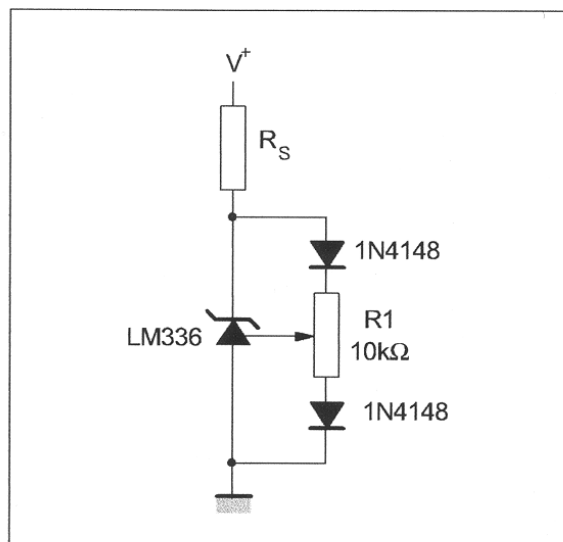

TYPICAL APPLICATIONS

Figure 3 : 2.5V Reference

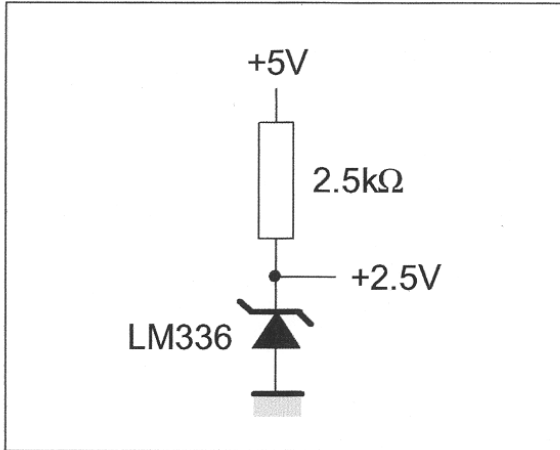

Figure 4 : Wide Input Range Reference

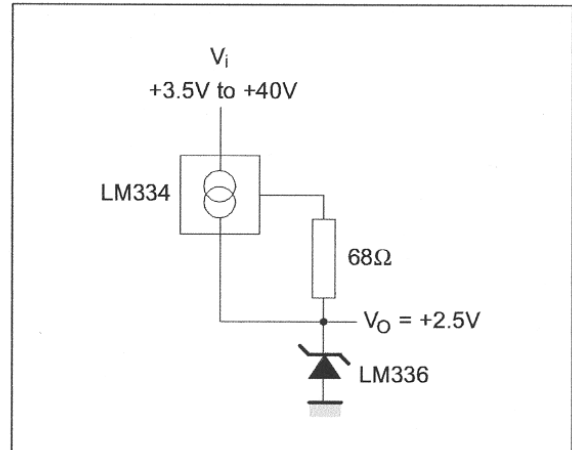

Figure 5 : Precision Power Regulator with Low Temperature Coefficient

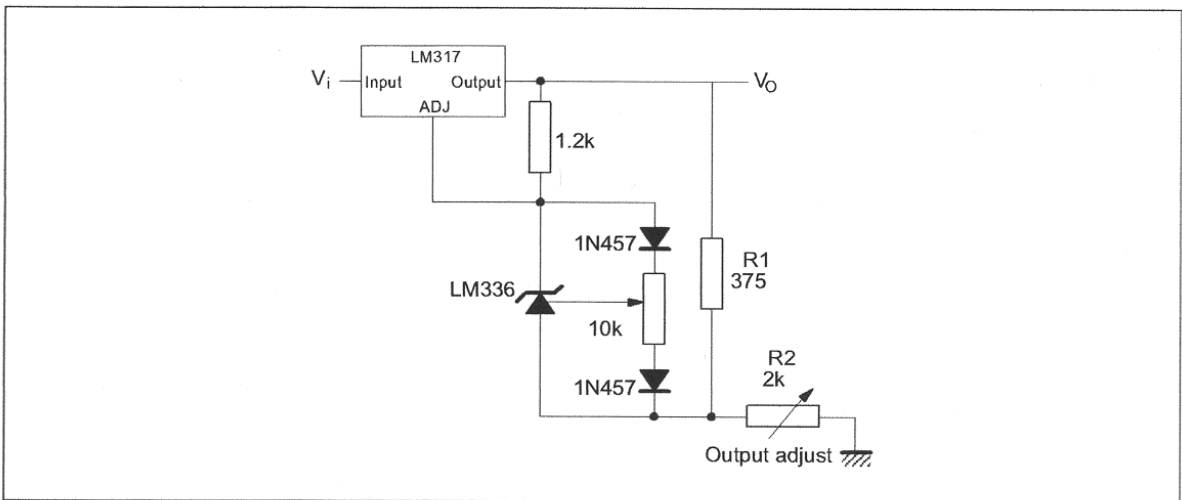

Figure 6 : Adjustable Shunt Regulator

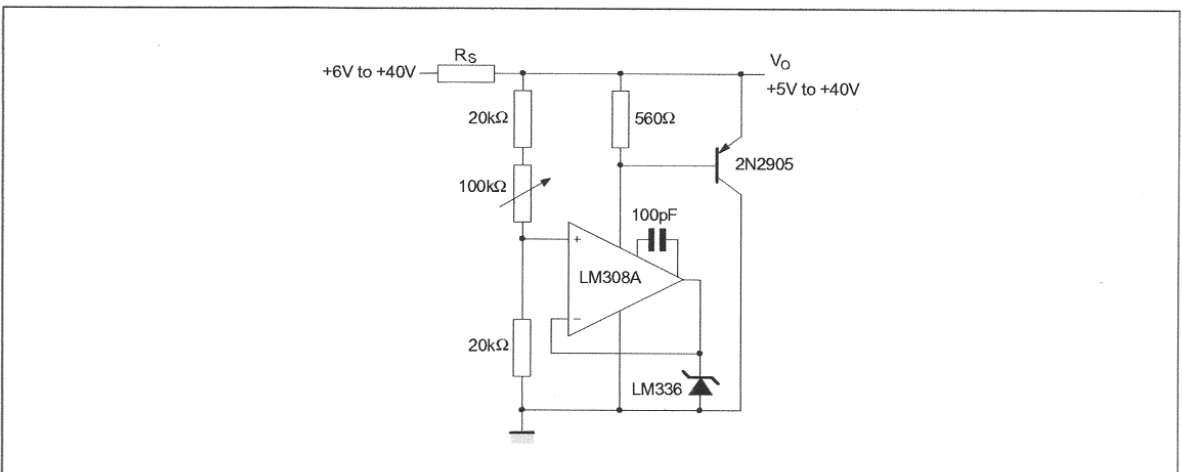

Figure 7 : Linear Ohmmeter

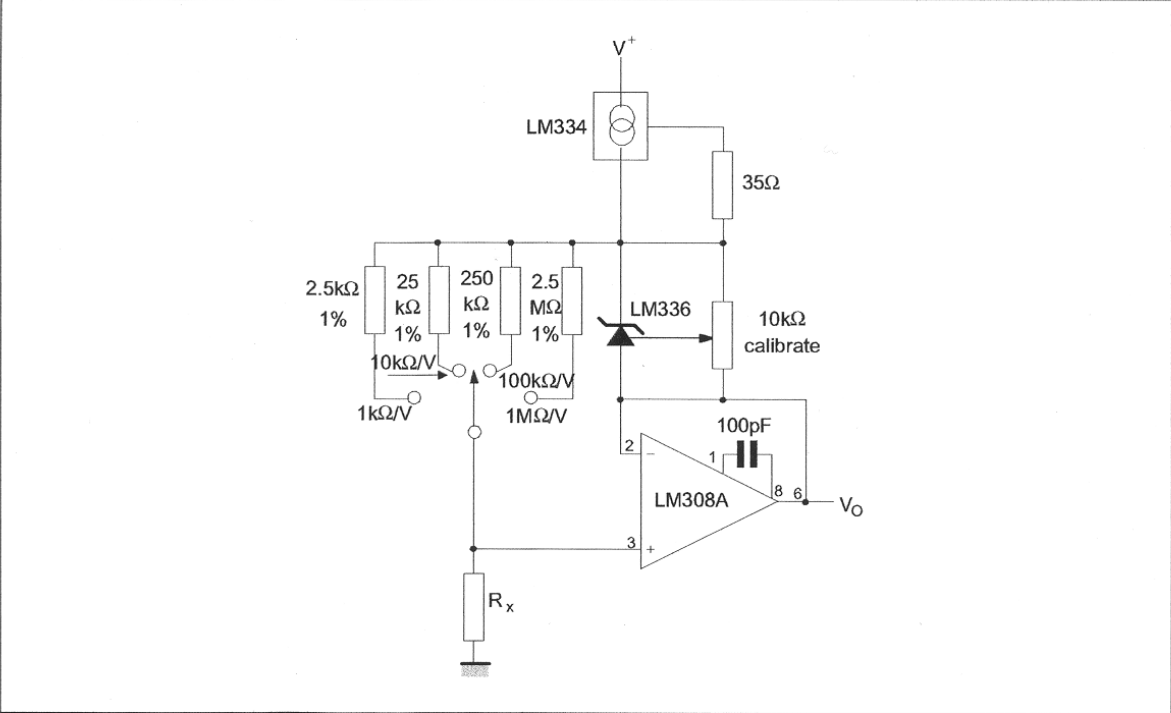

Figure 8 : Bipolar Output Reference

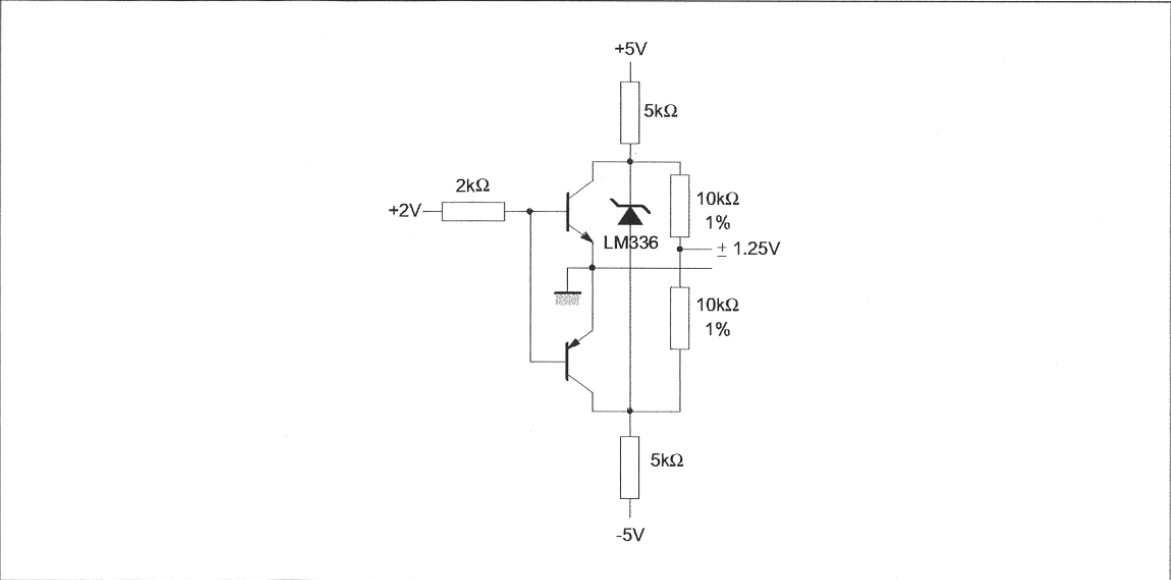

Figure 9 : 5V Buffered Reference

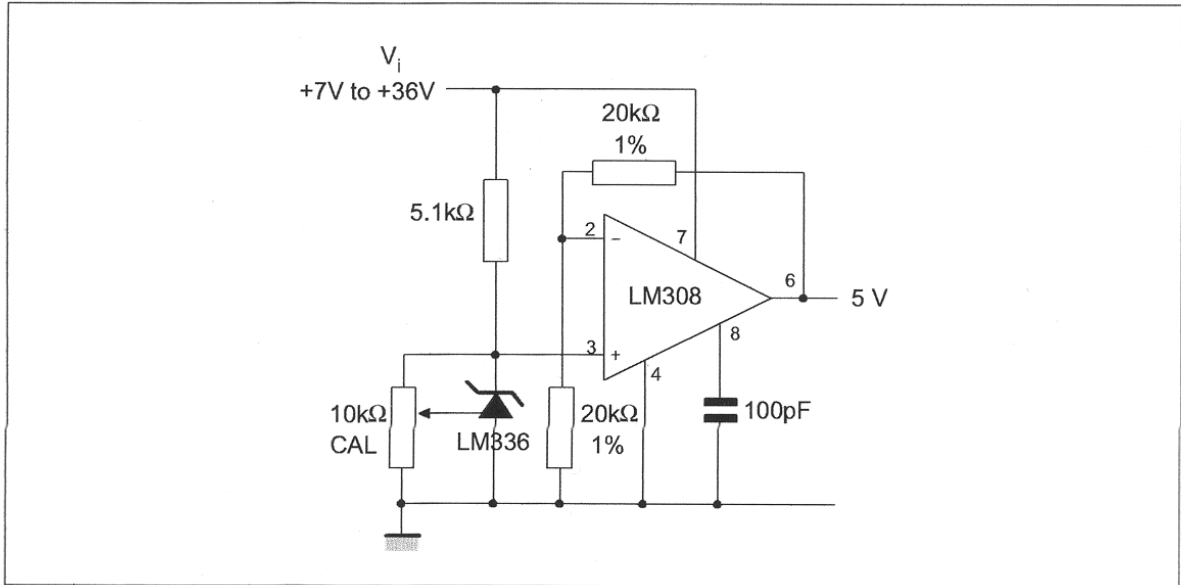
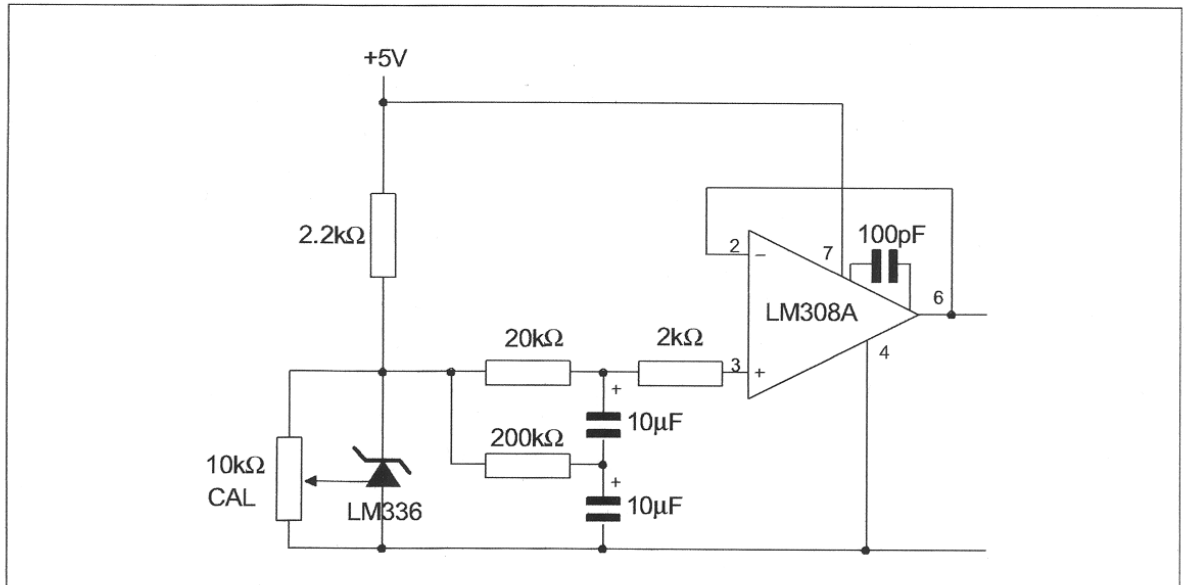

Figure 10 : Low Noise Buffered Reference



PACKAGE MECHANICAL DATA

SO-8 MECHANICAL DATA

DIM.	mm.			inch		
	MIN.	TYP.	MAX.	MIN.	TYP.	MAX.
A	1.35		1.75	0.053		0.069
A1	0.10		0.25	0.04		0.010
A2	1.10		1.65	0.043		0.065
B	0.33		0.51	0.013		0.020
C	0.19		0.25	0.007		0.010
D	4.80		5.00	0.189		0.197
E	3.80		4.00	0.150		0.157
e		1.27			0.050	
H	5.80		6.20	0.228		0.244
h	0.25		0.50	0.010		0.020
L	0.40		1.27	0.016		0.050
k	8° (max.)					
ddd			0.1			0.04

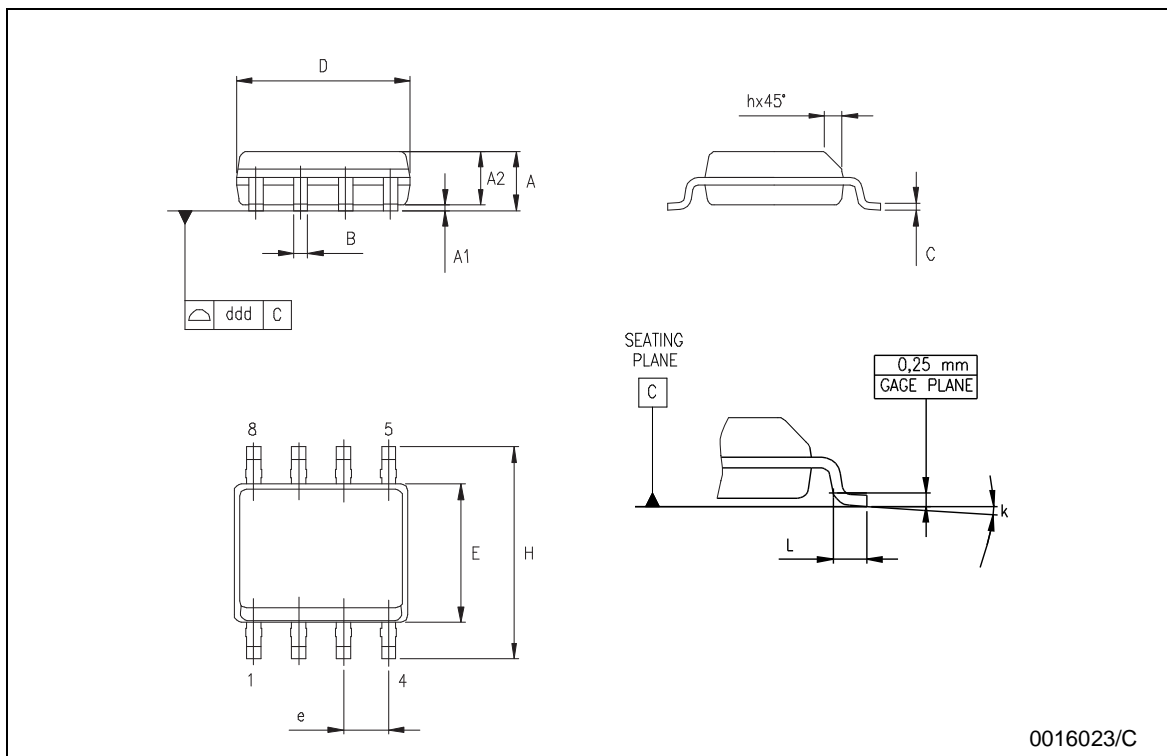

PACKAGE MECHANICAL DATA - TO92 TAPE AMMO PACK & TO92 TAPE & REEL

TO-92 MECHANICAL DATA

DIM.	mm.			inches		
	MIN.	TYP	MAX.	MIN.	TYP.	MAX.
AL			5.0			0.197
A			5.0			0.197
T			4.0			0.157
d		0.45			0.018	
l1	2.5			0.098		
P	11.7	12.7	13.7	0.461	0.500	0.539
PO	12.4	12.7	13	0.488	0.500	0.512
P2	5.95	6.35	6.75	0.234	0.250	0.266
F1/F2	2.4	2.5	2.8	0.094	0.098	0.110
h	-1	0	1	-0.039	0	0.039
P	-1	0	1	-0.039	0	0.039
W	17.5	18.0	19.0	0.689	0.709	0.748
W0	5.7	6	6.3	0.224	0.236	0.248
W1	8.5	9	9.75	0.335	0.354	0.384
W2			0.5			0.020
H			20			0.787
H0	15.5	16	16.5	0.610	0.630	0.650
H1			25			0.984
DO	3.8	4.0	4.2	0.150	0.157	0.165
L1			11			0.433

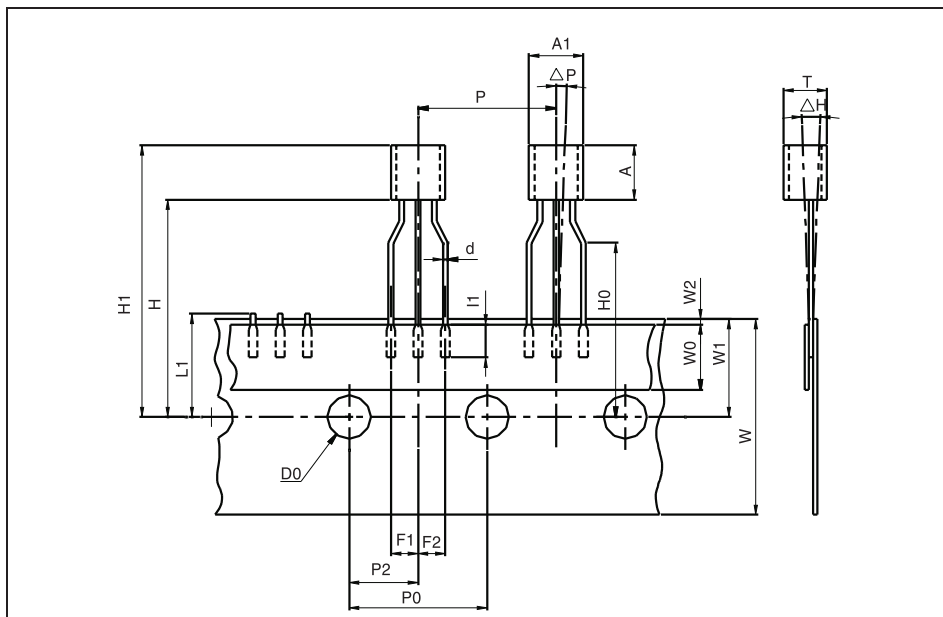

Packing information are available at: <http://www.st.com/stonline/prodpres/packages/stdlin.htm>

PACKAGE MECHANICAL DATA - TO92 BULK

TO-92 MECHANICA DATA

DIM.	mm.			mils		
	MIN.	TYP.	MAX.	MIN.	TYP.	MAX.
A	4.32		4.95	170.1		194.9
b	0.36		0.51	14.2		20.1
D	4.45		4.95	175.2		194.9
E	3.30		3.94	129.9		155.1
e	2.41		2.67	94.9		105.1
e1	1.14		1.40	44.9		55.1
L	12.7		15.49	500.0		609.8
R	2.16		2.41	85.0		94.9
S1	0.92		1.52	36.2		59.8
W	0.41		0.56	16.1		22.0

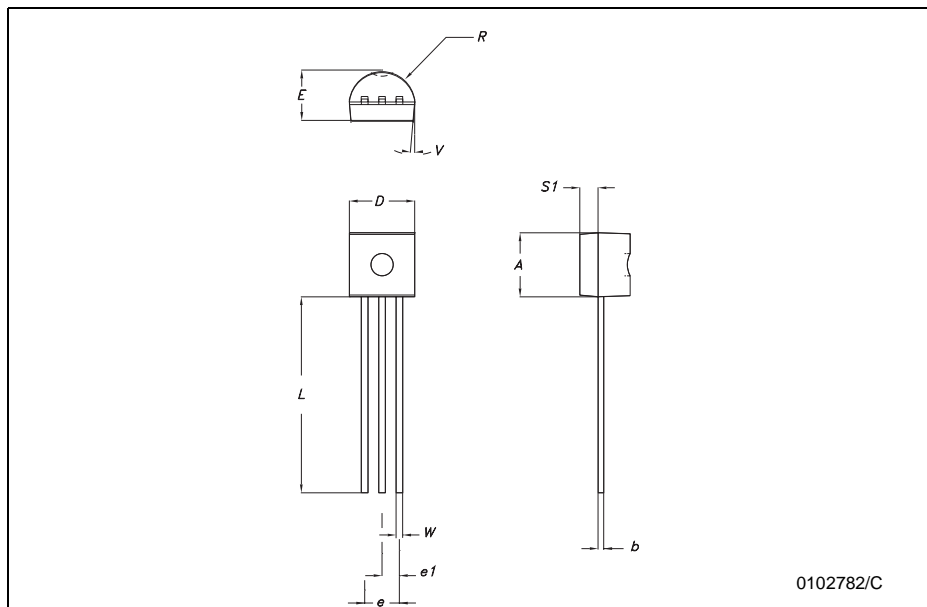

Packing information are available at: <http://www.st.com/stonline/prodpres/packages/stdlin.htm>

Information furnished is believed to be accurate and reliable. However, STMicroelectronics assumes no responsibility for the consequences of use of such information nor for any infringement of patents or other rights of third parties which may result from its use. No license is granted by implication or otherwise under any patent or patent rights of STMicroelectronics. Specifications mentioned in this publication are subject to change without notice. This publication supersedes and replaces all information previously supplied. STMicroelectronics products are not authorized for use as critical components in life support devices or systems without express written approval of STMicroelectronics.

The ST logo is a registered trademark of STMicroelectronics

© 2003 STMicroelectronics - All Rights Reserved
STMicroelectronics GROUP OF COMPANIES

Australia - Brazil - China - Finland - France - Germany - Hong Kong - India - Italy - Japan - Malaysia - Malta - Morocco
Singapore - Spain - Sweden - Switzerland - United Kingdom
<http://www.st.com>