



LT1076-5

5V Step-Down Switching Regulator

FEATURES

- Fixed 5V Output
- 2A On-Board Switch
- 100kHz Switching Frequency
- 2% Output Voltage Tolerance Over Temperature
- Greatly Improved Dynamic Behavior
- Available in Low Cost 5-Lead Package
- Only 9.5mA Quiescent Current
- Operates Up to 60V Input

APPLICATIONS

- 5V Output Buck Converter
- Tapped Inductor Buck Converter with 4A Output at 5V
- Positive-to-Negative Converter

DESCRIPTION

The LT1076-5 is a 2A fixed 5V output monolithic bipolar switching regulator which requires only a few external parts for normal operation. The power switch, all oscillator and control circuitry, all current limit components, and an output monitor are included on the chip. The topology is a classic positive “buck” configuration but several design innovations allow this device to be used as a positive-to-negative converter, a negative boost converter, and as a flyback converter. The switch output is specified to swing 40V below ground, allowing the LT1076-5 to drive a tapped inductor in the buck mode with output currents up to 4A.

The LT1076-5 uses a true analog multiplier in the feedback loop. This makes the device respond nearly instantaneously to input voltage fluctuations and makes loop gain independent of input voltage. As a result, dynamic behavior of the regulator is significantly improved over previous designs.

On-chip pulse by pulse current limiting makes the LT1076-5 nearly bust-proof for output overloads or shorts. The input voltage range as a buck converter is 8V to 60V, but a self-boot feature allows input voltages as low as 5V in the inverting and boost configurations.

The LT1076-5 is available in a low cost 5-lead TO-220 package with frequency pre-set at 100kHz and current limit at 2.6A. See Application Note 44 for design details.

TYPICAL APPLICATION

Basic Positive Buck Converter

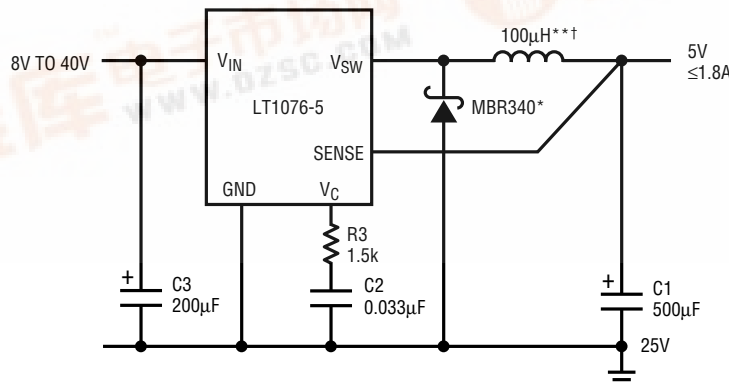

* MBR330P MAY BE USED FOR $V_{IN} \leq 25V$

** COILTRONICS #100-1-52 HURRICANE #HL-AG210LL

† VALUE MAY BE REDUCED TO 50µH FOR OUTPUT LOADS BELOW 1.5A



LT1076-5

ABSOLUTE MAXIMUM RATINGS

Input Voltage	
LT1076-5	45V
LT1076HV-5	64V
Switch Voltage with Respect to Input Voltage	
LT1076-5	64V
LT1076HV-5	75V
Switch Voltage with Respect to Ground Pin	
(V_{SW} Negative)	
LT1076-5 (Note 5)	35V
LT1076HV-5 (Note 5)	45V
Sense Pin Voltage	-2V, 10V
Maximum Operating Ambient Temperature Range	
LT1076C-5, LT1076HVC-5	0°C to 70°C
LT1076I-5, LT1076HVI-5	-40°C to 85°C
Maximum Operating Junction Temperature Range	
LT1076C-5, LT1076HVC-5	0°C to 125°C
LT1076I-5, LT1076HVI-5	-40°C to 125°C
Maximum Storage Temperature	-65°C to 150°C
Lead Temperature (Soldering, 10 sec)	300°C

PACKAGE/ORDER INFORMATION

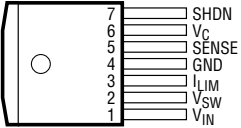
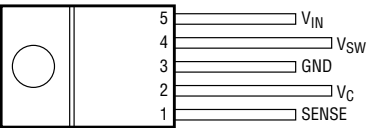
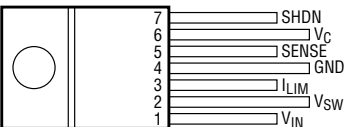
<p>FRONT VIEW</p>  <p>R PACKAGE 7-LEAD PLASTIC DD $T_{JMAX} = 110^{\circ}C$</p> <p>θ WILL VARY FROM APPROXIMATELY 30°C/W WITH 2.8IN² OF 1 OZ COPPER TO 70°C/W WITH 0.20IN² OF 1 OZ COPPER.</p>	<p>ORDER PART NUMBER</p> <p>LT1076CR-5</p>
<p>FRONT VIEW</p>  <p>T PACKAGE 5-LEAD TO-220 FOR STRAIGHT LEADS, ORDER FLOW 06 $T_{JMAX} = 110^{\circ}C$, $\theta_{JA} = 130^{\circ}C/W$</p>	<p>LT1076CT-5 LT1076HVCT-5 LT1076IT-5 LT1076HVIT-5</p>
<p>FRONT VIEW</p>  <p>Y PACKAGE 7-LEAD TO-220 $T_{JMAX} = 110^{\circ}C$, $\theta_{JA} = 130^{\circ}C/W$</p>	<p>LT1076CY-5</p>

Consult factory for Military grade parts.

ELECTRICAL CHARACTERISTICS $T_J = 25^{\circ}C$, $V_{IN} = 25V$, unless otherwise noted.

PARAMETER	CONDITIONS	MIN	TYP	MAX	UNITS
Switch "On" Voltage (Note 1)	$I_{SW} = 0.5A$	●		1.2	V
	$I_{SW} = 2A$	●		1.7	V
Switch "Off" Leakage	$V_{IN} = 25V$, $V_{SW} = 0$			150	μA
	$V_{IN} = V_{MAX}$, $V_{SW} = 0$ (Note 6)			250	μA
Supply Current (Note 2)	$V_{OUT} = 5.5V$, $V_{IN} \leq 40V$	●	8.5	11	$m A$
	$40V < V_{IN} < 60V$	●	9.0	12	$m A$
	$V_{SHDN} = 0.1V$ (Device Shutdown) (Note 8)		140	300	μA
Minimum Supply Voltage	Normal Mode	●	7.3	8.0	V
	Start-Up Mode (Note 3)	●	3.5	4.8	V
Switch Current Limit (Note 4)	$I_{LIM} = \text{Open}$	●	2	2.6	A
	$R_{LIM} = 10k$ (Note 9)			1.8	A
	$R_{LIM} = 7k$ (Note 9)			1.2	A
Maximum Duty Cycle		●	85	90	%

ELECTRICAL CHARACTERISTICS $T_J = 25^\circ\text{C}$, $V_{IN} = 25\text{V}$, unless otherwise noted.

PARAMETER	CONDITIONS	MIN	TYP	MAX	UNITS	
Switching Frequency	$T_J \leq 125^\circ\text{C}$ $V_{OUT} = V_{SENSE} = 0\text{V}$ (Note 4)	●	90	100	110	kHz
			85		120	kHz
				20		kHz
Switching Frequency Line Regulation	$8\text{V} \leq V_{IN} \leq V_{MAX}$ (Note 7)	●	0.03	0.1	%/V	
Error Amplifier Voltage Gain (Note 7)	$1\text{V} \leq V_C \leq 4\text{V}$		2000		V/V	
Error Amplifier Transconductance (Note 7)			3700	5000	8000	μmho
Error Amplifier Source and Sink Current	Source ($V_{SENSE} = 4.5\text{V}$) Sink ($V_{SENSE} = 5.5\text{V}$)		100	140	225	μA
			0.7	1.0	1.6	mA
Sense Pin Divider Resistance			3	5	8	k Ω
Sense Voltage	$V_C = 2\text{V}$	●	4.85	5	5.15	V
Output Voltage Tolerance	V_{OUT} (Nominal) = 5V All Conditions of Input Voltage, Output Voltage, Temperature and Load Current	●		± 0.5	± 2	%
				± 1.0	± 3	%
Output Voltage Line Regulation	$8\text{V} \leq V_{IN} \leq V_{MAX}$ (Note 6)	●	0.005	0.02		%/V
V_C Voltage at 0% Duty Cycle	Over Temperature	●		1.5		V
				-4.0		mV/ $^\circ\text{C}$
Multiplier Reference Voltage			24		V	
Shutdown Pin Current	$V_{SHDN} = 5\text{V}$ $V_{SHDN} \leq V_{THRESHOLD}$ ($\cong 2.5\text{V}$)		5	10	20	μA
					50	μA
Shutdown Thresholds	Switch Duty Cycle = 0 Fully Shut Down		2.2	2.45	2.7	V
			0.1	0.30	0.5	V
Thermal Resistance Junction to Case				4	$^\circ\text{C}/\text{W}$	

The ● denotes specifications which apply over the full operating temperature range.

Note 1: To calculate maximum switch “on” voltage at currents between low and high conditions, a linear interpolation may be used.

Note 2: A sense pin voltage (V_{SENSE}) of 5.5V forces the V_C pin to its low clamp level and the switch duty cycle to zero. This approximates the zero load condition where duty cycle approaches zero.

Note 3: Total voltage from V_{IN} pin to ground pin must be $\geq 8\text{V}$ after start-up for proper regulation. For $T_A < 25^\circ\text{C}$, limit = 5V.

Note 4: Switch frequency is internally scaled down when the sense pin voltage is less than 2.6V to avoid extremely short switch on times. During current limit testing, V_{SENSE} is adjusted to give a minimum switch on time of 1 μs .

Note 5: Switch to input voltage limitation must also be observed.

Note 6: $V_{MAX} = 40\text{V}$ for the LT1076-5 and 60V for the LT1076HV-5.

Note 7: Error amplifier voltage gain and transconductance are specified relative to the internal feedback node. To calculate gain and transconductance from the Sense pin (Output) to the V_C pin, multiply by 0.44.

Note 8: Does not include switch leakage.

Note 9: $I_{LIM} \approx \frac{R_{LIM} - 1\text{k}}{5\text{k}}$

LT1076-5

PACKAGE DESCRIPTION Dimensions in inches (millimeters) unless otherwise noted.

R Package, 7-Lead Plastic DD

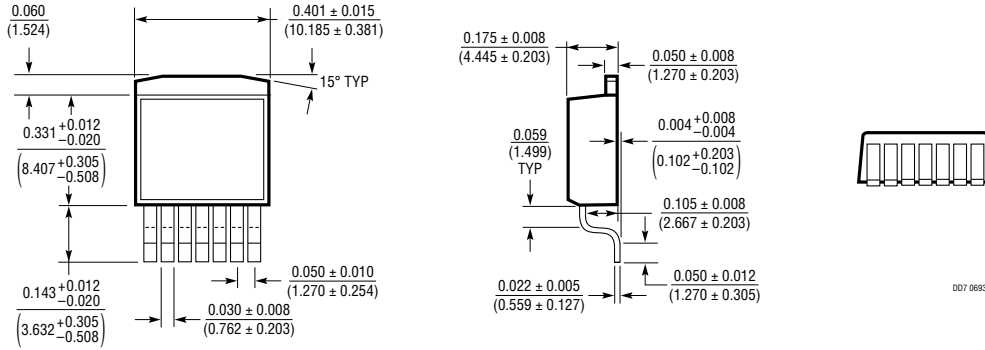

T Package, 5-Lead TO-220

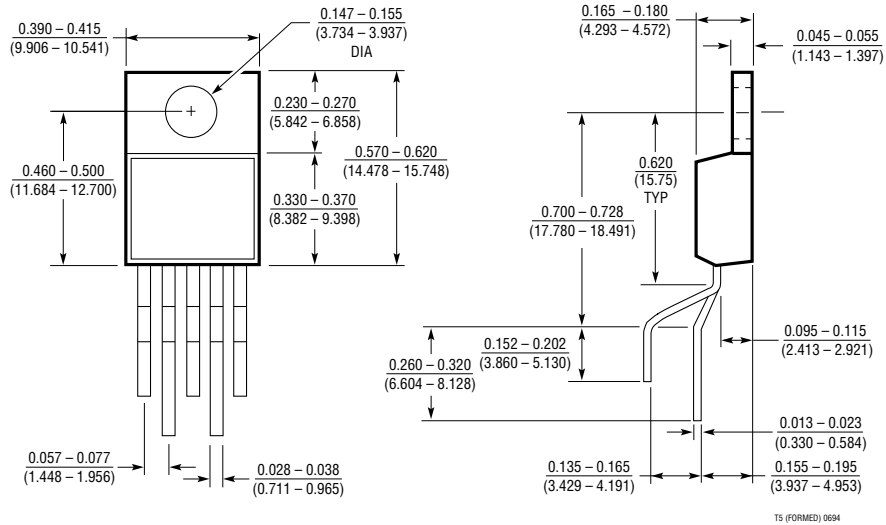

Y Package, 7-Lead TO-220

