



# LTC1555/LTC1556

## ABSOLUTE MAXIMUM RATINGS

(Note 1)

$V_{IN}$ , $DV_{CC}$ to GND .....	-0.3V to 12V
$V_{CC}$ to GND .....	-0.3V to 12V
Digital Inputs to GND .....	-0.3V to 12V
LDO, CLK, RST, I/O to GND .....	-0.3V to ( $V_{CC} + 0.3V$ )
$V_{CC}$ , LDO Short-Circuit Duration .....	Indefinite
Storage Temperature Range .....	-65°C to 150°C

Temperature Range

LTC1555C/LTC1556C .....	0°C to 70°C
LTC1555I/LTC1556I .....	-40°C to 85°C
Extended Commercial Operating Temperature Range (Note 2) .....	-40°C to 85°C
Lead Temperature (Soldering, 10 sec) .....	300°C

## PACKAGE/ORDER INFORMATION

TOP VIEW	ORDER PART NUMBER	TOP VIEW	ORDER PART NUMBER
<p>GN PACKAGE 16-LEAD PLASTIC SSOP <math>T_{JMAX} = 150^{\circ}C</math>, <math>\theta_{JA} = 135^{\circ}C/W</math></p>	<p>LTC1555CGN LTC1555IGN</p>	<p>GN PACKAGE 20-LEAD PLASTIC SSOP <math>T_{JMAX} = 150^{\circ}C</math>, <math>\theta_{JA} = 95^{\circ}C/W</math></p>	<p>LTC1556CGN LTC1556IGN</p>

Consult factory for Military grade parts.

## ELECTRICAL CHARACTERISTICS

$V_{IN} = 2.7V$  to  $10V$ ,  $DV_{CC} = 1.8V$  to  $5.5V$ , controller digital pins tied to  $DV_{CC}$ , SIM digital pins floating, EN, FB pins tied to GND (LTC1556),  $C1 = 0.1\mu F$ ,  $C_{OUT} = 10\mu F$  unless otherwise specified.

PARAMETER	CONDITIONS	MIN	TYP	MAX	UNITS	
$V_{IN}$ Operating Voltage		●	2.7	10	V	
$DV_{CC}$ Operating Voltage		●	1.8	5.5	V	
$V_{IN}$ Operating Current	$2.7V \leq V_{IN} \leq 5V$ , $V_{CC} = 5V$ , $I_{VCC} = 0$	●	60	100	$\mu A$	
	$5V < V_{IN} \leq 10V$ , $V_{CC} = 5V$ , $I_{VCC} = 0$	●	75	135	$\mu A$	
$V_{IN}$ Shutdown Current	$M0, M1 = 0V$ , $2.7V \leq V_{IN} \leq 5V$			1	$\mu A$	
	$M0, M1 = 0V$ , $2.7V \leq V_{IN} \leq 5V$	●		2	$\mu A$	
	$M0, M1 = 0V$ , $5V < V_{IN} \leq 10V$			25	$\mu A$	
$DV_{CC}$ Operating Current	$M0, M1 = DV_{CC}$ , $C_{IN} = 1MHz$	●	6	20	$\mu A$	
$DV_{CC}$ Shutdown Current	$M0, M1 = 0V$	●		1	$\mu A$	
$V_{CC}$ Output Voltage	$0 \leq I_{VCC} \leq 10mA$ , $2.7V \leq V_{IN} \leq 10V$	●	4.75	5.00	5.25	V
	$0 \leq I_{VCC} \leq 20mA$ , $3V \leq V_{IN} \leq 10V$	●	2.80	3.00	3.20	V
	$M0 = DV_{CC}$ , $M1 = 0$	●				V
	$M0 = 0$ , $M1 = DV_{CC}$	●	$V_{IN} - 0.3$		$V_{IN}$	V
$V_{CC}$ Output Ripple	$V_{IN} = 3.6V$ , $I_{VCC} = 10mA$ , $V_{CC} = 5V$		75		mV <sub>P-P</sub>	

## ELECTRICAL CHARACTERISTICS

$V_{IN} = 2.7V$  to  $10V$ ,  $DV_{CC} = 1.8V$  to  $5.5V$ , controller digital pins tied to  $DV_{CC}$ , SIM digital pins floating, EN, FB pins tied to GND (LTC1556),  $C_1 = 0.1\mu F$ ,  $C_{OUT} = 10\mu F$  unless otherwise specified.

PARAMETER	CONDITIONS		MIN	TYP	MAX	UNITS
$V_{CC}$ Short-Circuit Current	$V_{CC}$ Shorted to GND	●		12.5	40	mA
Auxiliary LDO $V_{OUT}$ ( $V_{LDO}$ )	EN = High, $V_{CC} = 5V$ , FB = LDO, $I_{LDO} = 5mA$ (LTC1556)	●	4.00	4.3	4.55	V
Auxiliary Switch Resistance	EN = High, $V_{CC} = 5V$ , FB = GND (LTC1556)	●		18	30	$\Omega$
FB Input Resistance	(LTC1556)			200		$k\Omega$
Charge Pump $f_{OSC}$		●	500	650	800	kHz
<b>Controller Inputs/Outputs, <math>DV_{CC} = 3V</math></b>						
Input Current ( $I_{IH}$ , $I_{IL}$ )	M0, M1, $\overline{SS}$ , RIN, CIN DDRV, EN	●	-1		1	$\mu A$
		●	-5		5	$\mu A$
High Level Input Current ( $I_{IH}$ )	DATA	●	-20		20	$\mu A$
Low Level Input Current ( $I_{IL}$ )	DATA	●			1	mA
High Input Voltage Threshold ( $V_{IH}$ )	M0, M1, RIN, CIN, DDRV, EN DATA	●			$0.7 \times DV_{CC}$	V
		●			$DV_{CC} - 0.6$	V
Low Input Voltage Threshold ( $V_{IL}$ )	M0, M1, RIN, CIN, DDRV, EN DATA	●	$0.2 \times DV_{CC}$			V
		●	0.4			V
High Level Output Voltage ( $V_{OH}$ )	DATA Source Current = $20\mu A$ , I/O = $V_{CC}$	●	$0.7 \times DV_{CC}$			V
Low Level Output Voltage ( $V_{OL}$ )	DATA Sink Current = $-200\mu A$ , I/O = 0V (Note 3)	●			0.4	V
DATA Pull-up Resistance	Between DATA and $DV_{CC}$	●	13	20	28	$k\Omega$
DATA Output Rise/Fall Time	DATA Loaded with 30pF	●		1.3	2	$\mu s$
<b>SIM Inputs/Outputs, <math>DV_{CC} = 3V</math>, <math>V_{CC} = 3V</math> or <math>5V</math></b>						
I/O High Input Voltage Threshold ( $V_{IH}$ )	$I_{IH(MAX)} = \pm 20\mu A$	●		$0.5 \times V_{CC}$	$0.7 \times V_{CC}$	V
I/O Low Input Voltage Threshold ( $V_{IL}$ )	$I_{IL(MAX)} = 1mA$	●	0.4			V
High Level Output Voltage ( $V_{OH}$ )	I/O, Source Current = $20\mu A$ , DATA or DDRV = $DV_{CC}$ RST, CLK, Source Current = $20\mu A$	●		$0.8 \times V_{CC}$		V
		●		$0.9 \times V_{CC}$		V
Low Level Output Voltage ( $V_{OL}$ )	I/O, Sink Current = $-1mA$ , DATA or DDRV = 0V (Note 3) RST, CLK, Sink Current = $-200\mu A$	●			0.4	V
		●			0.4	V
I/O Pull-Up Resistance	Between I/O and $V_{CC}$	●	6.5	10	14	$k\Omega$
<b>SIM Timing Parameters, <math>DV_{CC} = 3V</math>, <math>V_{CC} = 5V</math></b>						
CLK Rise/Fall Time	CLK Loaded with 30pF	●			18	ns
RST, I/O Rise/Fall Time	RST, I/O Loaded with 30pF	●			1	$\mu s$
CLK Frequency	CLK Loaded with 30pF	●			5	MHz
$V_{CC}$ Turn-On Time	$\overline{SS} = DV_{CC}$ , $C_{OUT} = 10\mu F$ , $I_{VCC} = 0$ $\overline{SS} = 0V$ , $C_{OUT} = 10\mu F$ , $I_{VCC} = 0$			1		ms
				6		ms
$V_{CC}$ Discharge Time to 1V	$I_{VCC} = 0$ , $V_{CC} = 5V$ , $C_{OUT} = 10\mu F$			3		ms

The ● denotes specifications which apply over the specified temperature range.

**Note 1:** Absolute Maximum Ratings are those values beyond which the life of a device may be impaired.

**Note 2:** C grade device specifications are guaranteed over the  $0^\circ C$  to  $70^\circ C$  temperature range. In addition, C grade device specifications are assured

over the  $-40^\circ C$  to  $85^\circ C$  temperature range by design or correlation, but are not production tested.

**Note 3:** The DATA and I/O pull-down drivers must also sink current sourced by the internal pull-up resistors.

# LTC1555/LTC1556

## TYPICAL PERFORMANCE CHARACTERISTICS

**Operating Current vs Input Voltage**

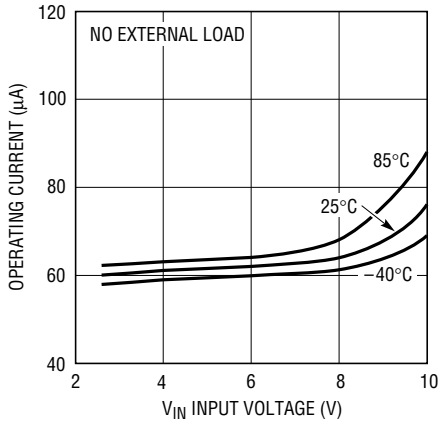

**Shutdown Current vs Input Voltage**

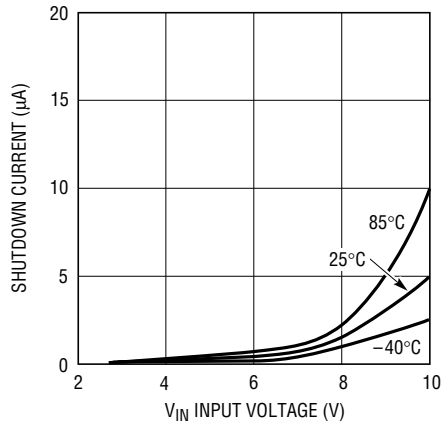

**V<sub>CC</sub> Output Voltage vs Input Voltage (5V Mode)**

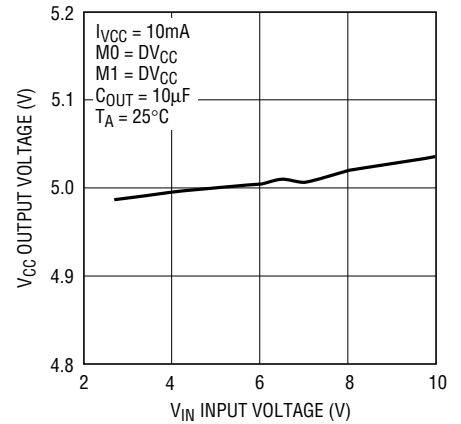

**V<sub>CC</sub> Output Voltage vs Input Voltage (3V Mode)**

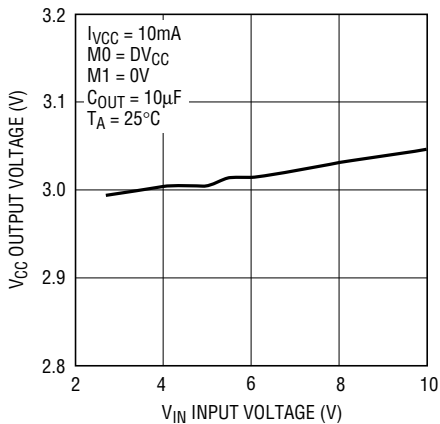

**V<sub>CC</sub> Output Voltage Turn-On Time, SS Enabled**

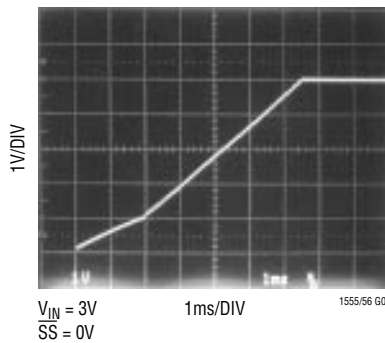

**V<sub>CC</sub> Output Voltage Turn-On Time, SS Disabled**

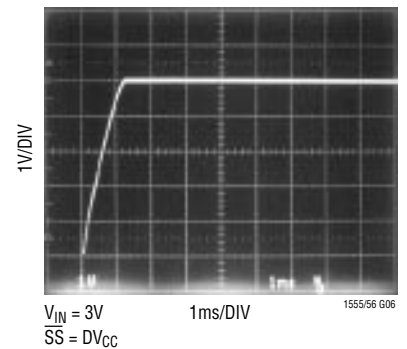

**3V V<sub>CC</sub> Efficiency vs Input Voltage**

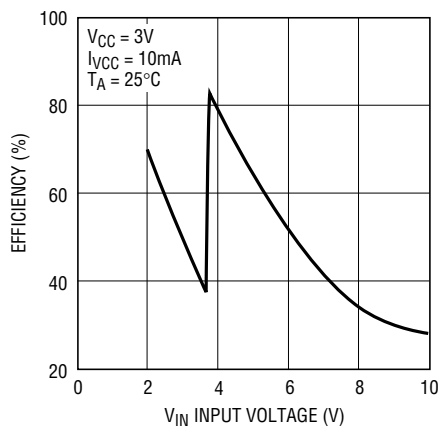

**5V V<sub>CC</sub> Efficiency vs Input Voltage**

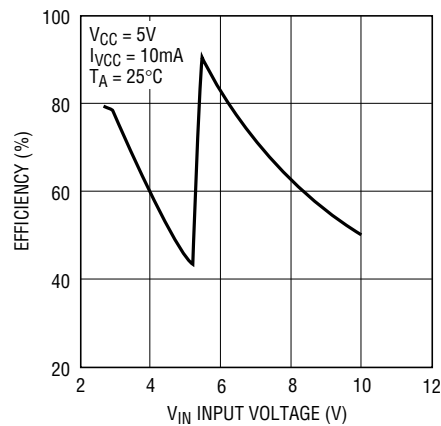

## PIN FUNCTIONS

### LTC1555/LTC1556

**CIN (Pin 1):** Clock Input Pin from Controller.

**RIN (Pin 2):** Reset Input Pin from Controller.

**DATA (Pin 3):** Controller Side Data Input/Output Pin. Can be used for single pin bidirectional data transfer between the controller and the SIM card as long as the controller data pin is open drain. The controller output must be able to sink 1mA max when driving the DATA pin low due to the internal pull-up resistors on the DATA and I/O pins. If the controller data output is not open drain, then the DDRV pin should be used for sending data to the SIM card and the DATA pin used for receiving data from the SIM card (see Figure 1).

**DDRV (Pin 4):** Optional Data Input Pin for Sending Data to the SIM card. When not needed, the DDRV pin should be left floating or tied to DV<sub>CC</sub> (an internal 1μA current source will pull the DDRV pin up to DV<sub>CC</sub> if left floating).

**DV<sub>CC</sub> (Pins 5/7):** Supply Voltage for Controller Side Digital I/O Pins. May be between 1.8V and 5.5V (typically 3V).

**SS (Pins 6/8):** Soft Start Enable Pin. A logic low will enable the charge pump inrush current limiting feature. A logic high will disable the soft start feature and allow V<sub>CC</sub> to be ramped as quickly as possible upon start-up and coming out of shutdown.

**M1 (Pins 7/9):** Mode Control Bit 1 (see Truth Table).

**M0 (Pins 8/10):** Mode Control Bit 0 (see Truth Table).

This table defines the various operating modes that may be obtained via the M0 and M1 mode control pins.

**Truth Table**

M0	M1	MODE
0V	0V	Shutdown (V <sub>CC</sub> = 0V)
0V	DV <sub>CC</sub>	V <sub>CC</sub> = V <sub>IN</sub>
DV <sub>CC</sub>	0V	V <sub>CC</sub> = 3V
DV <sub>CC</sub>	DV <sub>CC</sub>	V <sub>CC</sub> = 5V

**GND (Pins 9/11, 12):** Ground for Both the SIM and the Controller. Should be connected to the SIM GND contact as well as to the V<sub>IN</sub>/Controller GND. Proper grounding and supply bypassing is required to meet 10kV ESD specifications.

**C1<sup>-</sup> (Pins 10/12):** Charge Pump Flying Capacitor Negative Input.

**C1<sup>+</sup> (Pins 11/13):** Charge Pump Flying Capacitor Positive Input.

**V<sub>IN</sub> (Pins 12/14):** Charge Pump Input Voltage Pin. Input voltage range is 2.7V to 10V. Connect a 10μF low ESR input bypass capacitor close to the V<sub>IN</sub> pin.

**V<sub>CC</sub> (Pins 13/15):** SIM Card V<sub>CC</sub> Output. This pin should be connected to the SIM V<sub>CC</sub> contact. The V<sub>CC</sub> output voltage is determined by the M0 and M1 pins (see Truth Table). V<sub>CC</sub> is discharged to GND during shutdown (M0, M1 = 0V). A 10μF low ESR output capacitor should connect close to the V<sub>CC</sub> pin.

**I/O (Pins 14/18):** SIM Side I/O Pin. The pin is an open drain output with a nominal pull-up resistance of 10k and should be connected to the SIM I/O contact. The SIM card must sink up to 1mA max when driving the I/O pin low due to the internal pull-up resistors on the I/O and DATA pins. The I/O pin is held active low when the part is in shutdown.

**RST (Pins 15/19):** Level Shifted Reset Output Pin. Should be connected to the SIM RST contact.

**CLK (Pins 16/20):** Level Shifted Clock Output Pin. Should be connected to the SIM CLK contact. Careful trace routing is recommended due to fast rise and fall edge speeds.

# LTC1555/LTC1556

## PIN FUNCTIONS

### LTC1556 Only

**EN (Pin 5):** Auxiliary LDO/Power Switch Enable Pin. A logic high on this pin from the controller will enable the auxiliary LDO output. When the LDO is disabled, the LDO output will float or be pulled to ground by the load. If left floating, the EN pin will be pulled down to GND by an internal  $1\mu\text{A}$  current source.

**FB (Pin 6):** Auxiliary LDO Feedback Pin. When FB is connected to the LDO pin (Pin 17), the LDO output is regulated to 4.3V (typ). If the FB pin is left open or tied to

ground, the regulator acts as a  $\leq 30\Omega$  switch between  $V_{CC}$  and LDO.

**LDO (Pin 17):** LDO Output Pin. This pin should be tied to the FB pin for 4.3V LDO operation. The 4.3V LDO output is usable only when  $V_{CC}$  is 5V (or greater). It is not available when  $V_{CC} = 3\text{V}$ . The LDO output may also be used as a  $\leq 30\Omega$  power switch if the FB pin is grounded or left floating. When used as a regulator, LDO must be bypassed to GND with a  $\geq 3.3\mu\text{F}$  capacitor. The LDO output current will subtract from available  $V_{CC}$  current.

## BLOCK DIAGRAM

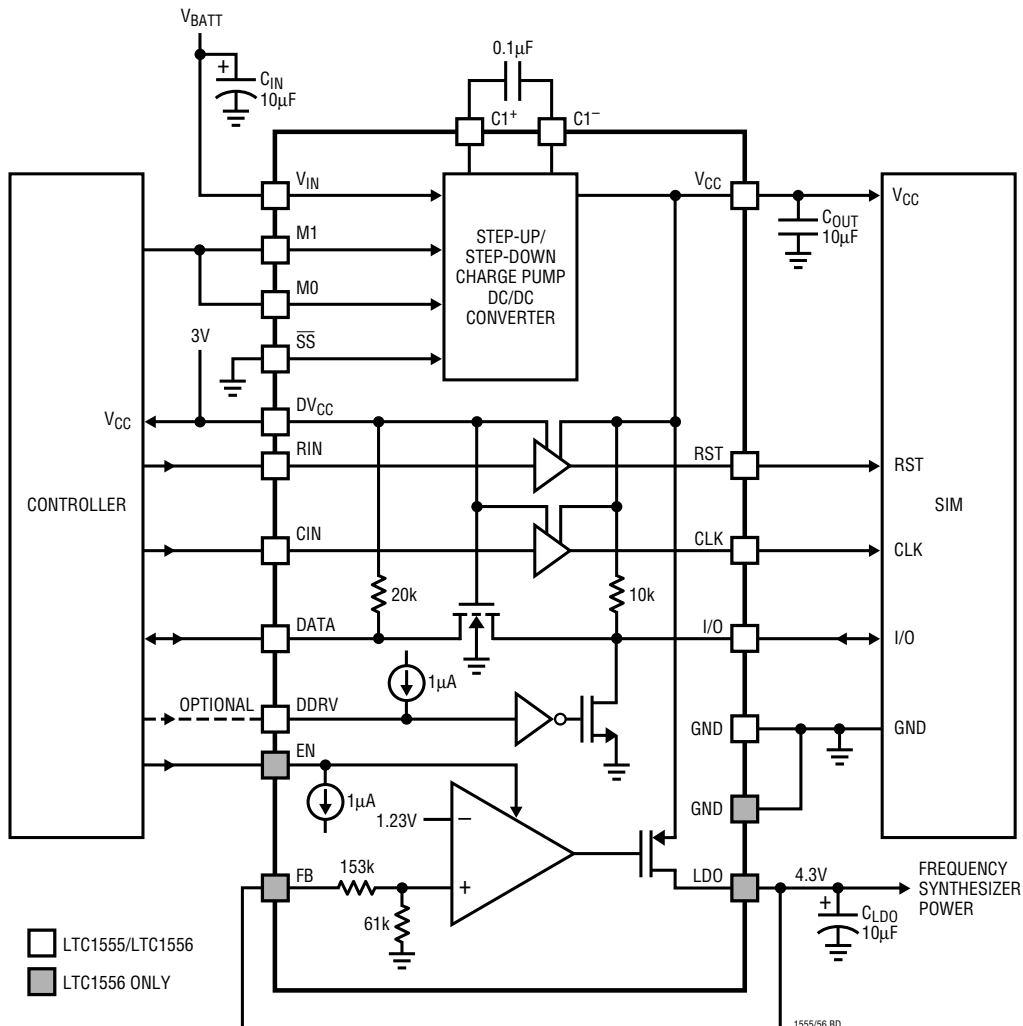

## APPLICATIONS INFORMATION

The LTC1555/LTC1556 perform the two primary functions necessary for 3V controllers (e.g., GSM cellular telephone controllers, smart card readers, etc.) to communicate with 5V SIMs or smart cards. They produce a regulated 5V  $V_{CC}$  supply for the SIM and provide level translators for communication between the SIM and the controller.

### $V_{CC}$ Voltage Regulator

The regulator section of the LTC1555/LTC1556 (refer to the Block Diagram) consists of a step-up/step-down charge pump DC/DC converter. The charge pump can operate over a wide input voltage range (2.7V to 10V) while maintaining a regulated  $V_{CC}$  output. The wide  $V_{IN}$  range enables the parts to be powered directly from a battery (if desired) rather than from a 3V DC/DC converter output. When  $V_{IN}$  is less than the desired  $V_{CC}$  the parts operate as switched capacitor voltage doublers. When  $V_{IN}$  is greater than  $V_{CC}$  the parts operate as gated switch step-down converters. In either case, voltage conversion requires only one small flying capacitor and output capacitor.

The  $V_{CC}$  output can be programmed to either 5V or 3V via the M0 and M1 mode pins. This feature is useful in applications where either a 5V or 3V SIM may be used. The charge pump  $V_{CC}$  output may also be connected directly to  $V_{IN}$  if desired. When the charge pump is put into shutdown (M0, M1 = 0),  $V_{CC}$  is pulled to GND via an internal switch to aid in proper system supply sequencing.

The soft start feature limits inrush currents upon start-up or coming out of shutdown mode. When the  $\overline{SS}$  pin is tied to GND, the soft start feature is enabled. This limits the effective inrush current out of  $V_{IN}$  to approximately 25mA ( $C_{OUT} = 10\mu\text{F}$ ). Inrush current limiting is especially useful when powering the LTC1555/LTC1556 from a 3V DC/DC output since the unlimited inrush current may approach 200mA and cause voltage transients on the 3V supply. However, in cases where fast turn-on time is desired, the soft start feature may be overridden by tying the  $\overline{SS}$  pin to  $DV_{CC}$ .

### Capacitor Selection

For best performance, it is recommended that low ESR ( $< 0.5\Omega$ ) capacitors be used for both  $C_{IN}$  and  $C_{OUT}$  to reduce noise and ripple. The  $C_{IN}$  and  $C_{OUT}$  capacitors should be either ceramic or tantalum and should be  $10\mu\text{F}$  or greater (ceramic capacitors will produce the smallest output ripple). If the input source impedance is very low ( $< 0.5\Omega$ ),  $C_{IN}$  may not be needed. Increasing the size of  $C_{OUT}$  to  $22\mu\text{F}$  or greater will reduce output voltage ripple—particularly with high  $V_{IN}$  voltages (8V or greater). A ceramic capacitor is recommended for the flying capacitor C1 with a value of  $0.1\mu\text{F}$  or  $0.22\mu\text{F}$ .

### Output Ripple

Normal LTC1555/LTC1556 operation produces voltage ripple on the  $V_{CC}$  pin. Output voltage ripple is required for the parts to regulate. Low frequency ripple exists due to the hysteresis in the sense comparator and propagation delays in the charge pump enable/disable circuits. High frequency ripple is also present mainly from the ESR (equivalent series resistance) in the output capacitor. Typical output ripple ( $V_{IN} < 8\text{V}$ ) under maximum load is 75mV peak-to-peak with a low ESR,  $10\mu\text{F}$  output capacitor. For applications requiring  $V_{IN}$  to exceed 8V, a  $22\mu\text{F}$  or larger  $C_{OUT}$  capacitor is recommended to maintain maximum ripple in the 75mV range.

The magnitude of the ripple voltage depends on several factors. High input voltages increase the output ripple since more charge is delivered to  $C_{OUT}$  per charging cycle. A large C1 flying capacitor ( $> 0.22\mu\text{F}$ ) also increases ripple in step-up mode for the same reason. Large output current load and/or a small output capacitor ( $< 10\mu\text{F}$ ) results in higher ripple due to higher output voltage  $dV/dt$ . High ESR capacitors ( $\text{ESR} > 0.5\Omega$ ) on the output pin cause high frequency voltage spikes on  $V_{OUT}$  with every clock cycle.

A  $10\mu\text{F}$  ceramic capacitor on the  $V_{CC}$  pin should produce acceptable levels of output voltage ripple in nearly all applications. However, there are several ways to further

# LTC1555/LTC1556

## APPLICATIONS INFORMATION

reduce the ripple. A larger  $C_{OUT}$  capacitor (22 $\mu$ F or greater) will reduce both the low and high frequency ripple due to the lower  $C_{OUT}$  charging and discharging  $dV/dt$  and the lower ESR typically found with higher value (larger case size) capacitors. A low ESR ceramic output capacitor will minimize the high frequency ripple, but will not reduce the low frequency ripple unless a high capacitance value is chosen (10 $\mu$ F or greater). A reasonable compromise is to use a 10 $\mu$ F to 22 $\mu$ F tantalum capacitor in parallel with a 1 $\mu$ F to 3.3 $\mu$ F ceramic capacitor on  $V_{OUT}$  to reduce both the low and high frequency ripple. An RC filter may also be used to reduce high frequency voltage spikes (see Figure 1).

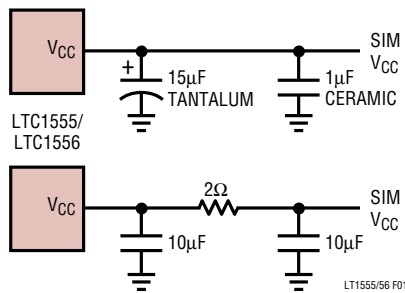

Figure 1.  $V_{CC}$  Output Ripple Reduction Techniques

### Shutting Down the $DV_{CC}$ Supply

To conserve power, the  $DV_{CC}$  supply may be shut down while the  $V_{IN}$  supply is still active. When the  $DV_{CC}$  supply is brought to 0V, weak internal currents will force the LTC1555/LTC1556 into shutdown mode regardless of the voltages present on the M0 and M1 pins. However, if the M0 and M1 pins are floating or left connected to  $DV_{CC}$  as the supply is shut down, the parts may take several

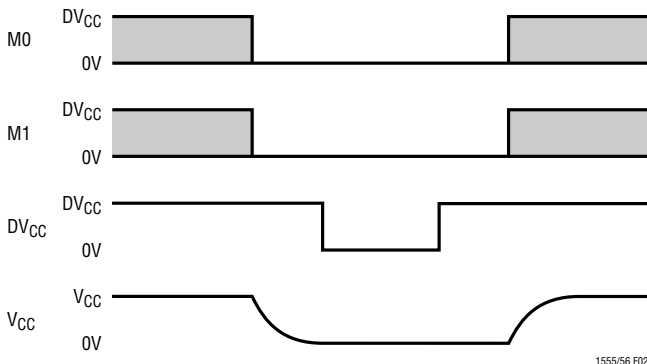

Figure 2. Recommended  $DV_{CC}$  Shutdown and Start-Up Timing

hundred milliseconds to completely shut down. To ensure prompt and proper  $V_{CC}$  shutdown, always force the M0 and M1 pins to a logic low state before shutting down the  $DV_{CC}$  supply (see Figure 2). Similarly, bring the  $DV_{CC}$  supply to a valid level before allowing the M0 and M1 pins to go high when coming out of shutdown. This can be achieved with pull-down resistors from M0 and M1 to GND if necessary. (Note: shutting down the  $DV_{CC}$  supply with  $V_{IN}$  active is not recommended with early date code material. Consult factory for valid date code starting point for shutting down the  $DV_{CC}$  supply.)

### Level Translators

All SIMs and smart cards contain a clock input, reset input and a bidirectional data input/output. The LTC1555/LTC1556 provide level translators to allow controllers to communicate with the SIM (see Figures 3a and 3b). The CLK and RST inputs to the SIM are level shifted from the controller supply rails ( $DV_{CC}$  and GND) to the SIM supply rails ( $V_{CC}$  and GND). The data input to the SIM may be provided two different ways. The first method is to use the DATA pin as a bidirectional level translator. This configuration is only allowed if the controller data output pin is open drain (all SIM I/O pins are open drain). Internal pull-up resistors are provided for both the DATA pin and the

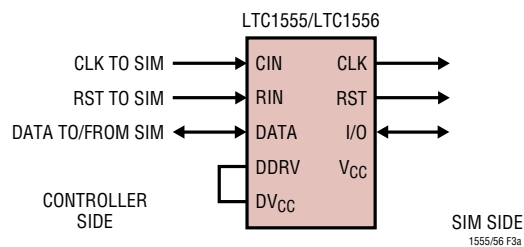

Figure 3a. Level Translator Connections for Bidirectional Controller DATA Pin

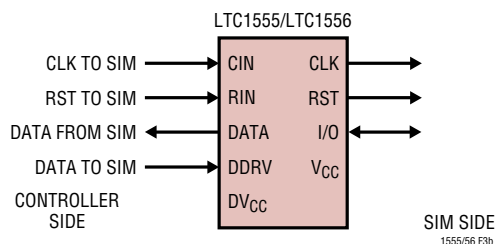

Figure 3b. Level Translator Connections for One-Directional Controller Side DATA Flow



## APPLICATIONS INFORMATION

I/O pin on the SIM side. The second method is to use the DDRV pin to send data to the SIM and use the DATA pin to receive data from the SIM. When the DDRV pin is not used, it should either be left floating or tied to  $DV_{CC}$ .

### Level Translation with $DV_{CC} > V_{CC}$

It is assumed that most applications for these parts will use controller supply voltages ( $DV_{CC}$ ) less than or equal to  $V_{CC}$ . In cases where  $DV_{CC}$  is greater than  $V_{CC}$  by more than 0.6V or so, the parts' operation will be affected in the following ways: 1) A small DC current (up to 100 $\mu$ A) will flow from  $DV_{CC}$  to  $V_{CC}$  through the DATA pull-up resistor, N-channel pass device and the I/O pull-up resistor (except when the part is in shutdown at which time  $DV_{CC}$  is disconnected from  $V_{CC}$  by turning off the pass device). If the  $V_{CC}$  load current is less than the  $DV_{CC}$  current, the  $V_{CC}$  output may be pulled out of regulation until sufficient load current pulls  $V_{CC}$  back into regulation. 2) When the SIM is sending data back to the controller, a logic high on the I/O pin will result in the DATA pin being pulled up to  $[V_{CC} + 1/3(DV_{CC} - V_{CC})]$ , not all the way up to  $DV_{CC}$ . For example, if  $DV_{CC}$  is 5V and  $V_{CC}$  is 3V, the DATA pin will only swing from  $\approx 0.1V$  to 3.67V when receiving data from the SIM side.

### Optional LDO Output

The LTC1556 also contains an internal LDO regulator for providing a low noise boosted supply voltage for low power external circuitry (e.g., frequency synthesizers, etc.) Tying the FB pin to the LDO pin provides a regulated 4.3V at the LDO output (see Figure 4). A 3.3 $\mu$ F (minimum) capacitor is

required to ensure output stability. A 10 $\mu$ F low ESR capacitor is recommended, however, to minimize LDO output noise. The LDO output may also be used as an auxiliary switch to  $V_{CC}$ . If the FB pin is left floating or is tied to GND, the LDO pin will be internally connected to the  $V_{CC}$  output through the P-channel pass device. The LDO may be disabled at any time by switching the EN pin from  $DV_{CC}$  to GND. The 4.3V LDO output is usable only when  $V_{CC}$  is 5V (or greater). It is not available when  $V_{CC} = 3V$ .

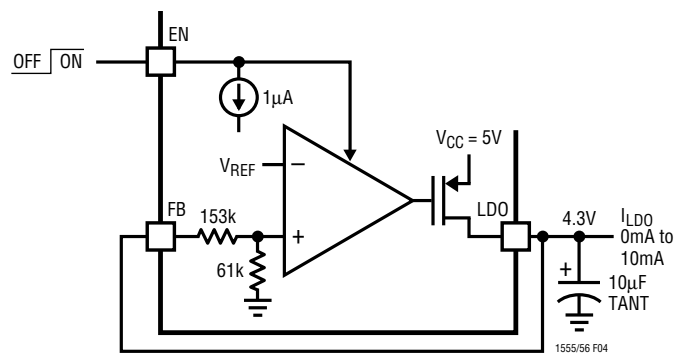

Figure 4. Auxiliary LDO Connections (LTC1556 Only)

### 10kV ESD Protection

All pins that connect to the SIM (CLK, RST, I/O,  $V_{CC}$ , GND) withstand over 10kV of human body model (100pF/1.5k $\Omega$ ) ESD. In order to ensure proper ESD protection, careful board layout is required. The GND pins should be tied directly to a GND plane. The  $V_{CC}$  capacitor should be located very close to the  $V_{CC}$  pin and tied immediately to the GND plane.

# LTC1555/LTC1556

## PACKAGE DESCRIPTION Dimensions in inches (millimeters) unless otherwise noted.

### GN Package 16-Lead Plastic SSOP (Narrow 0.150) (LTC DWG # 05-08-1641)

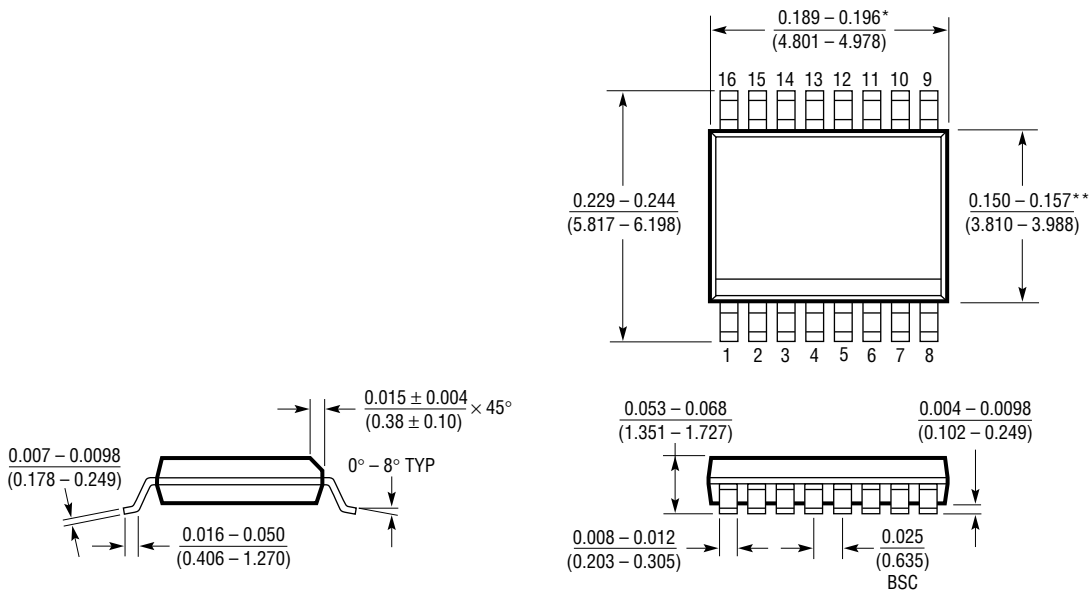

\* DIMENSION DOES NOT INCLUDE MOLD FLASH. MOLD FLASH SHALL NOT EXCEED 0.006" (0.152mm) PER SIDE

\*\* DIMENSION DOES NOT INCLUDE INTERLEAD FLASH. INTERLEAD FLASH SHALL NOT EXCEED 0.010" (0.254mm) PER SIDE

GN16 (SSOP) 1197

**PACKAGE DESCRIPTION** Dimensions in inches (millimeters) unless otherwise noted.

**GN Package**  
**20-Lead Plastic SSOP (Narrow 0.150)**  
 (LTC DWG # 05-08-1641)

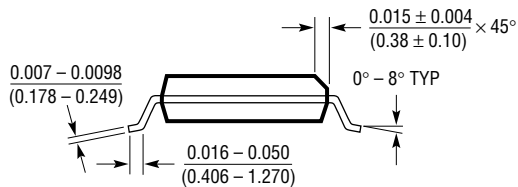
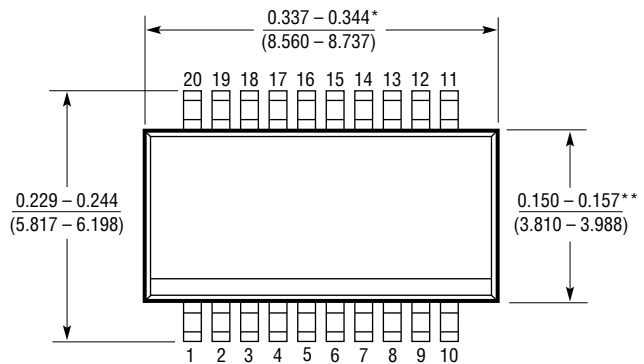

\* DIMENSION DOES NOT INCLUDE MOLD FLASH. MOLD FLASH SHALL NOT EXCEED 0.006" (0.152mm) PER SIDE

\*\* DIMENSION DOES NOT INCLUDE INTERLEAD FLASH. INTERLEAD FLASH SHALL NOT EXCEED 0.010" (0.254mm) PER SIDE

GN20 (SSOP) 1197

# LTC1555/LTC1556

## TYPICAL APPLICATION

SIM Interface with Auxiliary Power

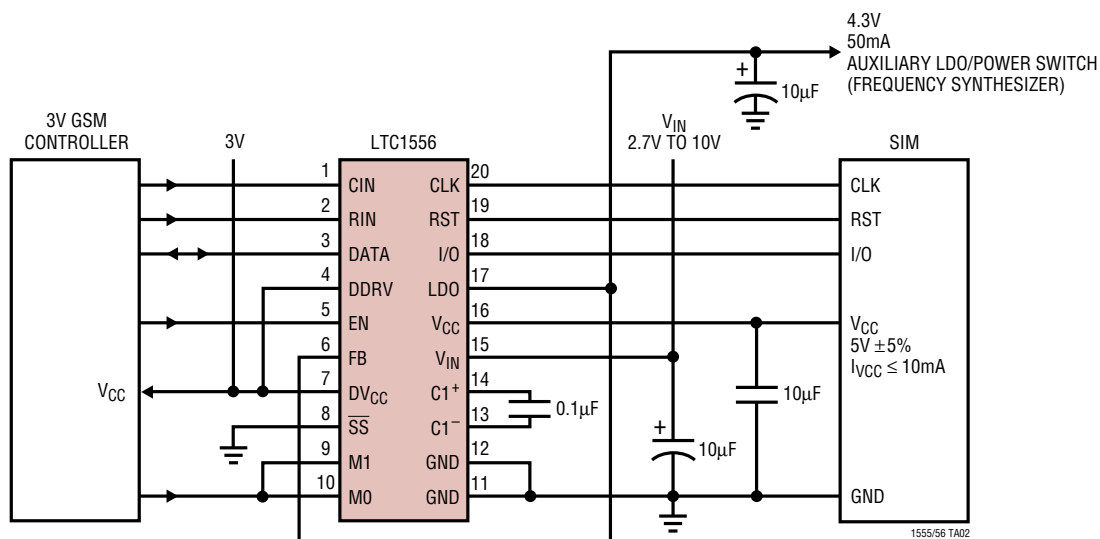

## RELATED PARTS

PART NUMBER	DESCRIPTION	COMMENTS
LTC1514-3.3/LTC1514-5	Regulated Step-Up/Step-Down Charge Pumps with Low Bat Comparator	3.3V and 5V Output Versions
LTC1515 Series	Regulated Step-Up/Step-Down Charge Pumps with Reset Output	Adjustable, 3V/5V, 3.3V/5V Versions
LTC1516	Micropower, Regulated 5V Charge Pump DC/DC Converter	$I_{OUT} = 20mA$ ( $V_{IN} \geq 2V$ ), $I_{OUT} = 50mA$ ( $V_{IN} \geq 3V$ )
LTC1517-5	Micropower, Regulated 5V Charge Pump DC/DC Converter	LTC1522 Without Shutdown and Packaged in SOT-23
LTC1522	Micropower, Regulated 5V Charge Pump DC/DC Converter	$I_{OUT} = 20mA$ ( $V_{IN} \geq 3V$ ), $I_Q = 6\mu A$
LTC1550-4.1	Low Noise, Charge Pump Voltage Inverter	1mV <sub>p-p</sub> Ripple at 900kHz
LTC660	100mA Charge Pump DC/DC Converter	5V to -5V at 100mA