

> **Features**

- High Current
- Low On-Resistance
- No Secondary Breakdown
- Low Driving Power
- Avalanche Rated

> **Applications**

- Motor Control
- General Purpose Power Amplifier
- DC-DC converters

> **Outline Drawing**

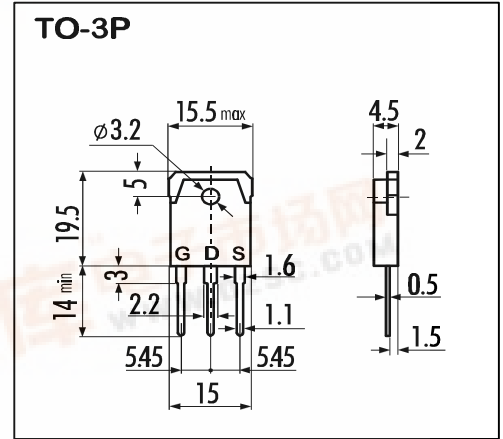

> **Maximum Ratings and Characteristics**

- Absolute Maximum Ratings (T_C=25°C), unless otherwise specified

Item	Symbol	Rating	Unit
Drain-Source-Voltage	V _{DS}	60	V
Continuous Drain Current	I _D	±100	A
Pulsed Drain Current	I _{D(puls)}	±400	A
Gate-Source-Voltage	V _{GS}	+30 /-20	V
Maximum Avalanche Energy	E _{AV}	490.4	mJ*
Max. Power Dissipation	P _D	155	W
Operating and Storage Temperature Range	T _{ch}	150	°C
	T _{stg}	-55 ~ +150	°C

* L=0,65.4uH, V_{CC}=24V

> **Equivalent Circuit**

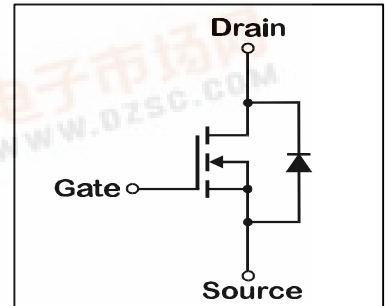

- Electrical Characteristics (T_C=25°C), unless otherwise specified

Item	Symbol	Test conditions	Min.	Typ.	Max.	Unit
Drain-Source Breakdown-Voltage	BV _{DSS}	I _D =1mA V _{GS} =0V	60			V
Gate Threshold Voltage	V _{GS(th)}	I _D =10mA V _{DS} =V _{GS}	2,5	3,0	3,5	V
Zero Gate Voltage Drain Current	I _{DSS}	V _{DS} =60V T _{ch} =25°C		1,0	100,0	μA
		V _{GS} =0V T _{ch} =125°C		10,0	500,0	μA
Gate Source Leakage Current	I _{GSS}	V _{GS} =±30V V _{DS} =0V		10	100	nA
Drain Source On-State Resistance	R _{DS(on)}	I _D =40A V _{GS} =40V		5,0	6,5	mΩ
Forward Transconductance	g _{fs}	I _D =40A V _{DS} =10V	25	50		S
Input Capacitance	C _{iss}	V _{DS} =25V		9000		pF
Output Capacitance	C _{oss}	V _{GS} =0V		1250		pF
Reverse Transfer Capacitance	C _{rss}	f=1MHz		700		pF
Turn-On-Time t _{on} (t _{on} =t _{d(on)} +t _r)	t _{d(on)}	V _{CC} =30V		50		ns
		V _{GS} =10V		200		ns
	t _r	I _D =80A		150		ns
Turn-Off-Time t _{off} (t _{off} =t _{d(off)} +t _f)	t _{d(off)}	R _{GS} =10 Ω		135		ns
	t _f					
Avalanche Capability	I _{AV}	L = 100μH T _{ch} =25°C	100			A
Diode Forward On-Voltage	V _{SD}	I _F =80A V _{GS} =0V T _{ch} =25°C		1,0	1,5	V
Reverse Recovery Time	t _{rr}	I _F =50A V _{GS} =0V		85		ns
Reverse Recovery Charge	Q _{rr}	-dI _F /dt=100A/μs T _{ch} =25°C		0,25		μC

- Thermal Characteristics

Item	Symbol	Test conditions	Min.	Typ.	Max.	Unit
Thermal Resistance	R _{th(ch-a)}	channel to ambient			35,0	°C/W
	R _{th(ch-c)}	channel to case			0,806	°C/W

N-channel MOS-FET			
60V	6,5mΩ	±80A	135W

2SK3271-01

Trench Gate MOSFET



> Characteristics

