

## 250MHz Differential Twisted-Pair Drivers

The EL5171 and EL5371 are single and triple bandwidth amplifiers with an output in differential form. They are primarily targeted for applications such as driving twisted-pair lines in component video applications. The input signal is single-ended and the outputs are always in differential form.

On the EL5171 and EL5371, two feedback inputs provide the user with the ability to set the gain of each device (stable at minimum gain of one). For a fixed gain of two, please see EL5170 and EL5370.

The output common mode level for each channel is set by the associated  $V_{REF}$  pin, which have a -3dB bandwidth of over 50MHz. Generally, these pins are grounded but can be tied to any voltage reference.

All outputs are short circuit protected to withstand temporary overload condition.

The EL5171 and EL5371 are specified for operation over the full -40°C to +85°C temperature range.

## Ordering Information

PART NUMBER	PACKAGE	TAPE & REEL	PKG. DWG. #
EL5171IS	8-Pin SO	-	MDP0027
EL5171IS-T7	8-Pin SO	7"	MDP0027
EL5171IS-T13	8-Pin SO	13"	MDP0027
EL5171ISZ (See Note)	8-Pin SO (Pb-free)	-	MDP0027
EL5171ISZ-T7 (See Note)	8-Pin SO (Pb-free)	7"	MDP0027
EL5171ISZ-T13 (See Note)	8-Pin SO (Pb-free)	13"	MDP0027
EL5371IU	28-Pin QSOP	-	MDP0040
EL5371IU-T7	28-Pin QSOP	7"	MDP0040
EL5371IU-T13	28-Pin QSOP	13"	MDP0040

NOTE: Intersil Pb-free products employ special Pb-free material sets; molding compounds/die attach materials and 100% matte tin plate termination finish, which are RoHS compliant and compatible with both SnPb and Pb-free soldering operations. Intersil Pb-free products are MSL classified at Pb-free peak reflow temperatures that meet or exceed the Pb-free requirements of IPC/JEDEC J STD-020.

## Features

- Fully differential outputs and feedback
- Input range  $\pm 2.3V$  typ.
- 250MHz 3dB bandwidth
- 800V/ $\mu s$  slew rate
- Low distortion at 5MHz
- Single 5V or dual  $\pm 5V$  supplies
- 90mA maximum output current
- Low power - 8mA per channel
- Pb-Free available (RoHS compliant)

## Applications

- Twisted-pair driver
- Differential line driver
- VGA over twisted-pair
- ADSL/HDSL driver
- Single ended to differential amplification
- Transmission of analog signals in a noisy environment

## Pinouts

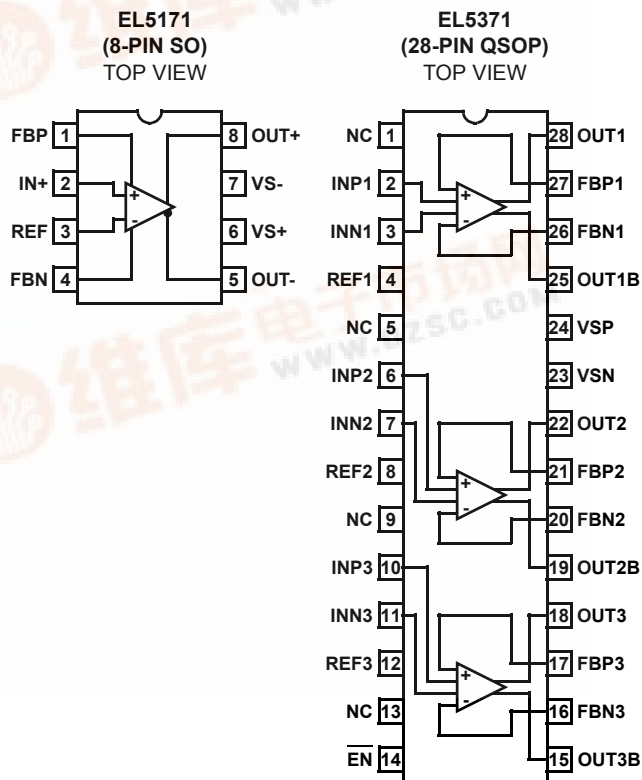

## EL5171, EL5371

### Absolute Maximum Ratings (T<sub>A</sub> = 25°C)

Supply Voltage (V <sub>S+</sub> to V <sub>S-</sub> ) . . . . . 12V	Operating Junction Temperature . . . . . +135°C
Maximum Output Current . . . . . ±60mA	Ambient Operating Temperature . . . . . -40°C to +85°C
Storage Temperature Range . . . . . -65°C to +150°C	

*CAUTION: Stresses above those listed in "Absolute Maximum Ratings" may cause permanent damage to the device. This is a stress only rating and operation of the device at these or any other conditions above those indicated in the operational sections of this specification is not implied.*

*IMPORTANT NOTE: All parameters having Min/Max specifications are guaranteed. Typ values are for information purposes only. Unless otherwise noted, all tests are at the specified temperature and are pulsed tests, therefore: T<sub>J</sub> = T<sub>C</sub> = T<sub>A</sub>*

### Electrical Specifications V<sub>S+</sub> = +5V, V<sub>S-</sub> = -5V, T<sub>A</sub> = 25°C, V<sub>IN</sub> = 0V, R<sub>LD</sub> = 1kΩ, R<sub>F</sub> = 0, R<sub>G</sub> = OPEN, C<sub>LD</sub> = 2.7pF, Unless Otherwise Specified

PARAMETER	DESCRIPTION	CONDITIONS	MIN	TYP	MAX	UNIT
<b>AC PERFORMANCE</b>						
BW	-3dB Bandwidth	A <sub>V</sub> = 1, C <sub>LD</sub> = 2.7pF		250		MHz
		A <sub>V</sub> = 2, R <sub>F</sub> = 500, C <sub>LD</sub> = 2.7pF		60		MHz
		A <sub>V</sub> = 10, R <sub>F</sub> = 500, C <sub>LD</sub> = 2.7pF		10		MHz
BW	±0.1dB Bandwidth	A <sub>V</sub> = 1, C <sub>LD</sub> = 2.7pF		50		MHz
SR	Slew Rate (EL5171)	V <sub>OUT</sub> = 3V <sub>P-P</sub> , 20% to 80%	600	800	1000	V/μs
	Slew Rate (EL5371)	V <sub>OUT</sub> = 3V <sub>P-P</sub> , 20% to 80%	540	700	1000	V/μs
T <sub>STL</sub>	Settling Time to 0.1%	V <sub>OUT</sub> = 2V <sub>P-P</sub>		10		ns
T <sub>OVR</sub>	Output Overdrive Recovery Time			20		ns
GBWP	Gain Bandwidth Product			100		MHz
V <sub>REFBW</sub> (-3dB)	V <sub>REF</sub> -3dB Bandwidth	A <sub>V</sub> = 1, C <sub>LD</sub> = 2.7pF		50		MHz
V <sub>REFSR+</sub>	V <sub>REF</sub> Slew Rate - Rise	V <sub>OUT</sub> = 2V <sub>P-P</sub> , 20% to 80%		90		V/μs
V <sub>REFSR-</sub>	V <sub>REF</sub> Slew Rate - Fall	V <sub>OUT</sub> = 2V <sub>P-P</sub> , 20% to 80%		50		V/μs
V <sub>N</sub>	Input Voltage Noise	at 10kHz		26		nV/√Hz
I <sub>N</sub>	Input Current Noise	at 10kHz		2		pA/√Hz
HD2	Second Harmonic Distortion	V <sub>OUT</sub> = 2V <sub>P-P</sub> , 5MHz		-94		dBc
		V <sub>OUT</sub> = 2V <sub>P-P</sub> , 20MHz		-94		dBc
HD3	Third Harmonic Distortion	V <sub>OUT</sub> = 2V <sub>P-P</sub> , 5MHz		-77		dBc
		V <sub>OUT</sub> = 2V <sub>P-P</sub> , 20MHz		-75		dBc
dG	Differential Gain at 3.58MHz	R <sub>L</sub> = 300Ω, A <sub>V</sub> = 2		0.1		%
dθ	Differential Phase at 3.58MHz	R <sub>L</sub> = 300Ω, A <sub>V</sub> = 2		0.5		°
e <sub>S</sub>	Channel Separation	at f = 1MHz		90		dB
<b>INPUT CHARACTERISTICS</b>						
V <sub>OS</sub>	Input Referred Offset Voltage			±1.5	±25	mV
I <sub>IN</sub>	Input Bias Current (V <sub>IN+</sub> , V <sub>IN-</sub> )		-14	-6	-3	μA
I <sub>REF</sub>	Input Bias Current (V <sub>REF</sub> )		0.5	1.3	4	μA
R <sub>IN</sub>	Differential Input Resistance			300		kΩ
C <sub>IN</sub>	Differential Input Capacitance			1		pF
DMIR	Differential Mode Input Range		±2.1	±2.3	±2.5	V
CMIR+	Common Mode Positive Input Range at V <sub>IN+</sub> , V <sub>IN-</sub>	Tested only for EL5371	3.1	3.4		V
CMIR-	Common Mode Negative Input Range at V <sub>IN+</sub> , V <sub>IN-</sub>	Tested only for EL5371		-4.5	-4.2	V
V <sub>REFIN+</sub>	Positive Reference Input Voltage Range (EL5371)	V <sub>IN+</sub> = V <sub>IN-</sub> = 0V	3.5	±3.8		V

## EL5171, EL5371

**Electrical Specifications**  $V_{S+} = +5V$ ,  $V_{S-} = -5V$ ,  $T_A = 25^\circ C$ ,  $V_{IN} = 0V$ ,  $R_{LD} = 1k\Omega$ ,  $R_F = 0$ ,  $R_G = OPEN$ ,  $C_{LD} = 2.7pF$ , Unless Otherwise Specified **(Continued)**

PARAMETER	DESCRIPTION	CONDITIONS	MIN	TYP	MAX	UNIT
$V_{REFIN-}$	Negative Reference Input Voltage Range (EL5371)	$V_{IN+} = V_{IN-} = 0V$		-3.3	-3	V
$V_{REFOS}$	Output Offset Relative to $V_{REF}$ (EL5371)			$\pm 60$	$\pm 100$	mV
CMRR	Input Common Mode Rejection Ratio (EL5371)	$V_{IN} = \pm 2.5V$	70	82		dB
Gain	Gain Accuracy	$V_{IN} = 1$ (EL5171)	0.981	0.996	1.011	V
		$V_{IN} = 1$ (EL5371)	0.978	0.993	1.008	V
<b>OUTPUT CHARACTERISTICS</b>						
$V_{OUT}$	Output Voltage Swing	$R_L = 500\Omega$ to GND (EL5171)		$\pm 3.4$		V
		$R_L = 500\Omega$ to GND (EL5371)	$\pm 3.6$	$\pm 3.9$		V
$I_{OUT(Max)}$	Maximum Output Current	$R_L = 10\Omega$ , $V_{IN} = \pm 3.24$ (EL5171)	$\pm 70$	$\pm 90$	$\pm 120$	mA
		$R_L = 10\Omega$ , $V_{IN} = \pm 3.24$ (EL5371)	$\pm 50$	$\pm 70$	$\pm 90$	mA
$R_{OUT}$	Output Impedance			130		m $\Omega$
<b>SUPPLY</b>						
$V_{SUPPLY}$	Supply Operating Range	$V_{S+}$ to $V_{S-}$	4.75		11	V
$I_{S(ON)}$	Power Supply Current - Per Channel		6.8	7.5	8.2	mA
$I_{S(OFF)+}$	Positive Power Supply Current - Disabled (EL5371)	$\overline{EN}$ pin tied to 4.8V		1.7	10	$\mu A$
$I_{S(OFF)-}$	Negative Power Supply Current - Disabled (EL5371)		-200	-120		$\mu A$
PSRR	Power Supply Rejection Ratio	$V_S$ from $\pm 4.5V$ to $\pm 5.5V$ (EL5171)	70	84		dB
		$V_S$ from $\pm 4.5V$ to $\pm 5.5V$ (EL5371)	65	83		dB
<b>ENABLE (EL5371 ONLY)</b>						
$t_{EN}$	Enable Time			215		ns
$t_{DS}$	Disable Time			0.95		$\mu s$
$V_{IH}$	$\overline{EN}$ Pin Voltage for Power-Up				$V_{S+} - 1.5$	V
$V_{IL}$	$\overline{EN}$ Pin Voltage for Shut-Down		$V_{S+} - 0.5$			V
$I_{IH-EN}$	$\overline{EN}$ Pin Input Current High	At $V_{EN} = 5V$		122	130	$\mu A$
$I_{IL-EN}$	$\overline{EN}$ Pin Input Current Low	At $V_{EN} = 0V$	-10	-8		$\mu A$

### Pin Descriptions

EL5171	EL5371	PIN NAME	PIN FUNCTION
1	17, 21, 27	FBP1, 2, 3	Feedback from non-inverting output
2	2, 6, 10	INP1, 2, 3	Non-inverting inputs
3	3, 7, 11	INN1, 2, 3	Inverting inputs, note that on EL5171, this pin is also the REF pin
4	16, 20, 26	FBN1, 2, 3	Feedback from inverting output
5	15, 19, 25	OUT1B, 2B, 3B	Inverting outputs
6	24	VSP	Positive supply
7	23	VSN	Negative supply
8	18, 22, 28	OUT1, 2, 3	Non-inverting outputs
	1, 5, 9, 13	NC	No connects, grounded for best crosstalk performance
	4, 8, 12	REF1, 2, 3	Reference input, sets common-mode output voltage
	14	$\overline{EN}$	ENABLE

Connection Diagrams

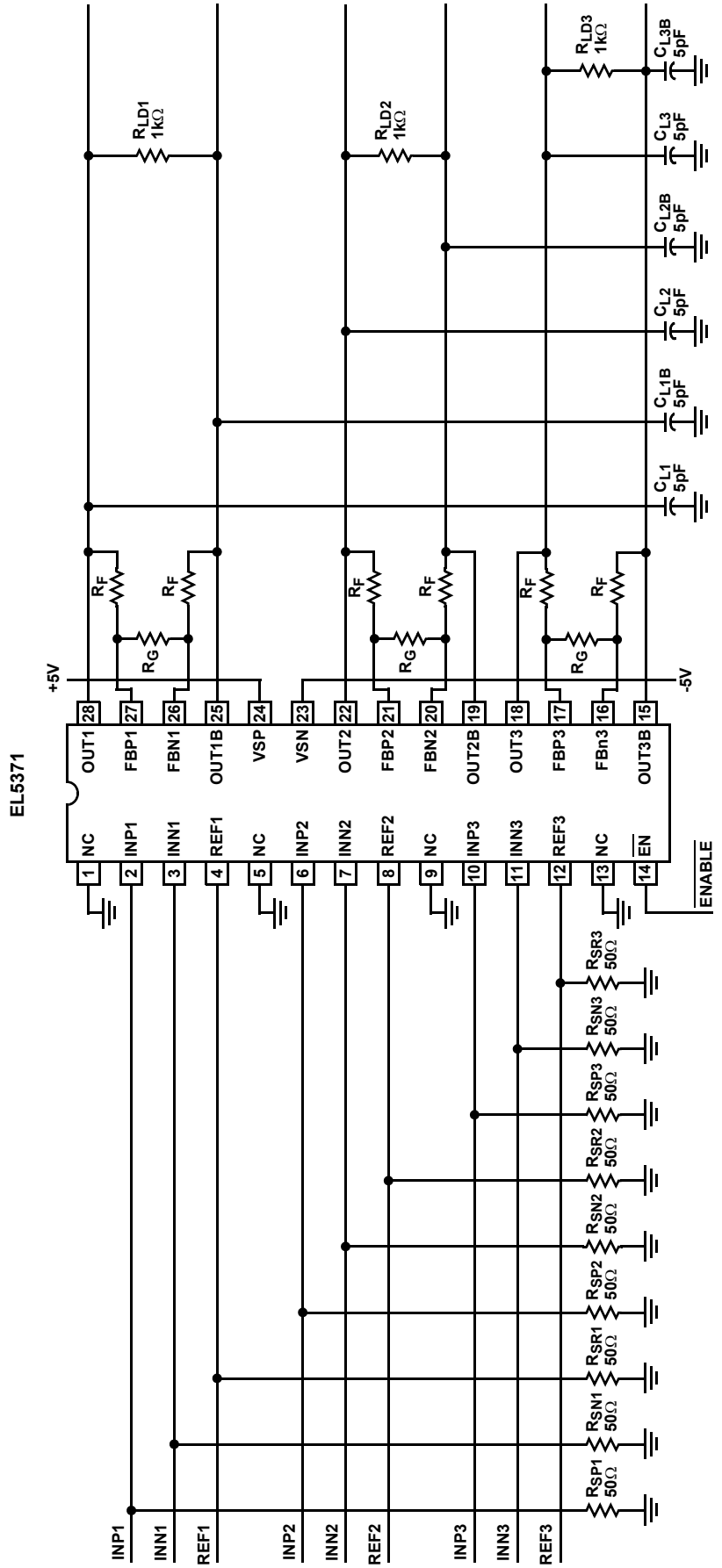
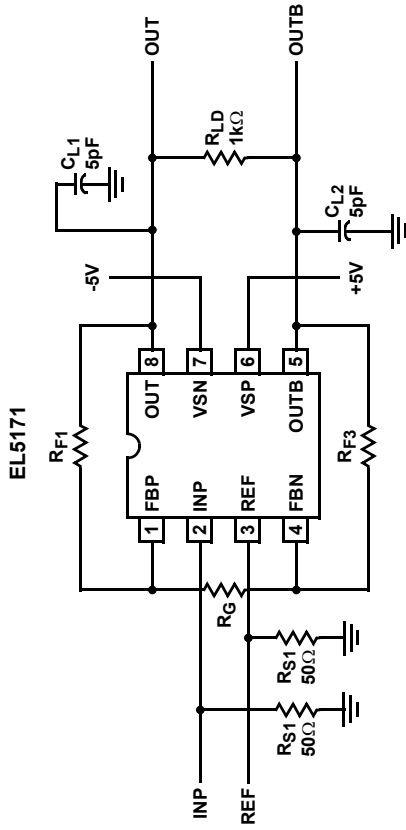

Typical Performance Curves

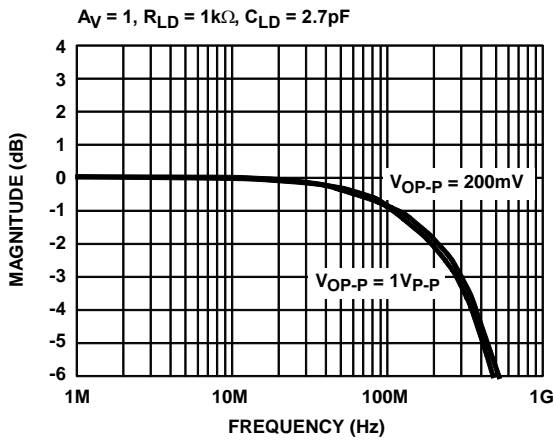

FIGURE 1. FREQUENCY RESPONSE

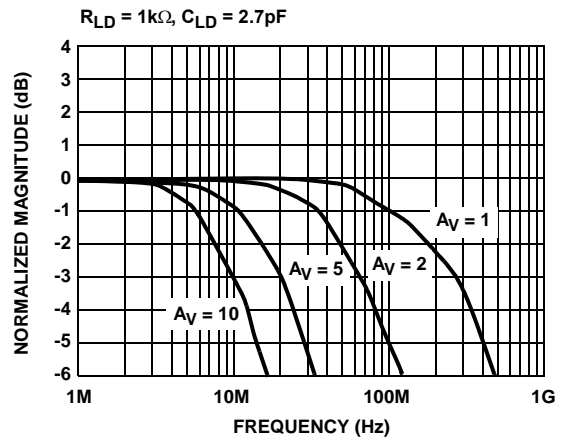

FIGURE 2. FREQUENCY RESPONSE FOR VARIOUS GAIN

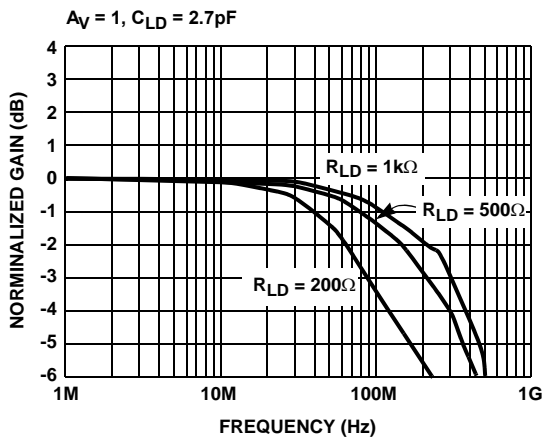

FIGURE 3. FREQUENCY RESPONSE vs  $R_{LD}$

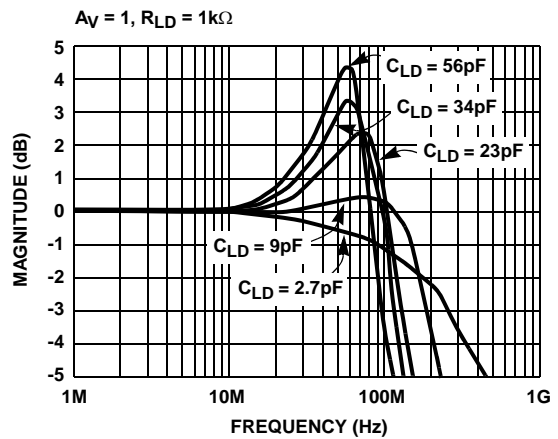

FIGURE 4. FREQUENCY RESPONSE vs  $C_{LD}$

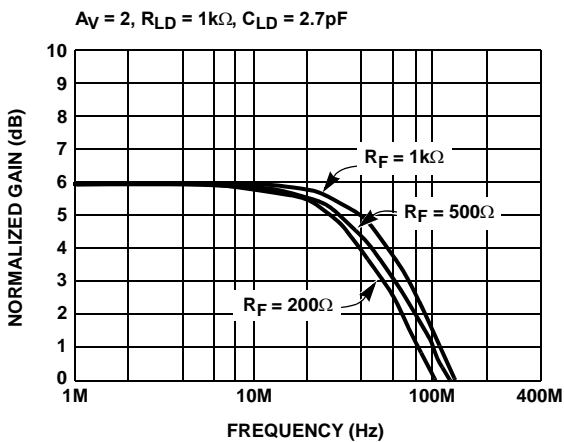

FIGURE 5. FREQUENCY RESPONSE

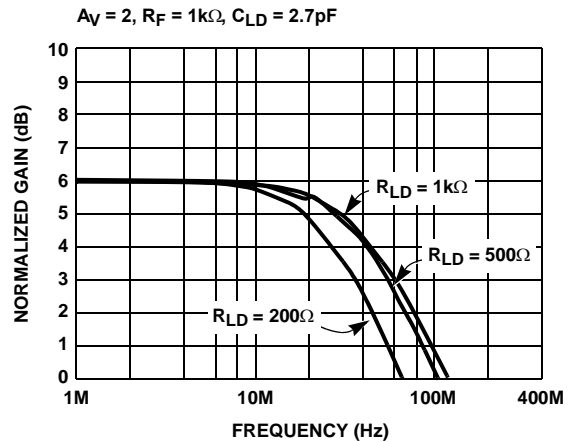

FIGURE 6. FREQUENCY RESPONSE vs  $R_{LD}$

Typical Performance Curves (Continued)

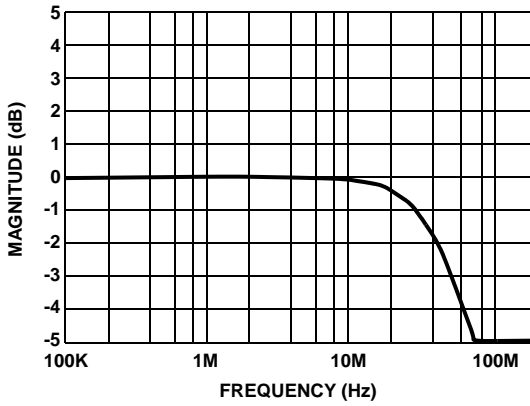

FIGURE 7. FREQUENCY RESPONSE -  $V_{REF}$

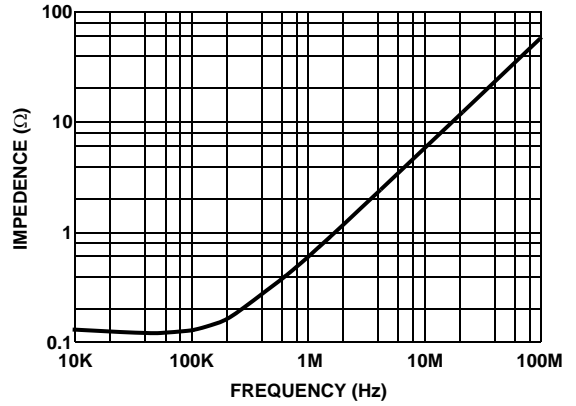

FIGURE 8. OUTPUT IMPEDANCE vs FREQUENCY

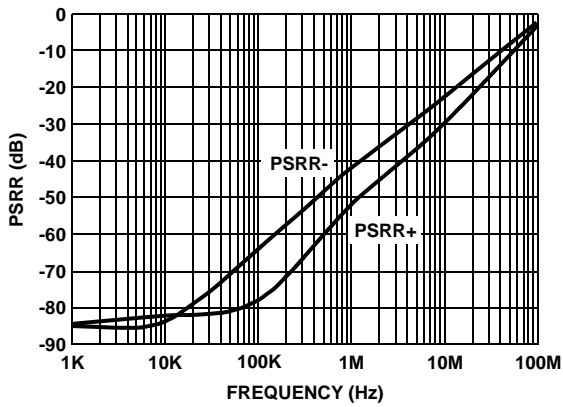

FIGURE 9. PSRR vs FREQUENCY

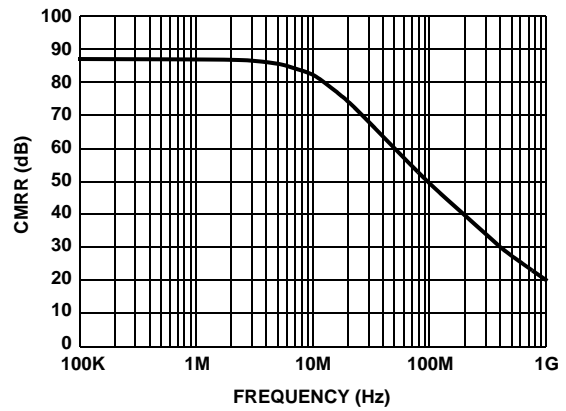

FIGURE 10. CMRR vs FREQUENCY

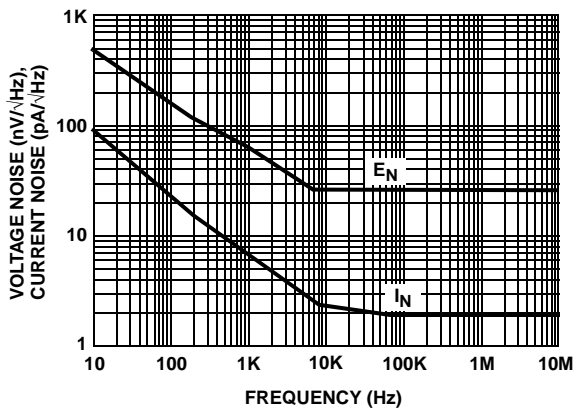

FIGURE 11. VOLTAGE AND CURRENT NOISE vs FREQUENCY

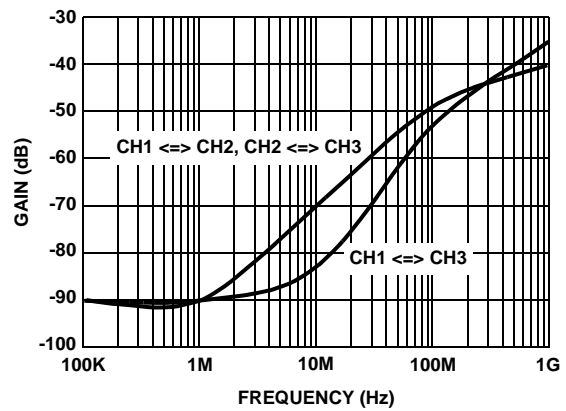

FIGURE 12. CHANNEL ISOLATION vs FREQUENCY

Typical Performance Curves (Continued)

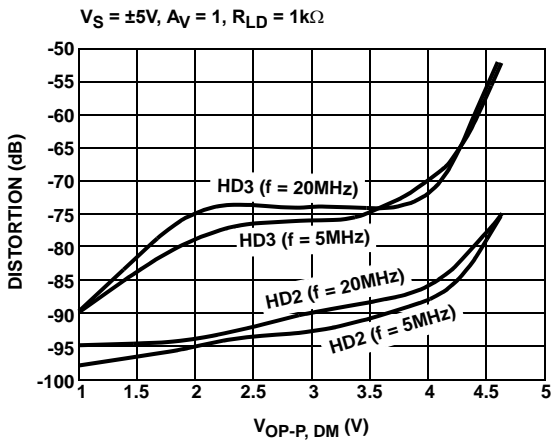

FIGURE 13. HARMONIC DISTORTION vs DIFFERENTIAL OUTPUT VOLTAGE

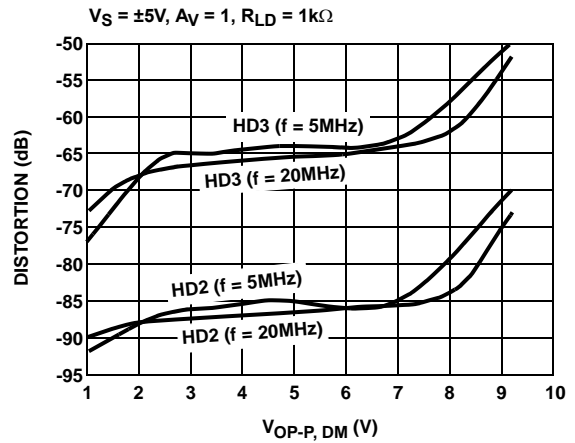

FIGURE 14. HARMONIC DISTORTION vs DIFFERENTIAL OUTPUT VOLTAGE

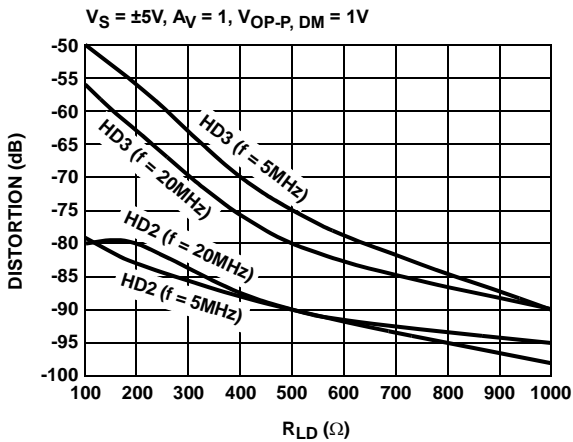

FIGURE 15. HARMONIC DISTORTION vs  $R_{LD}$

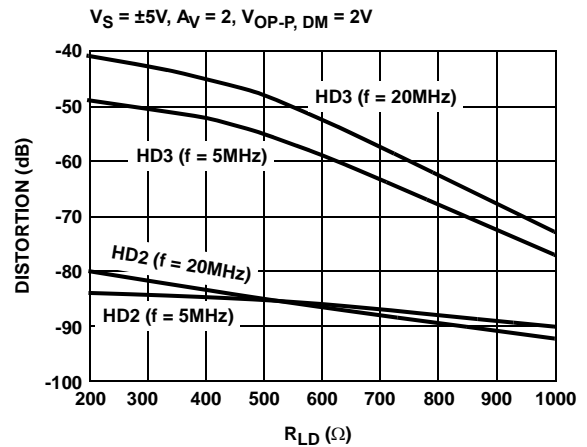

FIGURE 16. HARMONIC DISTORTION vs  $R_{LD}$

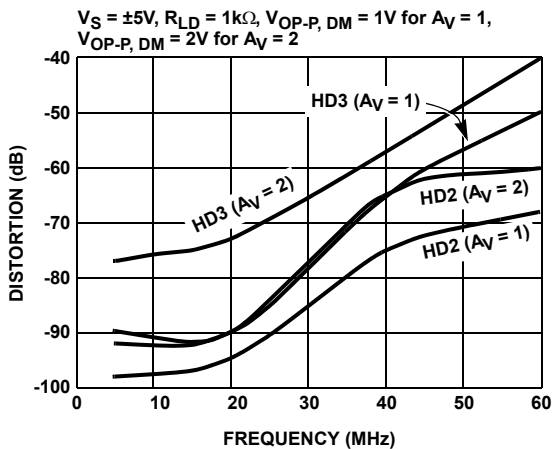

FIGURE 17. HARMONIC DISTORTION vs FREQUENCY

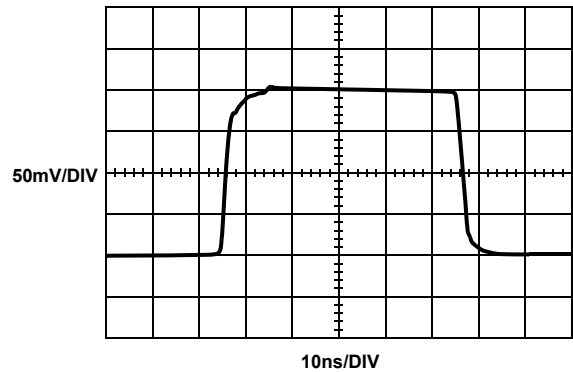

FIGURE 18. SMALL SIGNAL TRANSIENT RESPONSE

Typical Performance Curves (Continued)

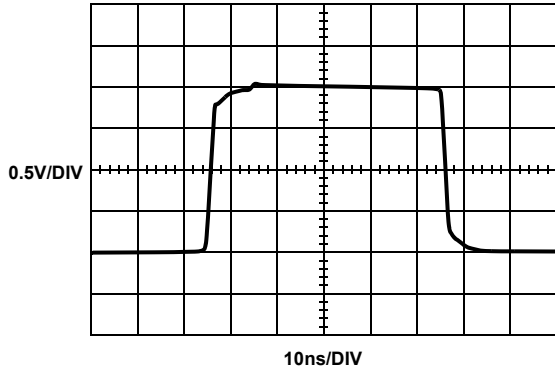

FIGURE 19. LARGE SIGNAL TRANSIENT RESPONSE

M = 100ns, CH1 = 500mV/DIV, CH2 = 5V/DIV

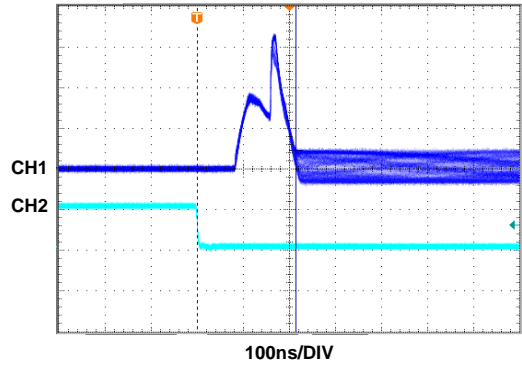

FIGURE 20. ENABLED RESPONSE

M = 200ns, CH1 = 500mV/DIV, CH2 = 5V/DIV

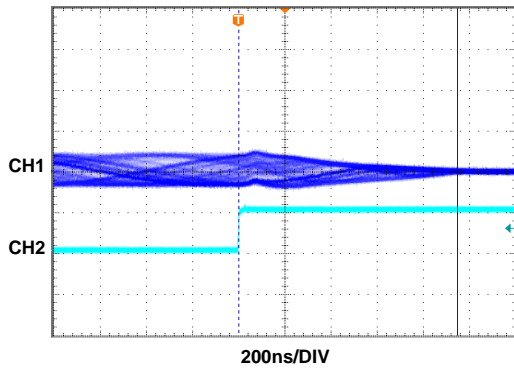

FIGURE 21. DISABLED RESPONSE

JEDEC JESD51-3 LOW EFFECTIVE THERMAL CONDUCTIVITY TEST BOARD

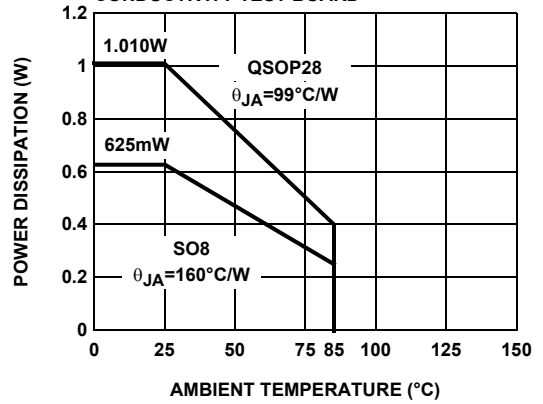

FIGURE 22. PACKAGE POWER DISSIPATION vs AMBIENT TEMPERATURE

JEDEC JESD51-7 HIGH EFFECTIVE THERMAL CONDUCTIVITY TEST BOARD

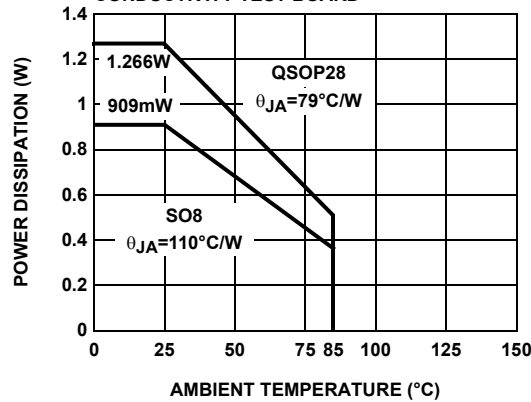
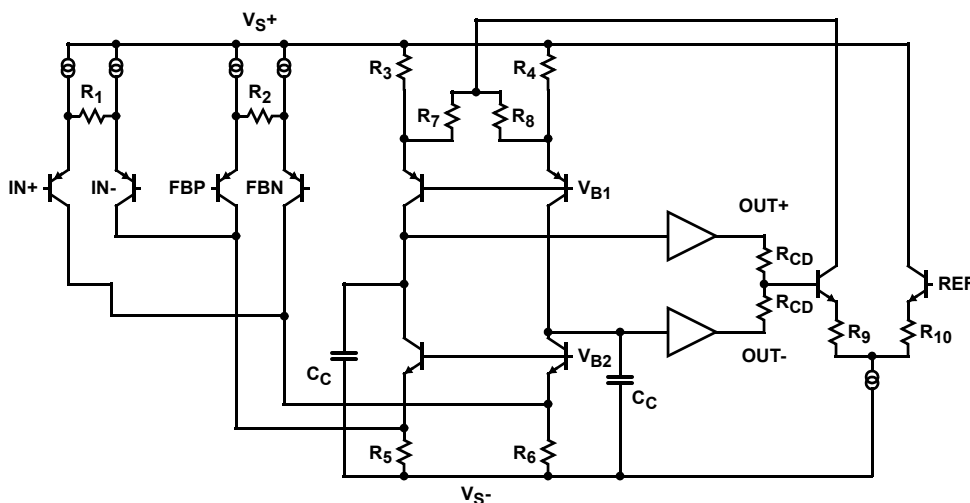

FIGURE 23. PACKAGE POWER DISSIPATION vs AMBIENT TEMPERATURE



## Simplified Schematic



## Description of Operation and Application Information

### Product Description

The EL5171 and EL5371 are wide bandwidth, low power and single ended to differential output amplifiers. The EL5171 is a single channel differential amplifier. Since the  $I_{N-}$  pin and REF pin are tied together internally, the EL5171 can be used as a single ended to differential converter. The EL5371 is a triple channel differential amplifier. The EL5371 have a separate  $I_{N-}$  pin and REF pin for each channel. It can be used as single/differential ended to differential converter. The EL5171 and EL5371 are internally compensated for closed loop gain of +1 or greater. Connected in gain of 1 and driving a  $1\text{k}\Omega$  differential load, the EL5171 and EL5371 have a -3dB bandwidth of 250MHz. Driving a  $200\Omega$  differential load at gain of 2, the bandwidth is about 30MHz. The EL5371 is available with a power down feature to reduce the power while the amplifier is disabled.

### Input, Output, and Supply Voltage Range

The EL5171 and EL5371 have been designed to operate with a single supply voltage of 5V to 10V or a split supplies with its total voltage from 5V to 10V. The amplifiers have an input common mode voltage range from -4.5V to 3.4V for  $\pm 5\text{V}$  supply. The differential mode input range (DMIR) between the two inputs is from -2.3V to +2.3V. The input voltage range at the REF pin is from -3.3V to 3.8V. If the input common mode or differential mode signal is outside the above-specified ranges, it will cause the output signal distorted.

The output of the EL5171 and EL5371 can swing from -3.9V to +3.9V at  $1\text{k}\Omega$  differential load at  $\pm 5\text{V}$  supply. As the load resistance becomes lower, the output swing is reduced.

### Differential and Common Mode Gain Settings

For EL5171, since the  $I_{N-}$  pin and REF pin are bounded together as the REF pin in an 8-pin package, the signal at the REF pin is part of the common mode signal and also part of the differential mode signal. For the true balance differential outputs, the REF pin must be tied to the same bias level as the  $I_{N+}$  pin. For a  $\pm 5\text{V}$  supply, just tie the REF pin to GND if the  $I_{N+}$  pin is biased at 0V with a  $50\Omega$  or  $75\Omega$  termination resistor. For a single supply application, if the  $I_{N+}$  is biased to half of the rail, the REF pin should be biased to half of the rail also.

The gain setting for EL5171 is:

$$V_{ODM} = V_{IN+} \times \left( 1 + \frac{R_{F1} + R_{F2}}{R_G} \right)$$

$$V_{ODM} = V_{IN+} \times \left( 1 + \frac{2R_F}{R_G} \right)$$

$$V_{OCM} = V_{REF} = 0\text{V}$$

Where:

- $V_{REF} = 0\text{V}$
- $R_{F1} = R_{F2} = R_F$

EL5371 has a separate  $I_{N-}$  pin and REF pin. It can be used as a single/differential ended to differential converter. The voltage applied at REF pin can set the output common mode voltage and the gain is one.

## EL5171, EL5371

The gain setting for EL5371 is:

$$V_{ODM} = (V_{IN+} - V_{IN-}) \times \left( 1 + \frac{R_{F1} + R_{F2}}{R_G} \right)$$

$$V_{ODM} = (V_{IN+} - V_{IN-}) \times \left( 1 + \frac{2R_F}{R_G} \right)$$

$$V_{OCM} = V_{REF}$$

Where:

- $R_{F1} = R_{F2} = R_F$

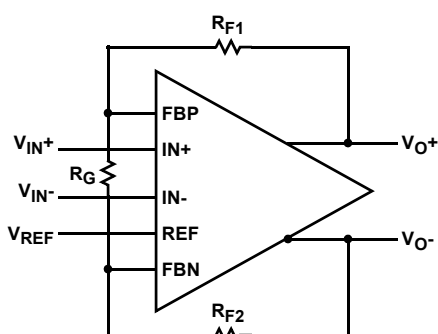

FIGURE 24.

### Choice of Feedback Resistor and Gain Bandwidth Product

For applications that require a gain of +1, no feedback resistor is required. Just short the OUT+ pin to FBP pin and OUT- pin to FBN pin. For gains greater than +1, the feedback resistor forms a pole with the parasitic capacitance at the inverting input. As this pole becomes smaller, the amplifier's phase margin is reduced. This causes ringing in the time domain and peaking in the frequency domain. Therefore,  $R_F$  has some maximum value that should not be exceeded for optimum performance. If a large value of  $R_F$  must be used, a small capacitor in the few Pico farad range in parallel with  $R_F$  can help to reduce the ringing and peaking at the expense of reducing the bandwidth.

The bandwidth of the EL5171 and EL5371 depends on the load and the feedback network.  $R_F$  and  $R_G$  appear in parallel with the load for gains other than +1. As this combination gets smaller, the bandwidth falls off. Consequently,  $R_F$  also has a minimum value that should not be exceeded for optimum bandwidth performance. For gain of +1,  $R_F = 0$  is optimum. For the gains other than +1, optimum response is obtained with  $R_F$  between 500Ω to 1kΩ.

The EL5171 and EL5371 have a gain bandwidth product of 100MHz for  $R_{LD} = 1k\Omega$ . For gains  $\geq 5$ , its bandwidth can be predicted by the following equation:

$$\text{Gain} \times \text{BW} = 100\text{MHz}$$

### Driving Capacitive Loads and Cables

The EL5171 and EL5371 can drive 50pF differential capacitor in parallel with 1kΩ differential load with less than 5dB of peaking at gain of +1. If less peaking is desired in applications, a small series resistor (usually between 5Ω to 50Ω) can be placed in series with each output to eliminate most peaking. However, this will reduce the gain slightly. If the gain setting is greater than 1, the gain resistor  $R_G$  can then be chosen to make up for any gain loss which may be created by the additional series resistor at the output.

When used as a cable driver, double termination is always recommended for reflection-free performance. For those applications, a back-termination series resistor at the amplifier's output will isolate the amplifier from the cable and allow extensive capacitive drive. However, other applications may have high capacitive loads without a back-termination resistor. Again, a small series resistor at the output can help to reduce peaking.

### Disable/Power-Down (for EL5371 only)

The EL5371 can be disabled and placed its outputs in a high impedance state. The turn off time is about 0.95μs and the turn on time is about 215ns. When disabled, the amplifier's supply current is reduced to 1.7μA for  $I_{S+}$  and 120μA for  $I_{S-}$  typically, thereby effectively eliminating the power consumption. The amplifier's power down can be controlled by standard CMOS signal levels at the ENABLE pin. The applied logic signal is relative to  $V_{S+}$  pin. Letting the  $\overline{EN}$  pin float or applying a signal that is less than 1.5V below  $V_{S+}$  will enable the amplifier. The amplifier will be disabled when the signal at  $\overline{EN}$  pin is above  $V_{S+} - 0.5V$ .

### Output Drive Capability

The EL5171 and EL5371 have internal short circuit protection. Its typical short circuit current is ±90mA for EL5171 and ±70mA for EL5371. If the output is shorted indefinitely, the power dissipation could easily increase such that the part will be destroyed. Maximum reliability is maintained if the output current never exceeds ±60mA. This limit is set by the design of the internal metal interconnections.

### Power Dissipation

With the high output drive capability of the EL5171 and EL5371. It is possible to exceed the 135°C absolute maximum junction temperature under certain load current conditions. Therefore, it is important to calculate the maximum junction temperature for the application to determine if the load conditions or package types need to be modified for the amplifier to remain in the safe operating area.

## EL5171, EL5371

The maximum power dissipation allowed in a package is determined according to:

$$PD_{MAX} = \frac{T_{JMAX} - T_{AMAX}}{\Theta_{JA}}$$

Where:

- $T_{JMAX}$  = Maximum junction temperature
- $T_{AMAX}$  = Maximum ambient temperature
- $\Theta_{JA}$  = Thermal resistance of the package

The maximum power dissipation actually produced by an IC is the total quiescent supply current times the total power supply voltage, plus the power in the IC due to the load, or:

$$PD = i \times \left( V_S \times I_{SMAX} + V_S \times \frac{\Delta V_O}{R_{LD}} \right)$$

Where:

- $V_S$  = Total supply voltage
- $I_{SMAX}$  = Maximum quiescent supply current per channel
- $\Delta V_O$  = Maximum differential output voltage of the application
- $R_{LD}$  = Differential load resistance
- $I_{LOAD}$  = Load current
- $i$  = Number of channels

### Typical Applications

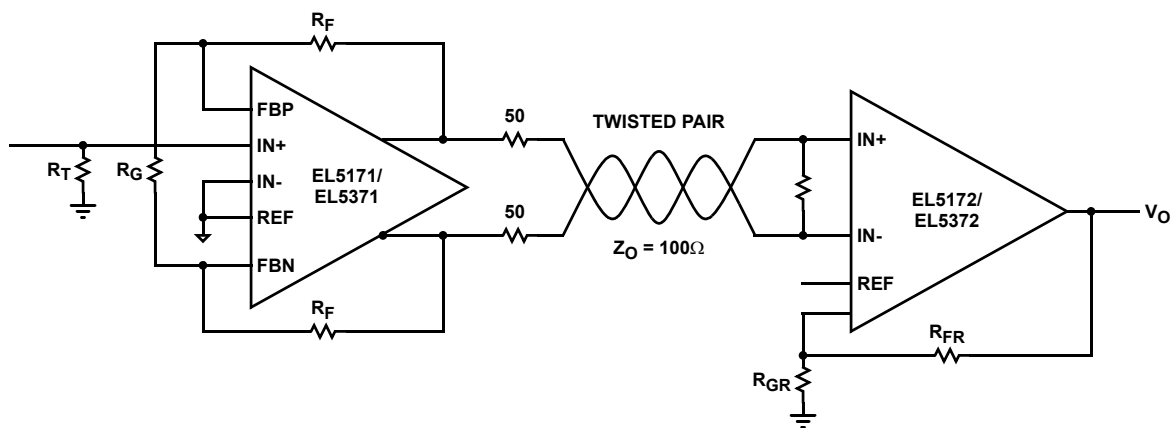

FIGURE 25. TWISTED PAIR CABLE RECEIVER

By setting the two  $PD_{MAX}$  equations equal to each other, we can solve the output current and  $R_{LD}$  to avoid the device overheat.

### Power Supply Bypassing and Printed Circuit Board Layout

As with any high frequency device, a good printed circuit board layout is necessary for optimum performance. Lead lengths should be as short as possible. The power supply pin must be well bypassed to reduce the risk of oscillation. For normal single supply operation, where the  $V_{S-}$  pin is connected to the ground plane, a single 4.7 $\mu$ F tantalum capacitor in parallel with a 0.1 $\mu$ F ceramic capacitor from  $V_{S+}$  to GND will suffice. This same capacitor combination should be placed at each supply pin to ground if split supplies are to be used. In this case, the  $V_{S-}$  pin becomes the negative supply rail.

For good AC performance, parasitic capacitance should be kept to minimum. Use of wire wound resistors should be avoided because of their additional series inductance. Use of sockets should also be avoided if possible. Sockets add parasitic inductance and capacitance that can result in compromised performance. Minimizing parasitic capacitance at the amplifier's inverting input pin is very important. The feedback resistor should be placed very close to the inverting input pin. Strip line design techniques are recommended for the signal traces.

## EL5171, EL5371

As the signal is transmitted through a cable, the high frequency signal will be attenuated. One way to compensate

this loss is to boost the high frequency gain at the receiver side.

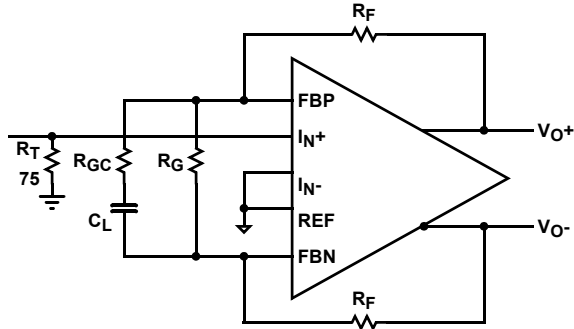

$$\text{DC Gain} = 1 + \frac{2R_F}{R_G}$$

$$\text{(HF)Gain} = 1 + \frac{2R_F}{R_G \parallel R_{GC}}$$

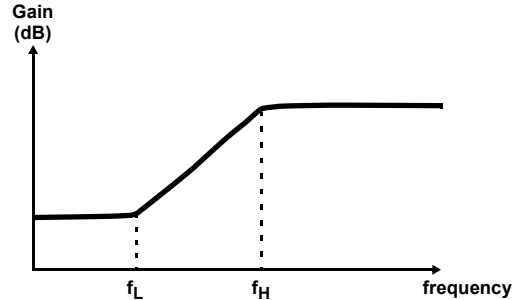

$$f_L \cong \frac{1}{2\pi R_G C_C}$$

$$f_H \cong \frac{1}{2\pi R_{GC} C_C}$$

FIGURE 26. TRANSMIT EQUALIZER

### SO Package Outline Drawing

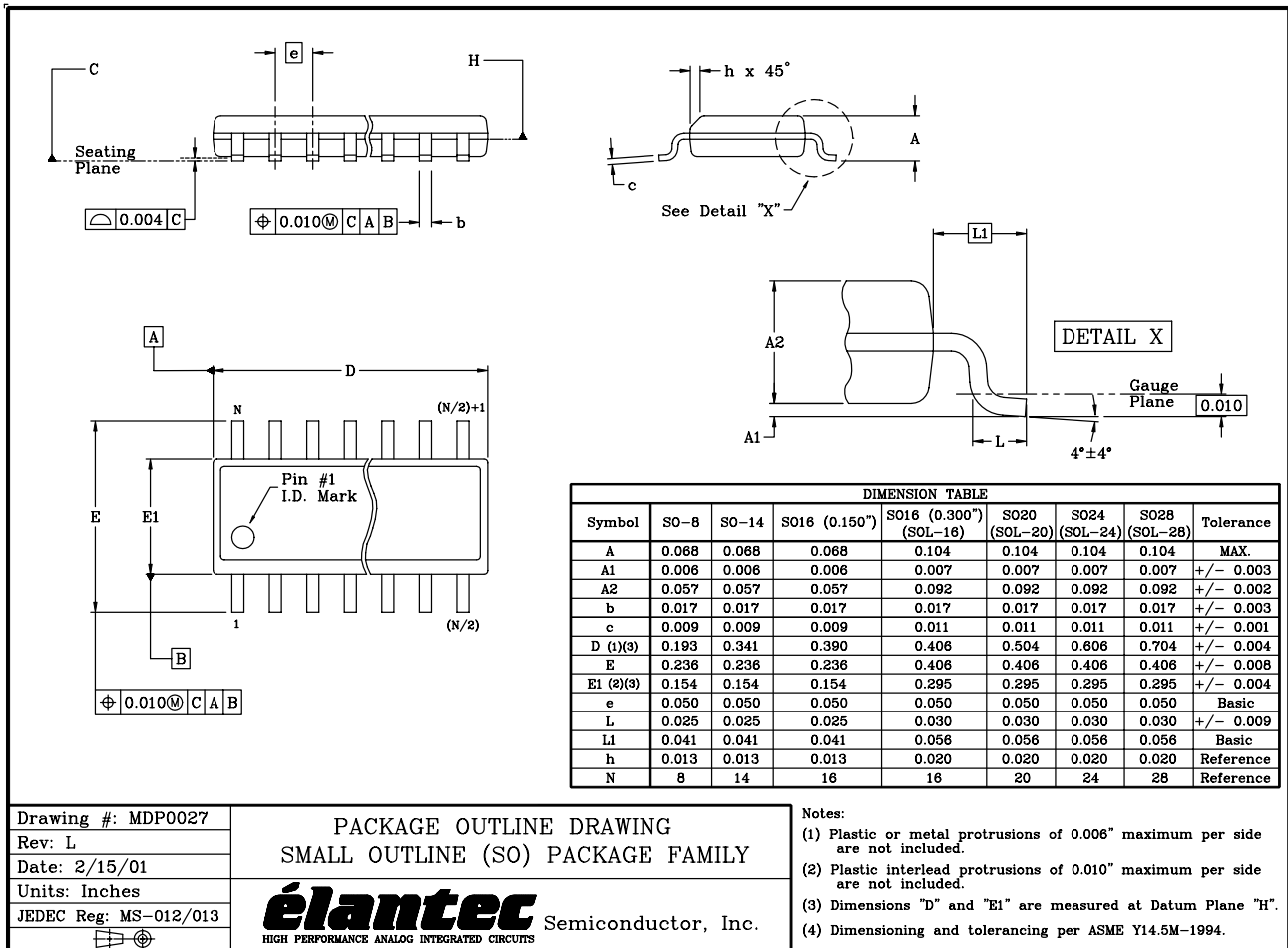

# EL5171, EL5371

## QSOP Package Outline Drawing

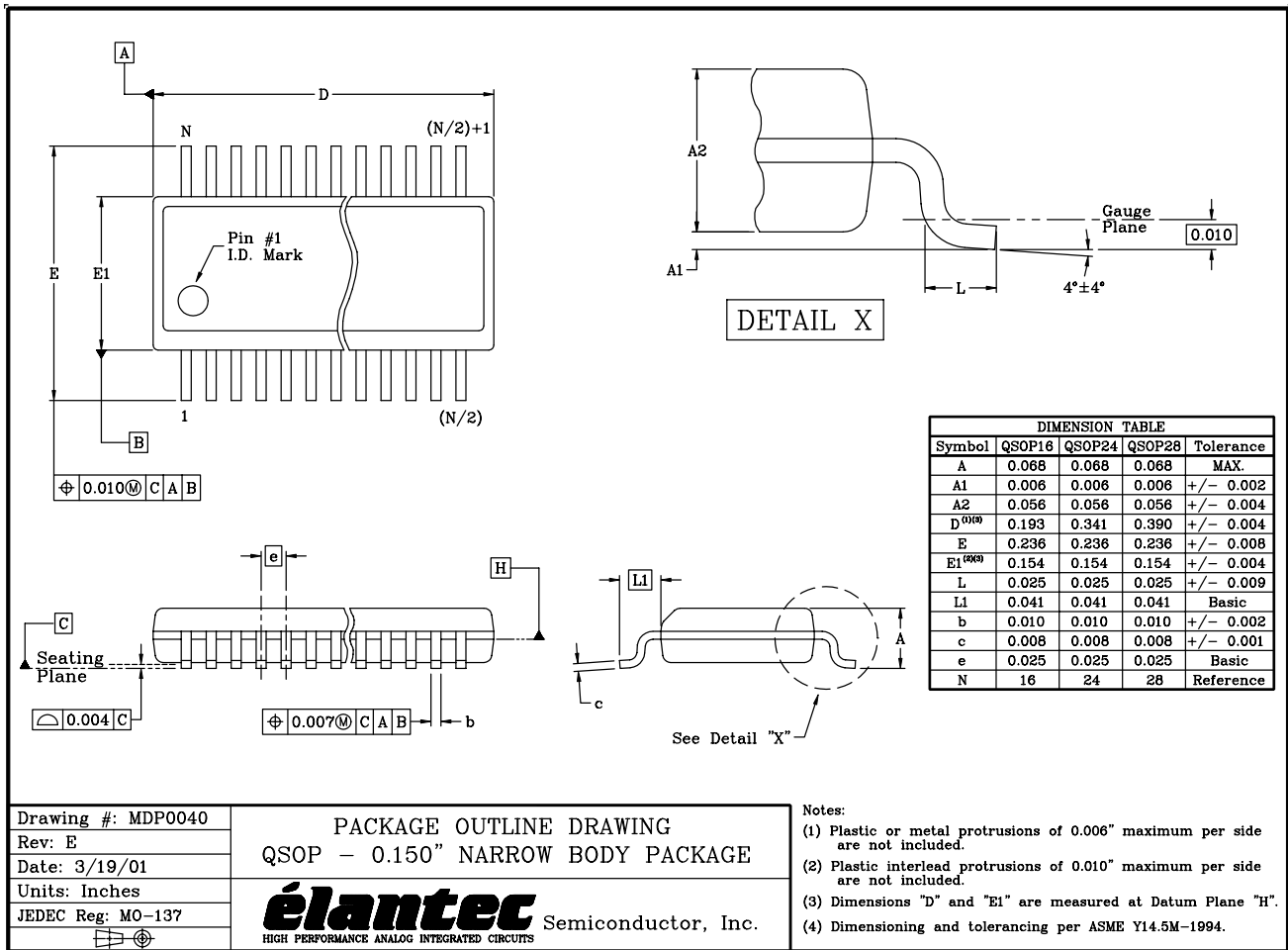

NOTE: The package drawing shown here may not be the latest version. To check the latest revision, please refer to the Intersil website at <http://www.intersil.com/design/packages/index.asp>

All Intersil U.S. products are manufactured, assembled and tested utilizing ISO9000 quality systems. Intersil Corporation's quality certifications can be viewed at [www.intersil.com/design/quality](http://www.intersil.com/design/quality)

Intersil products are sold by description only. Intersil Corporation reserves the right to make changes in circuit design, software and/or specifications at any time without notice. Accordingly, the reader is cautioned to verify that data sheets are current before placing orders. Information furnished by Intersil is believed to be accurate and reliable. However, no responsibility is assumed by Intersil or its subsidiaries for its use; nor for any infringements of patents or other rights of third parties which may result from its use. No license is granted by implication or otherwise under any patent or patent rights of Intersil or its subsidiaries.

For information regarding Intersil Corporation and its products, see [www.intersil.com](http://www.intersil.com)