

> **Features**

- High Speed Switching
- Low On-Resistance
- No Secondary Breakdown
- Low Driving Power
- High Voltage
- VGS = ± 30V Guarantee
- Avalanche Proof

> **Applications**

- Switching Regulators
- UPS
- DC-DC converters
- General Purpose Power Amplifier

> **Outline Drawing**

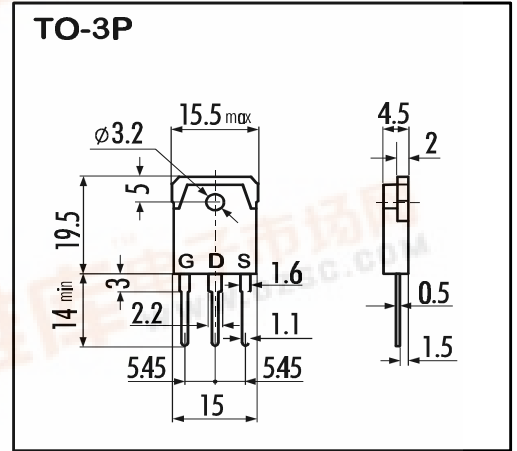

> **Maximum Ratings and Characteristics**

- Absolute Maximum Ratings (TC=25°C), unless otherwise specified

| Item | Symbol | Rating | Unit |
|-----------------------------------------|----------------------|------------|------|
| Drain-Source-Voltage | V _{DS} | 300 | V |
| Drain-Gate-Voltage | V _{DGR} | 300 | V |
| Continous Drain Current | I _D | 20 | A |
| Pulsed Drain Current | I _{D(puls)} | 80 | A |
| Gate-Source-Voltage | V _{GS} | 30 | V |
| Max. Power Dissipation | P _D | 125 | W |
| Operating and Storage Temperature Range | T _{ch} | 150 | °C |
| | T _{stg} | -55 ~ +150 | °C |

> **Equivalent Circuit**

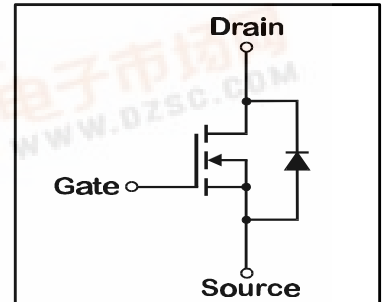

- Electrical Characteristics (TC=25°C), unless otherwise specified

| Item | Symbol | Test conditions | Min. | Typ. | Max. | Unit |
|-----------------------------------------------------------------------------------------|----------------------|----------------------------------------------------------------------------|------|------|------|------|
| Drain-Source Breakdown-Voltage | V _{(BR)DSS} | I _D =1mA V _{GS} =0V | 300 | | | V |
| Gate Threshold Voltage | V _{GS(th)} | I _D =1mA V _{DS} =V _{GS} | 3,5 | 4,0 | 4,5 | V |
| Zero Gate Voltage Drain Current | I _{DSS} | V _{DS} =300V T _{ch} =25°C | | 10 | 500 | μA |
| | | V _{DS} =0V T _{ch} =125°C | | 0,2 | 1,0 | mA |
| Gate Source Leakage Current | I _{GSS} | V _{GS} =±30V V _{DS} =0V | | 10 | 100 | nA |
| Drain Source On-State Resistance | R _{DS(on)} | I _D =10A V _{GS} =10V | | 0,13 | 0,2 | Ω |
| Forward Transconductance | g _{fs} | I _D =10A V _{DS} =25V | 5 | 10 | | S |
| Input Capacitance | C _{iss} | V _{DS} =25V | | 1900 | 2850 | pF |
| Output Capacitance | C _{oss} | V _{GS} =0V | | 400 | 600 | pF |
| Reverse Transfer Capacitance | C _{rss} | f=1MHz | | 180 | 270 | pF |
| Turn-On-Time t _{on} (t _{on} =t _{d(on)} +t _r) | t _{d(on)} | V _{CC} =150V | | 20 | 30 | ns |
| | | I _D =20A | | 80 | 120 | ns |
| Turn-Off-Time t _{off} (t _{off} =t _{d(off)} +t _f) | t _{d(off)} | V _{GS} =10V | | 100 | 150 | ns |
| | | R _{GS} =10 Ω | | 50 | 75 | ns |
| Avalanche Capability | I _{AV} | L = 100μH T _{ch} =25°C | 20 | | | A |
| Diode Forward On-Voltage | V _{SD} | I _F =2I _{DR} V _{GS} =0V T _{ch} =25°C | | 1,3 | 1,9 | V |
| Reverse Recovery Time | t _{rr} | I _F =I _{DR} V _{GS} =0V | | 300 | | ns |
| Reverse Recovery Charge | Q _{rr} | -dI _F /dt=100A/μs T _{ch} =25°C | | 4,0 | | μC |

- Thermal Characteristics

| Item | Symbol | Test conditions | Min. | Typ. | Max. | Unit |
|--------------------|-----------------------|-----------------|------|------|------|------|
| Thermal Resistance | R _{th(ch-a)} | channel to air | | | 35 | °C/W |
| | R _{th(ch-c)} | channel to case | | | 1,0 | °C/W |

| | | | |
|-------------------|------|-----|------|
| N-channel MOS-FET | | | |
| 300V | 0,2Ω | 20A | 125W |

2SK2473-01

FAP-II Series



> Characteristics

Typical Output Characteristics
 $I_D = f(V_{DS})$; 80μs pulse test; $T_C = 25^\circ\text{C}$

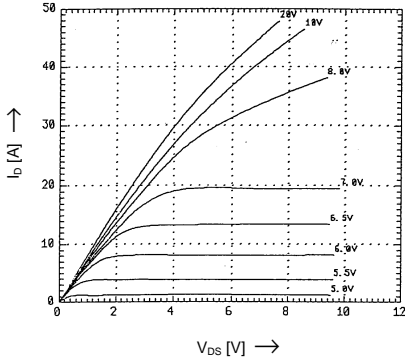

Drain-Source On-State Resistance vs. T_{ch}
 $R_{DS(on)} = f(T_{ch})$; $I_D = 10\text{A}$; $V_{GS} = 10\text{V}$

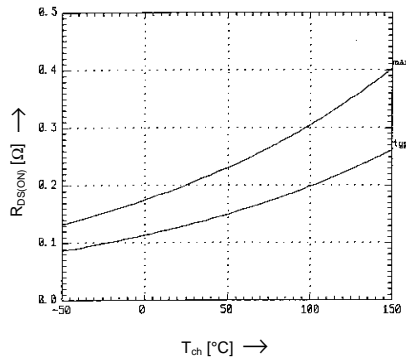

Typical Transfer Characteristics
 $I_D = f(V_{GS})$; 80μs pulse test; $V_{DS} = 25\text{V}$; $T_{ch} = 25^\circ\text{C}$

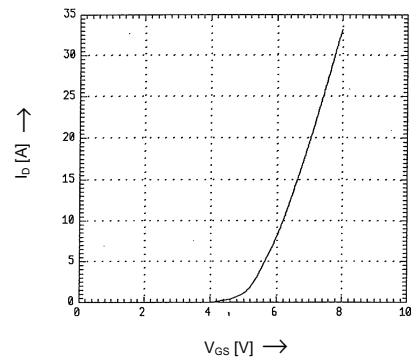

Typical Drain-Source On-State-Resistance
 $R_{DS(on)} = f(I_D)$; 80μs pulse test; $T_C = 25^\circ\text{C}$

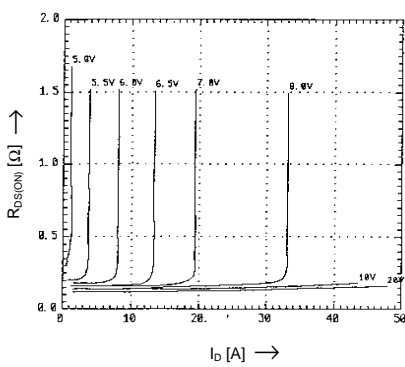

Typical Transconductance
 $g_{fs} = f(I_D)$; 80μs pulse test; $V_{DS} = 25\text{V}$; $T_{ch} = 25^\circ\text{C}$

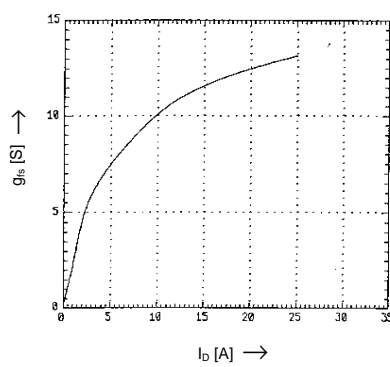

Gate Threshold Voltage
 $V_{GS(th)} = f(T_{ch})$; $I_D = 1\text{mA}$; $V_{DS} = V_{GS}$

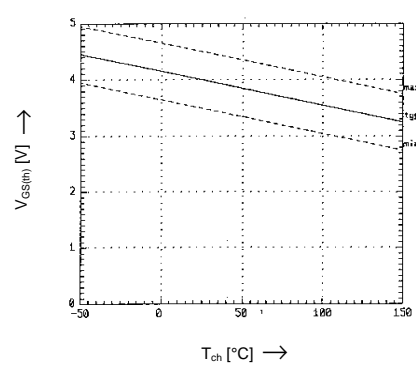

Typical Capacitances
 $C = f(V_{DS})$; $V_{GS} = 0\text{V}$; $f = 1\text{MHz}$

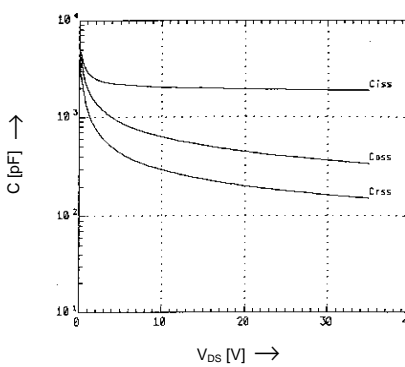

Typical Gate Charge Characteristics
 $V_{GS} = f(Q_g)$; $I_D = 20\text{A}$

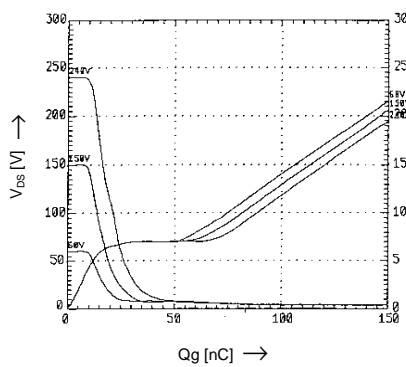

Forward Characteristics of Reverse Diode
 $I_F = f(V_{SD})$; 80μs pulse test

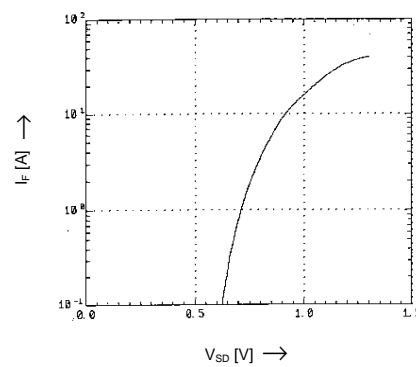

Power Dissipation
 $P_D = f(T_C)$

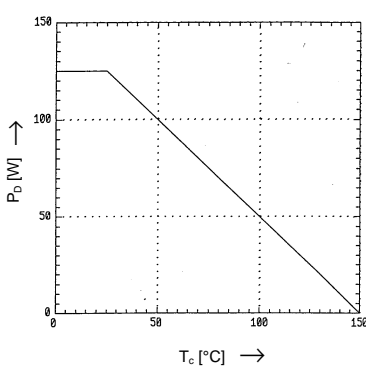

Safe Operation Area
 $I_D = f(V_{DS})$; $D = 0,01$; $T_C = 25^\circ\text{C}$

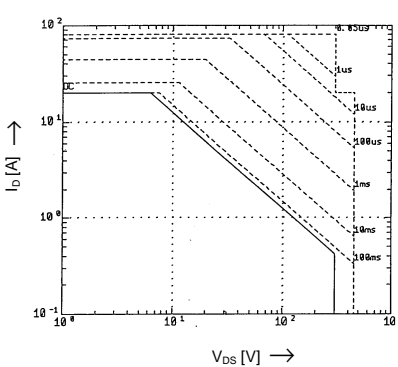

$Z_{th(ch-c)}$ [K/W]

Transient Thermal Impedance
 $Z_{th(ch-c)} = f(t)$ parameter: $D = t/T$

