

**FAIRCHILD**  
SEMICONDUCTOR™

August 1986  
Revised March 2000

## DM74123 Dual Retriggerable One-Shot with Clear and Complementary Outputs

### General Description

The DM74123 is a dual retriggerable monostable multivibrator capable of generating output pulses from a few nano-seconds to extremely long duration up to 100% duty cycle. Each device has three inputs permitting the choice of either leading-edge or trailing edge triggering. Pin (A) is an active-LOW transition trigger input and pin (B) is an active-HIGH transition trigger input. A LOW at the clear (CLR) input terminates the output pulse: which also inhibits triggering. An internal connection from CLR to the input gate makes it possible to trigger the circuit by a positive-going signal on CLR as shown in the Truth Table.

To obtain the best and trouble free operation from this device please read the Operating Rules as well as the One-Shot Application Notes carefully and observe recommendations.

### Features

- DC triggered from active-HIGH transition or active-LOW transition inputs
- Retriggerable to 100% duty cycle
- Direct reset terminates output pulse
- Compensated for  $V_{CC}$  and temperature variations
- DTL, TTL compatible
- Input clamp diodes

### Ordering Code:

Order Number	Package Number	Package Description
DM74123N	N16E	16-Lead Plastic Dual-In-Line Package (PDIP), JEDEC MS-001, 0.300 Wide

### Connection Diagram

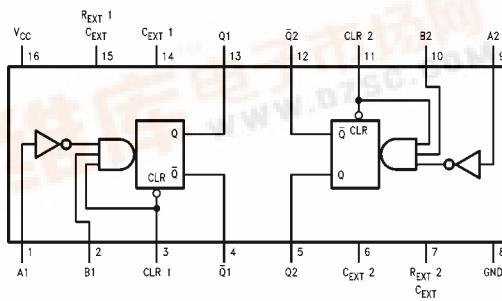

### Triggering Truth Table

Inputs			Response
A	B	CLR	
X	X	L	No Trigger
~	L	X	No Trigger
~	H	H	Trigger
H	~	X	No Trigger
L	~	H	Trigger
L	H	~	Trigger

H = HIGH Voltage Level  
L = LOW Voltage Level  
X = Immaterial

### Functional Description

The basic output pulse width is determined by selection of an external resistor ( $R_X$ ) and capacitor ( $C_X$ ). Once triggered, the basic pulse width may be extended by retriggering the gated active-LOW transition or active-HIGH transition inputs or be reduced by use of the active-LOW

transition clear input. Retriggering to 100% duty cycle is possible by application of an input pulse train whose cycle time is shorter than the output cycle time such that a continuous "HIGH" logic state is maintained at the "Q" output.

DM74123 Dual Retriggerable One-Shot with Clear and Complementary Outputs



## Operating Rules

- An external resistor ( $R_X$ ) and external capacitor ( $C_X$ ) are required for proper operation. The value of  $C_X$  may vary from 0 to any necessary value. For small time constants high-grade mica, glass, polypropylene, polycarbonate, or polystyrene material capacitors may be used. For large time constants use tantalum or special aluminum capacitors. If the timing capacitors have leakages approaching 100 nA or if stray capacitance from either terminal to ground is greater than 50 pF the timing equations may not represent the pulse width the device generates.
- When an electrolytic capacitor is used for  $C_X$  a switching diode is often required for standard TTL one-shots to prevent high inverse leakage current (Figure 1). However, its use in general is not recommended with retriggerable operation.
- The output pulse width ( $T_W$ ) for  $C_X > 1000$  pF is defined as follows:

$$T_W = K R_X C_X (1 + 0.7/R_X)$$

- where: [ $R_X$  is in Kilo-ohm]  
 [ $C_X$  is in pico Farad]  
 [ $T_W$  is in nano second]  
 [ $K = 0.28$ ]

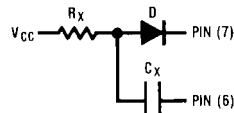

FIGURE 1.

- For  $C_X < 1000$  pF see Figure 2 for  $T_W$  vs.  $C_X$  family curves with  $R_X$  as a parameter:

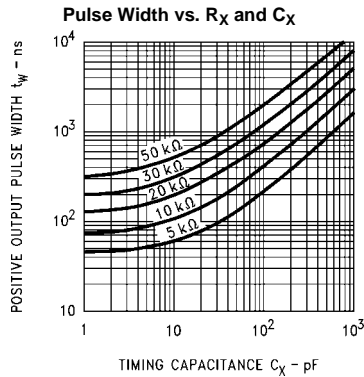
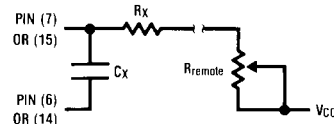

FIGURE 2.

- To obtain variable pulse width by remote trimming, the following circuit is recommended:



Note: " $R_{remote}$ " should be as close to the one-shot as possible.

FIGURE 3.

- The retriggerable pulse width is calculated as shown below:

$$T = T_W + t_{PLH} = K \times R_X \times C_X + t_{PLH}$$

The retriggered pulse width is equal to the pulse width plus a delay time period (Figure 4).

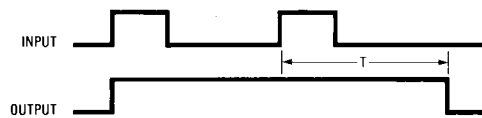

FIGURE 4.

- Under any operating condition  $C_X$  and  $R_X$  must be kept as close to the one-shot device pins as possible to minimize stray capacitance, to reduce noise pick-up, and to reduce  $I \times R$  and  $L di/dt$  voltage developed along their connecting paths. If the lead length from  $C_X$  to pins (6) and (7) or pins (14) and (15) is greater than 3 cm, for example, the output pulse width might be quite different from values predicted from the appropriate equations. A non-inductive and low capacitive path is necessary to ensure complete discharge of  $C_X$  in each cycle of its operation so that the output pulse width will be accurate.
- $V_{CC}$  and ground wiring should conform to good high-frequency standards and practices so that switching transients on the  $V_{CC}$  and ground return leads do not cause interaction between one-shots. A 0.01  $\mu F$  to 0.10  $\mu F$  bypass capacitor (disk ceramic or monolithic type) from  $V_{CC}$  to ground is necessary on each device. Furthermore, the bypass capacitor should be located as close to the  $V_{CC}$  pin as space permits.

Note: For further detailed device characteristics and output performance please refer to the One-Shot Application Note, AN-366.

## Absolute Maximum Ratings<sup>(Note 1)</sup>

Supply Voltage	7V
Input Voltage	5.5V
Operating Free Air Temperature Range	0°C to +70°C
Storage Temperature	-65°C to +150°C

**Note 1:** The "Absolute Maximum Ratings" are those values beyond which the safety of the device cannot be guaranteed. The device should not be operated at these limits. The parametric values defined in the Electrical Characteristics tables are not guaranteed at the absolute maximum ratings. The "Recommended Operating Conditions" table will define the conditions for actual device operation.

## Recommended Operating Conditions

Symbol	Parameter	Min	Nom	Max	Units
V <sub>CC</sub>	Supply Voltage	4.75	5	5.25	V
V <sub>IH</sub>	HIGH Level Input Voltage	2			V
V <sub>IL</sub>	LOW Level Input Voltage			0.8	V
I <sub>OH</sub>	HIGH Level Output Current			-0.8	mA
I <sub>OL</sub>	LOW Level Output Current			16	mA
t <sub>W</sub>	Pulse Width (Note 2)	A or B HIGH 40 A or B LOW 40 Clear LOW 40			ns
T <sub>WQ</sub> (Min)	Minimum Width of Pulse at Q (Note 2)	A or B		65	ns
R <sub>EXT</sub>	External Timing Resistor	5		50	kΩ
C <sub>EXT</sub>	External Timing Capacitance	No Restriction			μF
C <sub>WIRE</sub>	Wiring Capacitance at R <sub>EXT</sub> /C <sub>EXT</sub> Terminal (Note 2)			50	pF
T <sub>A</sub>	Free Air Operating Temperature	0		70	°C

**Note 2:** T<sub>A</sub> = 25°C and V<sub>CC</sub> = 5V.

## Electrical Characteristics

over recommended operating free air temperature range (unless otherwise noted)

Symbol	Parameter	Conditions	Min	Typ (Note 3)	Max	Units
V <sub>I</sub>	Input Clamp Voltage	V <sub>CC</sub> = Min, I <sub>I</sub> = -12 mA			-1.5	V
V <sub>OH</sub>	HIGH Level Output Voltage	V <sub>CC</sub> = Min, I <sub>OH</sub> = Max V <sub>IL</sub> = Max, V <sub>IH</sub> = Min	2.5	3.4		V
V <sub>OL</sub>	LOW Level Output Voltage	V <sub>CC</sub> = Min, I <sub>OL</sub> = Max V <sub>IH</sub> = Min, V <sub>IL</sub> = Max		0.2	0.4	V
I <sub>I</sub>	Input Current @ Max Input Voltage	V <sub>CC</sub> = Max, V <sub>I</sub> = 5.5V			1	mA
I <sub>IH</sub>	HIGH Level Input Current	V <sub>CC</sub> = Max V <sub>I</sub> = 2.4V	Data		40	μA
I <sub>IL</sub>	Low Level Input Current	V <sub>CC</sub> = Max, V <sub>I</sub> = 0.4V	Clear		80	μA
I <sub>OS</sub>	Short Circuit Output Current	V <sub>CC</sub> = Max (Note 4)			-3.2	mA
I <sub>CC</sub>	Supply Current	V <sub>CC</sub> = Max (Note 5)(Note 6)	-10	46	-40	mA
					66	mA

**Note 3:** All typicals are at V<sub>CC</sub> = 5V, T<sub>A</sub> = 25°C.

**Note 4:** Not more than one output should be shorted at a time.

**Note 5:** Quiescent I<sub>CC</sub> is measured (after clearing) with 2.4V applied to all clear and A inputs, B inputs grounded, all outputs OPEN, C<sub>EXT</sub> = 0.02 μF, and R<sub>EXT</sub> = 25 kΩ.

**Note 6:** I<sub>CC</sub> is measured in the triggered state with 2.4V applied to all clear and B inputs, A inputs grounded, all outputs OPEN, C<sub>EXT</sub> = 0.02 μF, and R<sub>EXT</sub> = 25 kΩ.

## Switching Characteristics

at  $V_{CC} = 5V$  and  $T_A = 25^\circ C$

Symbol	Parameter	From (Input) To (Output)	$C_L = 15 \text{ pF}, R_L = 400\Omega$ $C_{EXT} = 1000 \text{ pF}, R_{EXT} = 10 \text{ K}\Omega$		Units
			Min	Max	
$t_{PLH}$	Propagation Delay Time LOW-to-HIGH Level Output	$\bar{A}$ to Q		33	ns
$t_{PLH}$	Propagation Delay Time LOW-to-HIGH Level Output	B to Q		28	ns
$t_{PHL}$	Propagation Delay Time HIGH-to-LOW Level Output	$\bar{A}$ to $\bar{Q}$		40	ns
$t_{PHL}$	Propagation Delay Time HIGH-to-LOW Level Output	B to $\bar{Q}$		36	ns
$t_{PLH}$	Propagation Delay Time LOW-to-HIGH Level Output	Clear to $\bar{Q}$		40	ns
$t_{PHL}$	Propagation Delay Time HIGH-to-LOW Level Output	$\bar{\text{Clear}}$ to Q		27	ns
$t_{W(out)}$	Output Pulse Width (Note 7)	A or B to Q	3.08	3.76	$\mu s$

**Note 7:**  $C_{EXT} = 1000 \text{ pF}, R_{EXT} = 10 \text{ k}\Omega$

**Physical Dimensions** inches (millimeters) unless otherwise noted

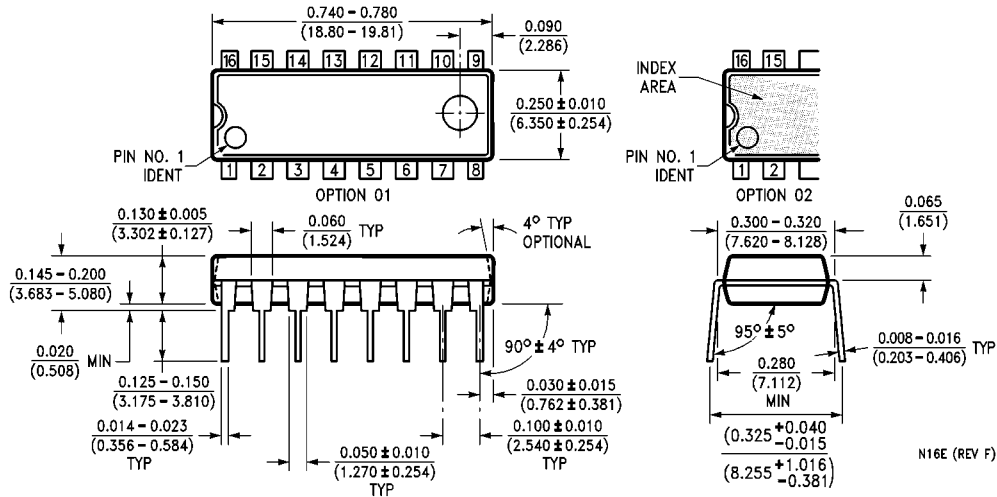

**16-Lead Plastic Dual-In-Line Package (PDIP), JEDEC MS-001, 0.300 Wide  
Package Number N16E**

Fairchild does not assume any responsibility for use of any circuitry described, no circuit patent licenses are implied and Fairchild reserves the right at any time without notice to change said circuitry and specifications.

**LIFE SUPPORT POLICY**

FAIRCHILD'S PRODUCTS ARE NOT AUTHORIZED FOR USE AS CRITICAL COMPONENTS IN LIFE SUPPORT DEVICES OR SYSTEMS WITHOUT THE EXPRESS WRITTEN APPROVAL OF THE PRESIDENT OF FAIRCHILD SEMICONDUCTOR CORPORATION. As used herein:

1. Life support devices or systems are devices or systems which, (a) are intended for surgical implant into the body, or (b) support or sustain life, and (c) whose failure to perform when properly used in accordance with instructions for use provided in the labeling, can be reasonably expected to result in a significant injury to the user.
2. A critical component in any component of a life support device or system whose failure to perform can be reasonably expected to cause the failure of the life support device or system, or to affect its safety or effectiveness.

[www.fairchildsemi.com](http://www.fairchildsemi.com)