

**FAIRCHILD**  
SEMICONDUCTOR™

September 1991  
Revised November 1999

## 74ABT245 Octal Bi-Directional Transceiver with 3-STATE Outputs

### General Description

The ABT245 contains eight non-inverting bidirectional buffers with 3-STATE outputs and is intended for bus-oriented applications. Current sinking capability is 64 mA on both the A and B ports. The Transmit/Receive (T/R) input determines the direction of data flow through the bidirectional transceiver. Transmit (active HIGH) enables data from A Ports to B Ports; Receive (active LOW) enables data from B Ports to A Ports. The Output Enable input, when HIGH, disables both A and B ports by placing them in a HIGH Z condition.

### Features

- Bidirectional non-inverting buffers
- A and B output sink capability of 64 mA, source capability of 32 mA
- Guaranteed output skew
- Guaranteed multiple output switching specifications
- Output switching specified for both 50 pF and 250 pF loads
- Guaranteed simultaneous switching, noise level and dynamic threshold performance
- Guaranteed latchup protection
- High impedance glitch-free bus loading during entire power up and power down cycle
- Non-destructive hot insertion capability
- Disable time is less than enable time to avoid bus contention

### Ordering Code:

Order Number	Package Number	Package Description
74ABT245CSC	M20B	20-Lead Small Outline Integrated Circuit (SOIC), JEDEC MS-013, 0.300" Wide Body
74ABT245CSJ	M20D	20-Lead Small Outline Package (SOP), EIAJ TYPE II, 5.3mm Wide
74ABT245CMSA	MSA20	20-Lead Shrink Small Outline Package (SSOP), EIAJ TYPE II, 5.3mm Wide
74ABT245CMTC	MTC20	20-Lead Thin Shrink Small Outline Package (TSSOP), JEDEC MO-153, 4.4mm Wide
74ABT245CPC	N20A	20-Lead Plastic Dual-In-Line Package (PDIP), JEDEC MS-001, 0.300" Wide

Device also available in Tape and Reel. Specify by appending suffix letter "X" to the ordering code.

### Connection Diagram

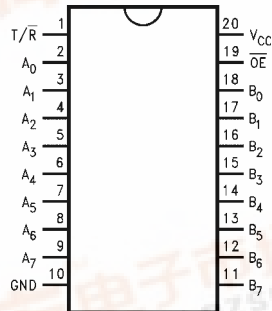

### Pin Descriptions

Pin Names	Description
$\overline{OE}$	Output Enable Input (Active LOW)
T/R	Transmit/Receive Input
A <sub>0</sub> -A <sub>7</sub>	Side A Inputs or 3-STATE Outputs
B <sub>0</sub> -B <sub>7</sub>	Side B Inputs or 3-STATE Outputs

74ABT245 Octal Bi-Directional Transceiver with 3-STATE Outputs



74ABT245

**Logic Symbol**

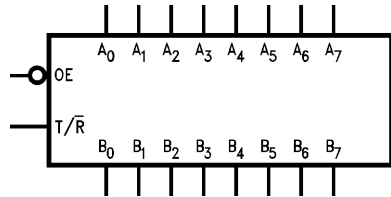

**Truth Table**

Inputs		Output
$\overline{OE}$	$\overline{T/R}$	
L	L	Bus B Data to Bus A
L	H	Bus A Data to Bus B
H	X	HIGH Z State

H = HIGH Voltage Level  
 L = LOW Voltage Level  
 X = Immaterial

**Logic Diagram**

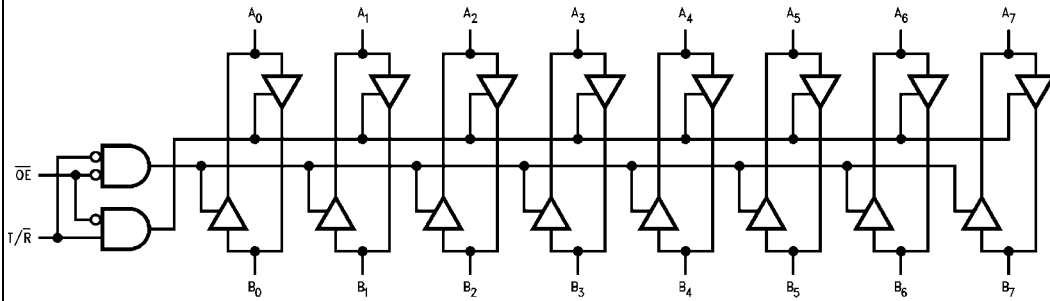

**Absolute Maximum Ratings**(Note 1)

Storage Temperature	-65°C to +150°C
Ambient Temperature under Bias	-55°C to +125°C
Junction Temperature under Bias	-55°C to +150°C
V <sub>CC</sub> Pin Potential to Ground Pin	-0.5V to +7.0V
Input Voltage (Note 2)	-0.5V to +7.0V
Input Current (Note 2)	-30 mA to +5.0 mA
Voltage Applied to Any Output in the Disabled or Power-off State	-0.5V to 5.5V
in the HIGH State	-0.5V to V <sub>CC</sub>
Current Applied to Output in LOW State (Max)	twice the rated I <sub>OL</sub> (mA)
DC Latchup Source Current	-500 mA
Over Voltage Latchup (I/O)	10V

**Recommended Operating Conditions**

Free Air Ambient Temperature	-40°C to +85°C
Supply Voltage	+4.5V to +5.5V
Minimum Input Edge Rate ( $\Delta V/\Delta t$ )	
Data Input	50 mV/ns
Enable Input	20 mV/ns

**Note 1:** Absolute maximum ratings are values beyond which the device may be damaged or have its useful life impaired. Functional operation under these conditions is not implied.

**Note 2:** Either voltage limit or current limit is sufficient to protect inputs

**DC Electrical Characteristics**

Symbol	Parameter	Min	Typ	Max	Units	V <sub>CC</sub>	Conditions
V <sub>IH</sub>	Input HIGH Voltage	2.0			V		Recognized HIGH Signal
V <sub>IL</sub>	Input LOW Voltage			0.8	V		Recognized LOW Signal
V <sub>CD</sub>	Input Clamp Diode Voltage			-1.2	V	Min	I <sub>IN</sub> = -18 mA ( $\overline{OE}$ , T/ $\overline{R}$ )
V <sub>OH</sub>	Output HIGH Voltage	2.5			V	Min	I <sub>OH</sub> = -3 mA (A <sub>n</sub> , B <sub>n</sub> )
		2.0			V	Min	I <sub>OH</sub> = -32 mA (A <sub>n</sub> , B <sub>n</sub> )
V <sub>OL</sub>	Output LOW Voltage			0.55	V	Min	I <sub>OL</sub> = 64 mA (A <sub>n</sub> , B <sub>n</sub> )
I <sub>IH</sub>	Input HIGH Current		1	1	μA	Max	V <sub>IN</sub> = 2.7V ( $\overline{OE}$ , T/ $\overline{R}$ ) V <sub>IN</sub> = V <sub>CC</sub> ( $\overline{OE}$ , T/ $\overline{R}$ )
I <sub>BVI</sub>	Input HIGH Current Breakdown Test			7	μA	Max	V <sub>IN</sub> = 7.0V ( $\overline{OE}$ , T/ $\overline{R}$ )
I <sub>BVIT</sub>	Input HIGH Current Breakdown Test (I/O)			100	μA	Max	V <sub>IN</sub> = 5.5V (A <sub>n</sub> , B <sub>n</sub> )
I <sub>IL</sub>	Input LOW Current			-1	μA	Max	V <sub>IN</sub> = 0.5V ( $\overline{OE}$ , T/ $\overline{R}$ ) V <sub>IN</sub> = 0.0V ( $\overline{OE}$ , T/ $\overline{R}$ )
V <sub>ID</sub>	Input Leakage Test	4.75			V	0.0	I <sub>ID</sub> = 1.9 μA ( $\overline{OE}$ , T/ $\overline{R}$ ) All Other Pins Grounded
I <sub>IH</sub> + I <sub>OZH</sub>	Output Leakage Current			10	μA	0 - 5.5V	V <sub>OUT</sub> = 2.7V (A <sub>n</sub> , B <sub>n</sub> ); $\overline{OE}$ = 2.0V
I <sub>IL</sub> + I <sub>OZL</sub>	Output Leakage Current			-10	μA	0 - 5.5V	V <sub>OUT</sub> = 0.5V (A <sub>n</sub> , B <sub>n</sub> ); $\overline{OE}$ = 2.0V
I <sub>OS</sub>	Output Short-Circuit Current	-100		-275	mA	Max	V <sub>OUT</sub> = 0.0V (A <sub>n</sub> , B <sub>n</sub> )
I <sub>CEX</sub>	Output HIGH Leakage Current			50	μA	Max	V <sub>OUT</sub> = V <sub>CC</sub> (A <sub>n</sub> , B <sub>n</sub> )
I <sub>ZZ</sub>	Bus Drainage Test			100	μA	0.0	V <sub>OUT</sub> = 5.5V (A <sub>n</sub> , B <sub>n</sub> ); All Others GND
I <sub>CCH</sub>	Power Supply Current			50	μA	Max	All Outputs HIGH
I <sub>CCL</sub>	Power Supply Current			30	mA	Max	All Outputs LOW
I <sub>CCZ</sub>	Power Supply Current			50	μA	Max	$\overline{OE}$ = V <sub>CC</sub> , T/ $\overline{R}$ = GND or V <sub>CC</sub> ; All Other GND or V <sub>CC</sub>
I <sub>CC1</sub>	Additional I <sub>CC</sub> /Input	Outputs Enabled		2.5	mA	Max	V <sub>I</sub> = V <sub>CC</sub> - 2.1V
	Outputs 3-STATE		2.5	mA	$\overline{OE}$ , T/ $\overline{R}$ V <sub>I</sub> = V <sub>CC</sub> - 2.1V		
	Outputs 3-STATE		50	μA	Data Input V <sub>I</sub> = V <sub>CC</sub> - 2.1V All Others at V <sub>CC</sub> or GND.		
I <sub>CCD</sub>	Dynamic I <sub>CC</sub>	No Load		0.1	mA/ MHz	Max	Outputs Open $\overline{OE}$ = GND, T/ $\overline{R}$ = GND or V <sub>CC</sub> One Bit Toggling, 50% Duty Cycle

## DC Electrical Characteristics

(SOIC package)

Symbol	Parameter	Min	Typ	Max	Units	V <sub>CC</sub>	Conditions C <sub>L</sub> = 50 pF, R <sub>L</sub> = 500Ω
V <sub>OLP</sub>	Quiet Output Maximum Dynamic V <sub>OL</sub>		0.7	1.0	V	5.0	T <sub>A</sub> = 25°C (Note 3)
V <sub>OLV</sub>	Quiet Output Minimum Dynamic V <sub>OL</sub>	-1.3	-1.0		V	5.0	T <sub>A</sub> = 25°C (Note 3)
V <sub>OHV</sub>	Minimum HIGH Level Dynamic Output Voltage	2.7	3.1		V	5.0	T <sub>A</sub> = 25°C (Note 5)
V <sub>IHD</sub>	Minimum HIGH Level Dynamic Input Voltage	2.0	1.7		V	5.0	T <sub>A</sub> = 25°C (Note 4)
V <sub>ILD</sub>	Maximum LOW Level Dynamic Input Voltage		0.9	0.6	V	5.0	T <sub>A</sub> = 25°C (Note 4)

**Note 3:** Max number of outputs defined as (n). n-1 data inputs are driven 0V to 3V. One output at LOW. Guaranteed, but not tested.

**Note 4:** Max number of data inputs (n) switching. n-1 inputs switching 0V to 3V. Input-under-test switching: 3V to threshold (V<sub>ILD</sub>), 0V to threshold (V<sub>IHD</sub>). Guaranteed, but not tested.

**Note 5:** Max number of outputs defined as (n). n - 1 data inputs are driven 0V to 3V. One output HIGH. Guaranteed, but not tested.

## AC Electrical Characteristics

(SOIC and SSOP package)

Symbol	Parameter	T <sub>A</sub> = +25°C V <sub>CC</sub> = +5V C <sub>L</sub> = 50 pF			T <sub>A</sub> = -55°C to +125°C V <sub>CC</sub> = 4.5V-5.5V C <sub>L</sub> = 50 pF		T <sub>A</sub> = -40°C to +85°C V <sub>CC</sub> = 4.5V-5.5V C <sub>L</sub> = 50 pF		Units
		Min	Typ	Max	Min	Max	Min	Max	
t <sub>PLH</sub>	Propagation Delay	1.0	2.1	3.6	1.0	4.8	1.0	3.6	ns
t <sub>PHL</sub>	Data to Outputs	1.0	2.4	3.6	1.0	4.8	1.0	3.6	
t <sub>PZH</sub>	Output Enable	1.5	3.2	6.0	1.0	6.7	1.5	6.0	ns
t <sub>PZL</sub>	Time	1.5	3.7	6.0	2.0	7.5	1.5	6.0	
t <sub>PHZ</sub>	Output Disable	1.0	3.6	6.1	1.7	7.4	1.0	6.1	ns
t <sub>PLZ</sub>	Time	1.0	3.3	5.6	1.7	6.5	1.0	5.6	

## Extended AC Electrical Characteristics

(SOIC package)

Symbol	Parameter	-40°C to +85°C V <sub>CC</sub> = 4.5V-5.5V C <sub>L</sub> = 50 pF 8 Outputs Switching (Note 6)			T <sub>A</sub> = -40°C to +85°C V <sub>CC</sub> = 4.5V-5.5V C <sub>L</sub> = 250 pF 1 Output Switching (Note 7)		T <sub>A</sub> = -40°C to +85°C V <sub>CC</sub> = 4.5V-5.5V C <sub>L</sub> = 250 pF 8 Outputs Switching (Note 8)		Units
		Min	Typ	Max	Min	Max	Min	Max	
f <sub>TOGGLE</sub>	Max Toggle Frequency		100						MHz
t <sub>PLH</sub>	Propagation Delay	1.5	5.0		1.5	6.0	2.5	8.5	ns
t <sub>PHL</sub>	Data to Outputs	1.5	5.0		1.5	6.0	2.5	8.5	
t <sub>PZH</sub>	Output Enable Time	1.5	6.5		2.5	7.5	2.5	9.5	ns
t <sub>PZL</sub>	Time	1.5	6.5		2.5	7.5	2.5	11.0	
t <sub>PHZ</sub>	Output Disable Time	1.0	6.5		(Note 9)		(Note 9)		ns
t <sub>PLZ</sub>	Time	1.0	5.6		(Note 9)		(Note 9)		

**Note 6:** This specification is guaranteed but not tested. The limits apply to propagation delays for all paths described switching in phase (i.e., all LOW-to-HIGH, HIGH-to-LOW, etc.).

**Note 7:** This specification is guaranteed but not tested. The limits represent propagation delay with 250 pF load capacitors in place of the 50 pF load capacitors in the standard AC load. This specification pertains to single output switching only.

**Note 8:** This specification is guaranteed but not tested. The limits represent propagation delays for all paths described switching in phase (i.e., all LOW-to-HIGH, HIGH-to-LOW, etc.) with 250 pF load capacitors in place of the 50 pF load capacitors in the standard AC load.

**Note 9:** The 3-STATE delays are dominated by the RC network (500Ω, 250 pF) on the output and have been excluded from the datasheet.

<b>Skew</b> (SOIC package)				
Symbol	Parameter	$T_A = -40^\circ\text{C to } +85^\circ\text{C}$ $V_{CC} = 4.5\text{V} - 5.5\text{V}$ $C_L = 50 \text{ pF}$ 8 Outputs Switching (Note 12)	$T_A = -40^\circ\text{C to } +85^\circ\text{C}$ $V_{CC} = 4.5\text{V} - 5.5\text{V}$ $C_L = 250 \text{ pF}$ 8 Outputs Switching (Note 13)	Units
		Max	Max	
$t_{OSHL}$ (Note 10)	Pin to Pin Skew HL Transitions	1.3	2.3	ns
$t_{OSLH}$ (Note 10)	Pin to Pin Skew LH Transitions	1.0	1.8	ns
$t_{PS}$ (Note 14)	Duty Cycle LH-HL Skew	2.0	3.5	ns
$t_{OST}$ (Note 10)	Pin to Pin Skew LH/HL Transitions	2.0	3.5	ns
$t_{PV}$ (Note 11)	Device to Device Skew LH/HL Transitions	2.0	3.5	ns
<p><b>Note 10:</b> Skew is defined as the absolute value of the difference between the actual propagation delays for any two separate outputs of the same device. The specification applies to any outputs switching HIGH-to-LOW (<math>t_{OSHL}</math>), LOW-to-HIGH (<math>t_{OSLH}</math>), or any combination switching LOW-to-HIGH and/or HIGH-to-LOW (<math>t_{OST}</math>). The specification is guaranteed but not tested.</p> <p><b>Note 11:</b> Propagation delay variation for a given set of conditions (i.e., temperature and <math>V_{CC}</math>) from device to device. This specification is guaranteed but not tested.</p> <p><b>Note 12:</b> This specification is guaranteed but not tested. The limits apply to propagation delays for all paths described switching in phase (i.e., all LOW-to-HIGH, HIGH-to-LOW, etc.)</p> <p><b>Note 13:</b> These specifications guaranteed but not tested. The limits represent propagation delays with 250 pF load capacitors in place of the 50 pF load capacitors in the standard AC load.</p> <p><b>Note 14:</b> This describes the difference between the delay of the LOW-to-HIGH and the HIGH-to-LOW transition on the same pin. It is measured across all the outputs (drivers) on the same chip, the worst (largest delta) number is the guaranteed specification. This specification is guaranteed but not tested.</p>				
<b>Capacitance</b>				
Symbol	Parameter	Typ	Units	Conditions $T_A = 25^\circ\text{C}$
$C_{IN}$	Input Capacitance	5.0	pF	$V_{CC} = 0\text{V}$ ( $\overline{OE}$ , $T/\overline{R}$ )
$C_{I/O}$ (Note 15)	I/O Capacitance	11.0	pF	$V_{CC} = 5.0\text{V}$ ( $A_n$ , $B_n$ )
<p><b>Note 15:</b> <math>C_{I/O}</math> is measured at frequency <math>f = 1 \text{ MHz}</math>, per MIL-STD-883, Method 3012.</p>				

### AC Loading

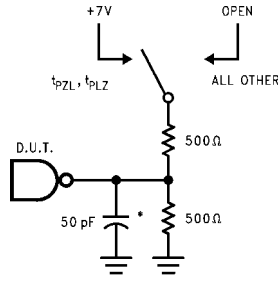

\*Includes jig and probe capacitance

FIGURE 1. Standard AC Test Load

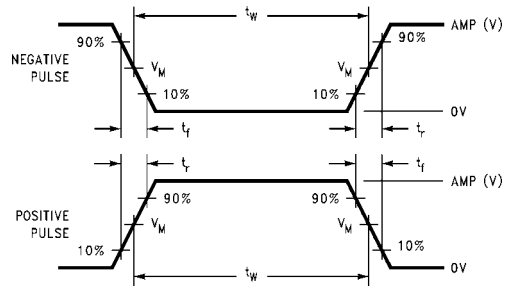

FIGURE 2. Test Input Signal Levels

Amplitude	Rep. Rate	$t_w$	$t_r$	$t_f$
3.0V	1 MHz	500 ns	2.5 ns	2.5 ns

FIGURE 3. Test Input Signal Requirements

### AC Waveforms

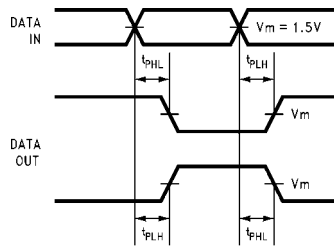

FIGURE 4. Propagation Delay Waveforms for Inverting and Non-Inverting Functions

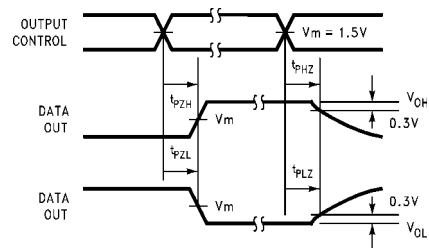

FIGURE 6. 3-STATE Output HIGH and LOW Enable and Disable Times

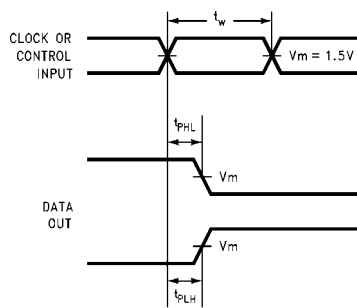

FIGURE 5. Propagation Delay, Pulse Width Waveforms

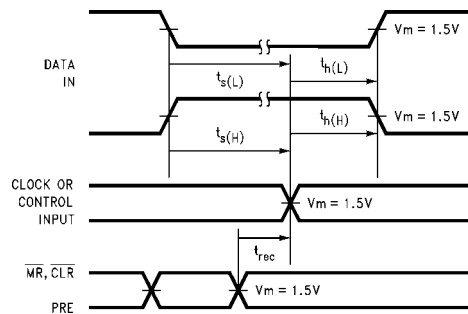
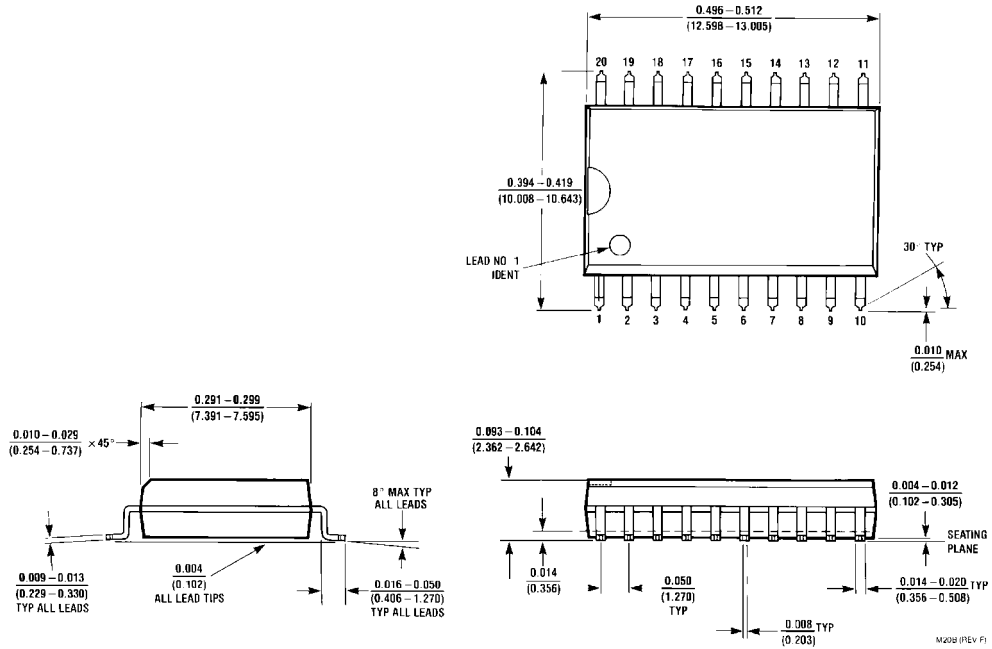

FIGURE 7. Setup Time, Hold Time and Recovery Time Waveforms

**Physical Dimensions** inches (millimeters) unless otherwise noted



**20-Lead Small Outline Integrated Circuit (SOIC), JEDEC MS-013, 0.300" Wide Body  
Package Number M20B**

M20B (REV F)





**Physical Dimensions** inches (millimeters) unless otherwise noted (Continued)

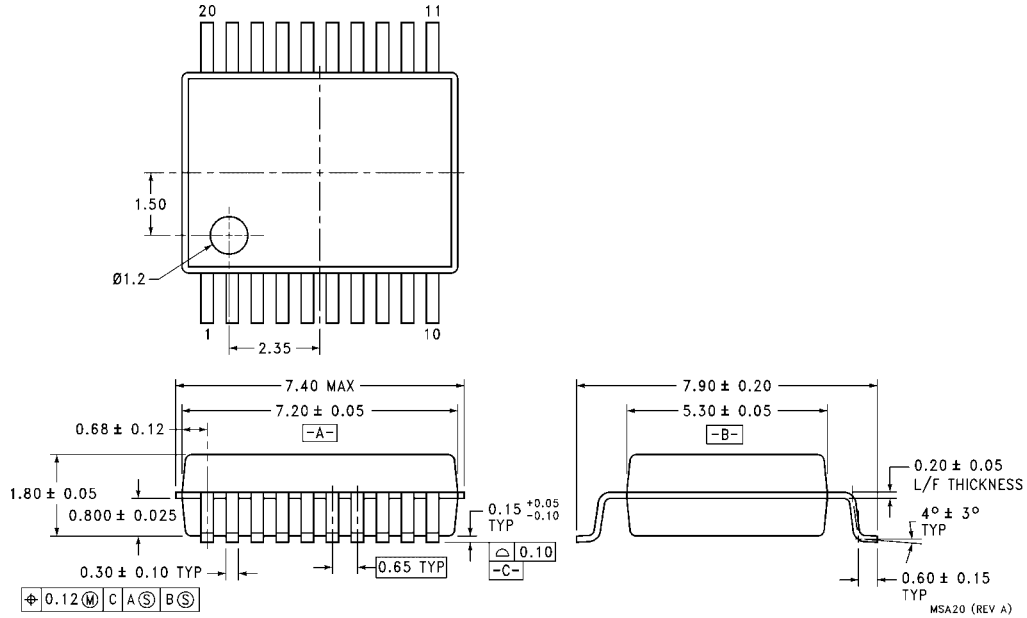

**20-Lead Shrink Small Outline Package (SSOP), EIAJ TYPE II, 5.3mm Wide  
Package Number MSA20**

**Physical Dimensions** inches (millimeters) unless otherwise noted (Continued)

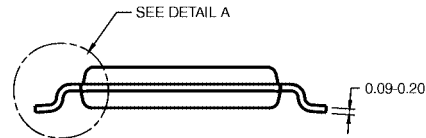
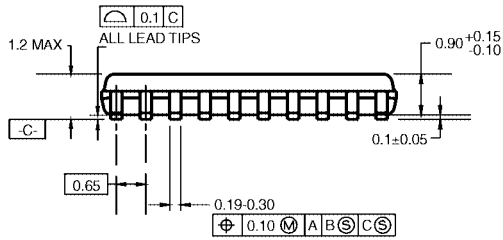
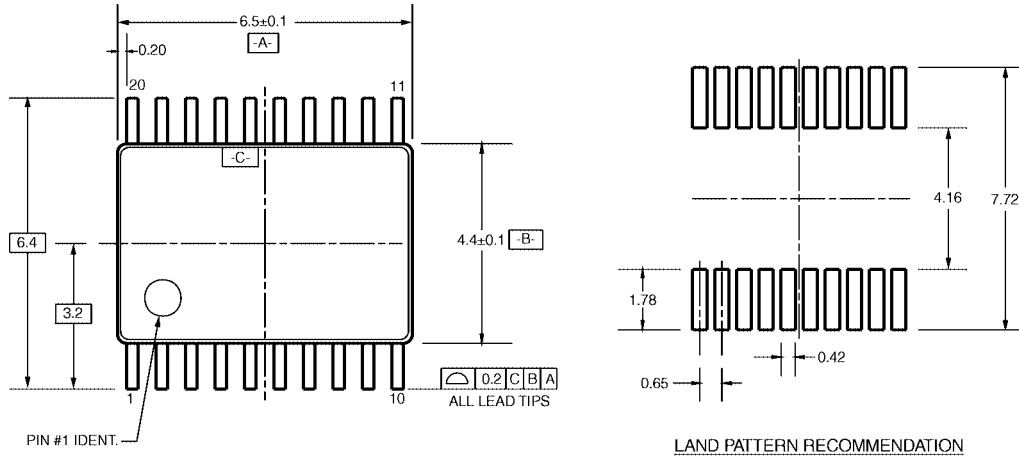

DIMENSIONS ARE IN MILLIMETERS

NOTES:

- A. CONFORMS TO JEDEC REGISTRATION MO-153, VARIATION AC, REF NOTE 6, DATE 7/93.
- B. DIMENSIONS ARE IN MILLIMETERS.
- C. DIMENSIONS ARE EXCLUSIVE OF BURRS, MOLD FLASH, AND TIE BAR EXTRUSIONS.
- D. DIMENSIONS AND TOLERANCES PER ANSI Y14.5M, 1982.

MTC20RevD1

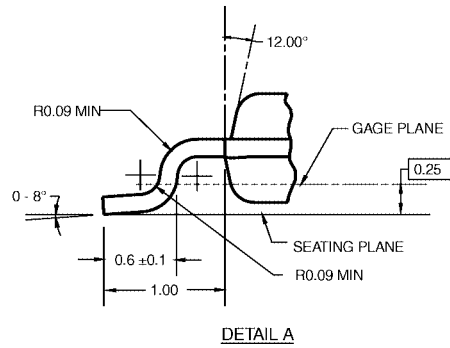

**20-Lead Thin Shrink Small Outline Package (TSSOP), JEDEC MO-153, 4.4mm Wide  
Package Number MTC20**

**Physical Dimensions** inches (millimeters) unless otherwise noted (Continued)

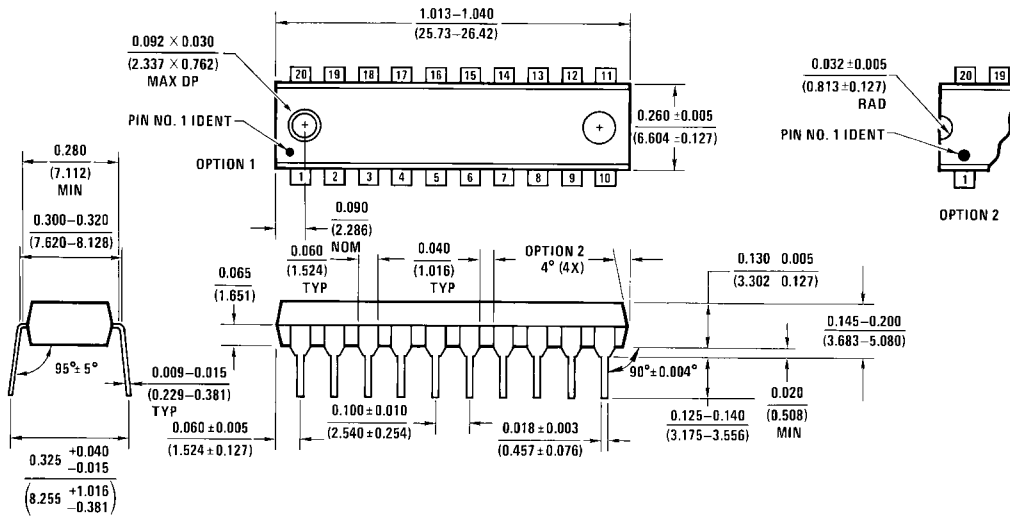

**20-Lead Plastic Dual-In-Line Package (PDIP), JEDEC MS-001, 0.300" Wide  
Package Number N20A**

N20A (REV G)

Fairchild does not assume any responsibility for use of any circuitry described, no circuit patent licenses are implied and Fairchild reserves the right at any time without notice to change said circuitry and specifications.

**LIFE SUPPORT POLICY**

FAIRCHILD'S PRODUCTS ARE NOT AUTHORIZED FOR USE AS CRITICAL COMPONENTS IN LIFE SUPPORT DEVICES OR SYSTEMS WITHOUT THE EXPRESS WRITTEN APPROVAL OF THE PRESIDENT OF FAIRCHILD SEMICONDUCTOR CORPORATION. As used herein:

1. Life support devices or systems are devices or systems which, (a) are intended for surgical implant into the body, or (b) support or sustain life, and (c) whose failure to perform when properly used in accordance with instructions for use provided in the labeling, can be reasonably expected to result in a significant injury to the user.
2. A critical component in any component of a life support device or system whose failure to perform can be reasonably expected to cause the failure of the life support device or system, or to affect its safety or effectiveness.

[www.fairchildsemi.com](http://www.fairchildsemi.com)