

DATA SHEET

74F06, 74F06A, 74F07, 74F07A Inverter/buffer drivers

Product specification

1992 Jul 24

IC15 Data Handbook



Hex inverter/buffer drivers (open-collector)

74F06, 74F06A, 74F07, 74F07A

FEATURES OF 74F06, 74F07

- Open Collector output drive 64mA
- High speed
- 12V output termination voltage
- Symmetrical propagation delays

FEATURES OF 74F06A, 74F07A

- Open Collector output drive 48mA
- High speed
- 30V output termination voltage
- Replaces 74F06 and 74F07
- Improved performance upgrade for 74F06 and 74F07
- Reduced I_{OH} leakage @ 30V

TYPE	TYPICAL PROPAGATION DELAY	TYPICAL SUPPLY CURRENT (TOTAL)
74F06	3.5ns	30mA
74F06A	9.0ns	30mA
74F07	4.5ns	32mA
74F07A	10.0ns	32mA

ORDERING INFORMATION

DESCRIPTION	COMMERCIAL RANGE V _{CC} = 5V ±10%, T _{amb} = 0°C to +70°C	PKG DWG #
14-pin plastic Dual In-line Package	N74F06N, N74F06AN	SOT27-1
14-pin plastic Small Outline	N74F07D, N74F07AD	SOT108-1

PIN CONFIGURATIONS

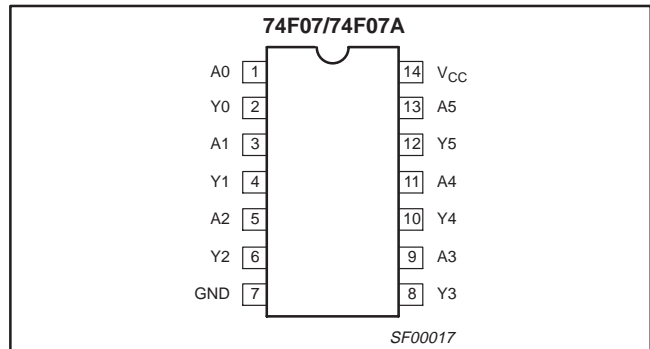
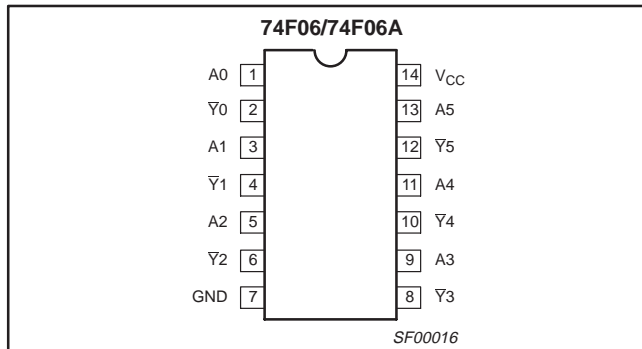

LOGIC SYMBOLS

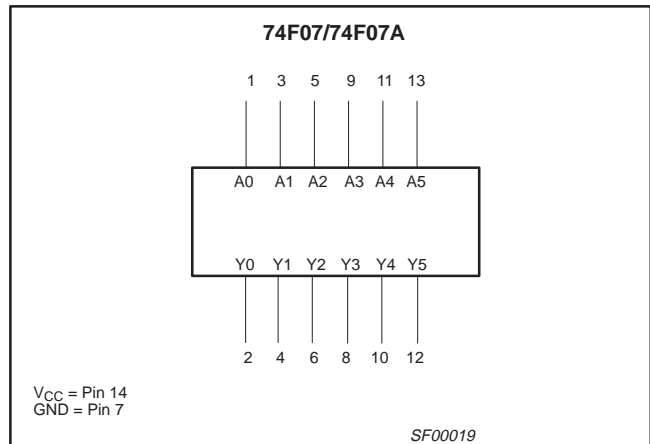
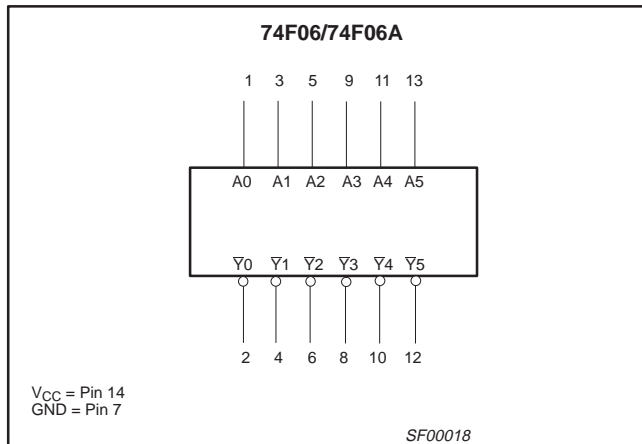

Hex inverter/buffer drivers (open-collector)

74F06, 74F06A,
74F07, 74F07A

IEC/IEEE SYMBOLS

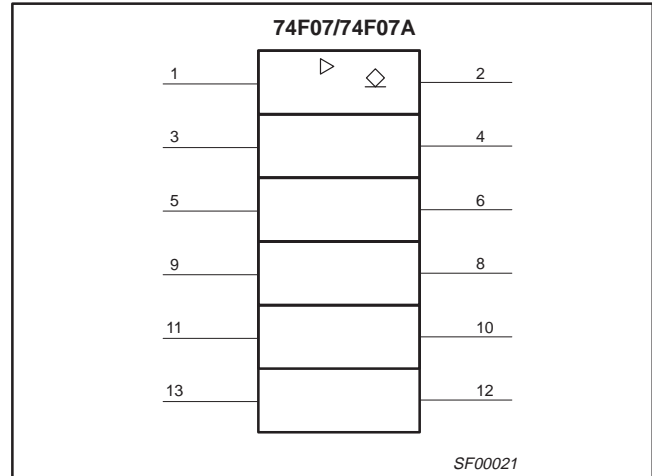
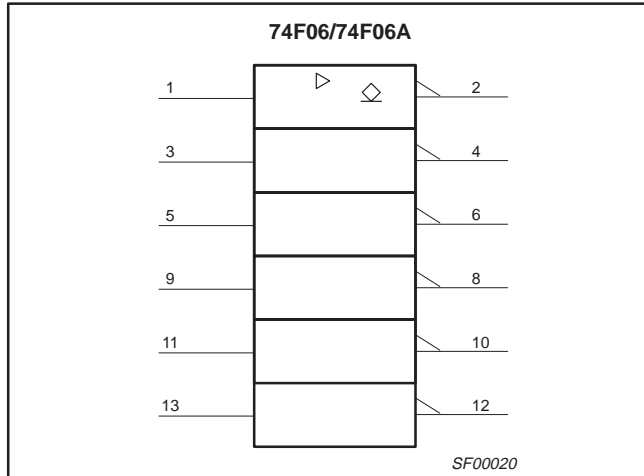

LOGIC DIAGRAMS

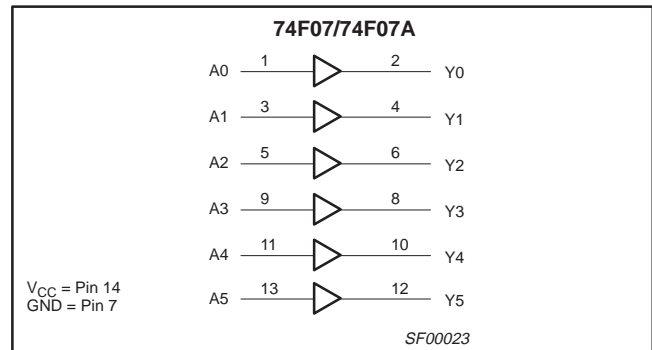
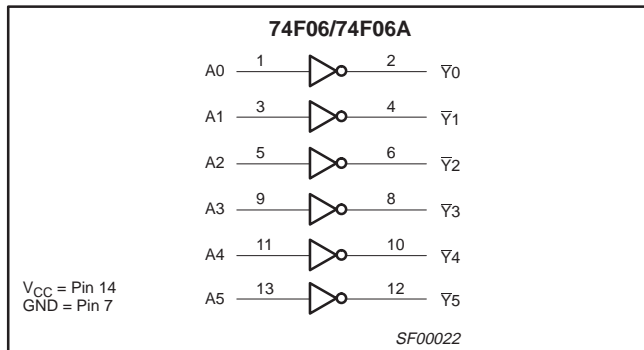

INPUT AND OUTPUT LOADING AND FAN OUT TABLE

PINS	DESCRIPTION	74F (U.L.) HIGH/LOW	LOAD VALUE HIGH/LOW
An	Data inputs ('F06, 'F07)	1.0/1.0	20µA/0.6mA
An	Data inputs ('F06A, 'F07A)	1.0/0.7	20µA/0.4mA
\bar{Y}_n	Data outputs ('F06)	OC/106.7	OC/64mA
\bar{Y}_n	Data outputs ('F06A)	OC/80	OC/48mA
Yn	Data outputs ('F07)	OC/106.7	OC/64mA
Yn	Data outputs ('F07A)	OC/80	OC/48mA

NOTES:

- One (1.0) FAST unit load is defined as: 20µA in the High state and 0.6mA in the Low state.
- OC = Open Collector

FUNCTION TABLE

INPUTS	OUTPUTS	
	'F06, 'F06A	'F07, 'F07A
An	\bar{Y}_n	Yn
L	H	L
H	L	H

NOTES:

- H = High voltage level
- L = Low voltage level

Hex inverter/buffer drivers (open-collector)

74F06, 74F06A,
74F07, 74F07A**ABSOLUTE MAXIMUM RATINGS**

(Operation beyond the limit set forth in this table may impair the useful life of the device.
Unless otherwise noted these limits are over the operating free air temperature range.)

SYMBOL	PARAMETER		RATING	UNIT
V _{CC}	Supply voltage		-0.5 to +7.0	V
V _{IN}	Input voltage		-0.5 to +7.0	V
I _{IN}	Input current		-30 to +5	mA
V _{OUT}	Voltage applied to output in High output state	'F06, 'F07	-0.5 to 12	V
		'F06A, 'F07A	-0.5 to 30	V
I _{OUT}	Current applied to output in Low output state	'F06, 'F07	128	mA
		'F06A, 'F07A	96	mA
T _{amb}	Operating free air temperature range		0 to +70	°C
T _{stg}	Storage temperature range		-65 to +150	°C

RECOMMENDED OPERATING CONDITIONS

SYMBOL	PARAMETER	LIMITS			UNIT
		MIN	NOM	MAX	
V _{CC}	Supply voltage	4.5	5.0	5.5	V
V _{IH}	High-level input voltage	2.0			V
V _{IL}	Low-level input voltage			0.8	V
I _{Ik}	Input clamp current			-18	mA
V _{OH}	High-level output voltage	'F06, 'F07		12	V
		'F06A, 'F07A		30	V
I _{OL}	Low-level output current	'F06, 'F07		64	mA
		'F06A, 'F07A		48	mA
T _{amb}	Operating free air temperature range	0		+70	°C

Hex inverter/buffer drivers (open-collector)

74F06, 74F06A,
74F07, 74F07A**DC ELECTRICAL CHARACTERISTICS**

(Over recommended operating free-air temperature range unless otherwise noted.)

SYMBOL	PARAMETER		TEST CONDITIONS ¹			LIMITS			UNIT
						MIN	TYP ²	MAX	
I _{OH}	High-level output current	'F06, 'F07	V _{CC} = MIN, V _{IL} = MAX, V _{OH} = MAX, V _{IH} = MIN					250	μA
		'F06A, 'F07A						100	μA
V _{OL}	Low-level output voltage		V _{CC} = MIN, V _{IL} = MAX, V _{IH} = MIN	I _{OL} = MAX	±10% V _{CC}	0.30	0.50	V	
					±5% V _{CC}				
V _{IK}	Input clamp voltage		V _{CC} = MIN, I _I = I _{IK}			-0.73	-1.2	V	
I _I	Input current at maximum input voltage		V _{CC} = MAX, V _I = 7.0V				100	μA	
I _{IH}	High-level input current		V _{CC} = MAX, V _I = 2.7V				20	μA	
I _{IL}	Low-level input current	'F06, 'F07	V _{CC} = MAX, V _I = 0.5V				-0.6	mA	
		'F06A, 'F07A					-0.4	mA	
I _{CC}	Supply current (total)	74F06, 74F06A	I _{CCH}	V _{CC} = MAX			5.0	8.0	mA
			I _{CCL}				30	43	mA
		74F07, 74F07A	I _{CCH}				10	14	mA
			I _{CCL}				32	45	mA

NOTES:

- For conditions shown as MIN or MAX, use the appropriate value specified under recommended operating conditions for the applicable type.
- All typical values are at V_{CC} = 5V, T_{amb} = 25°C.
- Not more than one output should be shorted at a time. For testing I_{OS}, the use of high-speed test apparatus and/or sample-and-hold techniques are preferable in order to minimize internal heating and more accurately reflect operational values. Otherwise, prolonged shorting of a High output may raise the chip temperature well above normal and thereby cause invalid readings in other parameter tests. In any sequence of parameter tests, I_{OS} tests should be performed last.

AC ELECTRICAL CHARACTERISTICS

SYMBOL	PARAMETER		TEST CONDITION	LIMITS						UNIT
				V _{CC} = +5.0V T _{amb} = +25°C C _L = 50pF, R _L = 100Ω			V _{CC} = +5.0V ± 10% T _{amb} = 0°C to +70°C C _L = 50pF, R _L = 100Ω			
				Min	Typ	Max	Min	Max		
t _{PLH} t _{PHL}	Propagation delay An to Ȳn	'F06	Waveform 1	2.0	3.5	6.0	1.5	6.5	ns	
		'F06A		1.5	3.0	5.5	1.0	6.0		
t _{PLH} t _{PHL}	Propagation delay An to Ȳn	'F07	Waveform 2	5.0	9.0	11.0	4.0	15.0	ns	
				2.0	4.0	6.0	2.0	8.0		
		'F07A		2.0	4.0	6.0	2.0	6.5	ns	
				3.0	5.0	7.0	2.5	7.5		
				6.0	10.5	13.0	5.0	17.0	ns	
				5.0	7.5	10.0	4.0	13.0		

Hex inverter/buffer drivers (open-collector)

74F06, 74F06A,
74F07, 74F07A

TYPICAL PROPAGATION DELAYS VERSUS LOAD FOR OPEN COLLECTOR OUTPUTS

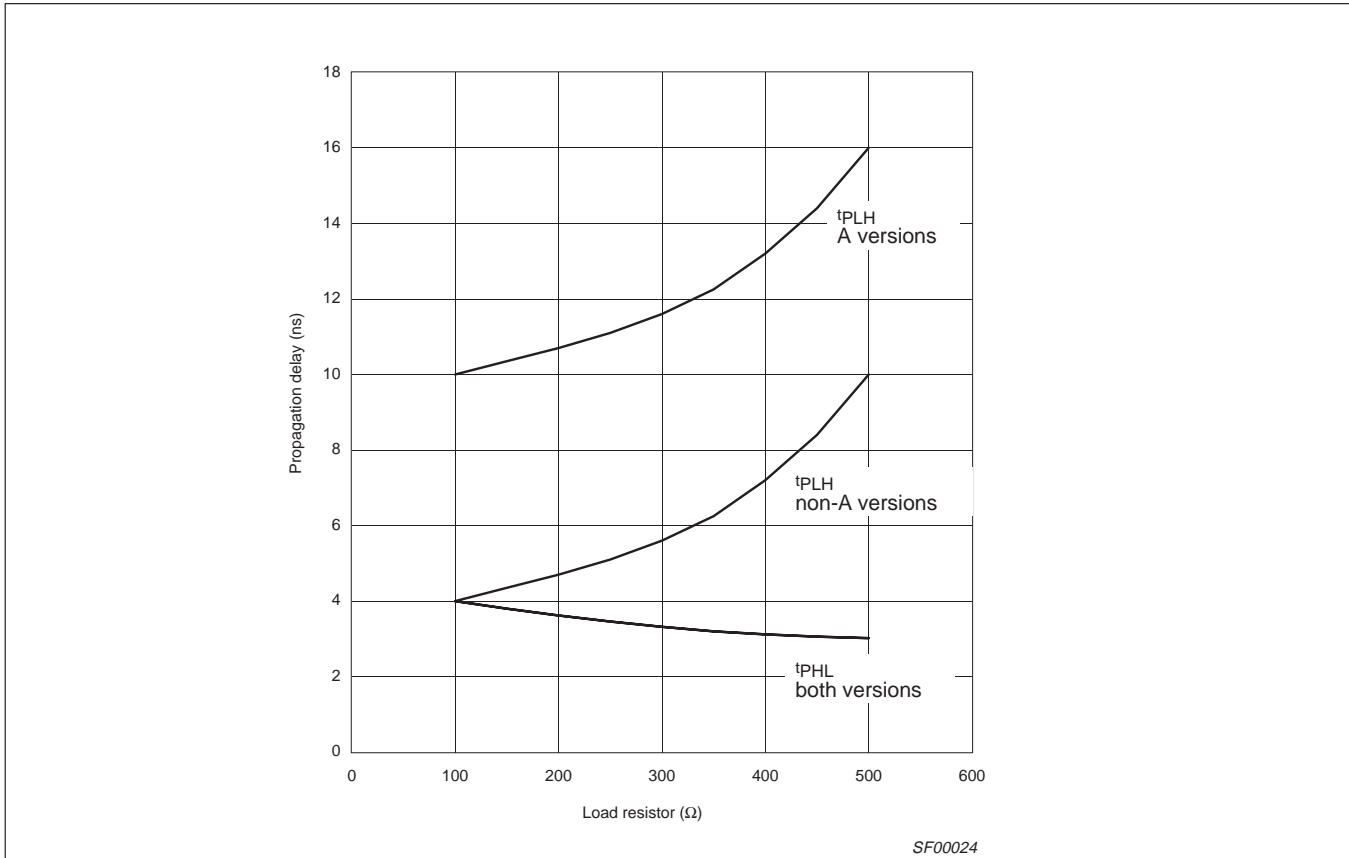

NOTE:

When using Open-Collector parts, the value of the pull-up resistor greatly affects the value of the t_{PLH}. For example, changing the specified pull-up resistor value from 500Ω to 100Ω will improve the t_{PLH} up to 50% with only a slight increase in the t_{PHL}. However, if the value of the pull-up resistor is changed, the user must make certain that the total I_{OL} current through the resistor and the total I_{IL}'s of the receivers does not exceed the I_{OL} maximum specification.

Hex inverter/buffer drivers (open-collector)

74F06, 74F06A,
74F07, 74F07A

AC WAVEFORMS

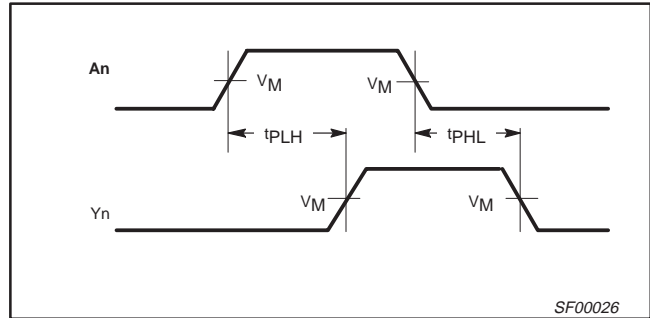
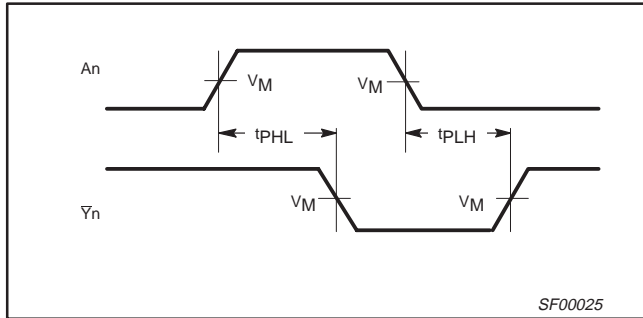

Waveform 1. Propagation delay for inverting outputs

Waveform 2. Propagation delay for non-inverting outputs

NOTE:

For all waveforms, $V_M = 1.5V$.

TEST CIRCUIT AND WAVEFORMS

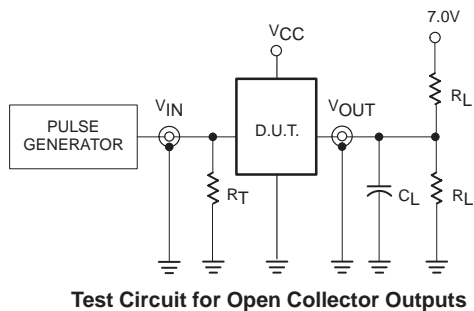

Test Circuit for Open Collector Outputs

DEFINITIONS:

- R_L = Load resistor; see AC electrical characteristics for value.
- C_L = Load capacitance includes jig and probe capacitance; see AC electrical characteristics for value.
- R_T = Termination resistance should be equal to Z_{OUT} of pulse generators.

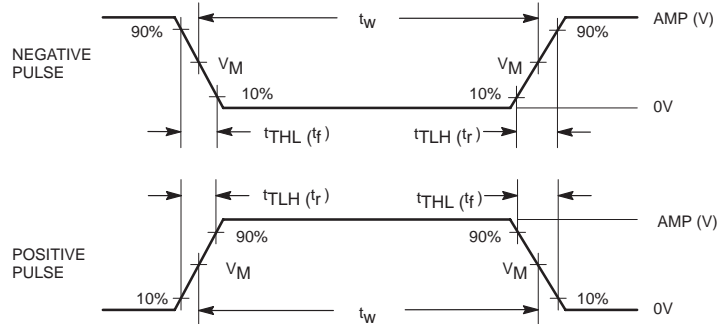

Input Pulse Definition

family	INPUT PULSE REQUIREMENTS					
	amplitude	V_M	rep. rate	t_w	t_{TLH}	t_{THL}
74F	3.0V	1.5V	1MHz	500ns	2.5ns	2.5ns

Inverter/buffer drivers

74F06, 74F06A,
74F07, 74F07A

DIP14: plastic dual in-line package; 14 leads (300 mil)

SOT27-1

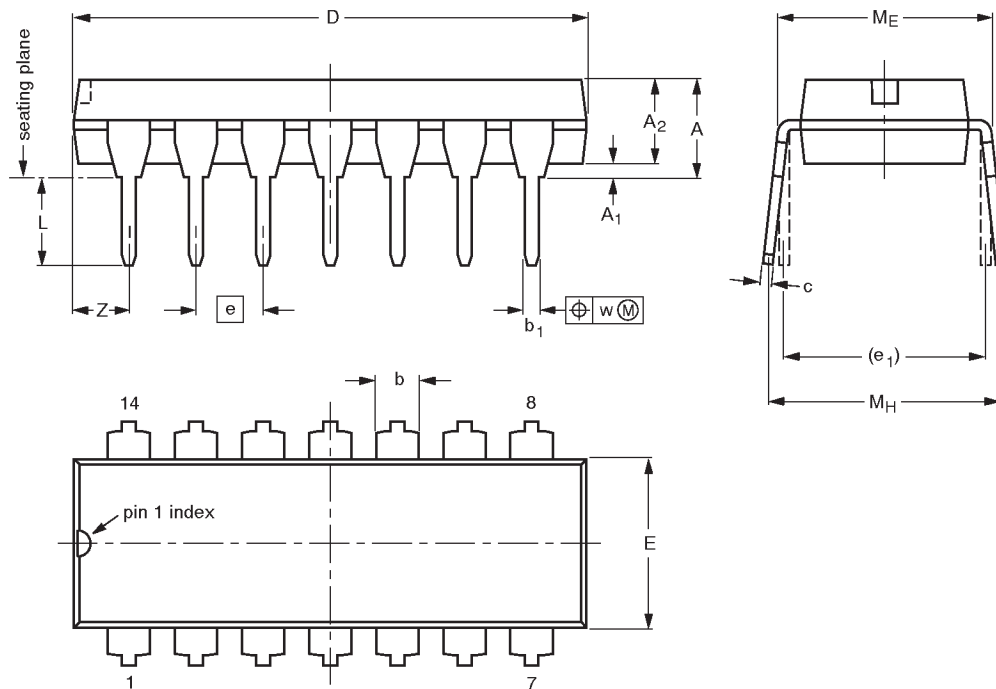

DIMENSIONS (inch dimensions are derived from the original mm dimensions)

UNIT	A max.	A ₁ min.	A ₂ max.	b	b ₁	c	D ⁽¹⁾	E ⁽¹⁾	e	e ₁	L	M _E	M _H	w	Z ⁽¹⁾ max.
mm	4.2	0.51	3.2	1.73 1.13	0.53 0.38	0.36 0.23	19.50 18.55	6.48 6.20	2.54	7.62	3.60 3.05	8.25 7.80	10.0 8.3	0.254	2.2
inches	0.17	0.020	0.13	0.068 0.044	0.021 0.015	0.014 0.009	0.77 0.73	0.26 0.24	0.10	0.30	0.14 0.12	0.32 0.31	0.39 0.33	0.01	0.087

Note

1. Plastic or metal protrusions of 0.25 mm maximum per side are not included.

OUTLINE VERSION	REFERENCES				EUROPEAN PROJECTION	ISSUE DATE
	IEC	JEDEC	EIAJ			
SOT27-1	050G04	MO-001AA				92-11-17 95-03-11

Inverter/buffer drivers

74F06, 74F06A,
74F07, 74F07A

SO14: plastic small outline package; 14 leads; body width 3.9 mm

SOT108-1

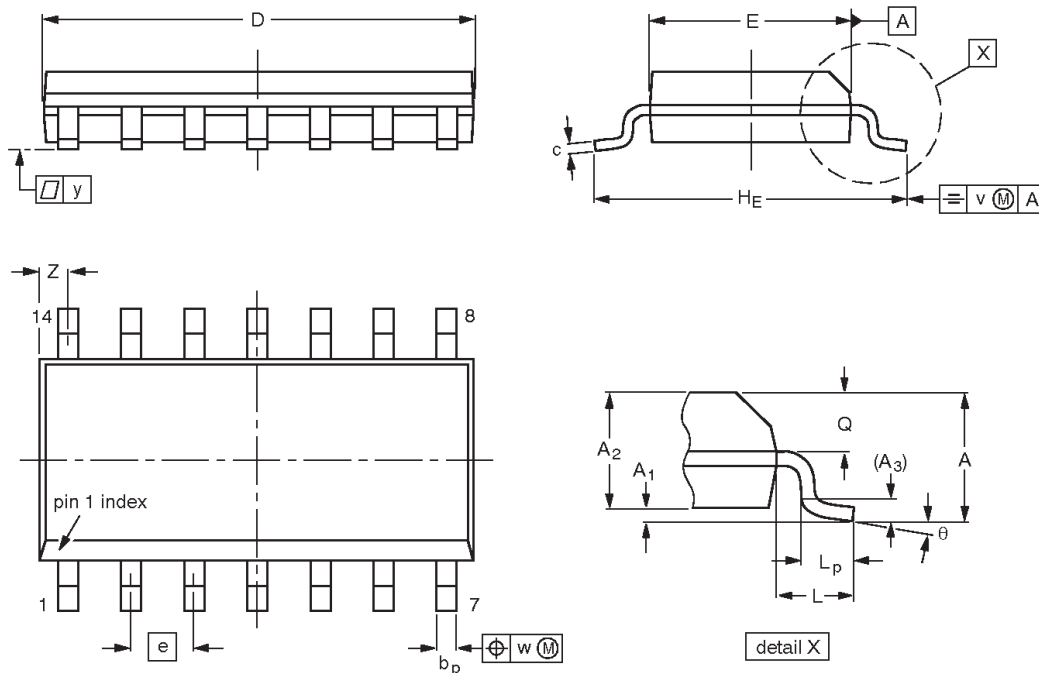

DIMENSIONS (inch dimensions are derived from the original mm dimensions)

UNIT	A max.	A ₁	A ₂	A ₃	b _p	c	D ⁽¹⁾	E ⁽¹⁾	e	HE	L	L _p	Q	v	w	y	Z ⁽¹⁾	θ
mm	1.75	0.25 0.10	1.45 1.25	0.25	0.49 0.36	0.25 0.19	8.75 8.55	4.0 3.8	1.27	6.2 5.8	1.05	1.0 0.4	0.7 0.6	0.25	0.25	0.1	0.7 0.3	8° 0°
inches	0.069	0.010 0.004	0.057 0.049	0.01	0.019 0.014	0.0100 0.0075	0.35 0.34	0.16 0.15	0.050	0.244 0.228	0.041	0.039 0.016	0.028 0.024	0.01	0.01	0.004	0.028 0.012	

Note

1. Plastic or metal protrusions of 0.15 mm maximum per side are not included.

OUTLINE VERSION	REFERENCES				EUROPEAN PROJECTION	ISSUE DATE
	IEC	JEDEC	EIAJ			
SOT108-1	076E06S	MS-012AB				95-01-23 97-05-22

Inverter/buffer drivers

74F06, 74F06A,
74F07, 74F07A

Data sheet status

Data sheet status	Product status	Definition ^[1]
Objective specification	Development	This data sheet contains the design target or goal specifications for product development. Specification may change in any manner without notice.
Preliminary specification	Qualification	This data sheet contains preliminary data, and supplementary data will be published at a later date. Philips Semiconductors reserves the right to make changes at any time without notice in order to improve design and supply the best possible product.
Product specification	Production	This data sheet contains final specifications. Philips Semiconductors reserves the right to make changes at any time without notice in order to improve design and supply the best possible product.

[1] Please consult the most recently issued datasheet before initiating or completing a design.

Definitions

Short-form specification — The data in a short-form specification is extracted from a full data sheet with the same type number and title. For detailed information see the relevant data sheet or data handbook.

Limiting values definition — Limiting values given are in accordance with the Absolute Maximum Rating System (IEC 134). Stress above one or more of the limiting values may cause permanent damage to the device. These are stress ratings only and operation of the device at these or at any other conditions above those given in the Characteristics sections of the specification is not implied. Exposure to limiting values for extended periods may affect device reliability.

Application information — Applications that are described herein for any of these products are for illustrative purposes only. Philips Semiconductors make no representation or warranty that such applications will be suitable for the specified use without further testing or modification.

Disclaimers

Life support — These products are not designed for use in life support appliances, devices or systems where malfunction of these products can reasonably be expected to result in personal injury. Philips Semiconductors customers using or selling these products for use in such applications do so at their own risk and agree to fully indemnify Philips Semiconductors for any damages resulting from such application.

Right to make changes — Philips Semiconductors reserves the right to make changes, without notice, in the products, including circuits, standard cells, and/or software, described or contained herein in order to improve design and/or performance. Philips Semiconductors assumes no responsibility or liability for the use of any of these products, conveys no license or title under any patent, copyright, or mask work right to these products, and makes no representations or warranties that these products are free from patent, copyright, or mask work right infringement, unless otherwise specified.

Philips Semiconductors
811 East Arques Avenue
P.O. Box 3409
Sunnyvale, California 94088-3409
Telephone 800-234-7381

© Copyright Philips Electronics North America Corporation 1998
All rights reserved. Printed in U.S.A.

print code

Date of release: 10-98

Document order number:

9397-750-05054

Let's make things better.