



CYPRESS

CY7C277

32K x 8 Reprogrammable Registered PROM

Features

- Windowed for reprogrammability
- CMOS for optimum speed/power
- High speed
 - 30-ns address set-up
 - 15-ns clock to output
- Low power
 - 60 mW (commercial)
 - 715 mW (military)
- Programmable address latch enable input
- Programmable synchronous or asynchronous output enable
- On-chip edge-triggered output registers
- EPROM technology, 100% programmable
- Slim 300-mil, 28-pin plastic or hermetic DIP
- 5V ±10% V_{CC}, commercial and military
- TTL-compatible I/O
- Direct replacement for bipolar PROMs
- Capable of withstanding greater than 2001V static discharge

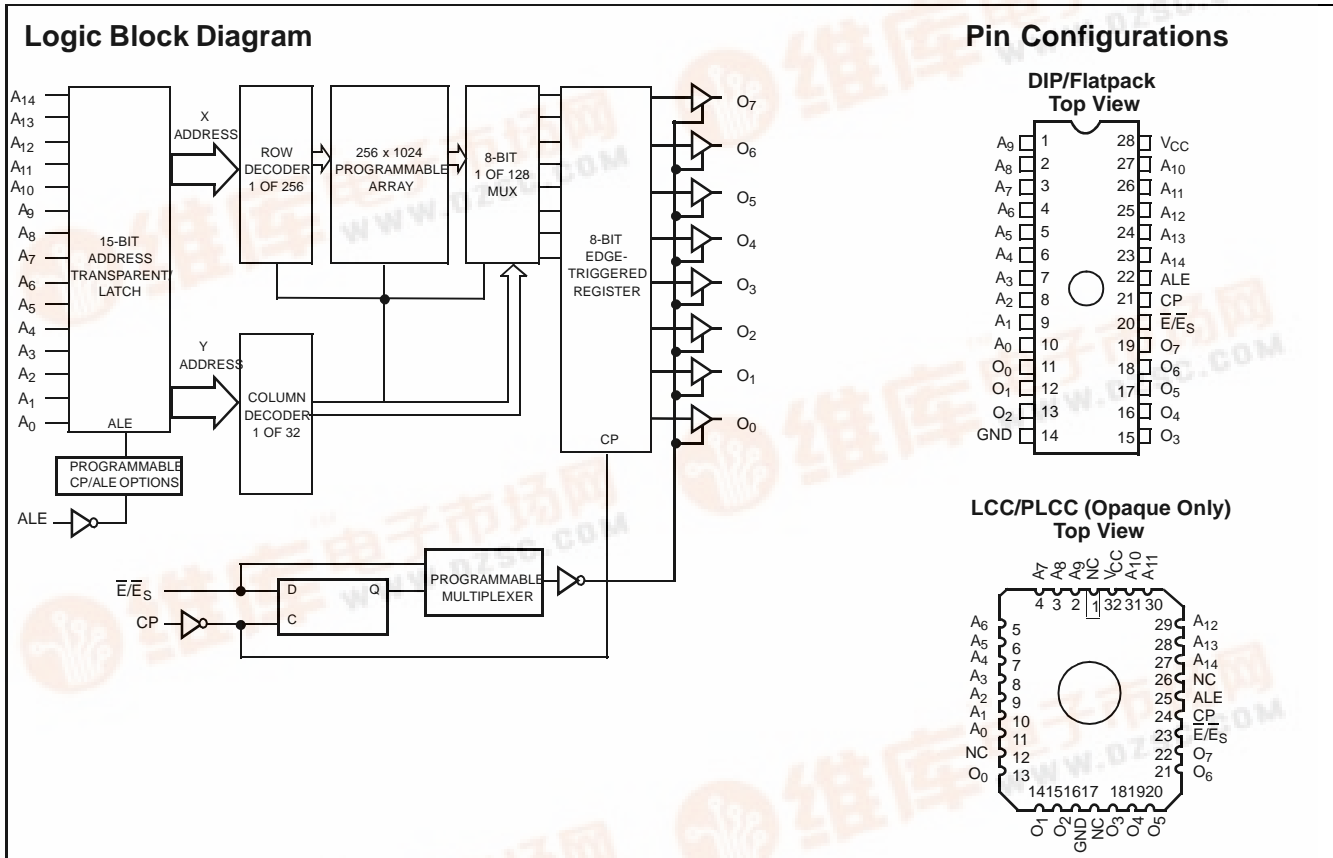

Selection Guide

	7C277-30	7C277-40	7C277-50
Minimum Address Set-Up Time (ns)	30	40	50
Maximum Clock to Output (ns)	15	20	25
Maximum Operating Current (mA)	Com'l	120	120
	Mil		130





Functional Description

The CY7C277 is a high-performance 32K word by 8-bit CMOS PROMs. It is packaged in the slim 28-pin 300-mil package. The ceramic package may be equipped with an erasure window; when exposed to UV light, the PROM is erased and can then be reprogrammed. The memory cells utilize proven EPROM floating-gate technology and byte-wide algorithms.

The CY7C277 offers the advantages of low power, superior performance, and high programming yield. The EPROM cell requires only 12.5V for the supervoltage and low current requirements allow for gang programming. The EPROM cells allow for each memory location to be 100% tested, as each location is written into, erased, and repeatedly exercised prior to encapsulation. Each PROM is also tested for AC performance to guarantee that the product will meet DC and AC specification limits after customer programming.

On the 7C277, the outputs are pipelined through a master-slave register. On the rising edge of CP, data is loaded into the 8-bit edge triggered output register. The \bar{E}/E_S input provides a programmable bit to select between asynchronous and synchronous operation. The default condition is asynchronous. When the asynchronous mode is selected, the \bar{E}/E_S pin operates as an asynchronous output enable. If the synchronous mode is selected, the \bar{E}/E_S pin is sampled on the rising edge of CP to enable and disable the outputs. The 7C277 also provides a programmable bit to enable the Address Latch input. If this bit is not programmed, the device will ignore the ALE pin and the address will enter the device asynchronously. If the ALE function is selected, the address enters the PROM while the ALE pin is active, and is captured when ALE is deasserted.

The user may define the polarity of the ALE signal, with the default being active HIGH.

Maximum Ratings

(Above which the useful life may be impaired. For user guidelines, not tested.)

- Storage Temperature-65°C to +150°C
- Ambient Temperature with Power Applied.....-55°C to +125°C
- Supply Voltage to Ground Potential-0.5V to +7.0V (Pin 24 to Pin 12)
- DC Voltage Applied to Outputs in High Z State.....-0.5V to +7.0V
- DC Input Voltage-3.0V to +7.0V
- DC Program Voltage (Pins 7, 18, 20) 13.0V
- UV Erasure 7258 Wsec/cm²
- Static Discharge Voltage >2001V (per MIL-STD-883, Method 3015)
- Latch-Up Current..... >200 mA

Operating Range

Range	Ambient Temperature	V _{CC}
Commercial	0°C to +70°C	5V ±10%
Industrial ^[1]	-40°C to +85°C	5V ±10%
Military ^[2]	-55°C to +125°C	5V ±10%

Electrical Characteristics Over the Operating Range^[3, 4]

Parameter	Description	Test Conditions	7C277-30		7C277-40, 50		Unit
			Min.	Max.	Min.	Max.	
V _{OH}	Output HIGH Voltage	V _{CC} = Min., I _{OH} = -2.0 mA	2.4		2.4		V
V _{OL}	Output LOW Voltage	V _{CC} = Min., I _{OL} = 8.0 mA		0.4		0.4	V
V _{IH}	Input HIGH Level	Guaranteed Input Logical HIGH Voltage for All Inputs	2.0	V _{CC}	2.0	V _{CC}	V
V _{IL}	Input LOW Level	Guaranteed Input Logical LOW Voltage for All Inputs		0.8		0.8	V
I _{IX}	Input Leakage Current	GND ≤ V _{IN} ≤ V _{CC}	-10	+10	-10	+10	µA
V _{CD}	Input Clamp Diode Voltage		Note 4				
I _{OZ}	Output Leakage Current	0 ≤ V _{OUT} ≤ V _{CC} , Output Disabled ^[5]	-40	+40	-40	+40	µA
I _{OS}	Output Short Circuit Current	V _{CC} = Max., V _{OUT} = 0.0V ^[6]	-20	-90	-20	-90	mA
I _{CC}	Power Supply Current	V _{CC} = Max., $\overline{CS} \geq V_{IH}$ I _{OUT} = 0 mA		120		120	mA
		Commercial				130	
V _{PP}	Programming Supply Voltage		12	13	12	13	V
I _{PP}	Programming Supply Current			50		50	mA
V _{IHP}	Input HIGH Programming Voltage		3.0		3.0		V
V _{ILP}	Input LOW Programming Voltage			0.4		0.4	V

Notes:

1. Contact a Cypress representative for industrial temperature range specifications.
2. T_A is the "instant on" case temperature.
3. See the last page of this specification for Group A subgroup testing information.
4. See "Introduction to CMOS PROMs" in this Book for general information on testing.
5. For devices using the synchronous enable, the device must be clocked after applying these voltages to perform this measurement.
6. For test purposes, not more than one output at a time should be shorted. Short circuit test duration should not exceed 30 seconds.

Capacitance^[4]

Parameter	Description	Test Conditions	Max.	Unit
C_{IN}	Input Capacitance	$T_A = 25^\circ\text{C}$, $f = 1\text{ MHz}$, $V_{CC} = 5.0\text{V}$	10	pF
C_{OUT}	Output Capacitance		10	pF

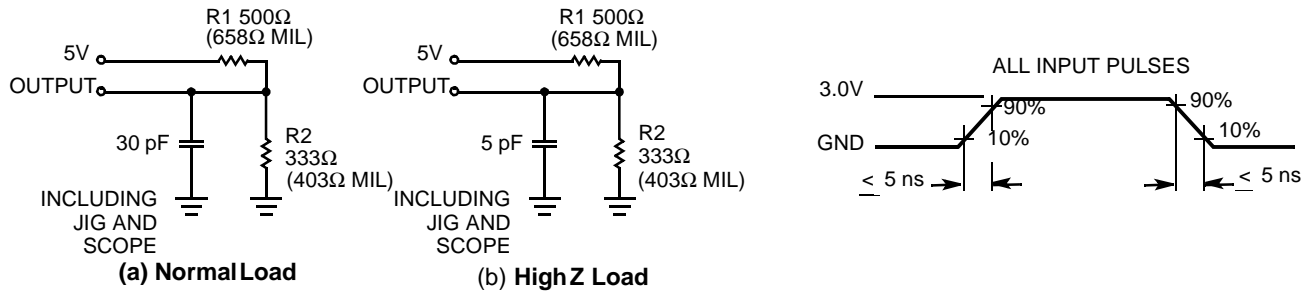
AC Test Loads and Waveforms^[4]

Equivalent to: THÉVENIN EQUIVALENT

CY7C277 Switching Characteristics Over the Operating Range^[3, 4]

Parameter	Description	7C277-30		7C277-40		7C277-50		Unit
		Min.	Max.	Min.	Max.	Min.	Max.	
t_{AL}	Address Set-Up to ALE Inactive	5		10		10		ns
t_{LA}	Address Hold from ALE Inactive	10		10		15		ns
t_{LL}	ALE Pulse Width	10		10		15		ns
t_{SA}	Address Set-Up to Clock HIGH	30		40		50		ns
t_{HA}	Address Hold from Clock HIGH	0		0		0		ns
t_{SES}	\overline{E}_S Set-Up to Clock HIGH	12		15		15		ns
t_{HES}	\overline{E}_S Hold from Clock HIGH	5		10		10		ns
t_{CO}	Clock HIGH to Output Valid		15		20		25	ns
t_{PWC}	Clock Pulse Width	15		20		20		ns
$t_{LZC}^{[7]}$	Output Valid from Clock HIGH		15		20		30	ns
t_{HZC}	Output High Z from Clock HIGH		15		20		30	ns
$t_{LZE}^{[8]}$	Output Valid from \overline{E} LOW		15		20		30	ns
$t_{HZE}^{[8]}$	Output High Z from \overline{E} HIGH		15		20		30	ns

Notes:

7. Applies only when the synchronous (\overline{E}_S) function is used.
8. Applies only when the asynchronous (\overline{E}) function is used.

Architecture Configuration Bits

Architecture Bit	Architecture Verify D ₇ - D ₀		Function
ALE	D ₁	0 = DEFAULT	Input Transparent
		1 = PGMED	Input Latched
ALEP	D ₂	0 = DEFAULT	ALE = Active HIGH
		1 = PGMED	ALE = Active LOW
$\overline{E}/\overline{E}_S$	D ₀	0 = DEFAULT	Asynchronous Output Enable (\overline{E})
		1 = PGMED	Synchronous Output Enable (\overline{E}_S)

Bit Map

Programmer Address (Hex.)	RAM Data
0000	Data
⋮	⋮
7FFF	Data
8000	Control Byte

Architecture Byte (8000)
 D7 D0
 C7 C6 C5 C4 C3 C2 C1 C0

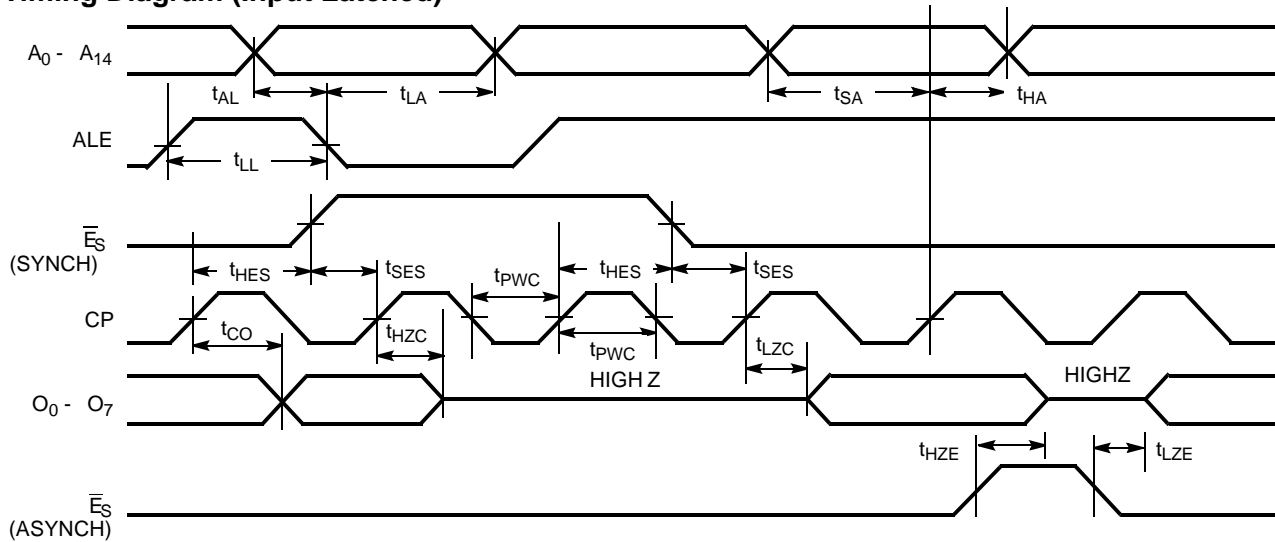
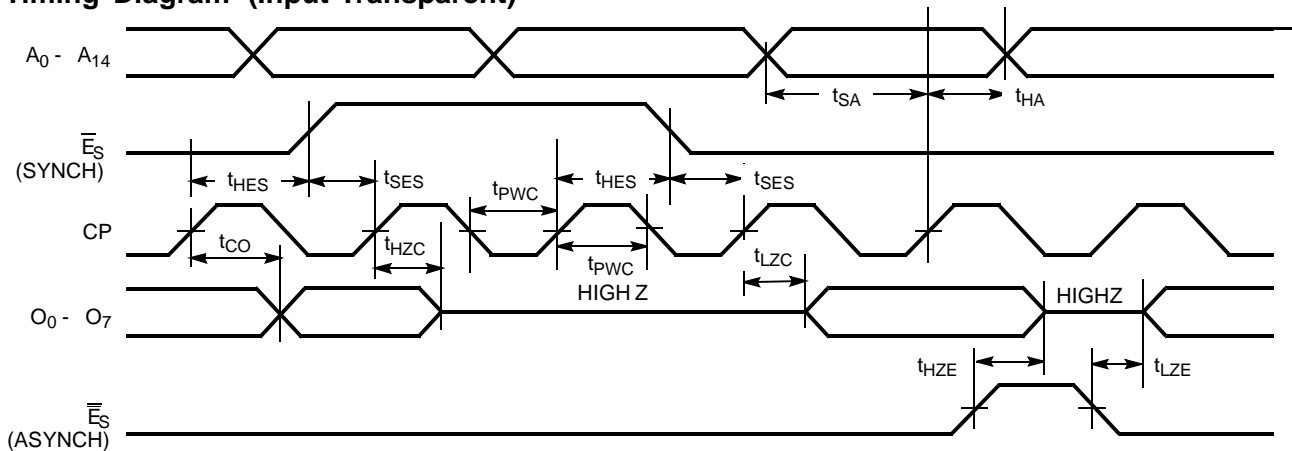
Timing Diagram (Input Latched)^[9]

Timing Diagram (Input Transparent)

Note:

9. ALE is shown with positive polarity.

Programming Information

Programming support is available from Cypress as well as from a number of third-party software vendors. For detailed

programming information, including a listing of software packages, please see the PROM Programming Information located at the end of this section. Programming algorithms can be obtained from any Cypress representative.

Table 1. Mode Selection

Mode	Pin Function ^[10]					
	Read or Output Disable	A ₁₄ -A ₀	E, E _S	CP	ALE	O ₇ -O ₀
	Other	A ₁₄ -A ₀	VFY	PGM	V _{PP}	D ₇ -D ₀
Read		A ₁₄ -A ₀	V _{IL}	V _{IH}	V _{IL}	O ₇ -O ₀
Output Disable		A ₁₄ -A ₀	V _{IH}	X	X	High Z
Program		A ₁₄ -A ₀	V _{IHP}	V _{ILP}	V _{PP}	D ₇ -D ₀
Program Verify		A ₁₄ -A ₀	V _{ILP}	V _{IHP} /V _{ILP}	V _{PP}	O ₇ -O ₀
Program Inhibit		A ₁₄ -A ₀	V _{IHP}	V _{IHP}	V _{PP}	High Z
Blank Check		A ₁₄ -A ₀	V _{ILP}	V _{IHP} /V _{ILP}	V _{PP}	O ₇ -O ₀

Note:

10. X = "don't care" but not to exceed V_{CC} ±5%.

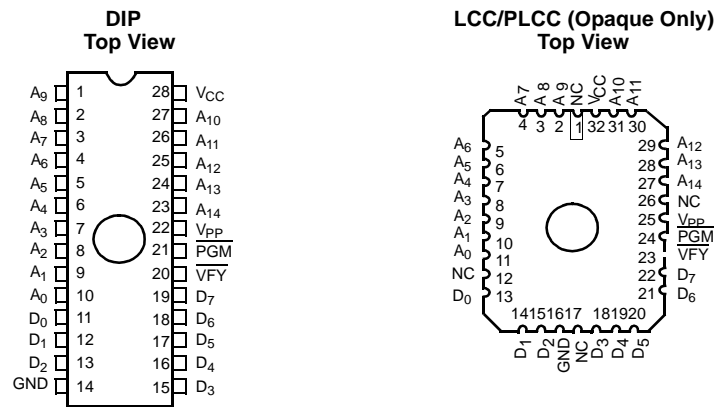
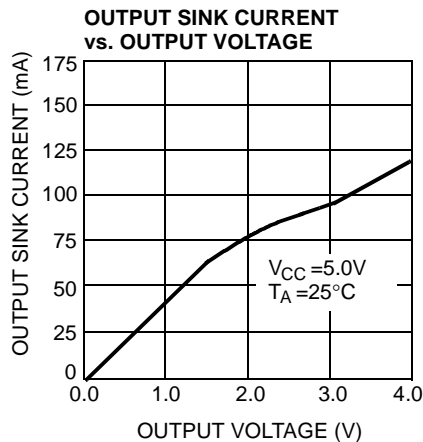
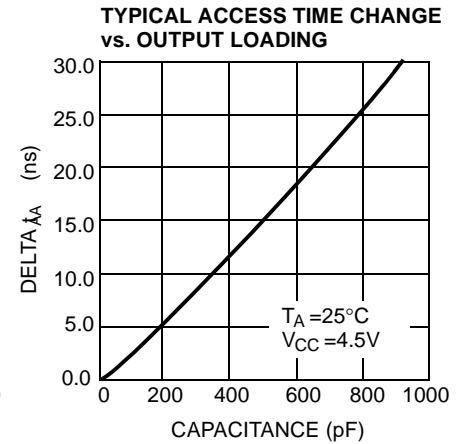
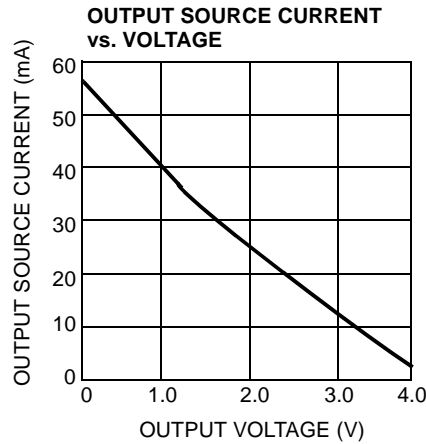
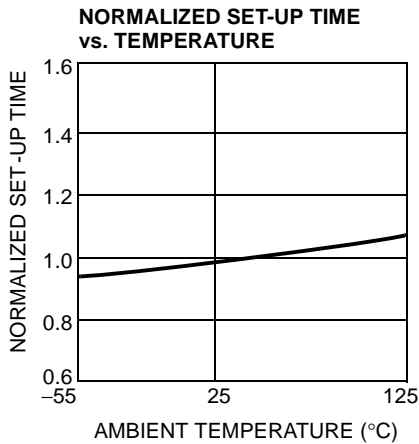
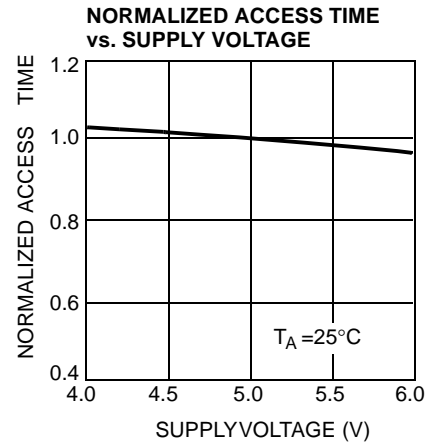
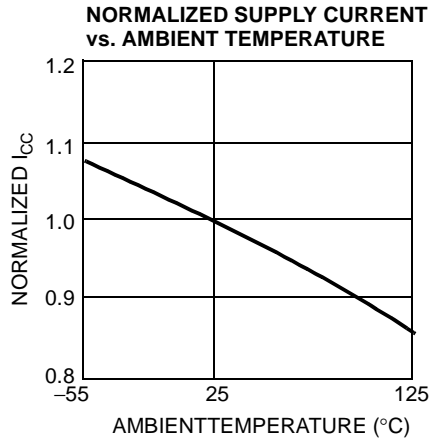
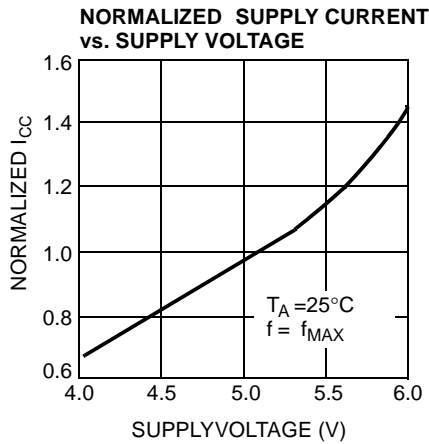

Figure 1. Programming Pinouts

Typical DC and AC Characteristics

Ordering Information^[11]

Speed (ns)	Ordering Code	Package Name	Package Type	Operating Range
30	CY7C277-30JC	J65	32-Lead Plastic Leaded Chip Carrier	Commercial
	CY7C277-30PC	P21	28-Lead (300-Mil) Molded DIP	
	CY7C277-30WC	W22	28-Lead (300-Mil) Windowed CerDIP	
40	CY7C277-40JC	J65	32-Lead Plastic Leaded Chip Carrier	Commercial
	CY7C277-40PC	P21	28-Lead (300-Mil) Molded DIP	
	CY7C277-40WC	W22	28-Lead (300-Mil) Windowed CerDIP	
	CY7C277-40DMB	D22	28-Lead (300-Mil) CerDIP	Military
	CY7C277-40KMB	K74	28-Lead Rectangular Cerpack	
	CY7C277-40LMB	L55	32-Pin Rectangular Leadless Chip Carrier	
	CY7C277-40QMB	Q55	32-Pin Windowed Rectangular Leadless Chip Carrier	
	CY7C277-40TMB	T74	28-Lead Windowed Cerpack	
	CY7C277-40WMB	W22	28-Lead (300-Mil) Windowed CerDIP	
50	CY7C277-50JC	J65	32-Lead Plastic Leaded Chip Carrier	Commercial
	CY7C277-50PC	P21	28-Lead (300-Mil) Molded DIP	
	CY7C277-50WC	W22	28-Lead (300-Mil) Windowed CerDIP	
	CY7C277-50DMB	D22	28-Lead (300-Mil) CerDIP	Military
	CY7C277-50KMB	K74	28-Lead Rectangular Cerpack	
	CY7C277-50LMB	L55	32-Pin Rectangular Leadless Chip Carrier	
	CY7C277-50QMB	Q55	32-Pin Windowed Rectangular Leadless Chip Carrier	
	CY7C277-50TMB	T74	28-Lead Windowed Cerpack	
	CY7C277-50WMB	W22	28-Lead (300-Mil) Windowed CerDIP	

Note:

11. Most of the above products are available in industrial temperature range. Contact a Cypress representative for specifications and product availability.

**MILITARY SPECIFICATIONS
Group A Subgroup Testing**
DC Characteristics

Parameter	Subgroups
V_{OH}	1, 2, 3
V_{OL}	1, 2, 3
V_{IH}	1, 2, 3
V_{IL}	1, 2, 3
I_{IX}	1, 2, 3
I_{OZ}	1, 2, 3
I_{CC}	1, 2, 3

Switching Characteristics

Parameter	Subgroups
t_{SA}	7, 8, 9, 10, 11
t_{HA}	7, 8, 9, 10, 11
t_{CO}	7, 8, 9, 10, 11

Package Diagrams

28-Lead (300-Mil) CerDIP D22
MIL-STD-1835 D-15 Config. A

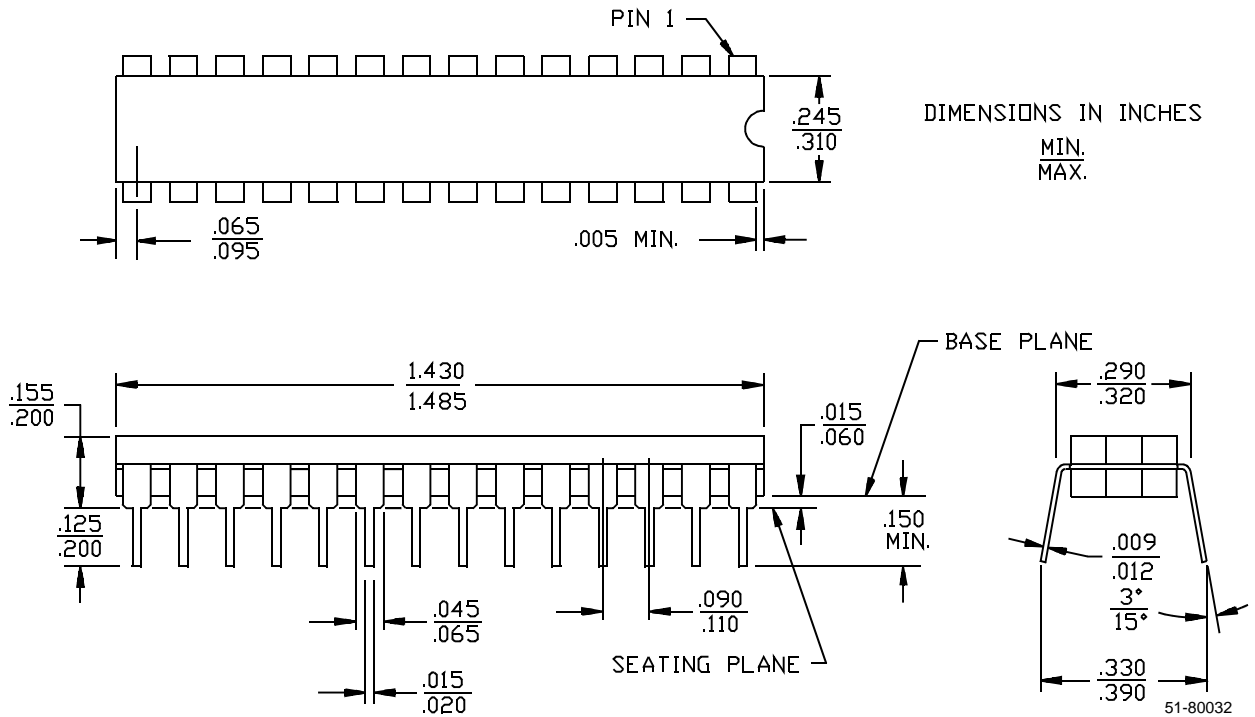

32-Lead Plastic Leaded Chip Carrier J65

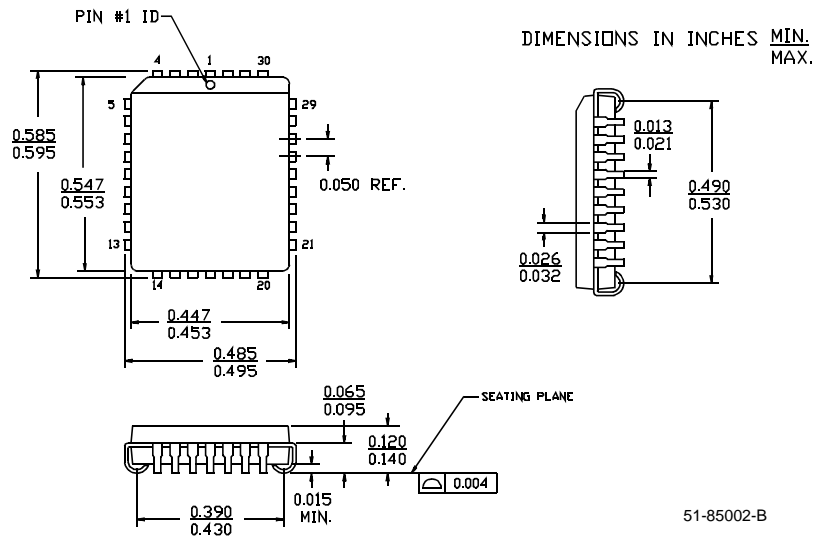

Package Diagrams (continued)

28-Lead Rectangular Cerpack K74

MIL-STD-1835 F-11 Config. A

DIMENSIONS IN INCHES

MIN.
MAX.

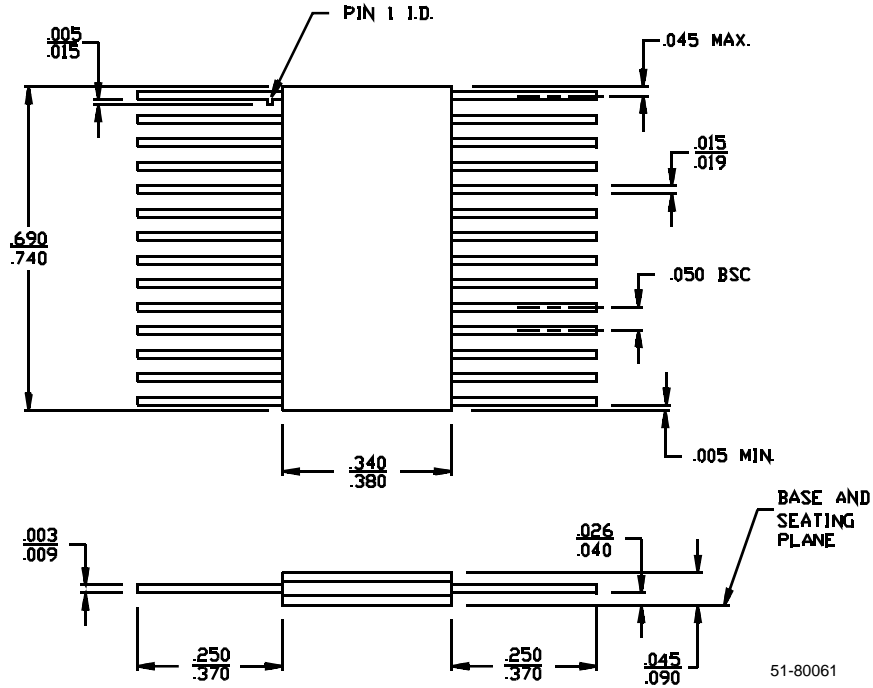

51-80061

Package Diagrams (continued)

32-Pin Rectangular Leadless Chip Carrier L55

MIL-STD-1835 C-12

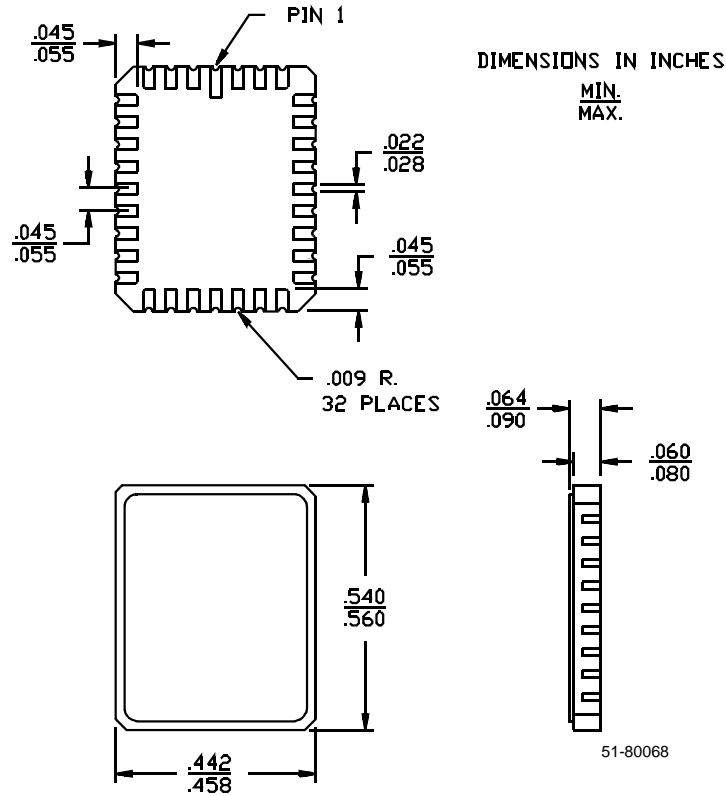

28-Lead (300-Mil) Molded DIP P21

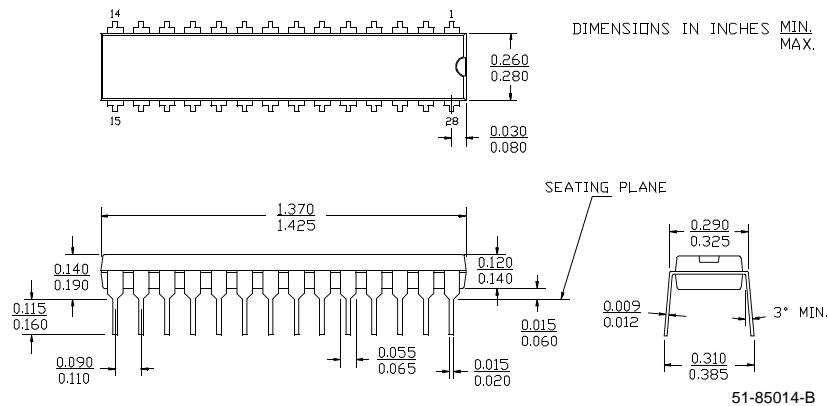

Package Diagrams (continued)

32-Pin Windowed Rectangular Leadless Chip Carrier Q55
MIL-STD-1835 C-12

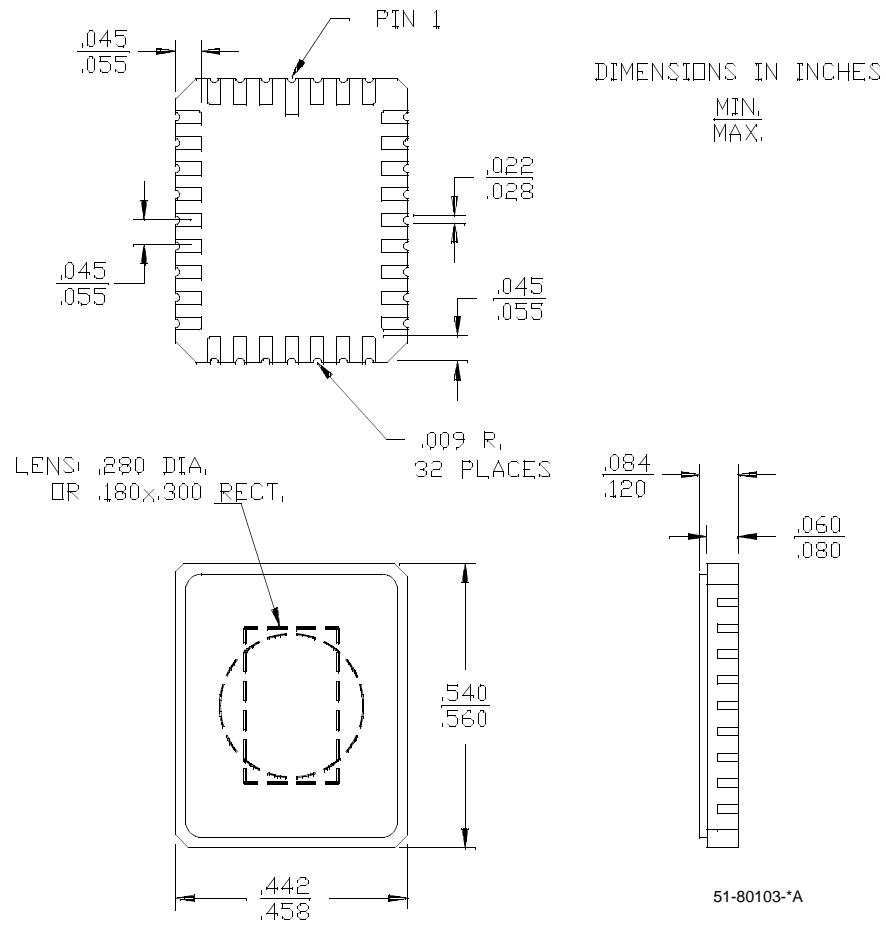

Package Diagrams (continued)

28-Lead Windowed Cerpack T74

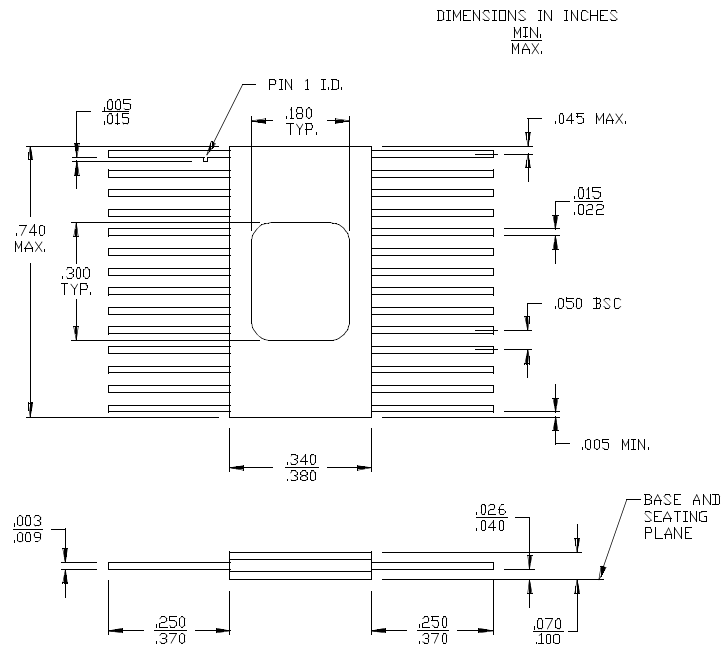

28-Lead (300-Mil) Windowed CerDIP W22
MIL-STD-1835 D-15 Config. A

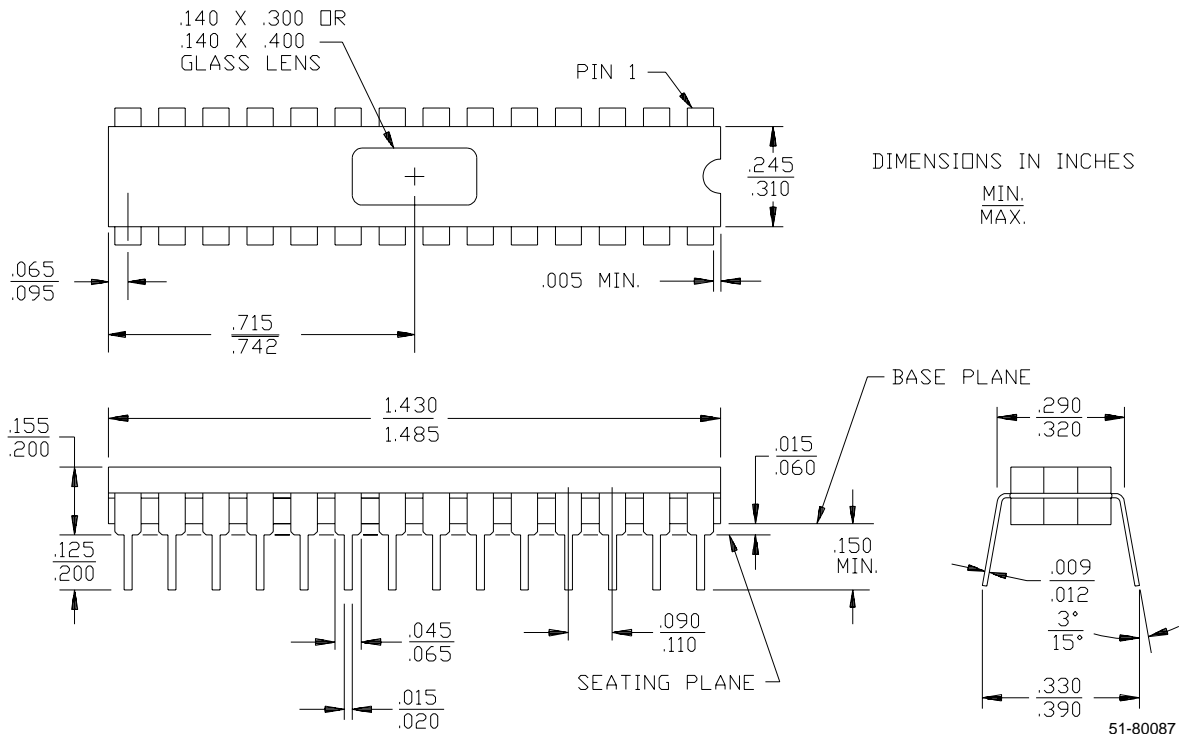



Document Title: CY7C277 32K x 8 Programmable Registered PROM Document Number: 38-04006				
REV.	ECN NO.	Issue Date	Orig. of Change	Description of Change
**	113862	3/8/02	DSG	Change from Spec number: 38-00085 to 38-04006