

250-mA LDO REGULATOR WITH INTEGRATED RESET IN A MSOP8 PACKAGE

SLVS283A – MARCH 2000 – REVISED MARCH 2000

- Open Drain Power-On Reset With 220-ms Delay
- 250-mA Low-Dropout Voltage Regulator
- Available in 1.8-V, 2.5-V, 3-V, Fixed Output and Adjustable Versions
- Dropout Voltage Typically 200 mV at 250 mA (TPS77930)
- Ultra Low 92- μ A Quiescent Current (Typ)
- 8-Pin MSOP (DGK) Package
- Low Noise (55 μ V_{rms}) With No Bypass Capacitor (TPS77918)
- 2% Tolerance Over Specified Conditions For Fixed-Output Versions
- Fast Transient Response
- Thermal Shutdown Protection
- See the TPS773xx and TPS774xx Family of Devices for Active Low Enable

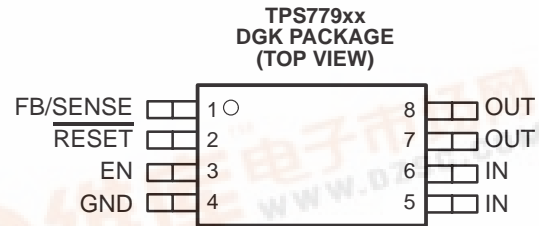

description

The TPS779xx is a low dropout regulator with integrated power-on reset. The device is capable of supplying 250 mA of output current with a dropout of 200 mV (TPS77930). Quiescent current is 92 μ A at full load dropping down to 1 μ A when the device is disabled. The device is optimized to be stable with a wide range of output capacitors including low ESR ceramic (10 μ F) or low capacitance (1 μ F) tantalum capacitors. The device has extremely low noise output performance (55 μ V_{rms}) without using any added filter capacitors. TPS779xx is designed to have a fast transient response for larger load current changes.

The TPS779xx is offered in 1.8-V, 2.5-V, and 3-V fixed-voltage versions and in an adjustable version (programmable over the range of 1.5 V to 5.5 V). Output voltage tolerance is 2% over line, load, and temperature ranges. The TPS779xx family is available in 8-pin MSOP (DGK) packages.

Because the PMOS device behaves as a low-value resistor, the dropout voltage is very low (typically 200 mV at an output current of 250 mA for 3.3 volt option) and is directly proportional to the output current. Additionally, since the PMOS pass element is a voltage-driven device, the quiescent current is very low and independent of output loading (typically 92 μ A over the full range of output current, 0 mA to 250 mA). These two key specifications yield a significant improvement in operating life for battery-powered systems.

TPS77930
DROPOUT VOLTAGE
vs
JUNCTION TEMPERATURE

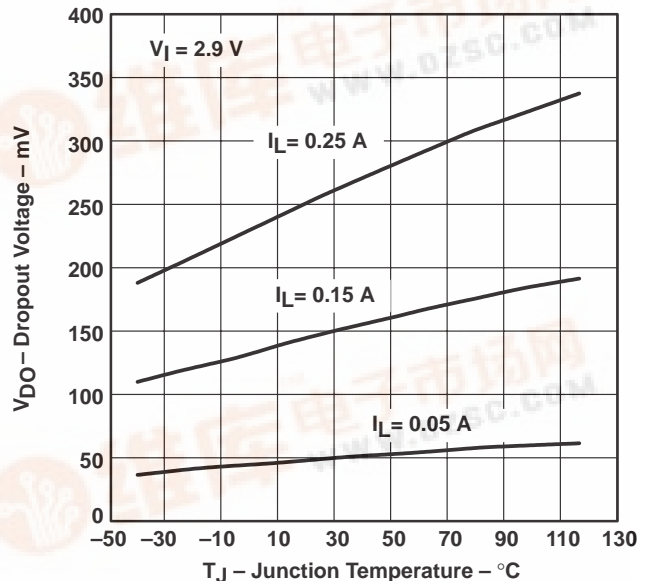

Please be aware that an important notice concerning availability, standard warranty, and use in critical applications of Texas Instruments semiconductor products and disclaimers thereto appears at the end of this data sheet.

TPS77901, TPS77918, TPS77925, TPS77930 250-mA LDO REGULATOR WITH INTEGRATED RESET IN A MSOP8 PACKAGE

SLVS283A – MARCH 2000 – REVISED MARCH 2000

description (continued)

The device is enabled when the EN pin is connected to a high-level input voltage. This LDO family also features a sleep mode; applying a TTL low signal to EN (enable) shuts down the regulator, reducing the quiescent current to less than 1 μA at $T_J = 25^\circ\text{C}$.

The TPS779xx features an integrated power-on reset, commonly used as a supply voltage supervisor (SVS), or reset output voltage. The RESET output of the TPS779xx initiates a reset in DSP, microcomputer or microprocessor systems at power-up and in the event of an undervoltage condition. An internal comparator in the TPS779xx monitors the output voltage of the regulator to detect an undervoltage condition on the regulated output voltage. When OUT reaches 95% of its regulated voltage, RESET will go to a high-impedance state after a 220 ms delay. RESET will go to low-impedance state when OUT is pulled below 95% (i.e. over load condition) of its regulated voltage.

AVAILABLE OPTIONS

T_J	OUTPUT VOLTAGE (V)	PACKAGED DEVICES
	TYP	MSOP (DGK)
-40°C to 125°C	3.0	TPS77930DGK
	2.5	TPS77925DGK
	1.8	TPS77918DGK
	Adjustable 1.5 V to 5.5 V	TPS77901DGK

The TPS77901 is programmable using an external resistor divider (see application information). The DGK package is available taped and reeled. Add an R suffix to the device type (e.g., TPS77901DGKR).

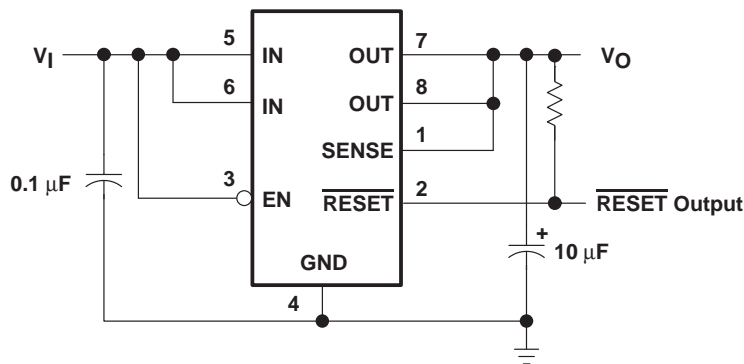
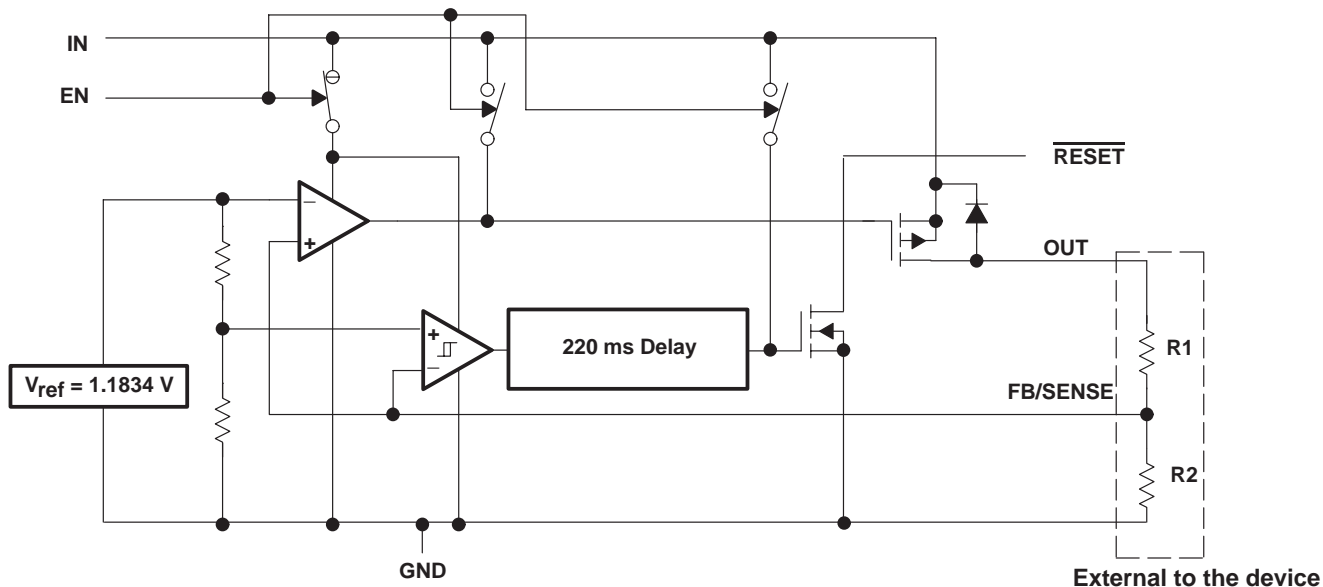

Figure 1. Typical Application Configuration (For Fixed Output Options)

TPS77901, TPS77918, TPS77925, TPS77930 250-mA LDO REGULATOR WITH INTEGRATED RESET IN A MSOP8 PACKAGE

SLVS283A – MARCH 2000 – REVISED MARCH 2000

functional block diagram—adjustable version



functional block diagram—fixed-voltage version

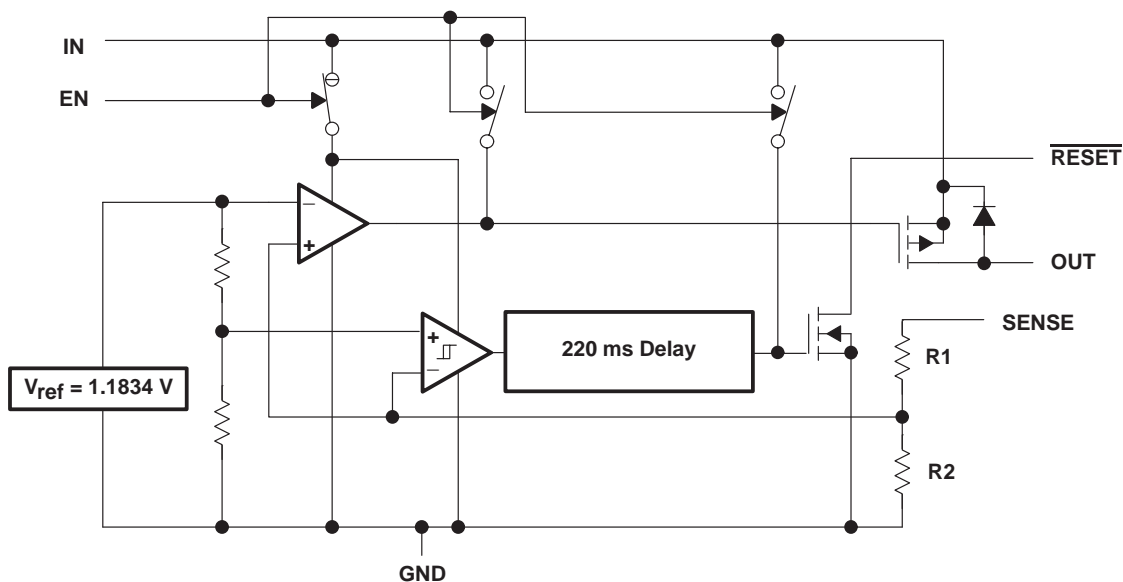

Terminal Functions (TPS779xx)

TERMINAL NAME	TERMINAL NO.	I/O	DESCRIPTION
FB/SENSE	1	I	Feedback input voltage for adjustable device (sense input for fixed options)
RESET	2	O	Reset output
EN	3	I	Enable input
GND	4		Regulator ground
IN	5, 6	I	Input voltage
OUT	7, 8	O	Regulated output voltage

TPS77901, TPS77918, TPS77925, TPS77930 250-mA LDO REGULATOR WITH INTEGRATED RESET IN A MSOP8 PACKAGE

SLVS283A – MARCH 2000 – REVISED MARCH 2000

TPS779xx $\overline{\text{RESET}}$ timing diagram

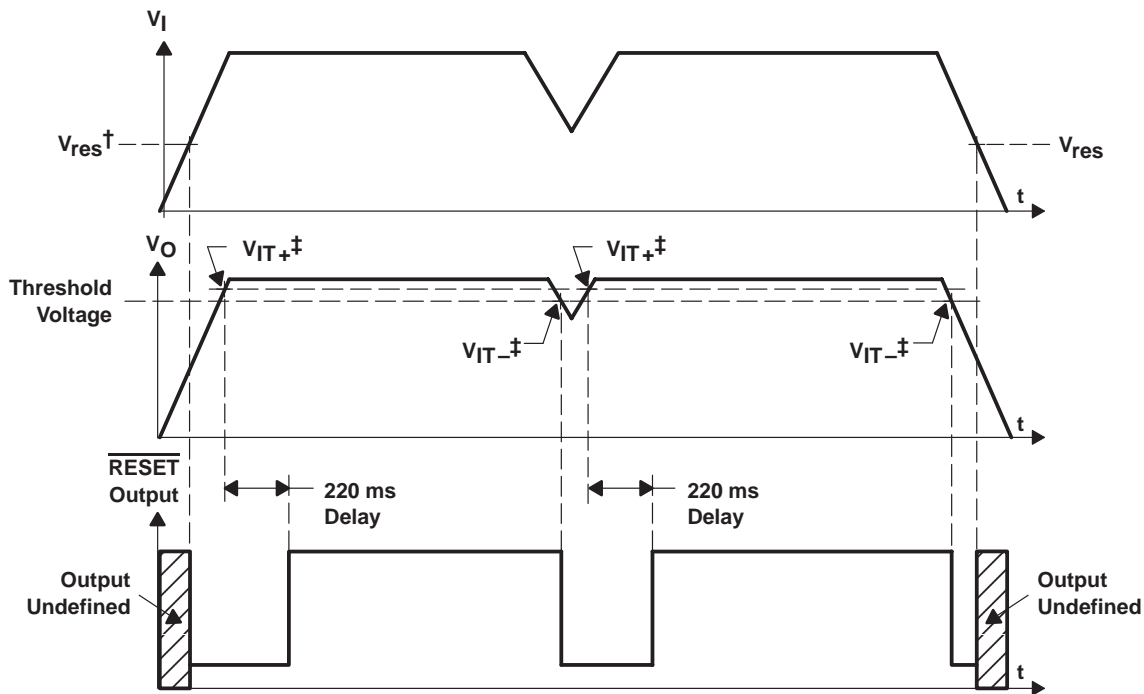

† V_{res} is the minimum input voltage for a valid $\overline{\text{RESET}}$. The symbol V_{res} is not currently listed within EIA or JEDEC standards for semiconductor symbology.

‡ V_{IT-} Trip voltage is typically 5% lower than the output voltage ($95\%V_O$). V_{IT-} to V_{IT+} is the hysteresis voltage.

TPS77901, TPS77918, TPS77925, TPS77930

250-mA LDO REGULATOR WITH INTEGRATED RESET IN A MSOP8 PACKAGE

SLVS283A – MARCH 2000 – REVISED MARCH 2000

absolute maximum ratings over operating junction temperature range (unless otherwise noted)[†]

Input voltage range [‡] , V_I	–0.3 V to 13.5 V
Voltage range at EN	–0.3 V to 16.5 V
Maximum $\overline{\text{RESET}}$ voltage	16.5 V
Peak output current	Internally limited
Continuous total power dissipation	See Dissipation Rating Table
Output voltage, V_O (OUT, FB)	5.5 V
Operating virtual junction temperature range, T_J	–40°C to 125°C
Storage temperature range, T_{stg}	–65°C to 150°C
ESD rating, HBM	2 kV

[†] Stresses beyond those listed under “absolute maximum ratings” may cause permanent damage to the device. These are stress ratings only, and functional operation of the device at these or any other conditions beyond those indicated under “recommended operating conditions” is not implied. Exposure to absolute-maximum-rated conditions for extended periods may affect device reliability.

[‡] All voltage values are with respect to network terminal ground.

DISSIPATION RATING TABLE – FREE-AIR TEMPERATURES

PACKAGE	AIR FLOW (CFM)	θ_{JA} (°C/W)	θ_{JC} (°C/W)	$T_A < 25^\circ\text{C}$ POWER RATING	DERATING FACTOR ABOVE $T_A = 25^\circ\text{C}$	$T_A = 70^\circ\text{C}$ POWER RATING	$T_A = 85^\circ\text{C}$ POWER RATING
DGK	0	266.2	3.84	376 mW	3.76 mW/°C	207 mW	150 mW
	150	255.2	3.92	392 mW	3.92 mW/°C	216 mW	157 mW
	250	242.8	4.21	412 mW	4.12 mW/°C	227 mW	165 mW

recommended operating conditions

	MIN	MAX	UNIT
Input voltage, V_I [§]	2.7	10	V
Output voltage range, V_O	1.5	5.5	V
Output current, I_O (see Note 1)	0	250	mA
Operating virtual junction temperature, T_J (see Note 1)	–40	125	°C

[§] To calculate the minimum input voltage for your maximum output current, use the following equation: $V_{I(\text{min})} = V_{O(\text{max})} + V_{\text{DO}(\text{max load})}$.

NOTE 1: Continuous current and operating junction temperature are limited by internal protection circuitry, but it is not recommended that the device operate under conditions beyond those specified in this table for extended periods of time.

TPS77901, TPS77918, TPS77925, TPS77930

250-mA LDO REGULATOR WITH INTEGRATED RESET IN A MSOP8 PACKAGE

SLVS283A – MARCH 2000 – REVISED MARCH 2000

electrical characteristics over recommended operating junction temperature range ($T_J = -40^\circ\text{C}$ to 125°C), $V_I = V_{O(\text{typ})} + 1\text{ V}$, $I_O = 1\text{ mA}$, $EN = 5\text{ V}$, $C_O = 10\text{ }\mu\text{F}$ (unless otherwise noted)

PARAMETER		TEST CONDITIONS	MIN	TYP	MAX	UNIT
Output voltage (see Notes 2 and 4)	Adjustable voltage	$1.5\text{ V} \leq V_O \leq 5.5\text{ V}$, $T_J = 25^\circ\text{C}$		V_O		V
		$1.5\text{ V} \leq V_O \leq 5.5\text{ V}$	$0.98V_O$		$1.02V_O$	
	1.8 V Output	$T_J = 25^\circ\text{C}$, $2.8\text{ V} < V_{IN} < 10\text{ V}$		1.8		
		$2.8\text{ V} < V_{IN} < 10\text{ V}$	1.764		1.836	
	2.5 V Output	$T_J = 25^\circ\text{C}$, $3.5\text{ V} < V_{IN} < 10\text{ V}$		2.5		
		$3.5\text{ V} < V_{IN} < 10\text{ V}$	2.45		2.55	
3.0 V Output	$T_J = 25^\circ\text{C}$, $4.0\text{ V} < V_{IN} < 10\text{ V}$		3.0			
	$4.0\text{ V} < V_{IN} < 10\text{ V}$	2.94		3.06		
Quiescent current (GND current) (see Notes 2 and 4)		$T_J = 25^\circ\text{C}$		92		μA
Output voltage line regulation ($\Delta V_O/V_O$) (see Note 3)		$V_O + 1\text{ V} < V_I \leq 10\text{ V}$, $T_J = 25^\circ\text{C}$		0.005		%/V
						0.05
Load regulation		$T_J = 25^\circ\text{C}$		1		mV
Output noise voltage		$\text{BW} = 300\text{ Hz to }100\text{ kHz}$, $T_J = 25^\circ\text{C}$, TPS77930		55		μVrms
Output current Limit		$V_O = 0\text{ V}$		0.9	1.3	A
Peak output current		2 ms pulse width, 50% duty cycle		400		mA
Thermal shutdown junction temperature				144		$^\circ\text{C}$
Standby current		$EN = V_I$, $T_J = 25^\circ\text{C}$			1	μA
						3
FB input current	Adjustable Voltage	$FB = 1.5\text{ V}$			1	μA
High level enable input voltage				2		V
Low level enable input voltage					0.7	V
Enable input current			-1		1	μA
Power supply ripple rejection (TPS77318, TPS77418)		$f = 1\text{ KHz}$, $T_J = 25^\circ\text{C}$		55		dB

NOTES: 2. Minimum input operating voltage is 2.7 V or $V_{O(\text{typ})} + 1\text{ V}$, whichever is greater. Maximum input voltage = 10 V, minimum output current 1 mA.

3. If $V_O < 1.8\text{ V}$ then $V_{\text{imax}} = 10\text{ V}$, $V_{\text{imin}} = 2.7\text{ V}$:

$$\text{Line Regulation (mV)} = (\%/V) \times \frac{V_O(V_{\text{imax}} - 2.7\text{ V})}{100} \times 1000$$

If $V_O > 2.5\text{ V}$ then $V_{\text{imax}} = 10\text{ V}$, $V_{\text{imin}} = V_O + 1\text{ V}$:

$$\text{Line Regulation (mV)} = (\%/V) \times \frac{V_O(V_{\text{imax}} - (V_O + 1))}{100} \times 1000$$

4. $I_O = 1\text{ mA}$ to 250 mA

TPS77901, TPS77918, TPS77925, TPS77930
250-mA LDO REGULATOR WITH INTEGRATED RESET IN A MSOP8 PACKAGE

SLVS283A – MARCH 2000 – REVISED MARCH 2000

electrical characteristics over recommended operating junction temperature range ($T_J = -40^\circ\text{C}$ to 125°C), $V_I = V_{O(\text{typ})} + 1\text{ V}$, $I_O = 1\text{ mA}$, $E_N = 5\text{ V}$, $C_O = 10\text{ }\mu\text{F}$ (unless otherwise noted) (continued)

PARAMETER		TEST CONDITIONS	MIN	TYP	MAX	UNIT
Reset	Minimum input voltage for valid $\overline{\text{RESET}}$	$I_{(\text{RESET})} = 300\text{ }\mu\text{A}$		1.1		V
	Trip threshold voltage	V_O decreasing	92		98	$\%V_O$
	Hysteresis voltage	Measured at V_O		0.5		$\%V_O$
	Output low voltage	$V_I = 2.7\text{ V}$, $I_{(\text{RESET})} = 1\text{ mA}$		0.15	0.4	V
	Leakage current	$V_{(\text{RESET})} = 5\text{ V}$			1	μA
	RESET time-out delay			220		ms
V_{DO}	Dropout voltage (see Note 5)	3 V Output		250		mV
					475	

NOTE 5: I_N voltage equals $V_O(\text{Typ}) - 100\text{ mV}$; 1.8 V, and 2.5 V dropout voltage limited by input voltage range limitations (i.e., 3.3 V input voltage needs to drop to 3.2 V for purpose of this test).

TYPICAL CHARACTERISTICS

Table of Graphs

		FIGURE	
V_O	Output voltage	vs Output current	2, 3
		vs Junction temperature	4, 5
	Ground current	vs Junction temperature	6
	Power supply rejection ratio	vs Frequency	7
	Output spectral noise density	vs Frequency	8
Z_O	Output impedance	vs Frequency	9
V_{DO}	Dropout voltage	vs Input voltage	10
		vs Junction temperature	11
	Line transient response		12, 14
	Load transient response		13, 15
	Output voltage	vs Time	16
	Equivalent series resistance (ESR)	vs Output current	18 – 21

TPS77901, TPS77918, TPS77925, TPS77930 250-mA LDO REGULATOR WITH INTEGRATED RESET IN A MSOP8 PACKAGE

SLVS283A – MARCH 2000 – REVISED MARCH 2000

TYPICAL CHARACTERISTICS

TPS77930
OUTPUT VOLTAGE
vs
OUTPUT CURRENT

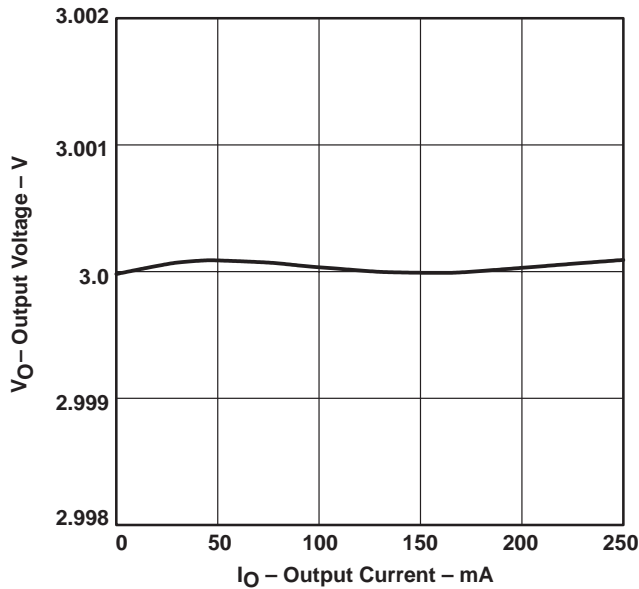

Figure 2

TPS77918
OUTPUT VOLTAGE
vs
OUTPUT CURRENT

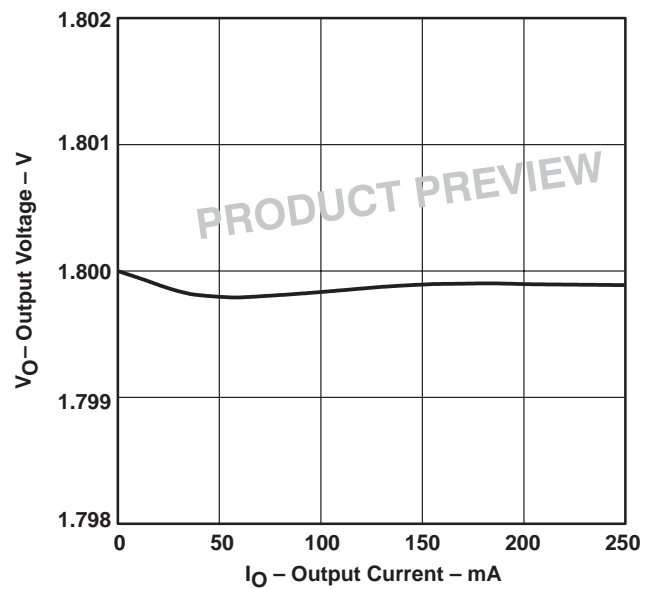

Figure 3

TPS77930
OUTPUT VOLTAGE
vs
JUNCTION TEMPERATURE

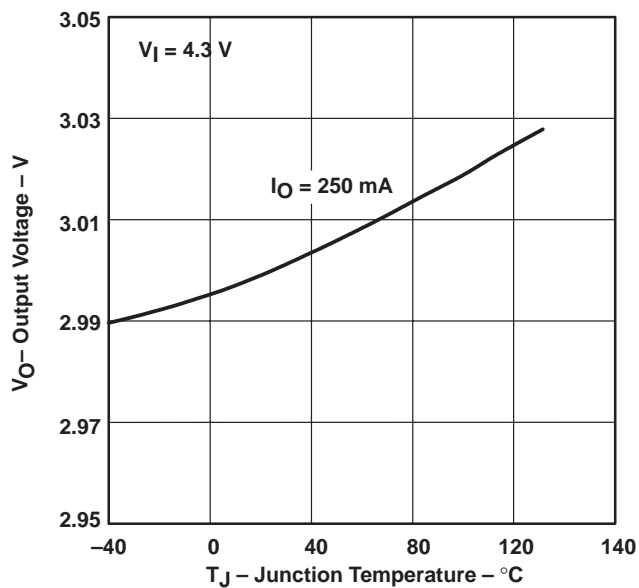

Figure 4

TPS77918
OUTPUT VOLTAGE
vs
JUNCTION TEMPERATURE

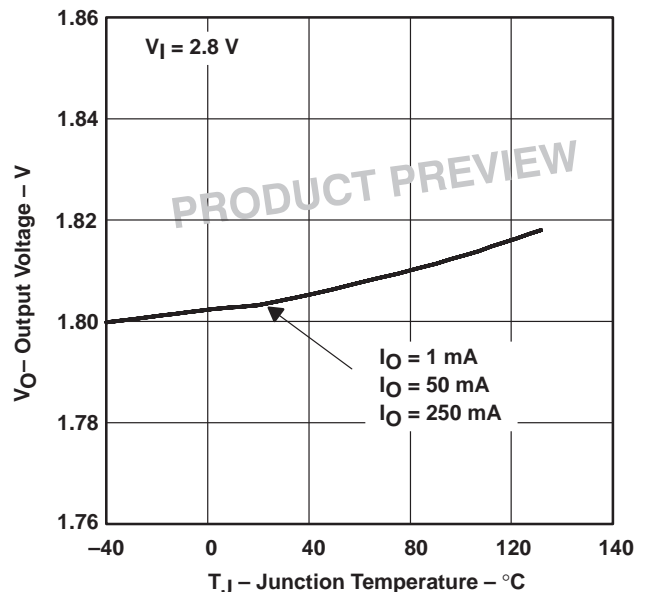

Figure 5

TPS77901, TPS77918, TPS77925, TPS77930 250-mA LDO REGULATOR WITH INTEGRATED RESET IN A MSOP8 PACKAGE

SLVS283A – MARCH 2000 – REVISED MARCH 2000

TYPICAL CHARACTERISTICS

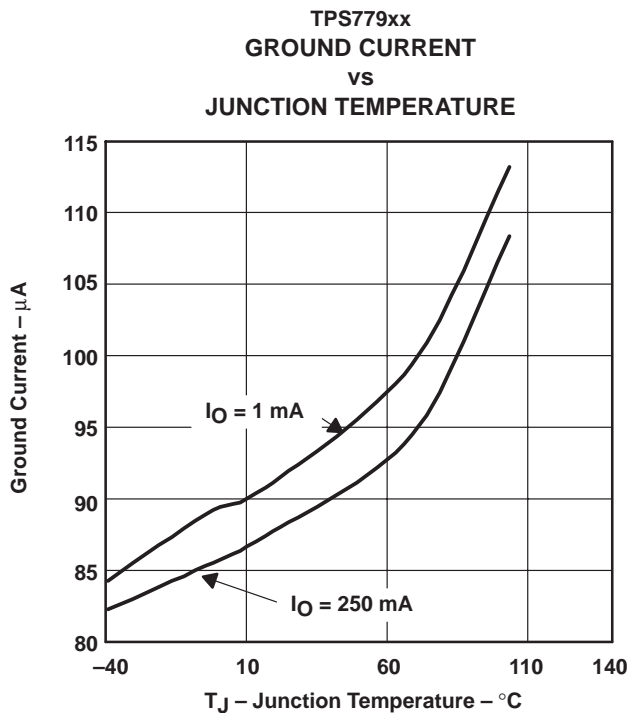

Figure 6

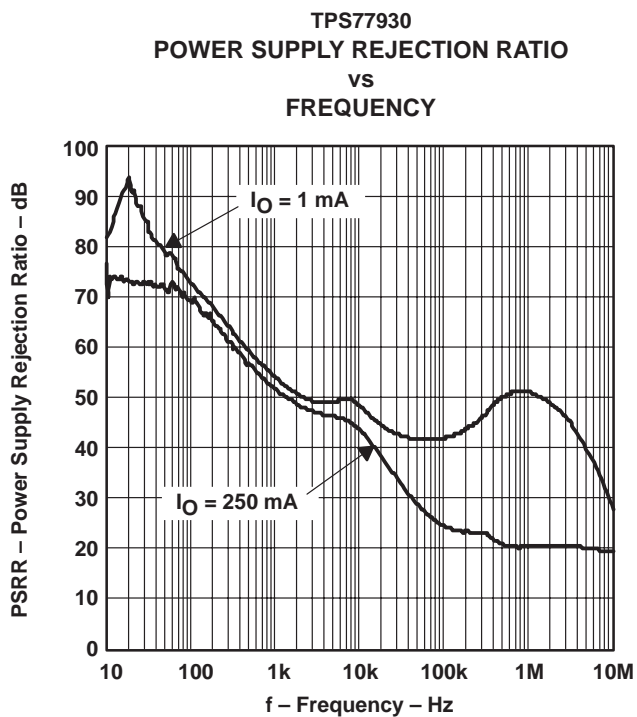

Figure 7

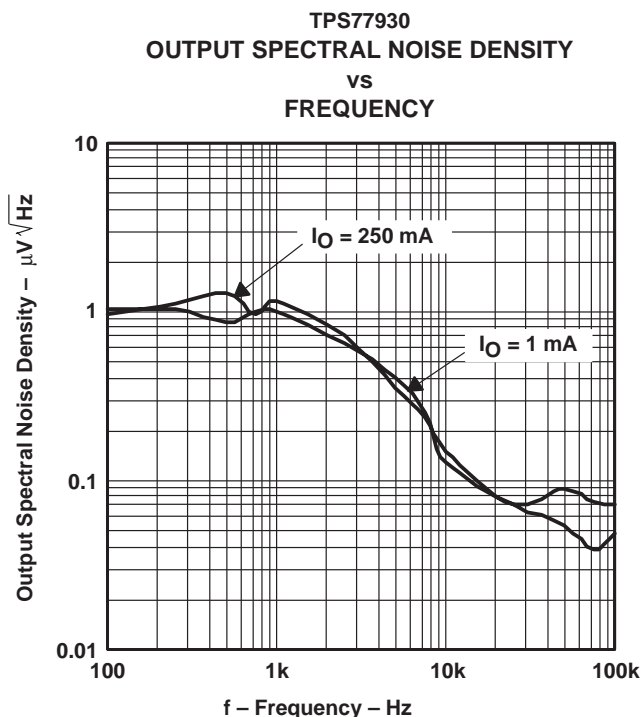

Figure 8

TPS77901, TPS77918, TPS77925, TPS77930 250-mA LDO REGULATOR WITH INTEGRATED RESET IN A MSOP8 PACKAGE

SLVS283A – MARCH 2000 – REVISED MARCH 2000

TYPICAL CHARACTERISTICS

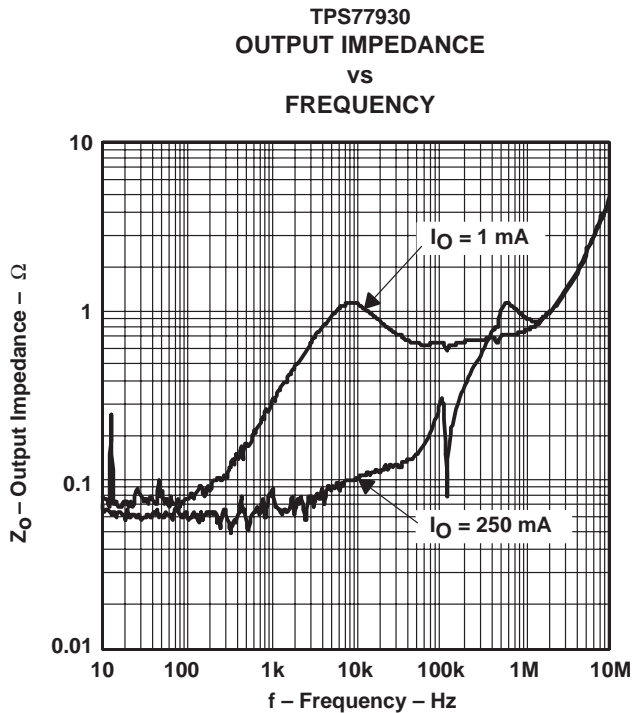

Figure 9

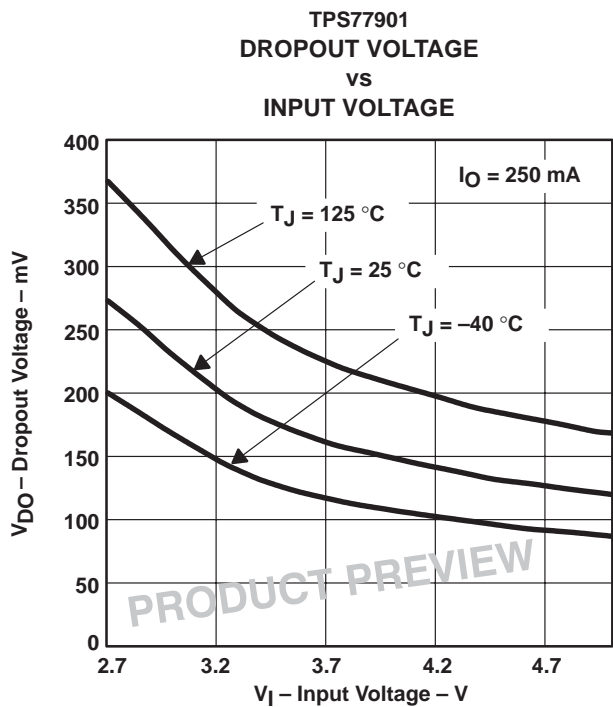

Figure 10

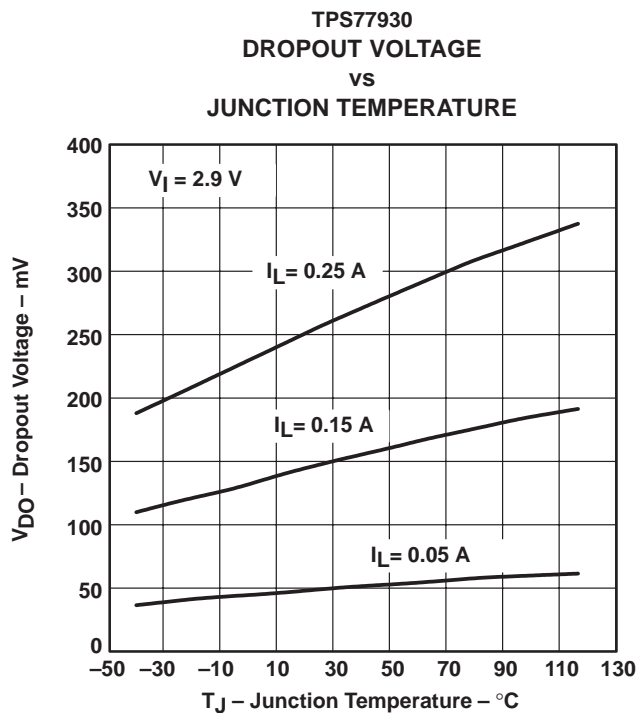

Figure 11

TPS77901, TPS77918, TPS77925, TPS77930 250-mA LDO REGULATOR WITH INTEGRATED RESET IN A MSOP8 PACKAGE

SLVS283A – MARCH 2000 – REVISED MARCH 2000

TYPICAL CHARACTERISTICS

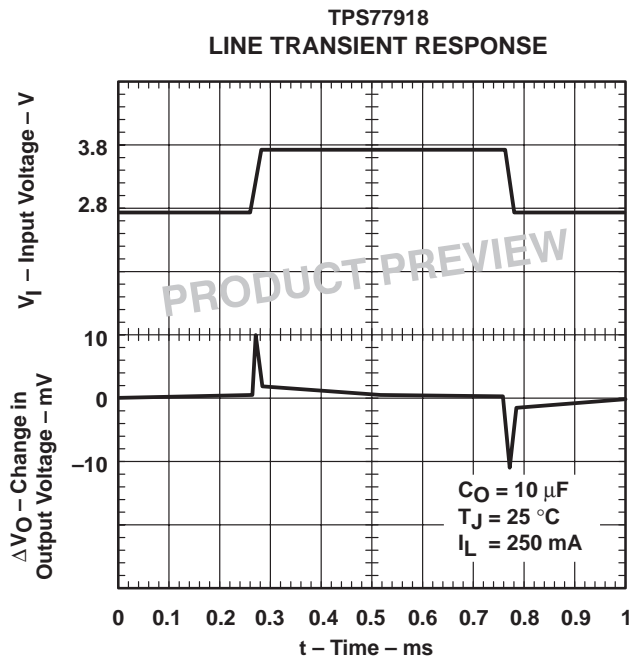

Figure 12

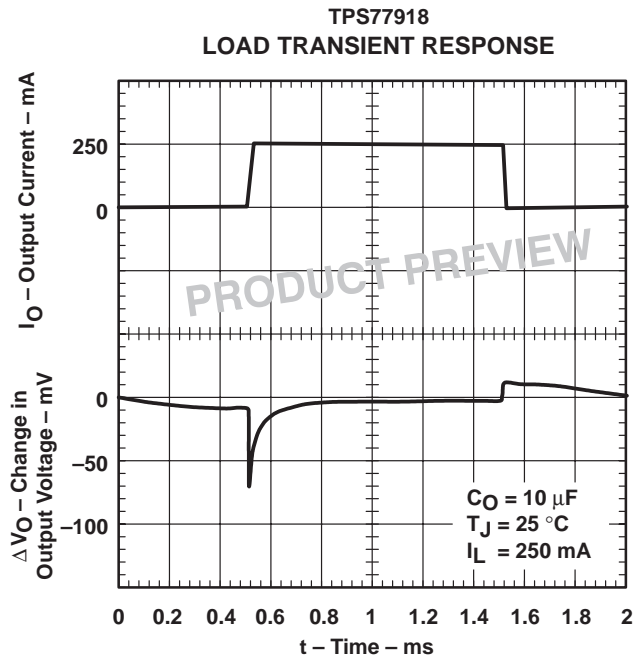

Figure 13

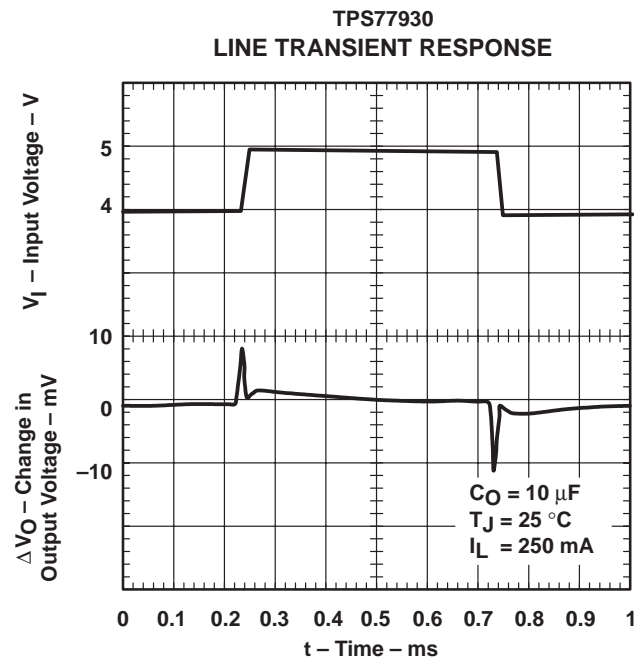

Figure 14

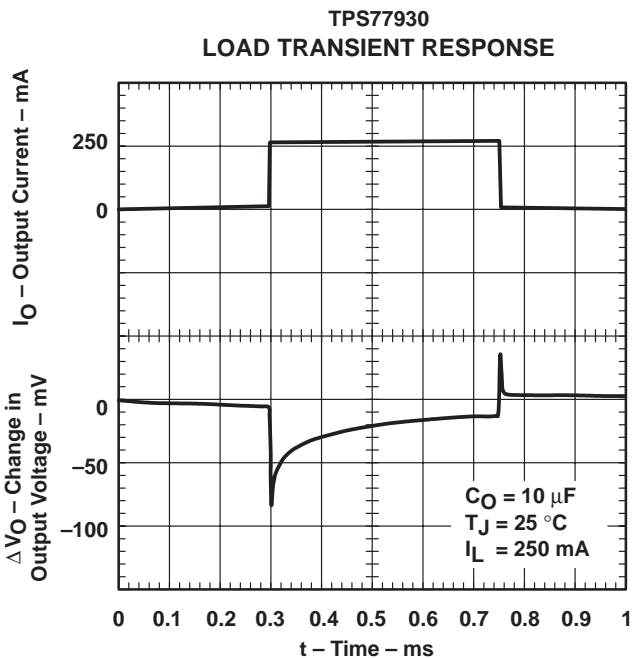

Figure 15

TPS77901, TPS77918, TPS77925, TPS77930
 250-mA LDO REGULATOR WITH INTEGRATED RESET IN A MSOP8 PACKAGE

SLVS283A – MARCH 2000 – REVISED MARCH 2000

TYPICAL CHARACTERISTICS

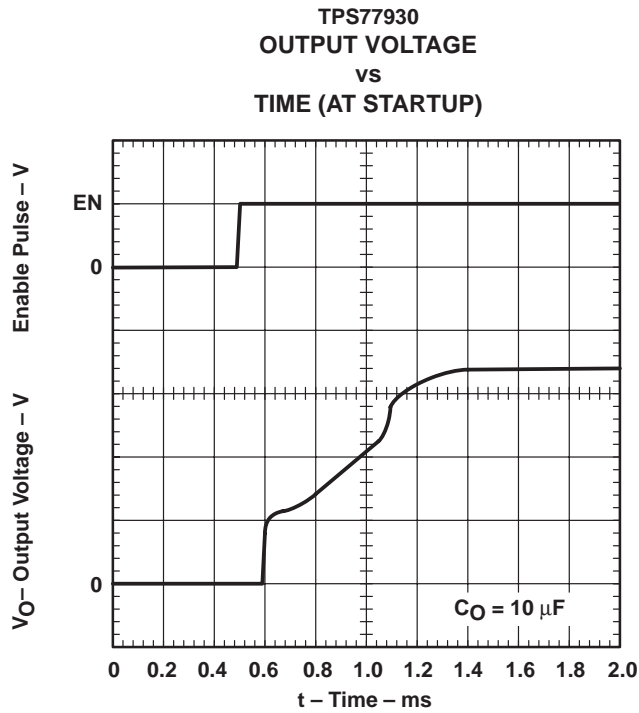

Figure 16

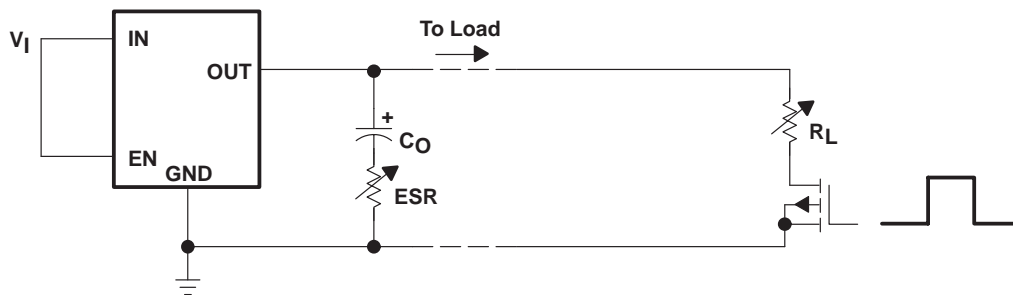
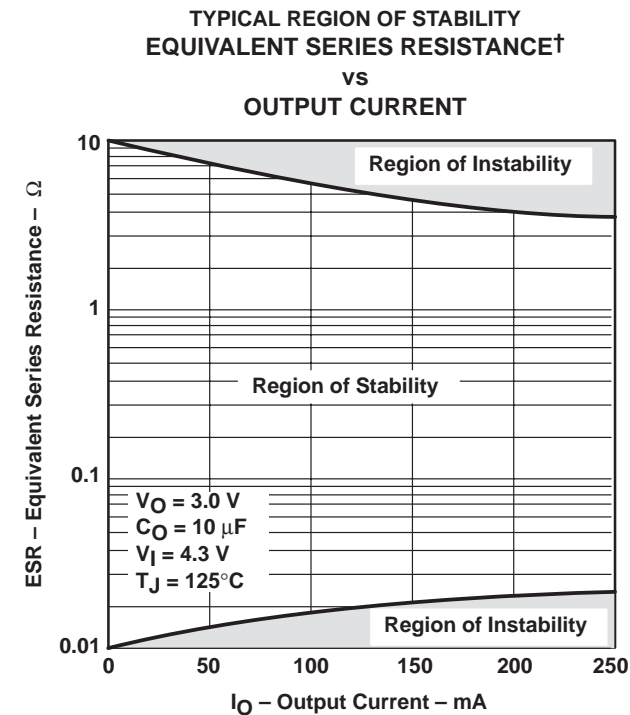
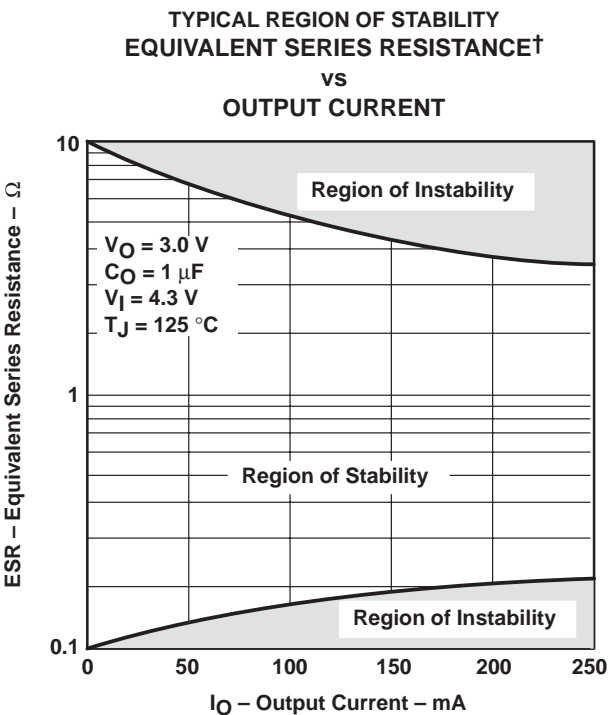
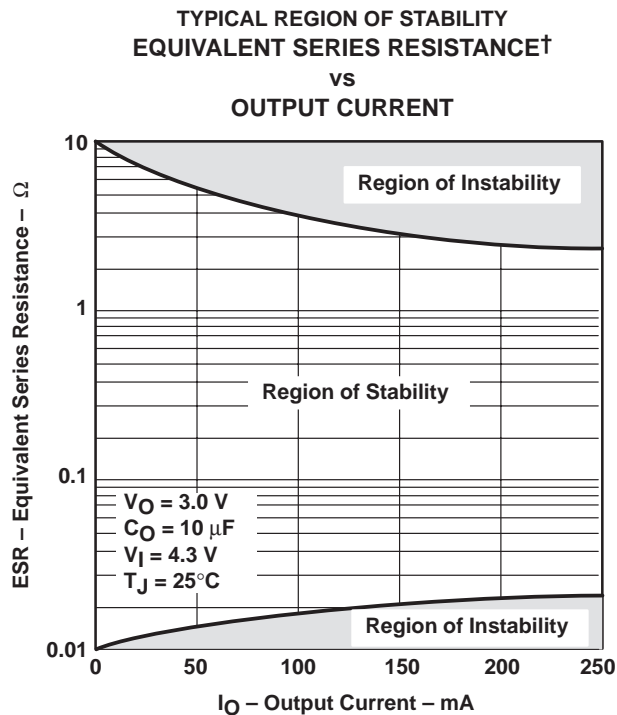
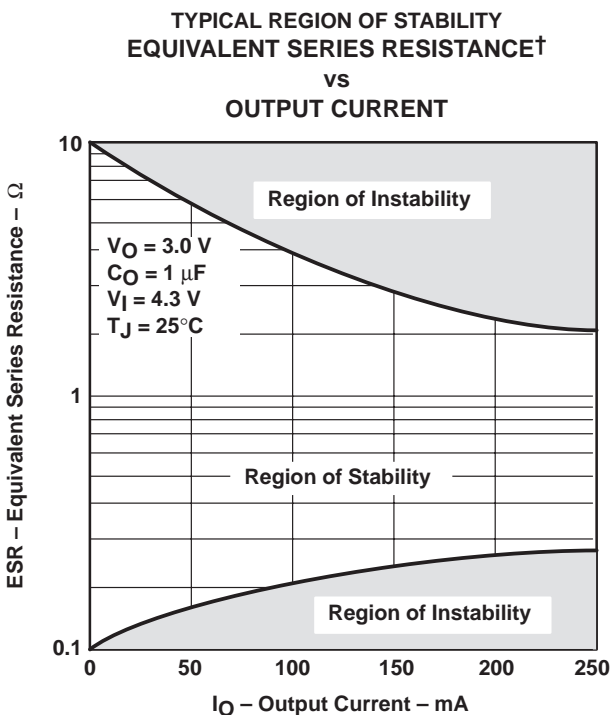

Figure 17. Test Circuit for Typical Regions of Stability (Figures 25 through 28) (Fixed Output Options)

TPS77901, TPS77918, TPS77925, TPS77930 250-mA LDO REGULATOR WITH INTEGRATED RESET IN A MSOP8 PACKAGE

SLVS283A – MARCH 2000 – REVISED MARCH 2000

TYPICAL CHARACTERISTICS



† Equivalent series resistance (ESR) refers to the total series resistance, including the ESR of the capacitor, any series resistance added externally, and PWB trace resistance to C_O .

TPS77901, TPS77918, TPS77925, TPS77930

250-mA LDO REGULATOR WITH INTEGRATED RESET IN A MSOP8 PACKAGE

SLVS283A – MARCH 2000 – REVISED MARCH 2000

APPLICATION INFORMATION

pin functions

enable (EN)

The EN terminal is an input which enables or shuts down the device. If EN is a logic low, the device will be in shutdown mode. When EN goes to logic high, then the device will be enabled.

sense (SENSE)

The SENSE terminal of the fixed-output options must be connected to the regulator output, and the connection should be as short as possible. Internally, SENSE connects to a high-impedance wide-bandwidth amplifier through a resistor-divider network and noise pickup feeds through to the regulator output. It is essential to route the SENSE connection in such a way to minimize/avoid noise pickup. Adding RC networks between the SENSE terminal and V_O to filter noise is not recommended because it can cause the regulator to oscillate.

feedback (FB)

FB is an input terminal used for the adjustable-output options and must be connected to an external feedback resistor divider. The FB connection should be as short as possible. It is essential to route it in such a way to minimize/avoid noise pickup. Adding RC networks between FB terminal and V_O to filter noise is not recommended because it can cause the regulator to oscillate.

reset ($\overline{\text{RESET}}$)

The $\overline{\text{RESET}}$ terminal is an open drain, active low output that indicates the status of V_O . When V_O reaches 95% of the regulated voltage, $\overline{\text{RESET}}$ will go to a low-impedance state after a 220-ms delay. $\overline{\text{RESET}}$ will go to a high-impedance state when V_{out} is below 95% of the regulated voltage. The open-drain output of the $\overline{\text{RESET}}$ terminal requires a pullup resistor.

external capacitor requirements

An input capacitor is not usually required; however, a bypass capacitor (0.047 μF or larger) improves load transient response and noise rejection if the TPS779xx is located more than a few inches from the power supply. A higher-capacitance capacitor may be necessary if large (hundreds of milliamps) load transients with fast rise times are anticipated.

Most low noise LDOs require an external capacitor to further reduce noise. This will impact the cost and board space. The TPS779xx has a very low noise specification requirement without using any external component.

Like all low dropout regulators, the TPS779xx requires an output capacitor connected between OUT (output of the LDO) and GND (signal ground) to stabilize the internal control loop. The minimum recommended capacitance value is 1 μF provided the ESR meets the requirement in Figures 19 and 21. In addition, a low-ESR capacitor can be used if the capacitance is at least 10 μF and the ESR meets the requirements in Figures 18 and 20. Solid tantalum electrolytic, aluminum electrolytic, and multilayer ceramic capacitors are all suitable, provided they meet the requirements described previously.

Ceramic capacitors have different types of dielectric material with each exhibiting different temperature and voltage variation. The most common types are X5R, X7R, Y5U, Z5U, and NPO. The NPO type ceramic type capacitors are generally the most stable over temperature. However, the X5R and X7R are also relatively stable over temperature (with the X7R being the more stable of the two) and are therefore acceptable to use. The Y5U and Z5U types provide high capacitance in a small geometry, but exhibit large variations over temperature; therefore, the Y5U and Z5U are not generally recommended for use on this LDO. Independent of which type of capacitor is used, one must make certain that at the worst case condition the capacitance/ESR meets the requirement specified in Figures 18 – 21.

APPLICATION INFORMATION

Figure 22 shows the output capacitor and its parasitic impedances in a typical LDO output stage.

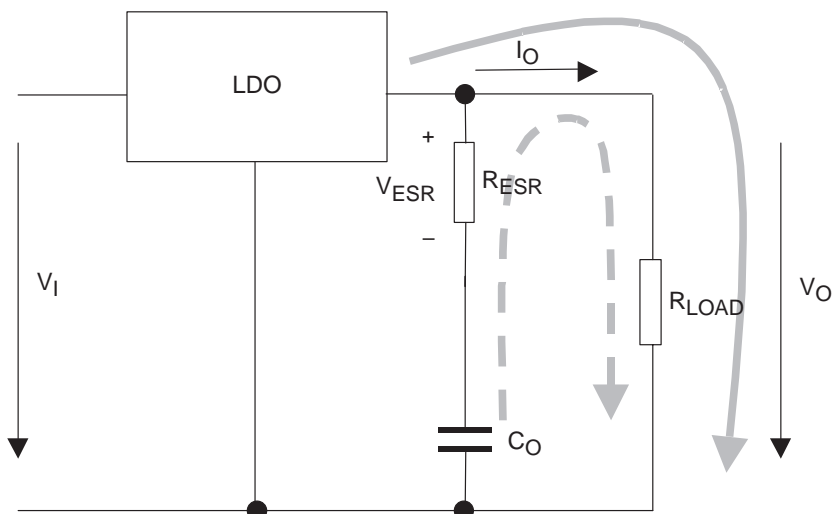

Figure 22. – LDO Output Stage With Parasitic Resistances ESR and ESL

In steady state (dc state condition), the load current is supplied by the LDO (solid arrow) and the voltage across the capacitor is the same as the output voltage ($V(C_O) = V_O$). This means no current is flowing into the C_O branch. If I_O suddenly increases (transient condition), the following occurs;

The LDO is not able to supply the sudden current need due to its response time (t_1 in Figure 23). Therefore, capacitor C_O provides the current for the new load condition (dashed arrow). C_O now acts like a battery with an internal resistance, ESR. Depending on the current demand at the output, a voltage drop will occur at R_{ESR} . This voltage is shown as V_{ESR} in Figure 22.

When C_O is conducting current to the load, initial voltage at the load will be $V_O = V(C_O) - V_{ESR}$. Due to the discharge of C_O , the output voltage V_O will drop continuously until the response time t_1 of the LDO is reached and the LDO will resume supplying the load. From this point, the output voltage starts rising again until it reaches the regulated voltage. This period is shown as t_2 in Figure 23.

The figure also shows the impact of different ESRs on the output voltage. The left brackets show different levels of ESRs where number 1 displays the lowest and number 3 displays the highest ESR.

From above, the following conclusions can be drawn:

- The higher the ESR, the larger the droop at the beginning of load transient.
- The smaller the output capacitor, the faster the discharge time and the bigger the voltage droop during the LDO response period.

TPS77901, TPS77918, TPS77925, TPS77930 250-mA LDO REGULATOR WITH INTEGRATED RESET IN A MSOP8 PACKAGE

SLVS283A – MARCH 2000 – REVISED MARCH 2000

APPLICATION INFORMATION

conclusion

To minimize the transient output droop, capacitors must have a low ESR and be large enough to support the minimum output voltage requirement.

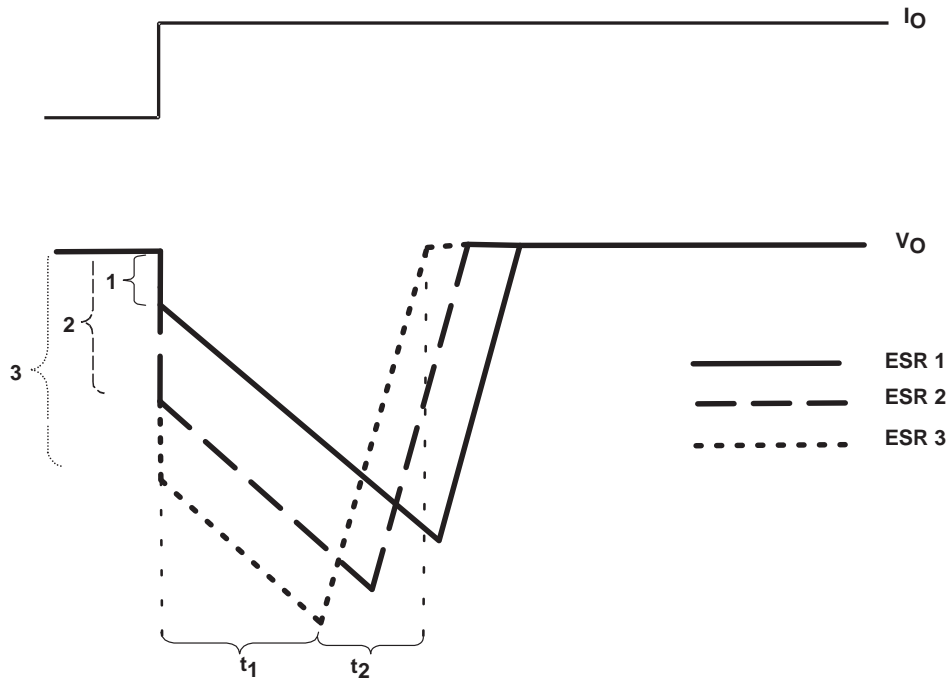

Figure 23. – Correlation of Different ESRs and Their Influence to the Regulation of V_O at a Load Step From Low-to-High Output Current

TPS77901, TPS77918, TPS77925, TPS77930 250-mA LDO REGULATOR WITH INTEGRATED RESET IN A MSOP8 PACKAGE

SLVS283A – MARCH 2000 – REVISED MARCH 2000

APPLICATION INFORMATION

programming the TPS77901 adjustable LDO regulator

The output voltage of the TPS77901 adjustable regulator is programmed using an external resistor divider as shown in Figure 24. The output voltage is calculated using:

$$V_O = V_{ref} \times \left(1 + \frac{R1}{R2}\right) \quad (1)$$

Where:

$$V_{ref} = 1.1834 \text{ V typ (the internal reference voltage)}$$

Resistors R1 and R2 should be chosen for approximately 7- μ A divider current. Lower value resistors can be used but offer no inherent advantage and waste more power. Higher values should be avoided as leakage currents at FB increase the output voltage error. The recommended design procedure is to choose R2 = 30.1 k Ω to set the divider current at 7 μ A and then calculate R1 using:

$$R1 = \left(\frac{V_O}{V_{ref}} - 1\right) \times R2 \quad (2)$$

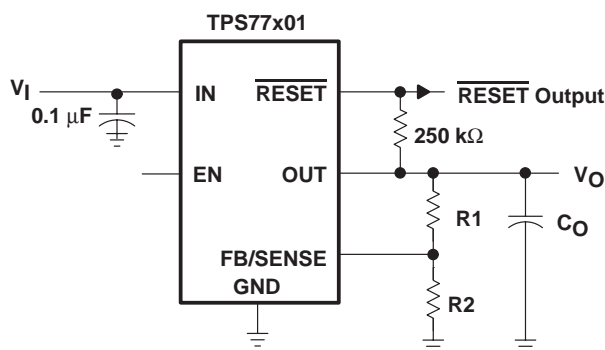

**OUTPUT VOLTAGE
PROGRAMMING GUIDE**

OUTPUT VOLTAGE	R1	R2	UNIT
2.5 V	174	169	k Ω
3.3 V	287	169	k Ω
3.6 V	324	169	k Ω

NOTE: To reduce noise and prevent oscillation, R1 and R2 need to be as close as possible to the FB/SENSE terminal.

Figure 24. TPS77901 Adjustable LDO Regulator Programming

regulator protection

The TPS779xx PMOS-pass transistor has a built-in back diode that conducts reverse currents when the input voltage drops below the output voltage (e.g., during power down). Current is conducted from the output to the input and is not internally limited. When extended reverse voltage is anticipated, external limiting may be appropriate.

The TPS779xx also features internal current limiting and thermal protection. During normal operation, the TPS779xx limits output current to approximately 0.9 A. When current limiting engages, the output voltage scales back linearly until the overcurrent condition ends. While current limiting is designed to prevent gross device failure, care should be taken not to exceed the power dissipation ratings of the package. If the temperature of the device exceeds 150°C(typ), thermal-protection circuitry shuts it down. Once the device has cooled below 130°C(typ), regulator operation resumes.

TPS77901, TPS77918, TPS77925, TPS77930 250-mA LDO REGULATOR WITH INTEGRATED RESET IN A MSOP8 PACKAGE

SLVS283A – MARCH 2000 – REVISED MARCH 2000

APPLICATION INFORMATION

power dissipation and junction temperature

Specified regulator operation is assured to a junction temperature of 125°C; the maximum junction temperature should be restricted to 125°C under normal operating conditions. This restriction limits the power dissipation the regulator can handle in any given application. To ensure the junction temperature is within acceptable limits, calculate the maximum allowable dissipation, $P_{D(max)}$, and the actual dissipation, P_D , which must be less than or equal to $P_{D(max)}$.

The maximum-power-dissipation limit is determined using the following equation:

$$P_{D(max)} = \frac{T_{Jmax} - T_A}{R_{\theta JA}}$$

Where:

T_{Jmax} is the maximum allowable junction temperature

$R_{\theta JA}$ is the thermal resistance junction-to-ambient for the package, i.e., 266.2°C/W for the 8-terminal MSOP with no airflow.

T_A is the ambient temperature.

The regulator dissipation is calculated using:

$$P_D = (V_I - V_O) \times I_O$$

Power dissipation resulting from quiescent current is negligible. Excessive power dissipation will trigger the thermal protection circuit.

TPS77901, TPS77918, TPS77925, TPS77930
 250-mA LDO REGULATOR WITH INTEGRATED RESET IN A MSOP8 PACKAGE

SLVS283A – MARCH 2000 – REVISED MARCH 2000

MECHANICAL DATA

DGK (R-PDSO-G8)

PLASTIC SMALL-OUTLINE PACKAGE

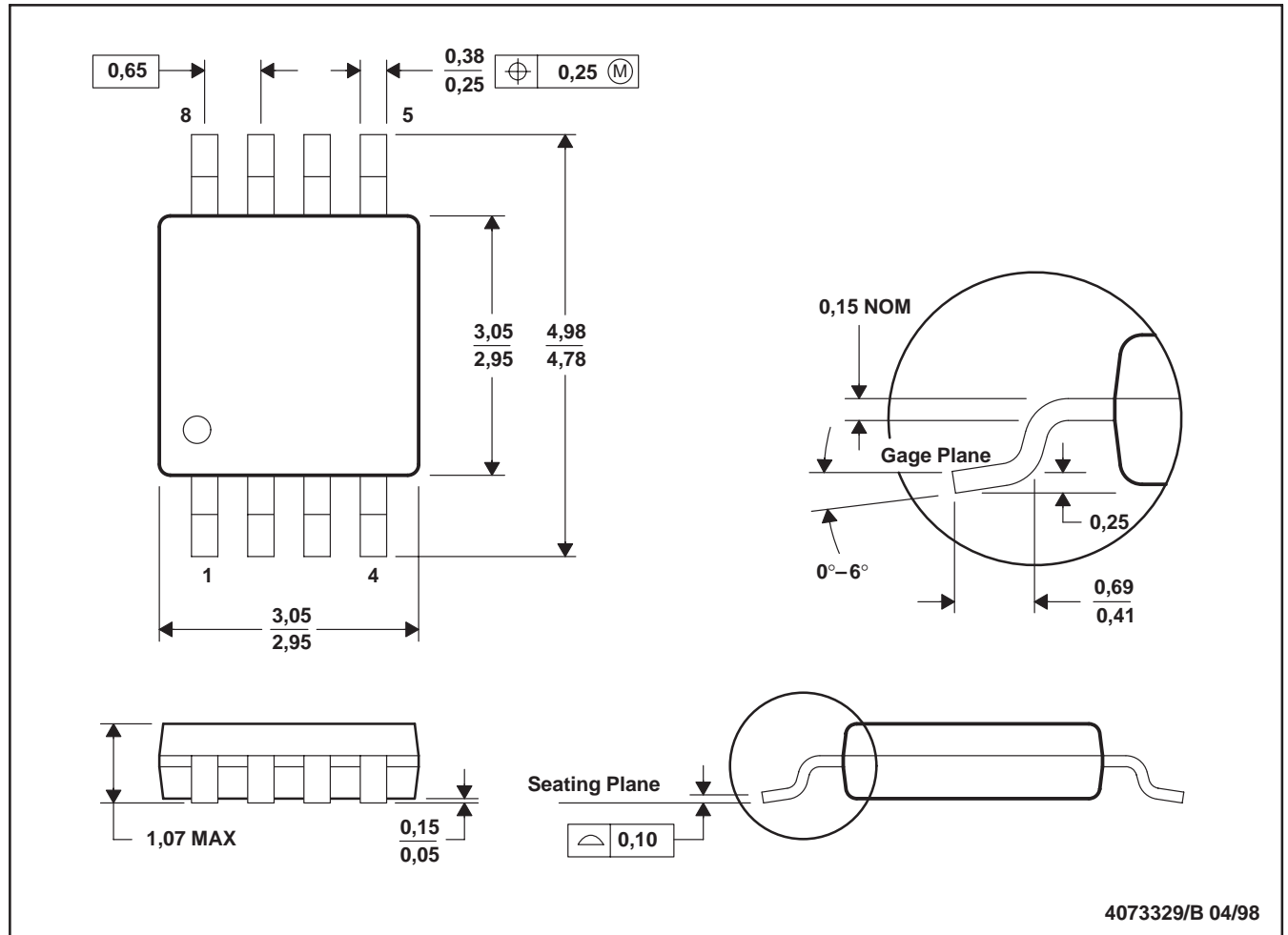

4073329/B 04/98

- NOTES: A. All linear dimensions are in millimeters.
 B. This drawing is subject to change without notice.
 C. Body dimensions do not include mold flash or protrusion.
 D. Falls within JEDEC MO-187

IMPORTANT NOTICE

Texas Instruments and its subsidiaries (TI) reserve the right to make changes to their products or to discontinue any product or service without notice, and advise customers to obtain the latest version of relevant information to verify, before placing orders, that information being relied on is current and complete. All products are sold subject to the terms and conditions of sale supplied at the time of order acknowledgment, including those pertaining to warranty, patent infringement, and limitation of liability.

TI warrants performance of its semiconductor products to the specifications applicable at the time of sale in accordance with TI's standard warranty. Testing and other quality control techniques are utilized to the extent TI deems necessary to support this warranty. Specific testing of all parameters of each device is not necessarily performed, except those mandated by government requirements.

Of course, customers are responsible for their applications using TI components.

In order to minimize risks associated with the customer's applications, adequate design and operating safeguards must be provided by the customer to minimize inherent or procedural hazards.

TI assumes no liability for applications assistance or customer product design. TI does not warrant or represent that any license, either express or implied, is granted under any patent right, copyright, mask work right, or other intellectual property right of TI covering or relating to any combination, machine, or process in which such semiconductor products or services might be or are used. TI's publication of information regarding any third party's products or services does not constitute TI's approval, warranty or endorsement thereof.