

DATA SHEET

74LV377

Octal D-type flip-flop with data enable;
positive edge-trigger

Product specification
Supersedes data of 1997 Mar 04
IC24 Data Handbook

1998 Jun 10



Octal D-type flip-flop with data enable; positive edge-trigger

74LV377

FEATURES

- Optimized for Low Voltage applications: 1.0 to 3.6V
- Accepts TTL input levels between $V_{CC} = 2.7V$ and $V_{CC} = 3.6V$
- Typical V_{OLP} (output ground bounce) $< 0.8V$ @ $V_{CC} = 3.3V$, $T_{amb} = 25^{\circ}C$
- Typical V_{OHV} (output V_{OH} undershoot) $> 2V$ @ $V_{CC} = 3.3V$, $T_{amb} = 25^{\circ}C$
- Ideal for addressable register applications
- Data enable for address and data synchronization applications
- Eight positive-edge triggered D-type flip-flops
- Output capability: standard
- I_{CC} category: MSI

DESCRIPTION

The 74LV377 is a low-voltage CMOS device and is pin and function compatible with 74HC/HCT377.

The 74LV377 has eight edge-triggered, D-type flip-flops with individual D inputs and Q outputs. A common clock (CP) input loads all flip-flops simultaneously when the data enable (\bar{E}) is LOW. The state of each D input, one set-up time before the LOW-to-HIGH clock transition, is transferred to the corresponding output (Q_n) of the flip-flop. The \bar{E} input must be stable only one set-up time prior to the LOW-to-HIGH transition for predictable operation.

QUICK REFERENCE DATA

GND = 0V; $T_{amb} = 25^{\circ}C$; $t_r = t_f \leq 2.5$ ns

SYMBOL	PARAMETER	CONDITIONS	TYPICAL	UNIT
t_{PHL}/t_{PLH}	Propagation delay CP to Q_n	$C_L = 15pF$ $V_{CC} = 3.3V$	13	ns
f_{max}	Maximum clock frequency		77	MHz
C_I	Input capacitance		3.5	pF
C_{PD}	Power dissipation capacitance per flip-flop	Notes 1 and 2	20	pF

NOTES:

1. C_{PD} is used to determine the dynamic power dissipation (P_D in μW)
 $P_D = C_{PD} \times V_{CC}^2 \times f_i + \sum (C_L \times V_{CC}^2 \times f_o)$ where:
 f_i = input frequency in MHz; C_L = output load capacity in pF;
 f_o = output frequency in MHz; V_{CC} = supply voltage in V;
 $\sum (C_L \times V_{CC}^2 \times f_o)$ = sum of the outputs.
2. The condition is $V_I = GND$ to V_{CC}

ORDERING INFORMATION

PACKAGES	TEMPERATURE RANGE	OUTSIDE NORTH AMERICA	NORTH AMERICA	PKG. DWG. #
20-Pin Plastic DIL	-40°C to +125°C	74LV377 N	74LV377 N	SOT146-1
20-Pin Plastic SO	-40°C to +125°C	74LV377 D	74LV377 D	SOT163-1
20-Pin Plastic SSOP Type II	-40°C to +125°C	74LV377 DB	74LV377 DB	SOT339-1
20-Pin Plastic TSSOP Type I	-40°C to +125°C	74LV377 PW	74LV377PW DH	SOT360-1

PIN DESCRIPTION

PIN NUMBER	SYMBOL	FUNCTION
1	\bar{E}	Data enable input (active-LOW)
2, 5, 6, 9, 12, 15, 16, 19	Q_0 to Q_7	flip-flop outputs
3, 4, 7, 8, 13, 14, 17, 18	D_0 to D_7	Data inputs
10	GND	Ground (0V)
11	CP	Clock input (LOW-to-HIGH, edge-triggered)
20	V_{CC}	Positive supply voltage

FUNCTION TABLE

OPERATING MODES	INPUTS			OUTPUTS
	CP	\bar{E}	D_n	Q_n
Load "1"	↑	l	h	H
Load "0"	↑	l	l	L
Hold (do nothing)	↑ X	h H	X X	No change No change

- H = HIGH voltage level
h = HIGH voltage level one set-up time prior to the LOW-to-HIGH CP transition
L = LOW voltage level
l = LOW voltage level one set-up time prior to the LOW-to-HIGH CP transition
↑ = LOW-to-HIGH CP transition
X = Don't care

Octal D-type flip-flop with data enable; positive edge-trigger

74LV377

PIN CONFIGURATION

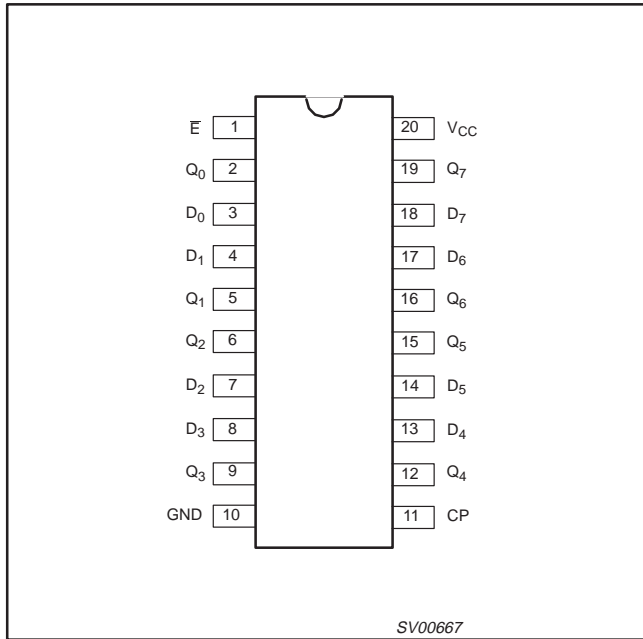

LOGIC SYMBOL (IEEE/IEC)

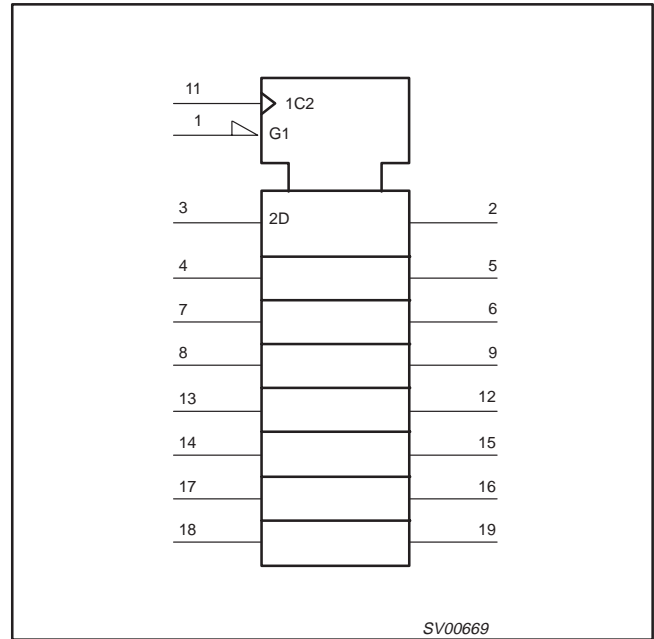

LOGIC SYMBOL

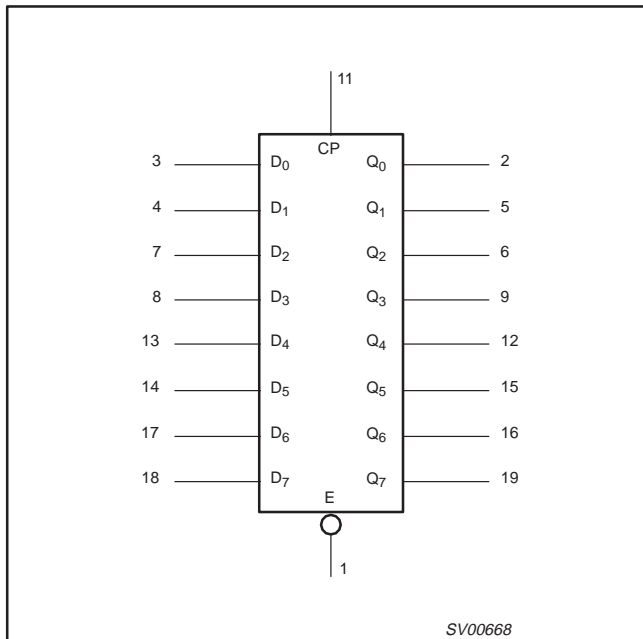

FUNCTIONAL DIAGRAM

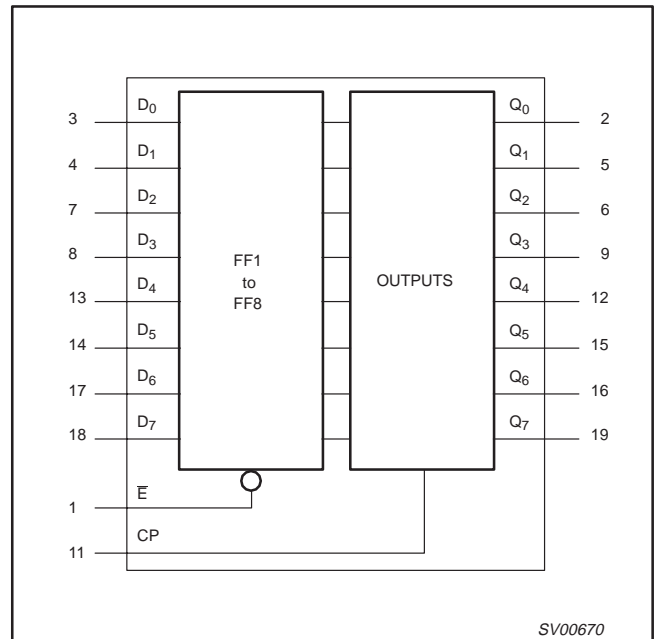

Octal D-type flip-flop with data enable; positive edge-trigger

74LV377

RECOMMENDED OPERATING CONDITIONS

SYMBOL	PARAMETER	CONDITIONS	MIN	TYP	MAX	UNIT
V_{CC}	DC supply voltage	See Note 1	1.0	3.3	3.6	V
V_I	Input voltage		0	–	V_{CC}	V
V_O	Output voltage		0	–	V_{CC}	V
T_{amb}	Operating ambient temperature range in free air	See DC and AC characteristics	–40 –40		+85 +125	°C
t_r, t_f	Input rise and fall times	$V_{CC} = 1.0V$ to $2.0V$ $V_{CC} = 2.0V$ to $2.7V$ $V_{CC} = 2.7V$ to $3.6V$	– – –	– – –	500 200 100	ns/V

NOTE:

- The LV is guaranteed to function down to $V_{CC} = 1.0V$ (input levels GND or V_{CC}); DC characteristics are guaranteed from $V_{CC} = 1.2V$ to $V_{CC} = 3.6V$.

ABSOLUTE MAXIMUM RATINGS^{1, 2}

In accordance with the Absolute Maximum Rating System (IEC 134).
Voltages are referenced to GND (ground = 0V).

SYMBOL	PARAMETER	CONDITIONS	RATING	UNIT
V_{CC}	DC supply voltage		–0.5 to +4.6	V
$\pm I_{IK}$	DC input diode current	$V_I < -0.5$ or $V_I > V_{CC} + 0.5V$	20	mA
$\pm I_{OK}$	DC output diode current	$V_O < -0.5$ or $V_O > V_{CC} + 0.5V$	50	mA
$\pm I_O$	DC output source or sink current – standard outputs	$-0.5V < V_O < V_{CC} + 0.5V$	25	mA
$\pm I_{GND},$ $\pm I_{CC}$	DC V_{CC} or GND current for types with –standard outputs		50	mA
T_{stg}	Storage temperature range		–65 to +150	°C
P_{tot}	Power dissipation per package –plastic DIL –plastic mini-pack (SO) –plastic shrink mini-pack (SSOP and TSSOP)	for temperature range: –40 to +125°C above +70°C derate linearly with 12mW/K above +70°C derate linearly with 8 mW/K above +60°C derate linearly with 5.5 mW/K	750 500 400	mW

NOTES:

- Stresses beyond those listed may cause permanent damage to the device. These are stress ratings only and functional operation of the device at these or any other conditions beyond those indicated under “recommended operating conditions” is not implied. Exposure to absolute-maximum-rated conditions for extended periods may affect device reliability.
- The input and output voltage ratings may be exceeded if the input and output current ratings are observed.

Octal D-type flip-flop with data enable; positive edge-trigger

74LV377

DC CHARACTERISTICS FOR THE LV FAMILY

Over recommended operating conditions. Voltages are referenced to GND (ground = 0V).

SYMBOL	PARAMETER	TEST CONDITIONS	LIMITS					UNIT
			-40°C to +85°C			-40°C to +125°C		
			MIN	TYP ¹	MAX	MIN	MAX	
V _{IH}	HIGH level Input voltage	V _{CC} = 1.2V	0.9			0.9		V
		V _{CC} = 2.0V	1.4			1.4		
		V _{CC} = 2.7 to 3.6V	2.0			2.0		
V _{IL}	LOW level Input voltage	V _{CC} = 1.2V			0.3		0.3	V
		V _{CC} = 2.0V			0.6		0.6	
		V _{CC} = 2.7 to 3.6V			0.8		0.8	
V _{OH}	HIGH level output voltage; all outputs	V _{CC} = 1.2V; V _I = V _{IH} or V _{IL} ; -I _O = 100µA		1.2				V
		V _{CC} = 2.0V; V _I = V _{IH} or V _{IL} ; -I _O = 100µA	1.8	2.0		1.8		
		V _{CC} = 2.7V; V _I = V _{IH} or V _{IL} ; -I _O = 100µA	2.5	2.7		2.5		
		V _{CC} = 3.0V; V _I = V _{IH} or V _{IL} ; -I _O = 100µA	2.8	3.0		2.8		
	HIGH level output voltage; STANDARD outputs	V _{CC} = 3.0V; V _I = V _{IH} or V _{IL} ; -I _O = 6mA	2.40	2.82		2.20		
V _{OL}	LOW level output voltage; all outputs	V _{CC} = 1.2V; V _I = V _{IH} or V _{IL} ; I _O = 100µA		0				V
		V _{CC} = 2.0V; V _I = V _{IH} or V _{IL} ; I _O = 100µA		0	0.2		0.2	
		V _{CC} = 2.7V; V _I = V _{IH} or V _{IL} ; I _O = 100µA		0	0.2		0.2	
		V _{CC} = 3.0V; V _I = V _{IH} or V _{IL} ; I _O = 100µA		0	0.2		0.2	
	LOW level output voltage; STANDARD outputs	V _{CC} = 3.0V; V _I = V _{IH} or V _{IL} ; I _O = 6mA		0.25	0.40		0.50	
I _I	Input leakage current	V _{CC} = 3.6V; V _I = V _{CC} or GND			1.0		1.0	µA
I _{CC}	Quiescent supply current; MSI	V _{CC} = 3.6V; V _I = V _{CC} or GND; I _O = 0			20.0		160	µA
ΔI _{CC}	Additional quiescent supply current per input	V _{CC} = 2.7V to 3.6V; V _I = V _{CC} - 0.6V			500		850	µA

NOTE:

1. All typical values are measured at T_{amb} = 25°C.

Octal D-type flip-flop with data enable; positive edge-trigger

74LV377

AC CHARACTERISTICS

GND = 0V; $t_r = t_f \leq 2.5\text{ns}$; $C_L = 50\text{pF}$; $R_L = 1\text{K}\Omega$

SYMBOL	PARAMETER	WAVEFORM	CONDITION	LIMITS				UNIT	
				-40 to +85 °C			-40 to +125 °C		
				V _{CC} (V)	MIN	TYP ¹	MAX		MIN
t _{PHL} /t _{PLH}	Propagation delay CP to Q _n	Figure 1	1.2	–	80	–	–	ns	
			2.0	–	27	51	–		61
			2.7	–	20	38	–		45
			3.0 to 3.6	–	15 ²	30	–		36
t _W	Clock pulse width HIGH or LOW	Figure 2	2.0	34	9	–	41	ns	
			2.7	25	6	–	30		–
			3.0 to 3.6	20	5 ²	–	24		–
t _{su}	Set-up time D _n to CP	Figure 2	1.2	–	25	–	–	ns	
			2.0	22	9	–	26		–
			2.7	16	6	–	19		–
			3.0 to 3.6	13	5 ²	–	15		–
t _{su}	Set-up time E to CP	Figure 2	1.2	–	10	–	–	ns	
			2.0	22	4	–	26		–
			2.7	16	3	–	19		–
			3.0 to 3.6	13	2 ²	–	15		–
t _h	Hold time D _n to CP	Figure 2	1.2	–	–15	–	–	ns	
			2.0	5	–5	–	5		–
			2.7	5	–4	–	5		–
			3.0 to 3.6	5	–3 ²	–	5		–
t _h	Hold time E to CP	Figure 2	1.2	–	–5	–	–	ns	
			2.0	5	–2	–	5		–
			2.7	5	–2	–	5		–
			3.0 to 3.6	5	–1 ²	–	5		–
f _{max}	Maximum clock pulse frequency	Figure 1	2.0	14	40	–	12	MHz	
			2.7	19	58	–	16		–
			3.0 to 3.6	24	70 ²	–	20		–

NOTES:

1. Unless otherwise stated, all typical values are at T_{amb} = 25°C.
2. Typical value measured at V_{CC} = 3.3V.

Octal D-type flip-flop with data enable; positive edge-trigger

74LV377

AC WAVEFORMS

$V_M = 1.5V$ at $V_{CC} \geq 2.7V$
 $V_M = 0.5V * V_{CC}$ at $V_{CC} < 2.7V$
 V_{OL} and V_{OH} are the typical output voltage drop that occur with the output load.

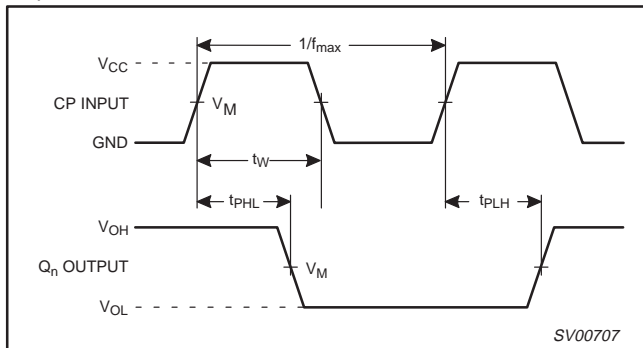

Figure 1. Clock (CP) to output (Qn) propagation delays, the clock pulse width and the maximum clock pulse frequency.

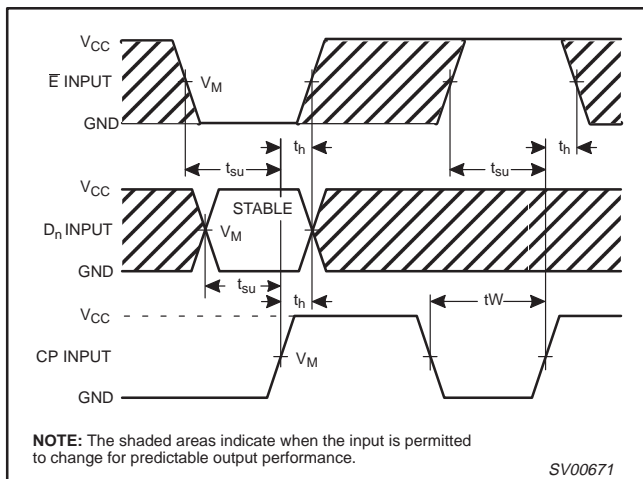

Figure 2. Data set-up and hold times from the data input (Dn) and from the enable input (E) to the clock (CP).

TEST CIRCUIT

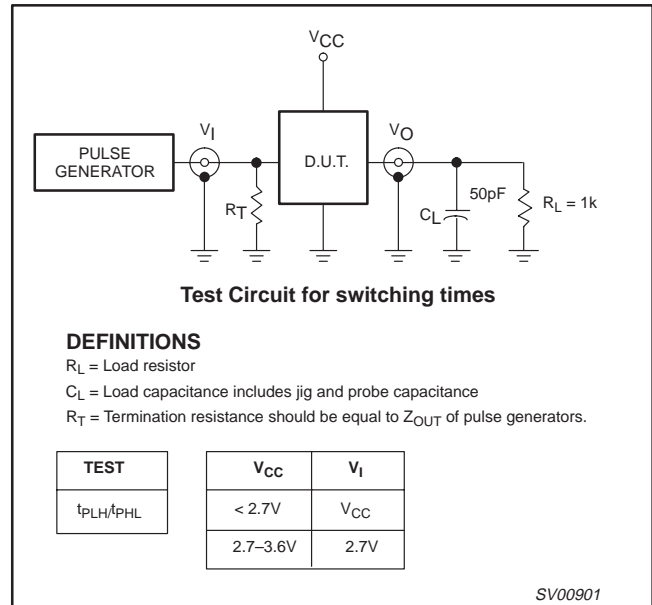

Figure 3. Load circuitry for switching times

Octal D-type flip-flop with data enable;
positive edge-trigger

74LV377

DIP20: plastic dual in-line package; 20 leads (300 mil)

SOT146-1

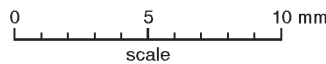
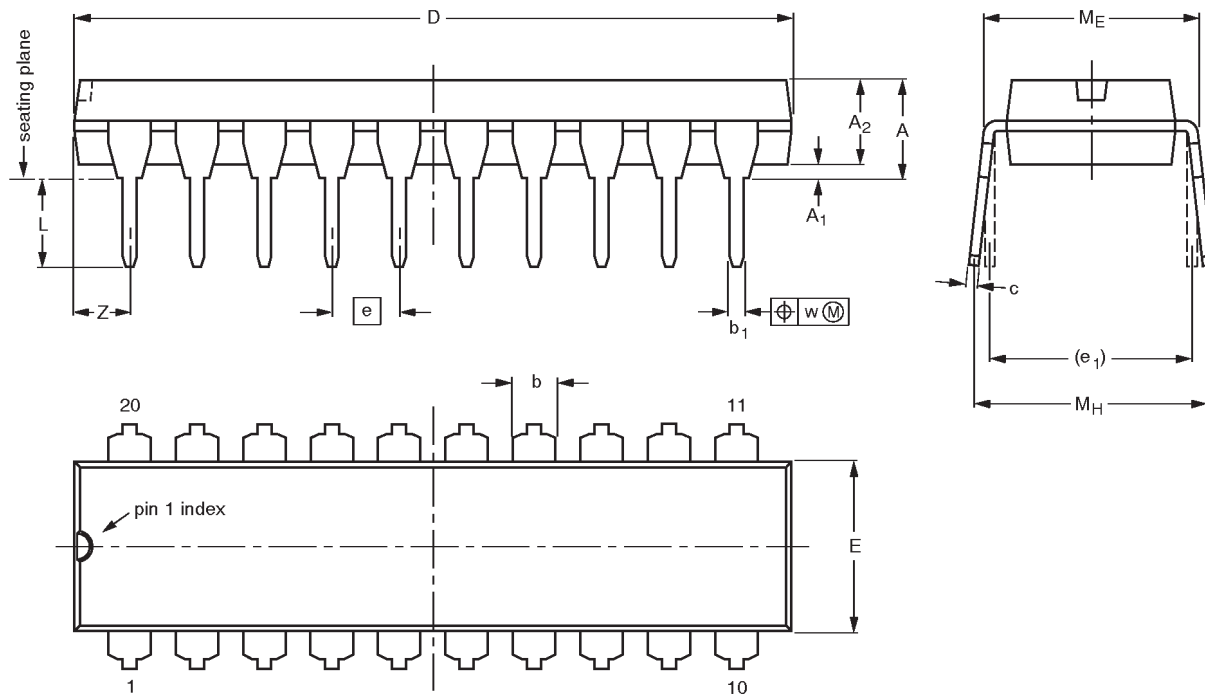

DIMENSIONS (inch dimensions are derived from the original mm dimensions)

UNIT	A max.	A ₁ min.	A ₂ max.	b	b ₁	c	D ⁽¹⁾	E ⁽¹⁾	e	e ₁	L	M _E	M _H	w	Z ⁽¹⁾ max.
mm	4.2	0.51	3.2	1.73 1.30	0.53 0.38	0.36 0.23	26.92 26.54	6.40 6.22	2.54	7.62	3.60 3.05	8.25 7.80	10.0 8.3	0.254	2.0
inches	0.17	0.020	0.13	0.068 0.051	0.021 0.015	0.014 0.009	1.060 1.045	0.25 0.24	0.10	0.30	0.14 0.12	0.32 0.31	0.39 0.33	0.01	0.078

Note

1. Plastic or metal protrusions of 0.25 mm maximum per side are not included.

OUTLINE VERSION	REFERENCES				EUROPEAN PROJECTION	ISSUE DATE
	IEC	JEDEC	EIAJ			
SOT146-1			SC603			-92-11-17 95-05-24

Octal D-type flip-flop with data enable;
positive edge-trigger

74LV377

SO20: plastic small outline package; 20 leads; body width 7.5 mm

SOT163-1

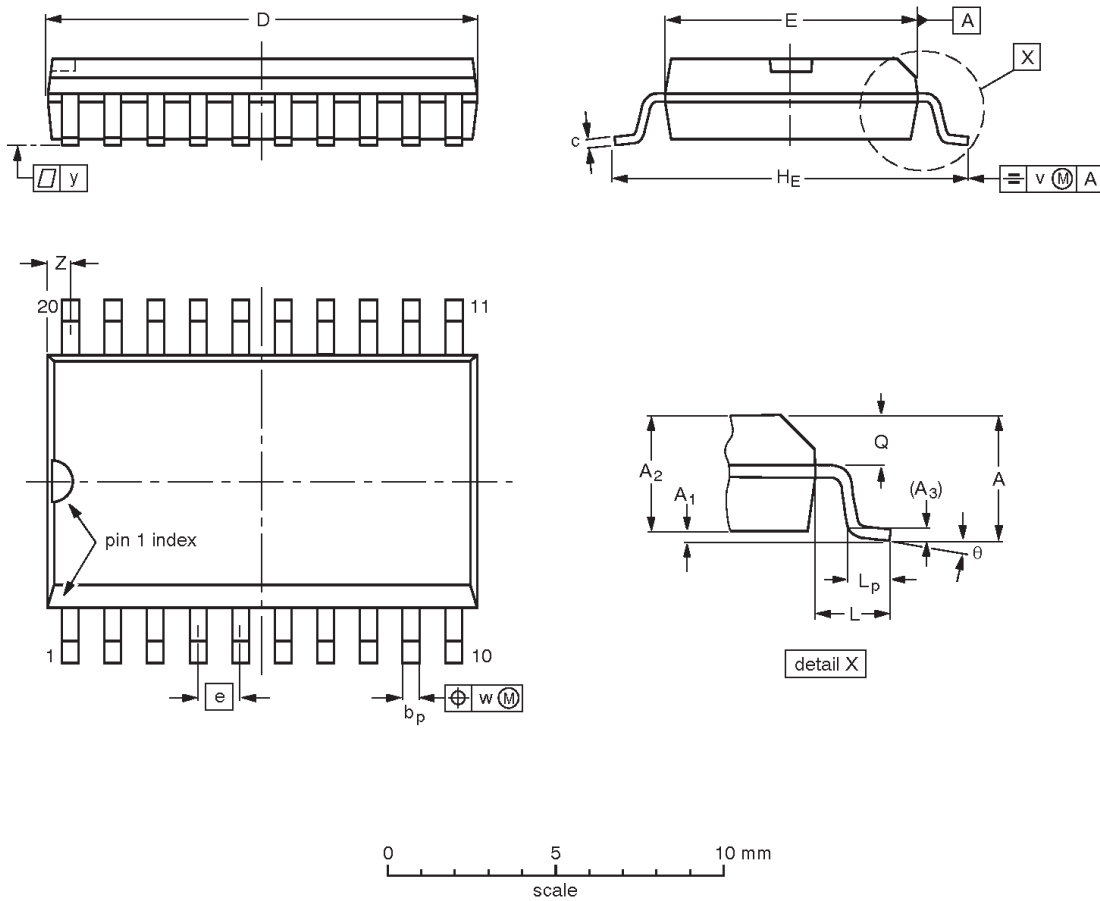

DIMENSIONS (inch dimensions are derived from the original mm dimensions)

UNIT	A max.	A ₁	A ₂	A ₃	b _p	c	D ⁽¹⁾	E ⁽¹⁾	e	H _E	L	L _p	Q	v	w	y	Z ⁽¹⁾	θ
mm	2.65	0.30 0.10	2.45 2.25	0.25	0.49 0.36	0.32 0.23	13.0 12.6	7.6 7.4	1.27	10.65 10.00	1.4	1.1 0.4	1.1 1.0	0.25	0.25	0.1	0.9 0.4	8° 0°
inches	0.10	0.012 0.004	0.096 0.089	0.01	0.019 0.014	0.013 0.009	0.51 0.49	0.30 0.29	0.050	0.42 0.39	0.055	0.043 0.016	0.043 0.039	0.01	0.01	0.004	0.035 0.016	

Note

1. Plastic or metal protrusions of 0.15 mm maximum per side are not included.

OUTLINE VERSION	REFERENCES			EUROPEAN PROJECTION	ISSUE DATE
	IEC	JEDEC	EIAJ		
SOT163-1	075E04	MS-013AC			-92-11-17 95-01-24

Octal D-type flip-flop with data enable;
positive edge-trigger

74LV377

SSOP20: plastic shrink small outline package; 20 leads; body width 5.3 mm

SOT339-1

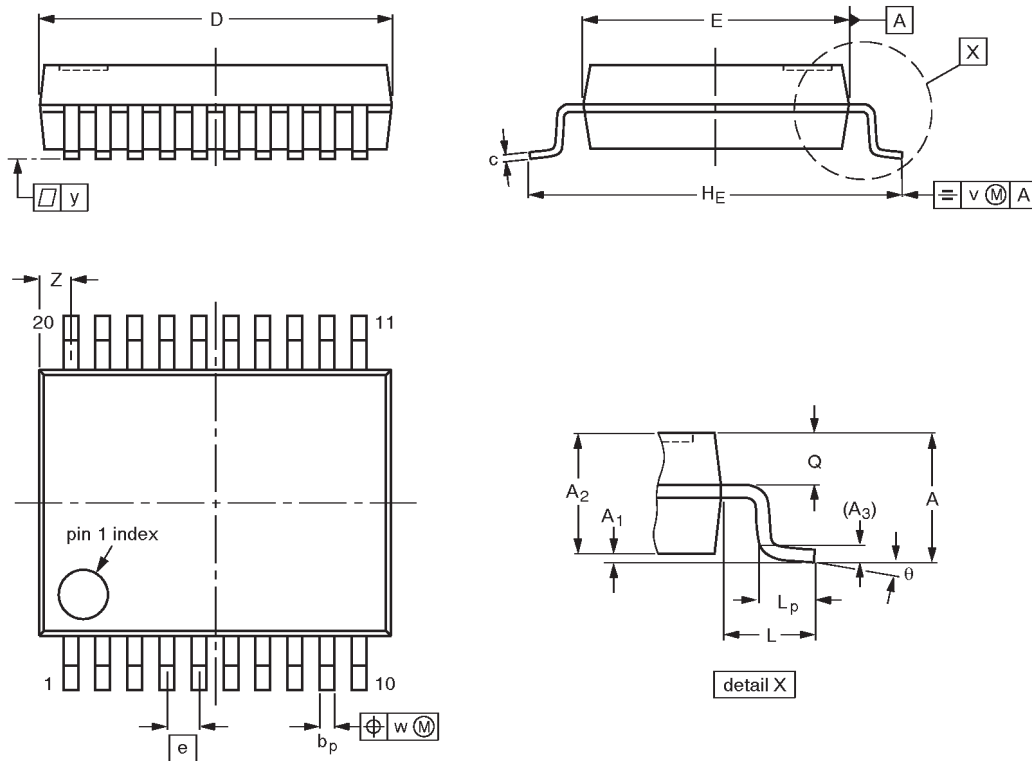

DIMENSIONS (mm are the original dimensions)

UNIT	A max.	A ₁	A ₂	A ₃	b _p	c	D ⁽¹⁾	E ⁽¹⁾	e	H _E	L	L _p	Q	v	w	y	Z ⁽¹⁾	θ
mm	2.0	0.21 0.05	1.80 1.65	0.25	0.38 0.25	0.20 0.09	7.4 7.0	5.4 5.2	0.65	7.9 7.6	1.25	1.03 0.63	0.9 0.7	0.2	0.13	0.1	0.9 0.5	8° 0°

Note

1. Plastic or metal protrusions of 0.20 mm maximum per side are not included.

OUTLINE VERSION	REFERENCES				EUROPEAN PROJECTION	ISSUE DATE
	IEC	JEDEC	EIAJ			
SOT339-1		MO-150AE				93-09-08 95-02-04

Octal D-type flip-flop with data enable;
positive edge-trigger

74LV377

TSSOP20: plastic thin shrink small outline package; 20 leads; body width 4.4 mm

SOT360-1

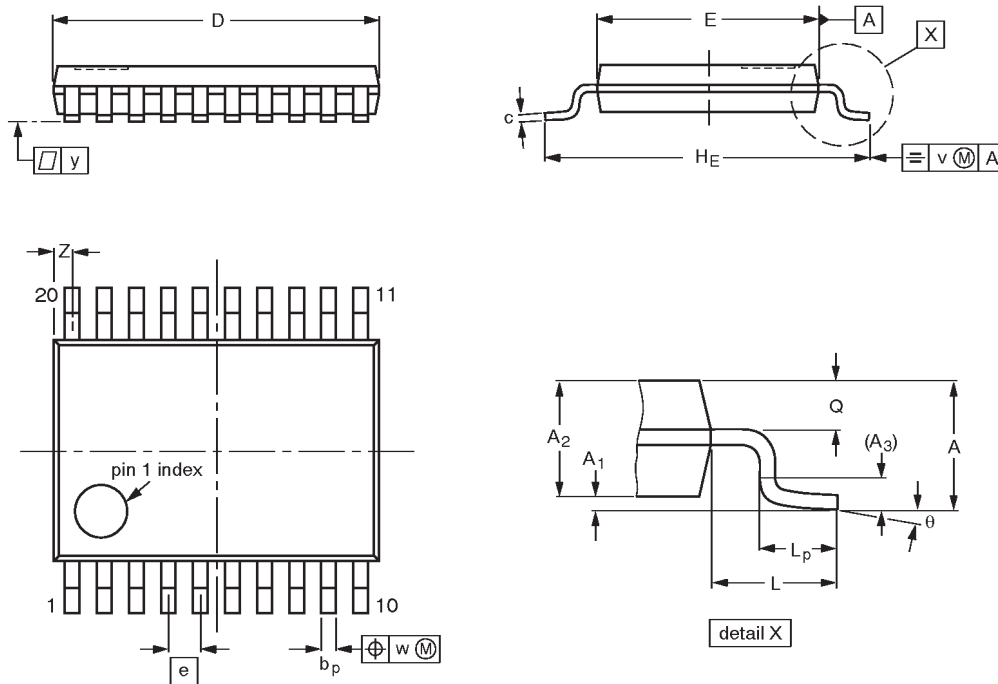

DIMENSIONS (mm are the original dimensions)

UNIT	A max.	A ₁	A ₂	A ₃	b _p	c	D ⁽¹⁾	E ⁽²⁾	e	HE	L	L _p	Q	v	w	y	Z ⁽¹⁾	θ
mm	1.10	0.15 0.05	0.95 0.80	0.25	0.30 0.19	0.2 0.1	6.6 6.4	4.5 4.3	0.65	6.6 6.2	1.0	0.75 0.50	0.4 0.3	0.2	0.13	0.1	0.5 0.2	8° 0°

Notes

1. Plastic or metal protrusions of 0.15 mm maximum per side are not included.
2. Plastic interlead protrusions of 0.25 mm maximum per side are not included.

OUTLINE VERSION	REFERENCES				EUROPEAN PROJECTION	ISSUE DATE
	IEC	JEDEC	EIAJ			
SOT360-1		MO-153AC				93-06-16 95-02-04

Octal D-type flip-flop with data enable; positive edge-trigger

74LV377

DEFINITIONS

Data Sheet Identification	Product Status	Definition
<i>Objective Specification</i>	Formative or in Design	This data sheet contains the design target or goal specifications for product development. Specifications may change in any manner without notice.
<i>Preliminary Specification</i>	Preproduction Product	This data sheet contains preliminary data, and supplementary data will be published at a later date. Philips Semiconductors reserves the right to make changes at any time without notice in order to improve design and supply the best possible product.
<i>Product Specification</i>	Full Production	This data sheet contains Final Specifications. Philips Semiconductors reserves the right to make changes at any time without notice, in order to improve design and supply the best possible product.

Philips Semiconductors and Philips Electronics North America Corporation reserve the right to make changes, without notice, in the products, including circuits, standard cells, and/or software, described or contained herein in order to improve design and/or performance. Philips Semiconductors assumes no responsibility or liability for the use of any of these products, conveys no license or title under any patent, copyright, or mask work right to these products, and makes no representations or warranties that these products are free from patent, copyright, or mask work right infringement, unless otherwise specified. Applications that are described herein for any of these products are for illustrative purposes only. Philips Semiconductors makes no representation or warranty that such applications will be suitable for the specified use without further testing or modification.

LIFE SUPPORT APPLICATIONS

Philips Semiconductors and Philips Electronics North America Corporation Products are not designed for use in life support appliances, devices, or systems where malfunction of a Philips Semiconductors and Philips Electronics North America Corporation Product can reasonably be expected to result in a personal injury. Philips Semiconductors and Philips Electronics North America Corporation customers using or selling Philips Semiconductors and Philips Electronics North America Corporation Products for use in such applications do so at their own risk and agree to fully indemnify Philips Semiconductors and Philips Electronics North America Corporation for any damages resulting from such improper use or sale.

Philips Semiconductors
811 East Arques Avenue
P.O. Box 3409
Sunnyvale, California 94088-3409
Telephone 800-234-7381

© Copyright Philips Electronics North America Corporation 1998
All rights reserved. Printed in U.S.A.

print code

Date of release: 05-96

Document order number:

9397-750-04449

Let's make things better.