



HIGH-EFFICIENCY STEP-DOWN DC-DC CONVERTER

SC1578

January 29, 1998

TEL:805-498-2111 FAX:805-498-3804 WEB:http://www.semtech.com

DESCRIPTION

The SC1578 is a high performance step-down DC-DC converter, designed to drive an external P-channel MOSFET to generate programmable output voltages. Two main schemes of pulse-skipping and pulse-frequency modulation are employed to maintain low quiescent current and high conversion efficiency over wide ranges of input voltage and loads. The SC1578 delivers 10mA to 2A of output current with 87%-93% efficiency at $V_{IN}=9V$, $V_{OUT}=5V$. A current sense comparator with both inverting and non-inverting inputs uncommitted is included to provide the crucial function of either current limit protection or constant output current control. When the SC1578 is used in a high-side current sensing step-down constant current source, the efficiency is typically greater than 90%. Duty cycle can be adjusted to greater than 90% by connecting a resistor from the DUTY pin to V_{IN} . Quiescent current is about 90 μ A and can be reduced to 8 μ A in shutdown mode. With a switching frequency range of 90kHz to 280kHz, small size switching components may be used, which is ideal for battery powered portable equipment.

FEATURES

- 4V to 24V input voltage operation.
- High efficiency (up to 95%).
- Low quiescent current at 90 μ A.
- Pulse-skipping and pulse-frequency modulation.
- Inputs-uncommitted current sense comparator.
- Duty cycle adjustable
- 90kHz to 280kHz oscillator frequency
- Power-saving shutdown mode (8 μ A Typical).
- Push-pull driver output

APPLICATIONS

- Notebook 5V/3.3V main power
- Step-down DC-DC converter module.
- Constant current source for battery chargers.

ORDERING INFORMATION

DEVICE ⁽¹⁾	PACKAGE
SC1578CS	SO-8

Note:

(1) Add suffix 'TR' for tape and reel.

BLOCK DIAGRAM

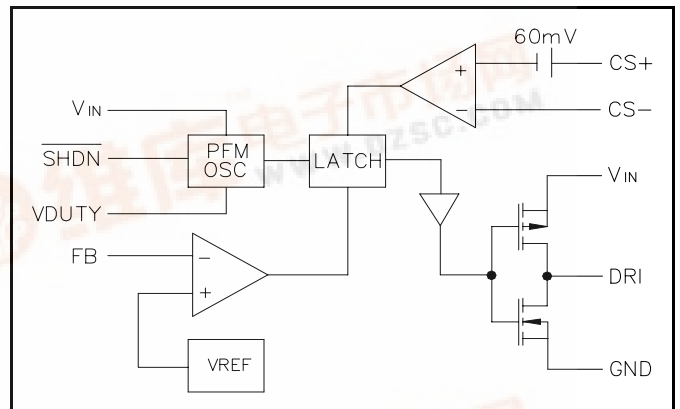

PIN CONFIGURATION

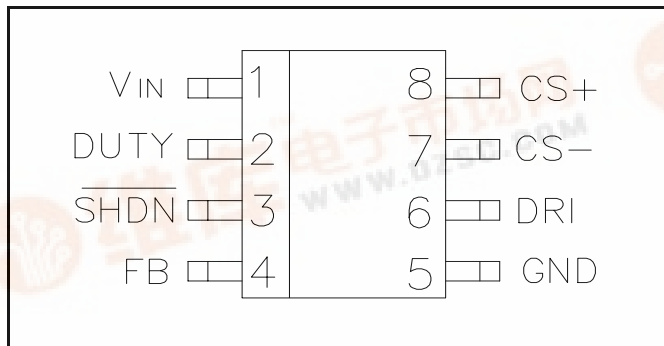

ABSOLUTE MAXIMUM RATINGS

Parameter	Symbol	Maximum	Units
Supply Voltage	V_{IN}	24	V
Duty Voltage	V_{DUTY}	20	V
SHDN Voltage	V_{SHDN}	15	V
Operating Temperature Range	T_A	0 to 70	$^{\circ}$ C
Storage Temperature Range	T_{STG}	-65 to 150	$^{\circ}$ C



January 29, 1998

ELECTRICAL CHARACTERISTICS

 Unless otherwise specified, $T_A = 25^\circ\text{C}$, $V_{IN} = 13\text{V}$

Parameter		Conditions	Min	Typ	Max	Units
Operation Voltage			4		24	V
Quiescent Current		$V_{FB} = 1.5\text{V}$		90	160	μA
Shutdown Mode Current		$V_{SHDN} = 0\text{V}$		8	20	μA
Internal Reference Voltage			1.16	1.22	1.28	V
Driver Sinking "On resistance"				16		Ω
Driver Sourcing "On resistance"				11		Ω
Current Sense Comparator Threshold	1578 1578A	$V_{CS+} = 13\text{V}$	42 52	57 57	72 62	mV
Shutdown Threshold			0.8	1.5	2.4	V
SHDN Pin Leakage Current		$V_{SHDN} < 15\text{V}$			1	μA
Duty Cycle		$V_{DUTY} = V_{IN}$		71		%
Oscillator Frequency		$V_{DUTY} = V_{IN}$		225		kHz

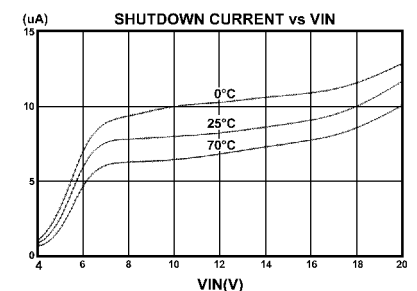
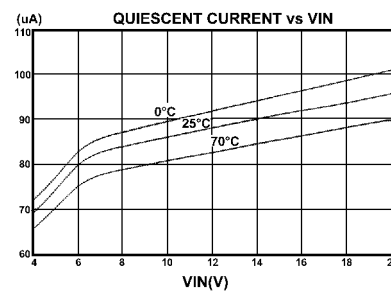
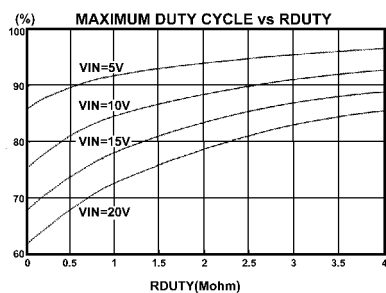
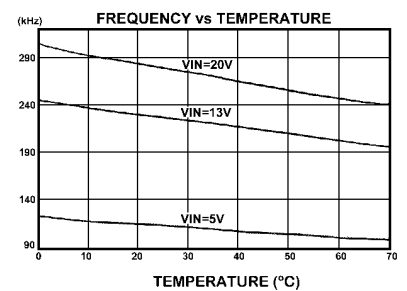
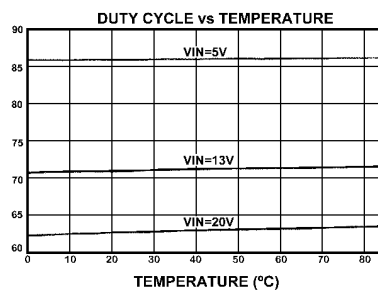
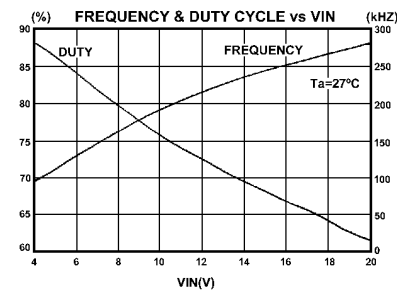
TYPICAL PERFORMANCE CHARACTERISTICS

January 29, 1998

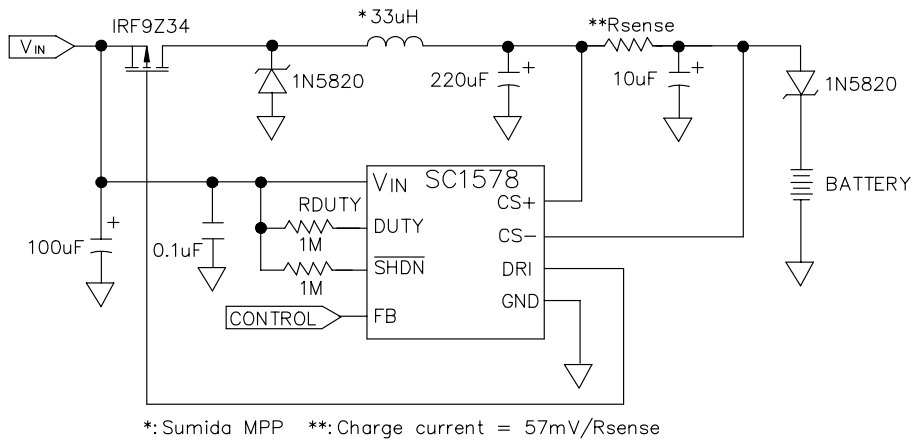
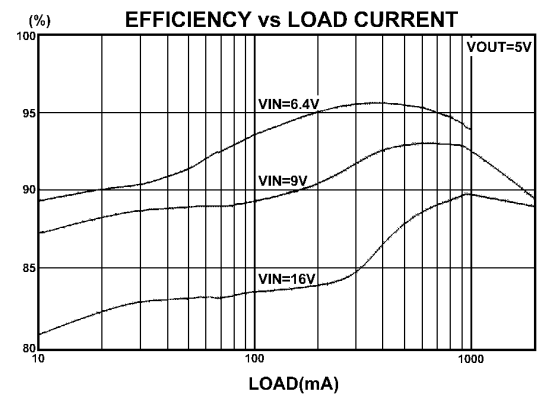
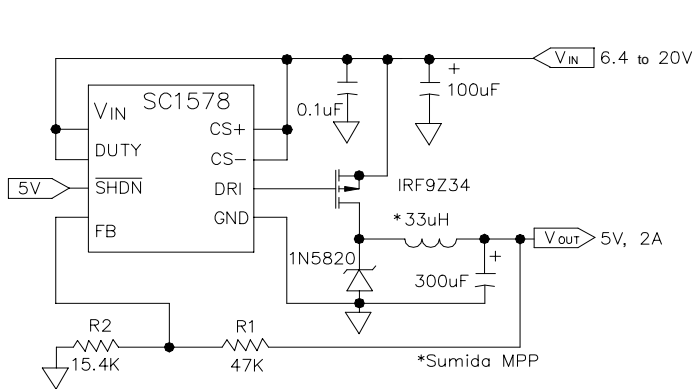
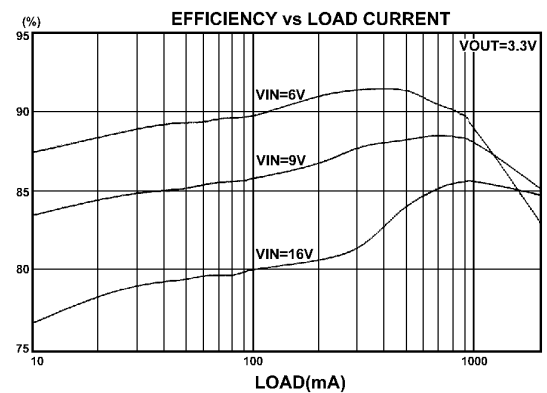
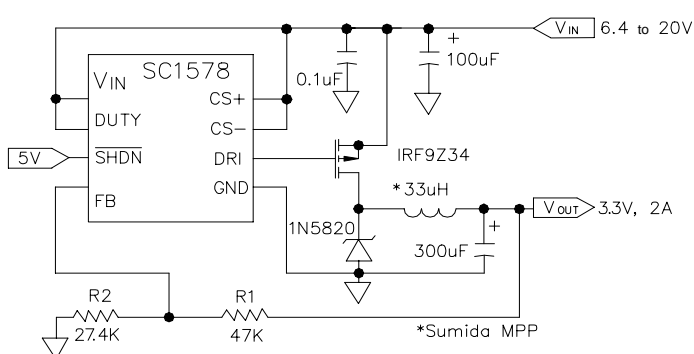
TYPICAL APPLICATION CIRCUIT

APPLICATION EXAMPLES

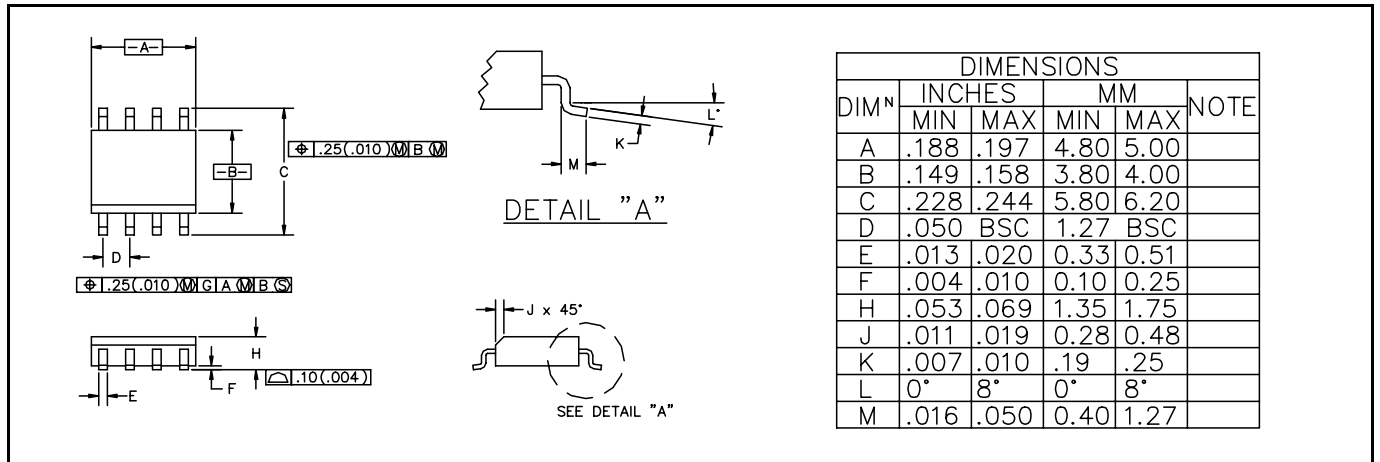
Figure 1. 5V Step-Down Converter

Figure 2. 3.3V Step-Down Converter

January 29, 1998

DEVICE OUTLINE - SO-8

LAND PATTERN - SO-8
