

NEC

SILICON MMIC LOW CURRENT AMPLIFIER FOR MOBILE COMMUNICATIONS

UPC8179TK

FEATURES

- **HIGH DENSITY SURFACE MOUNTING:**
6 Pin Leadless Minimold Package (1.5 x 1.1 x 0.55 mm)
- **SUPPLY VOLTAGE:**
Vcc = 2.4 to 3.3 V
- **HIGH EFFICIENCY:**
Po(1dB) = +2.0 dBm TYP at f = 1.0 GHz
Po(1dB) = +0.5 dBm TYP at f = 1.9 GHz
Po(1dB) = +0.5 dBm TYP at f = 2.4 GHz
- **POWER GAIN:**
GP = 13.5 dB TYP at f = 1.0 GHz
GP = 15.5 dB TYP at f = 1.9 GHz
GP = 16.0 dB TYP at f = 2.4 GHz
- **EXCELLENT ISOLATION:**
ISL = 43 dB TYP at f = 1.0 GHz
ISL = 42 dB TYP at f = 1.9 GHz
ISL = 42 dB TYP at f = 2.4 GHz
- **LOW CURRENT CONSUMPTION:**
Icc = 4.0 mA TYP AT VCC = 3.0 V
- **OPERATING FREQUENCY:**
0.1 to 2.4 GHz (Output port LC matching)
- **LIGHT WEIGHT:**
3 mg

APPLICATION

- Buffer amplifiers for 0.1 to 2.4 GHz mobile communications systems.

OUTLINE DIMENSIONS (Units in mm)

PACKAGE OUTLINE TK

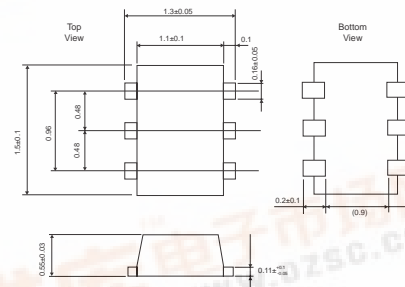

DESCRIPTION

NEC's UPC8179TK is a silicon monolithic integrated circuit designed as an amplifier for mobile communications. This IC can realize low current consumption with external chip inductor. The incorporation of a chip identical to the conventional 6-pin super minimold package (2.0 x 1.25 x 0.9 mm) μ PC8179TB in a 6-pin leadless minimold package (1.5 x 1.1 x 0.55 mm) has enabled a reduction in mounting area of 50%. The μ PC8179TK is ideally suited to replace the μ PC8179TB for footprint reduction and increased design density. This IC is manufactured using NEC's 30 GHz fMAX UHS0 (Ultra High Speed Process) silicon bipolar process. This process uses direct silicon nitride passivation film and gold electrodes. These materials can protect the chip surface from pollution and prevent corrosion/migration. Thus this IC has excellent performance uniformity and reliability.

NEC's stringent quality assurance and test procedures assure the highest performance, consistency and reliability.

ELECTRICAL CHARACTERISTICS,

(Unless otherwise specified, TA = +25°C, VCC = VOUT = 3.0 V, ZS = ZL = 50Ω, at LC matched Frequency)

PART NUMBER PACKAGE OUTLINE			UPC8179TK TK		
SYMBOLS	PARAMETERS AND CONDITIONS	UNITS	MIN	TYP	MAX
Icc	Circuit Current (no input signal)	mA	2.9	4.0	5.4
GP	Power Gain, f = 1.0 GHz, PIN = -30 dBm f = 1.9 GHz, PIN = -30 dBm f = 2.4 GHz, PIN = -30 dBm	dB	11.0 13.0 14.0	13.5 15.5 16.0	15.5 17.5 18.5
ISOL	Isolation, f = 1.0 GHz, PIN = -30 dBm f = 1.9 GHz, PIN = -30 dBm f = 2.4 GHz, PIN = -30 dBm	dB	39.0 37.0 37.0	43.0 42.0 42.0	— — —
P1dB	Output Power at 1 dB gain compression, f = 1.0 GHz f = 1.9 GHz f = 2.4 GHz	dBm	-0.5 -2.0 -3.0	2.0 0.5 0.5	— — —
NF	Noise Figure, f = 1.0 GHz f = 1.9 GHz f = 2.4 GHz	dB	— — —	5.0 5.0 5.0	6.5 6.5 6.5
RLIN	Input Return Loss, (without matching circuit) f = 1.0 GHz, PIN = -30 dBm f = 1.9 GHz, PIN = -30 dBm f = 2.4 GHz, PIN = -30 dBm	dB	4.0 4.0 6.0	7.0 7.0 9.0	— — —

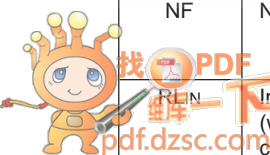

UPC8179TK

ABSOLUTE MAXIMUM RATINGS¹ (T_A = 25°C)

SYMBOLS	PARAMETERS	UNITS	RATINGS
V _{CC}	Supply Voltage	V	3.6
I _{CC}	Circuit Current	mA	15
P _D	Power Dissipation ²	mW	232
T _{OP}	Operating Temperature	°C	-40 to +85
T _{STG}	Storage Temperature	°C	-55 to +150
P _{IN}	Input Power	dBm	+5

Notes:

1. Operation in excess of any one of these parameters may result in permanent damage.
2. Mounted on a 50 x 50 x 1.6 mm epoxy glass PWB (T_A = +85°C).

RECOMMENDED OPERATING CONDITIONS

SYMBOLS	PARAMETERS	UNITS	MIN	TYP	MAX
V _{CC}	Supply Voltage	V	2.4	3.0	3.3
T _A	Operating Ambient Temperature	°C	-40	+25	+85

PIN CONNECTIONS

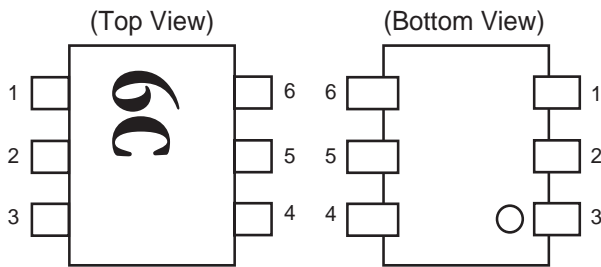

PIN NO.	PIN NAME
1	INPUT
2	GND
3	GND
4	OUTPUT
5	GND
6	V _{CC}

Caution: pin arrangement differs from the conventional 6 pin super minimold type UPC8179TB –

SERIES PRODUCTS¹ (T_A = +25°C, V_{CC} = V_{out} = 3.0 V, Z_S = Z_L = 50 Ω)

Parameter Part No.	I _{CC} (mA)	1.0 GHz output port matching frequency			1.9 GHz output port matching frequency			2.4 GHz output port matching frequency			Package
		GP (dB)	ISOL (dB)	PO(1 dB) (dBm)	GP (dB)	ISOL (dB)	PO(1 dB) (dBm)	GP (dB)	ISOL (dB)	PO(1 dB) (dBm)	
UPC8178TB	1.9	11	39	-4.0	11.5	40	-7.0	11.5	38	-7.5	6 pin super minimold
UPC8178TK	1.9	11	40	-5.5	11.0	41	-8.0	11.0	42	-8.0	6 pin leadless minimold
UPC8179TB	4.0	13.5	44	+3.0	15.5	42	+1.5	15.5	41	+1.0	6 pin super minimold
UPC8179TK	4.0	13.5	43	+2.0	15.5	42	+0.5	16.0	42	+0.5	6 pin leadless minimold
UPC8128TB	2.8	12.5	39	-4.0	13	37	-4.0	–	–	–	6 pin super minimold
UPC8151TB	4.2	12.5	38	+2.5	15	34	+0.5	–	–	–	6 pin super minimold
UPC8152TB	5.6	23	40	-4.5	17.5	35	-8.5	–	–	–	6 pin super minimold

Note:

1. Typical performance.

SYSTEM APPLICATION EXAMPLE

Location examples in digital cellular

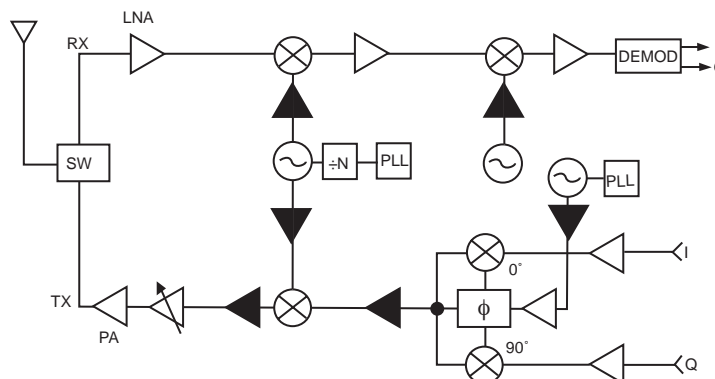

EVALUATION BOARD, 0.9 GHz

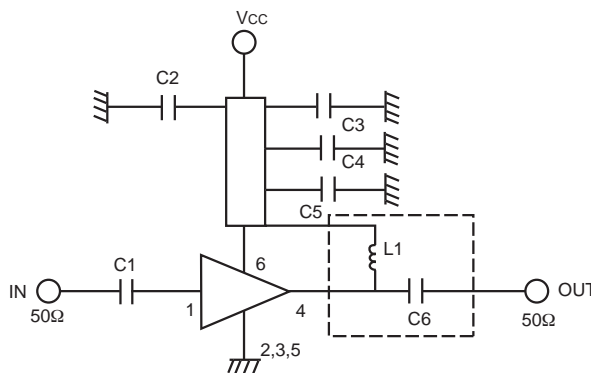
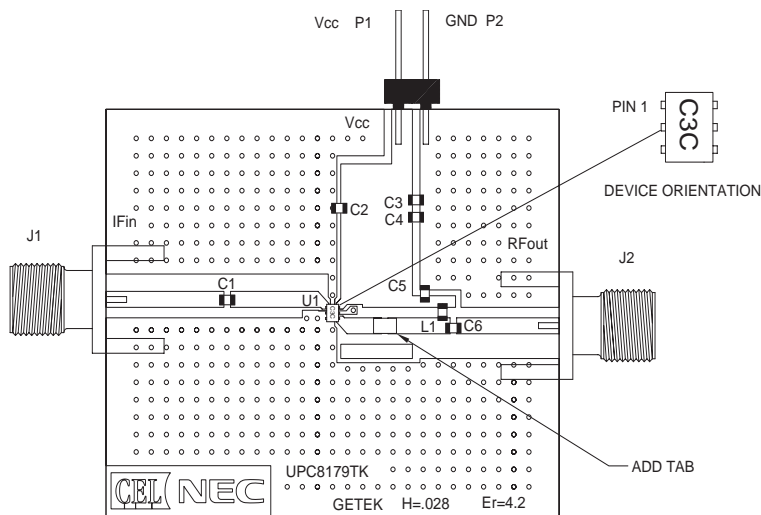

COMPONENT LIST

FORM	SYMBOL	VALUE
Chip Capacitor	C6	1 pF
	C1, C5	51 pF
	C2, C3, C4	1800 pF
Chip Inductor	L1	10 nH

1. 1.5 x 1.5 x 0.028", Getek laminate, double sided copper
2. Ground pattern on rear board
3. Solder plated patterns
4. \circ Through holes

EVALUATION BOARD, 1.9 GHz

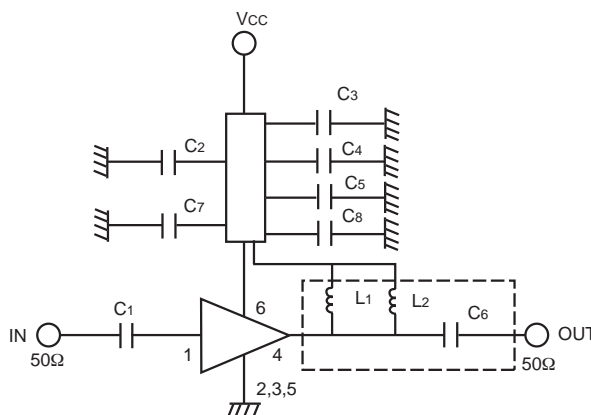
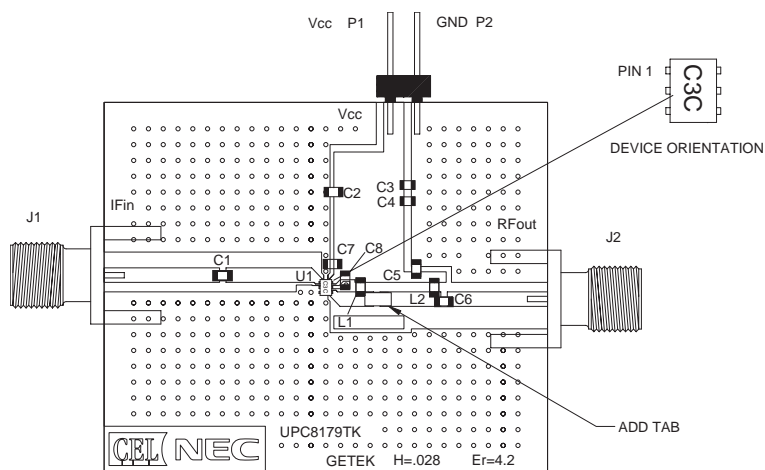

COMPONENT LIST

FORM	SYMBOL	VALUE
Chip Capacitor	C7, C8	10 pF
	C6	.4 pF
	C1, C5	51 pF
	C2, C3, C4	1000 pF
Chip Inductor	L2	22 nH
	L1	2.7 nH

1. 1.5 x 1.5 x 0.028", Getek laminate, double sided copper
2. Ground pattern on rear board
3. Solder plated patterns
4. \circ Through holes

UPC8179TK

EVALUATION BOARD, 2.4 GHz

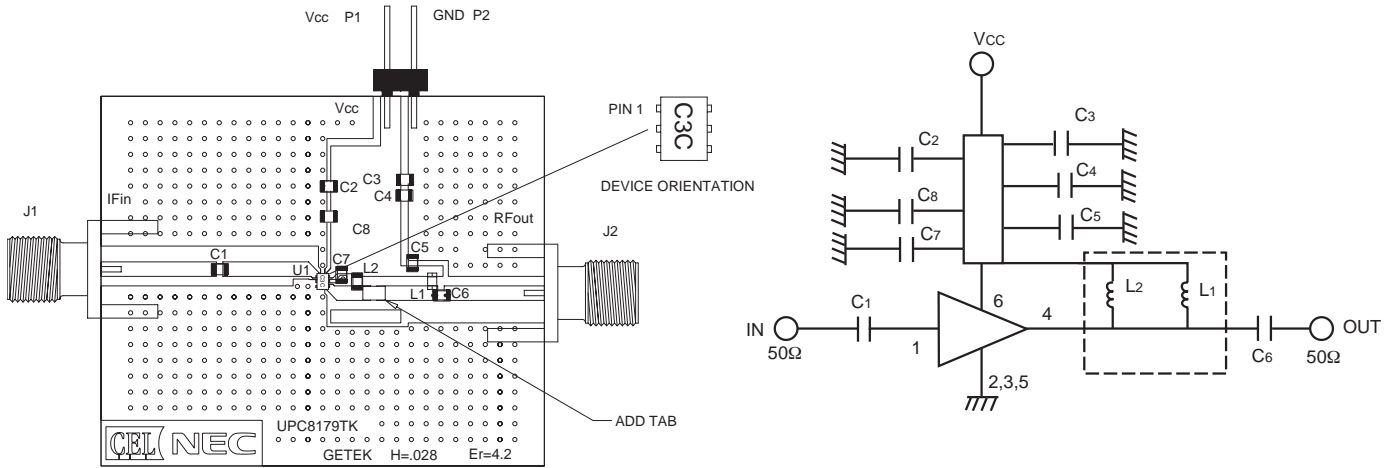

COMPONENT LIST

FORM	SYMBOL	VALUE
Chip Capacitor	C7	5.6 pF
	C6	0.5 pF
	C1, C5	51 pF
	C2, C3, C4, C8	1000 pF
Chip Inductor	L2	3.9 nH
	L1	2.7 nH

1. 1.5 x 1.5 x 0.028", Getek laminate, double sided copper
2. Ground pattern on rear board
3. Solder plated patterns
4. ○ Through holes

TYPICAL SCATTERING PARAMETERS (T_A = 25°C)

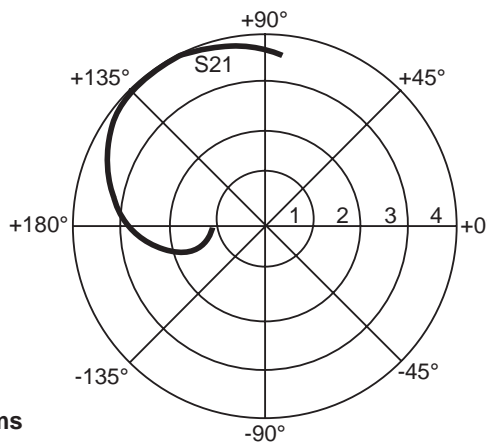
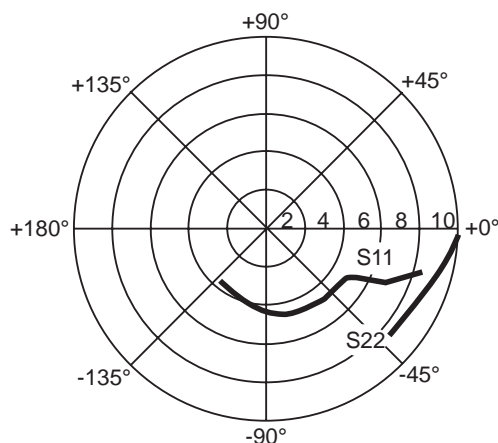

Coordinates in Ohms
Frequency in GHz
0.100 to 3.000 GHz by 0.100

V_{CC} = V_{OUT} = 3.0 V

FREQUENCY

GHz	S ₁₁		S ₂₁		S ₁₂		S ₂₂		K	MAG
	MAG (lin)	ANG (deg)	MAG (lin)	ANG (deg)	MAG (lin)	ANG (deg)	MAG (lin)	ANG (deg)		
0.100	0.84	-15.44	0.000	144.28	1.10	-177.39	1.00	-1.76	0.21	33.63
0.200	0.71	-23.58	0.001	74.92	1.11	-172.09	0.99	-3.33	3.26	20.89
0.300	0.62	-26.85	0.003	79.88	1.18	-167.46	0.98	-4.59	2.99	18.84
0.400	0.57	-27.79	0.004	74.10	1.29	-163.89	0.97	-5.92	3.20	17.29
0.500	0.53	-28.46	0.004	69.27	1.43	-162.03	0.97	-7.05	3.64	16.66
0.600	0.51	-29.20	0.005	64.73	1.58	-161.77	0.96	-8.16	3.83	16.34
0.700	0.50	-30.41	0.005	57.60	1.76	-162.65	0.95	-9.33	3.87	16.49
0.800	0.49	-31.91	0.006	55.38	1.94	-164.38	0.94	-10.38	3.64	16.74
0.900	0.48	-33.73	0.006	52.35	2.14	-167.03	0.94	-11.45	3.54	17.08
1.000	0.48	-35.99	0.006	50.82	2.34	-170.16	0.93	-12.51	3.41	17.48
1.100	0.48	-38.71	0.007	46.83	2.54	-174.19	0.92	-13.62	3.29	17.79
1.200	0.48	-41.75	0.007	44.54	2.74	-178.44	0.92	-14.78	3.28	18.12
1.300	0.48	-45.45	0.006	43.45	2.94	176.74	0.91	-15.97	3.53	18.29
1.400	0.48	-49.58	0.006	40.78	3.14	171.66	0.90	-17.28	3.56	18.55
1.500	0.47	-54.02	0.006	41.20	3.32	166.25	0.90	-18.52	3.67	18.71
1.600	0.47	-58.93	0.006	41.10	3.48	160.62	0.89	-19.81	4.05	18.93
1.700	0.46	-64.06	0.005	46.39	3.63	154.76	0.88	-21.15	4.19	19.03
1.800	0.46	-69.22	0.006	41.00	3.75	148.78	0.88	-22.35	4.06	19.12
1.900	0.45	-74.64	0.005	41.04	3.85	142.70	0.87	-23.73	4.76	19.06
2.000	0.44	-80.15	0.005	46.54	3.92	136.64	0.87	-25.15	4.90	19.06
2.100	0.43	-85.84	0.005	48.59	3.95	130.61	0.86	-26.53	5.61	18.93
2.200	0.42	-91.30	0.004	58.65	3.98	124.75	0.86	-27.99	6.26	18.88
2.300	0.41	-97.01	0.004	70.83	3.97	119.03	0.86	-29.67	7.20	18.71
2.400	0.40	-102.52	0.004	78.30	3.95	113.51	0.86	-31.15	6.49	18.60
2.500	0.39	-107.66	0.005	83.94	3.90	108.09	0.85	-32.65	5.82	18.38
2.600	0.39	-112.50	0.005	86.81	3.86	103.05	0.85	-34.43	5.48	18.33
2.700	0.38	-117.21	0.005	91.39	3.79	97.97	0.85	-35.87	6.19	18.08
2.800	0.37	-121.34	0.005	100.87	3.73	93.14	0.85	-37.50	6.53	17.91
2.900	0.37	-125.50	0.005	108.40	3.64	88.56	0.85	-39.28	5.80	17.71
3.000	0.36	-129.41	0.006	110.47	3.57	84.13	0.85	-40.88	5.16	17.50

$$MAG = \frac{|S_{21}|}{|S_{12}|} \left(K \pm \sqrt{K^2 - 1} \right), \text{ When } K \leq 1, \text{ MAG is undefined and MSG values are used.}$$

$$MSG = \frac{|S_{21}|}{|S_{12}|},$$

$$K = \frac{1 + |\Delta|^2 - |S_{11}|^2 - |S_{22}|^2}{2 |S_{12}| |S_{21}|},$$

$$\Delta = S_{11} S_{22} - S_{21} S_{12}$$

Note:

1. Data taken at Device Under Test pins

UPC8179TK

OUTLINE DIMENSIONS (Units in mm)

PACKAGE OUTLINE TK

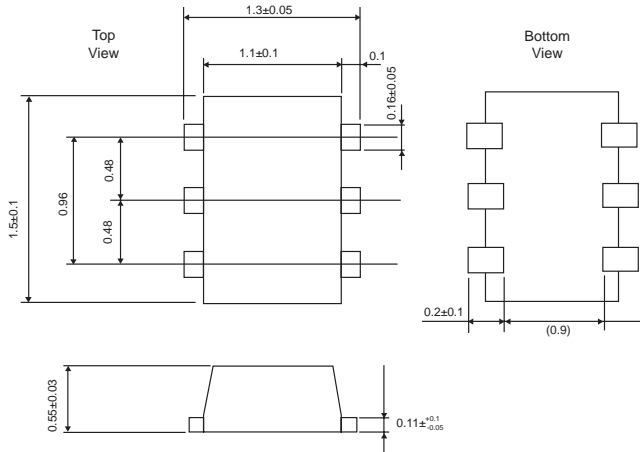

ORDERING INFORMATION

PART NUMBER	QTY
UPC8179TK-E3	3K/Reel

Note:

Embossed tape, 8 mm wide. Pins 1, 2, 3 are in tape pull-out direction.

Life Support Applications

These NEC products are not intended for use in life support devices, appliances, or systems where the malfunction of these products can reasonably be expected to result in personal injury. The customers of CEL using or selling these products for use in such applications do so at their own risk and agree to fully indemnify CEL for all damages resulting from such improper use or sale.