



7A LDO 3-Pin Adjustable Linear Regulator

Description

The CS5207A-1 linear regulator provides 7A at adjustable voltages from 1.25V to 5V. This adjustable device requires two external resistors to set the output voltage and provide the minimum load current for proper regulation.

This regulator is intended for use as a post regulator and microprocessor supply. The fast loop response and low dropout voltage make this regulator ideal for applications where low voltage operation and good transient response are important.

The circuit is designed to operate with dropout voltages as low as 1.0V at 7A.

This regulator is protected against overload conditions with overcurrent and thermal shutdown protection circuitry.

The CS5207A-1 is pin compatible with the LT1584 family of linear regulators but has lower dropout voltage and faster transient response.

This regulator is available in a TO-220 package.

Features

- 1.25V to 5V V_{OUT} at 7A
- Dropout Voltage < 1.0V @ 7A
- 1.5% Trimmed Reference
- Fast Transient Response
- Thermal Shutdown
- Current Limit
- Short Circuit Protection
- Drop-In Replacement for LT1584

Applications Diagram

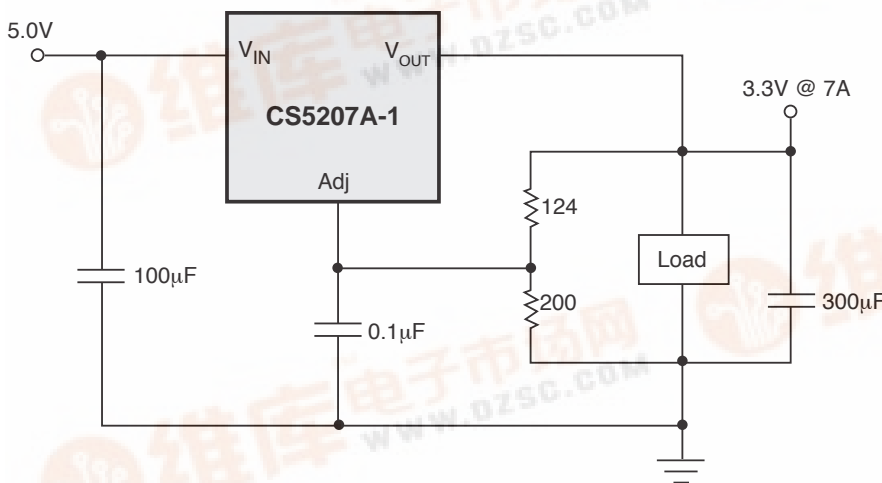

Package Options

3 Lead TO-220

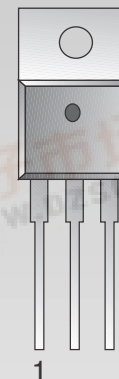

1. Adjust
 2. V_{OUT}
 3. V_{IN}
- Tab = V_{OUT}

Absolute Maximum Ratings

Input Voltage.....	6V
Operating Junction Temperature Range	0°C ≤ T _J ≤ 150°C
Storage Temperature Range	-65°C to +150°C
Lead Temperature Soldering	
Wave Solder (through hole styles only).....	10 sec. max, 260°C peak
ESD Damage Threshold	2kV

Electrical Characteristics: 0°C ≤ T_A = 70°C, 0°C ≤ T_J = 150°C, V_{Adj} = 0V unless otherwise specified.

PARAMETER	TEST CONDITIONS	MIN	TYP	MAX	UNIT
Reference voltage	V _{IN} =2.75V to 5.5V, I _{OUT} =10mA to 7A	1.234 (-1.5%)	1.253	1.271 (+1.5%)	V
Line Regulation	V _{IN} =2.75V to 5.5V, I _{OUT} =10mA		.02	.20	%
Load Regulation	V _{IN} =2.75V, I _{OUT} =10mA to 7A		.04	.50	%
Minimum Load Current (Note 1)	V _{IN} =5V, ΔV _{OUT} =+1.5%		5	10	mA
Adjust Pin Current	V _{IN} =2.75V, I _{OUT} =10mA		70	120	μA
Current Limit	V _{IN} =2.75V, ΔV _{OUT} = -1.5%	7.1	8.0		A
Short Circuit Current	V _{IN} =2.75V, V _{OUT} =0V	5.0	9.0		A
Ripple Rejection (Note 2)	V _{IN} =3.25V, V _{Ripple} =1V _{P-P} @120Hz, I _{OUT} =4A, C _{Adj} =0.1μF; C _{OUT} = 22μF	60	80		dB
Thermal Regulation (Note 2)	30ms Pulse, T _A =25°C		0.002		%/W
Dropout Voltage (Minimum V _{IN} -V _{OUT}) (Note 3)	I _{OUT} =100mA I _{OUT} =1A I _{OUT} =2.75A I _{OUT} =4A I _{OUT} =7A		0.92 0.93 0.94 0.95 0.96	1.15 1.15 1.15 1.15 1.25	V V V V V
RMS Output Noise	Freq=10Hz to 10kHz, T _A =25°C		0.003		%V _{OUT}
Temperature Stability			0.5		%
Thermal Shutdown (Note 4)		150	180	210	°C
Thermal Shutdown Hysteresis (Note 4)			25		°C

Note 1: The minimum load current is the minimum current required to maintain regulation. Normally the current in the resistor divider used to set the output voltage is selected to meet the minimum load current requirement.

Note 2: This parameter is guaranteed by design and is not 100% production tested.

Note 3: Dropout voltage is defined as the minimum input/output voltage differential required to maintain 1.5% regulation.

Note 4: This parameter is guaranteed by design, but not parametrically tested in production. However, a 100% thermal shutdown functional test is performed on each part.

Package Pin Description

PACKAGE PIN #	PIN SYMBOL	FUNCTION
3L TO-220		
1	Adjust	This pin is connected to the low side of the internally trimmed 1.5% bandgap reference voltage and carries a bias current of about 70μA. A resistor divider from Adj to V _{OUT} and from Adj to ground sets the output voltage. Also, transient response can be improved by adding a small bypass capacitor from this pin to ground.
2	V _{OUT}	This pin is connected to the emitter of the power pass transistor and provides a regulated voltage capable of sourcing 7A of current.
3	V _{IN}	This is the supply voltage for the regulator. For the device to regulate, this voltage should be between 1V and 1.25V (depending on the output current) greater than the output voltage.

Block Diagram

CS5207A-1

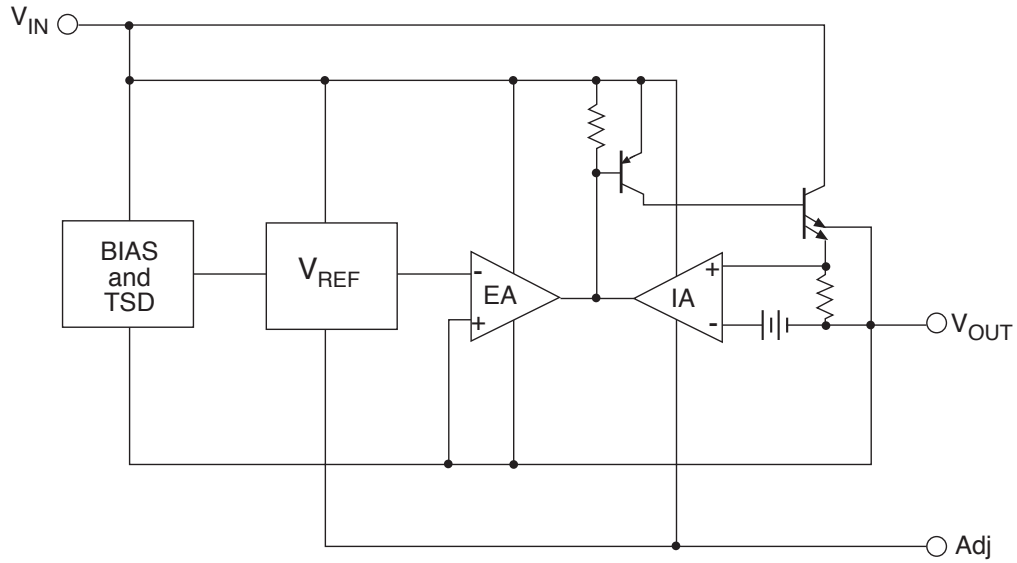

Typical Performance Characteristics

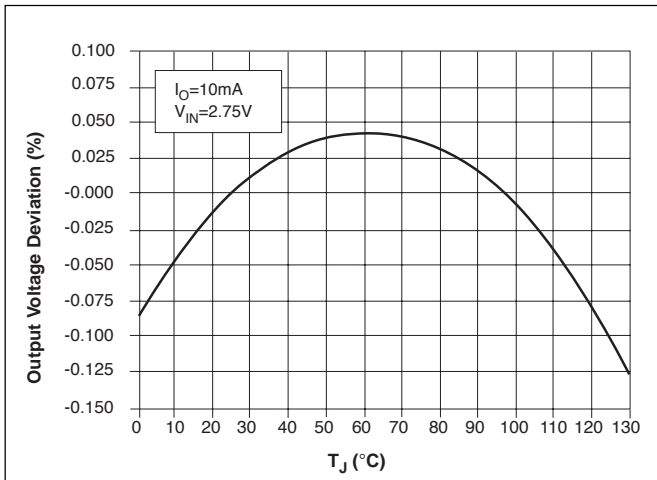

Reference Voltage vs. Temperature

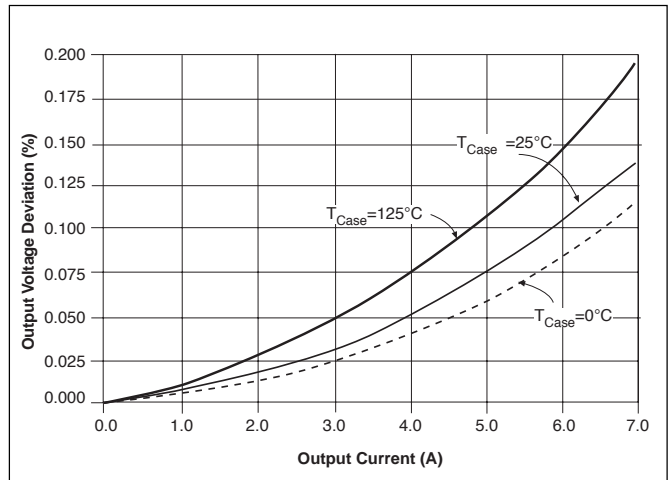

Load Regulation vs. Output Current

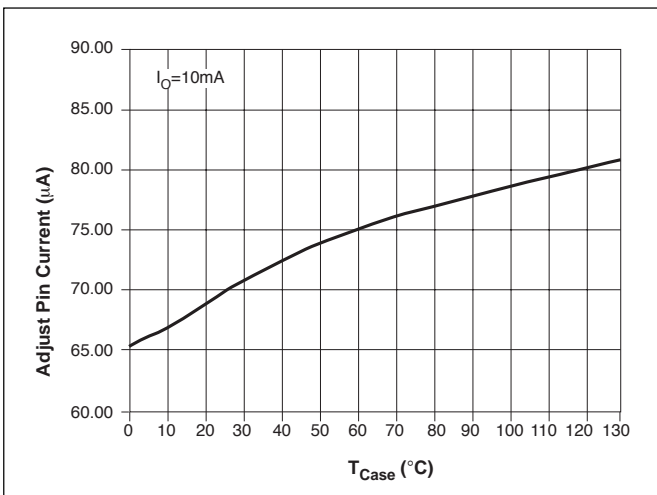

Adjust Pin Current vs. Temperature

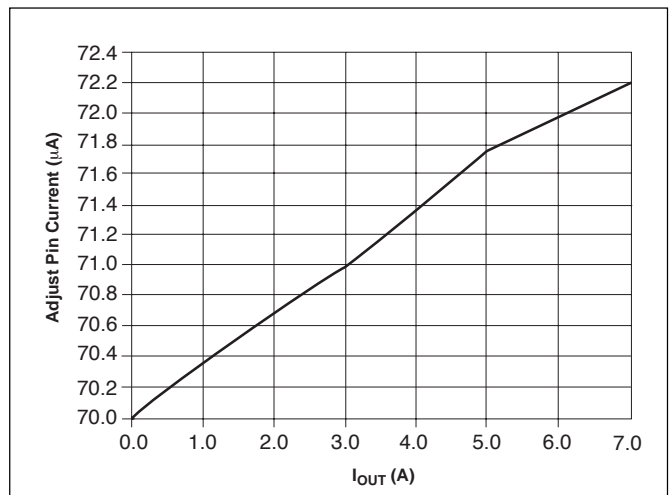

Adjust Pin Current vs. I_{OUT}

Typical Performance Characteristics: continued

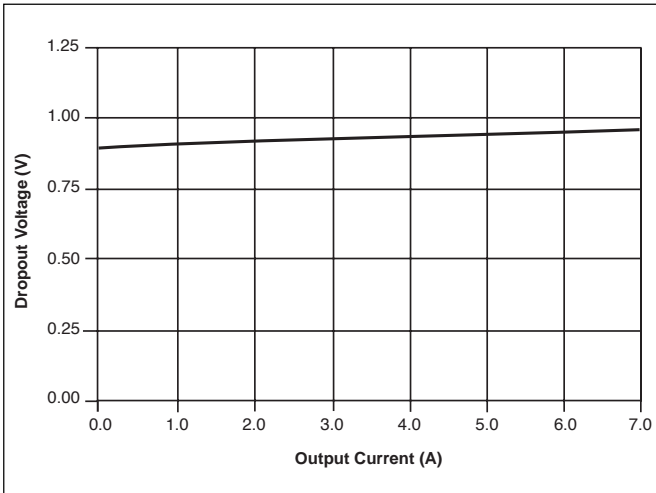

Dropout Voltage vs. Output Current

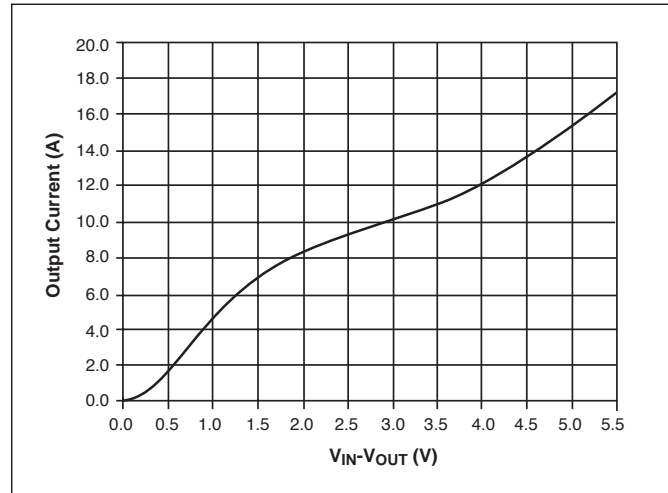
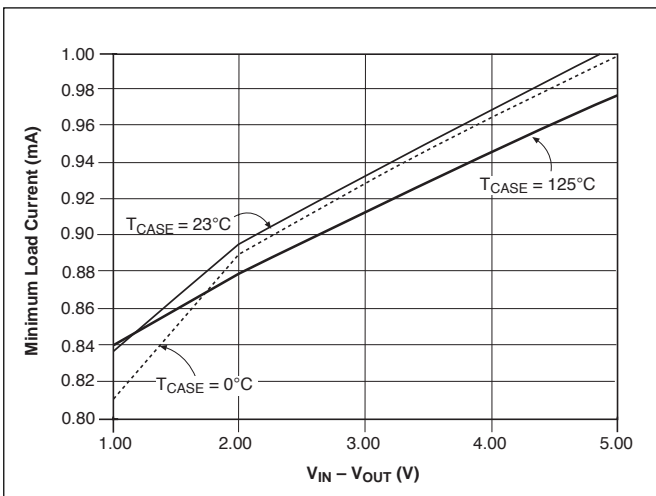
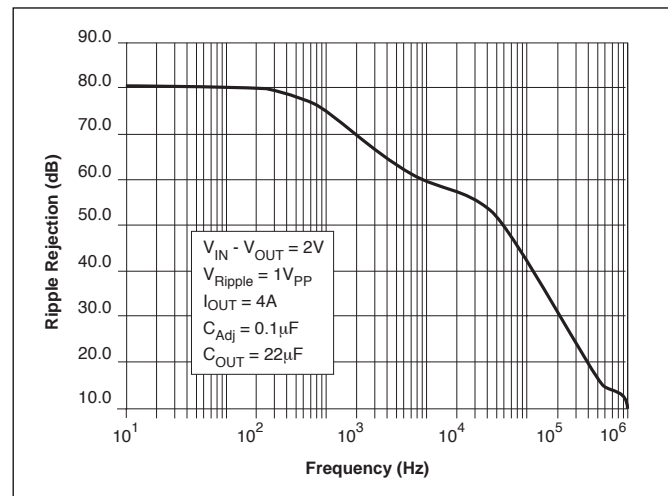
Short Circuit Current vs. $V_{IN} - V_{OUT}$ Minimum Load Current vs. $V_{IN} - V_{OUT}$ 

Ripple Rejection vs. Frequency

Application Notes

Theory of Operation

The CS5207A-1 linear regulator has a composite PNP-NPN output stage that requires an output capacitor for stability. A detailed procedure for selecting this capacitor is included in the Stability Considerations section.

Adjustable Operation

Design Guidelines

This LDO adjustable regulator has an output voltage range of 1.25V to 5V. An external resistor divider sets the output voltage as shown in Figure 1. The regulator's voltage sensing error amplifier maintains a fixed 1.25V reference between the output pin and the adjust pin.

A resistor divider network R_1 and R_2 causes a fixed current to flow to ground. This current creates a voltage across R_2

that adds to the 1.25V across R_1 and sets the overall output voltage. The adjust pin current (typically $50\mu\text{A}$) also flows through R_2 and adds a small error that should be taken into account if precise adjustment of V_{out} is necessary. The output voltage is set according to the formula:

$$V_{OUT} = V_{REF} \times \frac{R_1 + R_2}{R_1} + R_2 \times I_{Adj}$$

The term $I_{Adj} \times R_2$ represents the error added by the adjust pin current.

R_1 is chosen so that the minimum load current is at least 10mA. R_1 and R_2 should be of the same composition for best tracking over temperature. For best results, the divider resistor should be placed near the regulator with a separate metal trace connecting them to output.

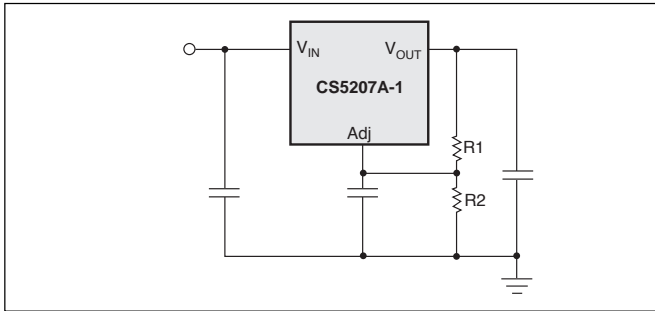

Figure 1.

While not required, a bypass capacitor connected between the adjust pin and ground will improve transient response and ripple rejection. A $0.1\mu\text{F}$ tantalum capacitor is recommended for “first cut” design. Value and type may be varied to optimize performance vs. price.

Other Adjustable Operation Considerations

The CS5207A-1 linear regulator has an absolute maximum specification of 6V for the voltage difference between V_{IN} and V_{OUT} . However, the IC may be used to regulate voltages in excess of 6V. The main considerations in such a design are power-up and short circuit capability.

In most applications, ramp-up of the power supply to V_{IN} is fairly slow, typically on the order of several tens of milliseconds, while the regulator responds in less than one microsecond. In this case, the linear regulator begins charging the output capacitor as soon as the V_{IN} to V_{OUT} differential is large enough that the pass transistor conducts current. V_{OUT} is essentially at ground, and V_{IN} is on the order of several hundred millivolts, so the pass transistor is in dropout. As V_{IN} increases, the pass transistor will remain in dropout, and current is passed to the load until V_{OUT} is in regulation. Further increase in V_{IN} brings the pass transistor out of dropout. The result is that the output voltage follows the power supply ramp-up, staying in dropout until the regulation point is reached. In this manner, any output voltage may be regulated. There is no theoretical limit to the regulated voltage as long as the V_{IN} to V_{OUT} differential of 6V is not exceeded.

However, maximum ratings of the IC will be exceeded in a short circuit condition. Short circuit conditions will result in the immediate operation of the pass transistor outside of its safe operating area. Over-voltage stresses will then cause destruction of the pass transistor before overcurrent or thermal shutdown circuitry can become active.

Additional circuitry may be required to clamp V_{IN} to V_{OUT} differential to less than 6V if failsafe operation is required. One possible clamp circuit is illustrated below; however, the design of clamp circuitry must be done on an application by application basis. Care must be taken to ensure the clamp actually protects the design. Components used in the clamp design must be able to withstand the short circuit conditions indefinitely while protecting the IC.

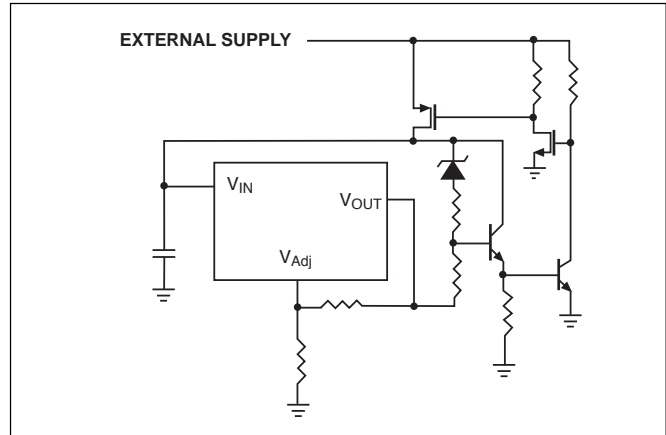

Figure 2.

Stability Considerations

The output compensation capacitor helps determine three main characteristics of a linear regulator: start-up delay, load transient response, and loop stability.

The capacitor value and type is based on cost, availability, size and temperature constraints. A tantalum or aluminum electrolytic capacitor is best, since a film or ceramic capacitor with almost zero ESR can cause instability. The aluminum electrolytic capacitor is the least expensive solution. However, when the circuit operates at low temperatures, both the value and ESR of the capacitor will vary considerably. The capacitor manufacturer's data sheet provides this information.

A $300\mu\text{F}$ tantalum capacitor will work for most applications, but with high current regulators such as the CS5207A-1 the transient response and stability improve with higher values of capacitance. The majority of applications for this regulator involve large changes in load current so the output capacitor must supply the instantaneous load current. The ESR of the output capacitor causes an immediate drop in output voltage given by:

$$\Delta V = \Delta I \times \text{ESR}.$$

For microprocessor applications it is customary to use an output capacitor network consisting of several tantalum and ceramic capacitors in parallel. This reduces the overall ESR and reduces the instantaneous output voltage drop under transient load conditions. The output capacitor network should be as close to the load as possible for the best results.

Protection Diodes

When large external capacitors are used with a linear regulator it is sometimes necessary to add protection diodes. If the input voltage of the regulator gets shorted, the output capacitor will discharge into the output of the regulator. The discharge current depends on the value of the capacitor, the output voltage, and the rate at which V_{IN} drops. In the CS5207A-1 regulator, the discharge path is through a large junction and protection diodes are not usually needed. If the regulator is used with large values of output capacitance and the input voltage is instantaneously shorted to ground, damage can occur. In this case, a diode connected as shown in Figure 3 is recommended.

A rule of thumb useful in determining if a protection diode is required is to solve for current

$$I = \frac{C \times V}{T}, \text{ where}$$

I is the current flow out of the load capacitance when V_{IN} is shorted,

C is the value of the load capacitance,

V is the output voltage, and

T is the time duration required for V_{IN} to transition from high to being shorted.

If the calculated current is greater than or equal to the typical short circuit current value provided in the specifications, serious thought should be given to including a protection diode.

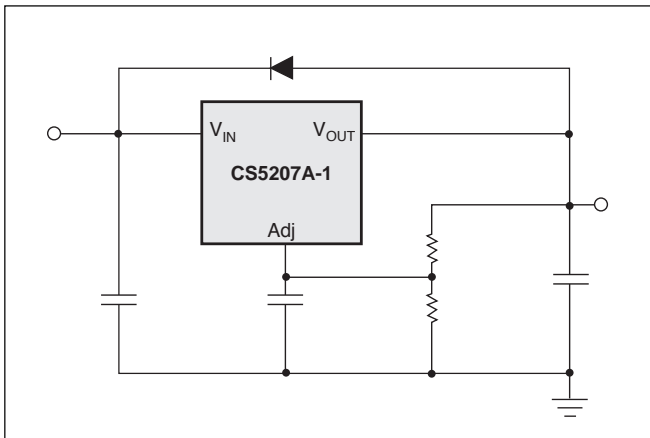

Figure 3.

Current Limit

The internal current limit circuit limits the output current under excessive load conditions, and protects the regulator.

Short Circuit Protection

The device includes foldback short circuit current limit that clamps the output current at approximately two amperes less than its current limit value.

Thermal Shutdown

The thermal shutdown circuitry is guaranteed by design to become activated above a die junction temperature of 150°C and to shut down the regulator output. This circuitry includes a thermal hysteresis circuit with 25°C of typical hysteresis, thereby allowing the regulator to recover from a thermal fault automatically.

Calculating Power Dissipation and Heat Sink Requirements

High power regulators such as the CS5207A-1 usually operate at high junction temperatures. Therefore, it is important to calculate the power dissipation and junction temperatures accurately to ensure that an adequate heat sink is used. Since the package tab is connected to V_{OUT} on the CS5207A-1, electrical isolation may be required for some applications. Also, as with all high power packages, thermal compound is necessary to ensure proper heat flow. For added safety, this high current LDO includes an internal thermal shutdown circuit.

The thermal characteristics of an IC depend on the following four factors. Junction temperature, ambient temperature, die power dissipation, and the thermal resistance from the die junction to ambient air. The maximum junction temperature can be determined by:

$$T_{J(max)} = T_{A(max)} + PD_{(max)} \times R_{\theta JA}$$

The maximum ambient temperature and the power dissipation are determined by the design while the maximum junction temperature and the thermal resistance depend on the manufacturer and the package type. The maximum power dissipation for a regulator is:

$$PD_{(max)} = (V_{IN(max)} - V_{OUT(min)})I_{OUT(max)} + V_{IN(max)} \times I_{IN(max)}$$

A heat sink effectively increases the surface area of the package to improve the flow of heat away from the IC and into the surrounding air. Each material in the heat flow path between the IC and the outside environment has a thermal resistance which is measured in degrees per watt. Like series electrical resistances, these thermal resistances are summed to determine the total thermal resistance between the die junction and the surrounding air, $R_{\theta JA}$. This total thermal resistance is comprised of three components. These resistive terms are measured from junction to case ($R_{\theta JC}$), case to heat sink ($R_{\theta CS}$), and heat sink to ambient air ($R_{\theta SA}$). The equation is:

$$R_{\theta JA} = R_{\theta JC} + R_{\theta CS} + R_{\theta SA}$$

$R_{\theta JC}$ is rated @ 1.4°C/W for the CS5207A-1. For a high current regulator such as the CS5207A-1 the majority of heat is generated in the power transistor section. The value for $R_{\theta SA}$ depends on the heat sink type, while the $R_{\theta CS}$ depends on factors such as package type, heat sink interface (is an insulator and thermal grease used?), and the contact area between the heat sink and the package. Once these calculations are complete, the maximum permissible value of $R_{\theta JA}$ can be calculated and the proper heat sink selected. For further discussion on heat sink selection, see our Cherry application note "Thermal Management for Linear Regulators."

Package Specification

CS5207A-1

PACKAGE DIMENSIONS IN mm (INCHES)

PACKAGE THERMAL DATA

Thermal Data		3L TO-220	
$R_{\theta JC}$	typ	1.4	$^{\circ}\text{C}/\text{W}$
$R_{\theta JA}$	typ	50	$^{\circ}\text{C}/\text{W}$

3 Lead TO-220 (T) Straight

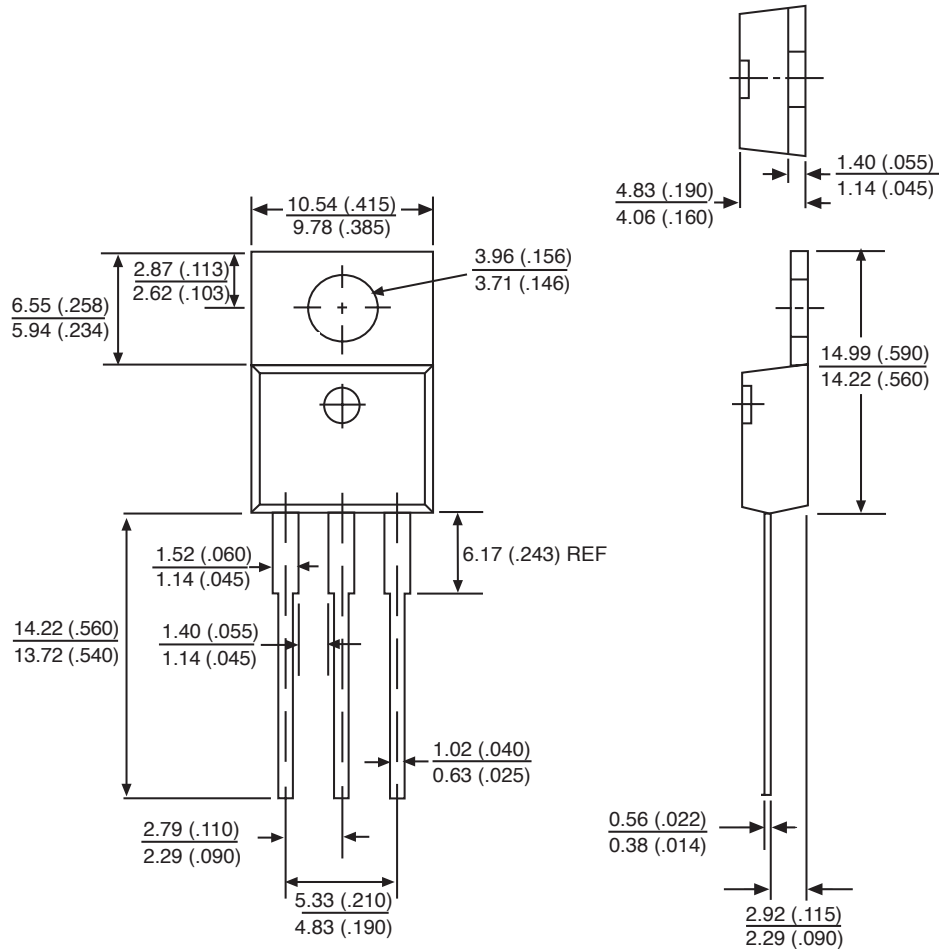

Ordering Information

Part Number	Description
CS5207A-1GT3	3L TO-220 Straight

Cherry Semiconductor Corporation reserves the right to make changes to the specifications without notice. Please contact Cherry Semiconductor Corporation for the latest available information.