



L4957A

UP TO 5A ULDO LINEAR REGULATOR

PRODUCT PREVIEW

- 1.5V, 1.8V, 2.5V AND 3.3V FIXED OUTPUT VOLTAGE
- 3V TO 14V INPUT VOLTAGE RANGE
- 200mΩ R_{dson} TYPICAL @ T_j = 125°C
- 0.6V max. DROP-OUT AT 2A
- EXCELLENT LOAD REGULATION
- 0.6mA QUIESCENT CURRENT AT ANY LOAD
- SHORT CIRCUIT PROTECTION
- THERMAL SHUTDOWN

APPLICATIONS

- MOTHER BOARDS
- PROCESSOR I/O & SUPPLIES
- LOW VOLTAGE MEMORY & CHIP SET SUPPLIES
- GRAPHIC & SOUND CARDS
- LOW VOLTAGE LOGIC SUPPLIES
- POST REGULATOR FOR SMPS

DESCRIPTION

The L4957A devices are **Ultra Low Drop Output** linear regulators with an internal N-channel MOS of 200mΩ particularly suitable for low voltage/low dropout applications.

Operating with a input voltage from 3V to 14V they are capable to deliver up to 5A.

The devices are ideal for use as one of the sup-

MULTIPOWER BCD TECHNOLOGY

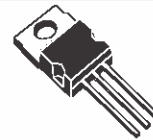

Versawatt TO-220



D²PAK

ORDERING NUMBERS:

L4957AV1.5
L4957AV1.8
L4957AV2.5
L4957AV3.3

L4957AD1.5
L4957AD1.8
L4957AD2.5
L4957AD3.3

plies required by processor, for example they are the cost effective and efficient solution for conversion from 3.3V (rail bus) to 2.5V @ 2.5A or to 1.5V with high current rating.

Fast response transient minimise the output capacitor value. A minimum of 22μF assures the stability in all load conditions.

The on-chip trimming technique offers a tighter voltage reference tolerance (with ± 2% including line and load variation) beside to ensure a controlled short circuit current. Thermal shutdown provides protection against overload conditions that creates excessive junction temperature.

TYPICAL APPLICATION

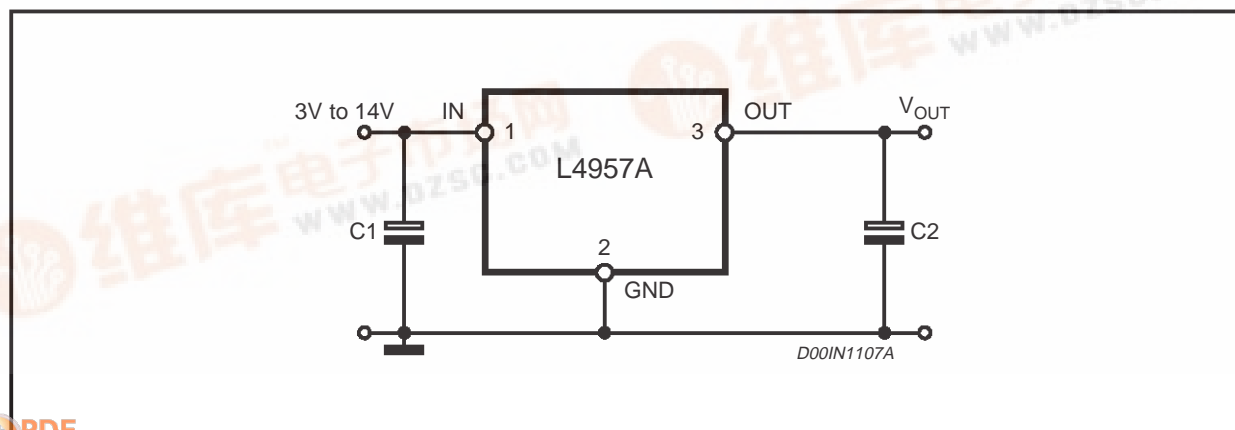

L4957A

ABSOLUTE MAXIMUM RATINGS

Symbol	Parameter	Value	Unit
V_{IN}	Supply Input Voltage	16	V
T_j	Junction Temperature	-40 to +150	°C
T_{stg}	Storage Temperature	-40 to +150	°C

PINS CONNECTION

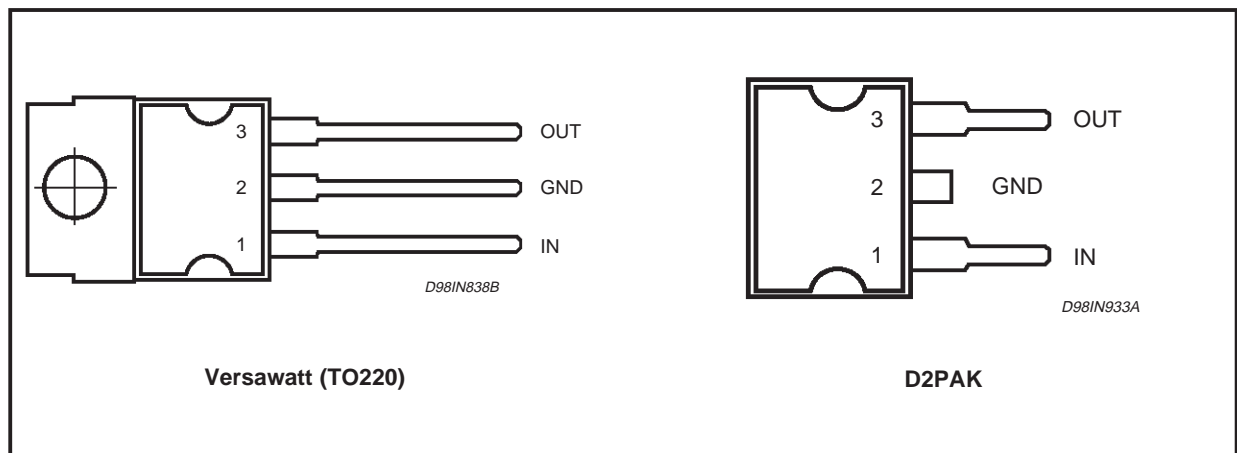

BLOCK DIAGRAM

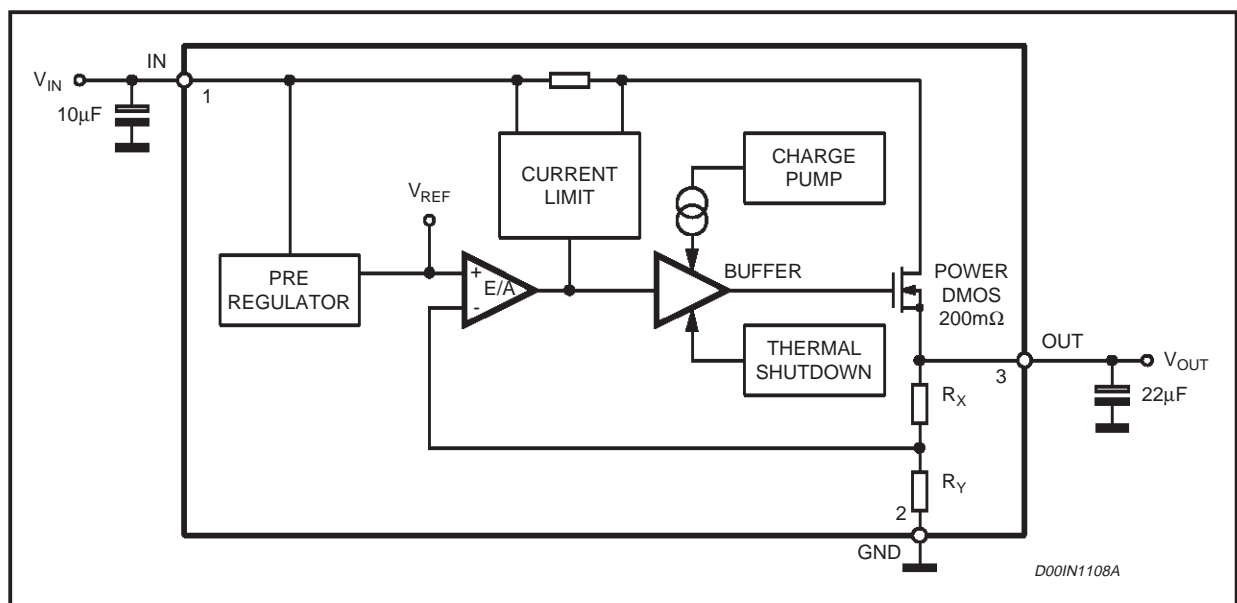

PIN FUNCTIONS

Pin N°	Name	Function
1	IN	Unregulated input voltage; this pin must be bypassed with a capacitor larger than $10\mu\text{F}$.
2	GND	To connect to Ground to get 1.5V, 1.8V, 2.5V or 3.3V output.
3	OUT	Regulated output voltage. A minimum bypass capacitor of $22\mu\text{F}$ is required to insure stability.

THERMAL DATA

Symbol	Parameter		TO220	D2PAK	Unit
$R_{th\ j-case}$	Thermal Resistance Junction-case	Max.	2.5	3	°C/W
$R_{th\ j-amb}$	Thermal Resistance Junction-ambient	Max.	50	60	°C/W
	Thermal Shutdown	Typ.	150		°C
	Thermal Hysteresis	Typ.	20		°C

ELECTRICAL CHARACTERISTICS ($T_j = 25^\circ\text{C}$, $V_{IN} = 5\text{V}$, unless otherwise specified).● = Specifications referred to T_j from 0°C to $+125^\circ\text{C}$.

Symbol	Parameter	Test Condition	Min.	Typ.	Max.	Unit
V_{IN}	Operating Supply Voltage		3		14	V
V_O	Output Voltage	$3.15\text{V} < V_{IN} < 5.25\text{V}; I_O = 0.1\text{A}$	1.485	1.5	1.515	V
		$V_{IN} = 3.3\text{V} \pm 5\%; 0.1\text{A} < I_O < 5\text{A}$	● 1.47	1.5	1.53	V
		$V_{IN} = 3.3\text{V} \pm 5\% \quad I_O = 0.1\text{A}$ $V_{IN} = 5\text{V} \pm 5\%$	1.782	1.8	1.818	V
		$V_{IN} = 3.3\text{V} \pm 5\% \quad (0.1\text{A} < I_O < 45\text{A})$ $V_{IN} = 5\text{V} \pm 5\% \quad 0.1\text{A} < I_O < 5\text{A}$	● 1.764	1.8	1.836	V
		$V_{IN} = 3.3\text{V} \pm 5\% \quad I_O = 0.1\text{A}$ $V_{IN} = 5\text{V} \pm 5\%$	2.475	2.5	2.525	V
		$V_{IN} = 3.3\text{V} \pm 5\% \quad (0.1\text{A} < I_O < 2.2\text{A})$ $V_{IN} = 5\text{V} \pm 5\% \quad 0.1\text{A} < I_O < 5\text{A}$	● 2.45	2.5	2.55	V
		$V_{IN} = 5\text{V} \pm 5\% \quad I_O = 0.1\text{A}$	3.267	3.3	3.333	V
		$V_{IN} = 5\text{V} \pm 5\% \quad 0.1\text{A} < I_O < 5\text{A}$	● 3.234	3.3	3.366	V
$R_{DS(on)}$	Drain-Source ON Resistance		●		300	m Ω
I_O	Current Limiting		● 5.1	6.3	7.5	A
I_Q	Quiescent Current	$3\text{V} < V_{IN} < 14\text{V}$	●	0.6	2	mA
	Ripple Rejection	$f = 120\text{Hz}, I_O = 1\text{A}$ $V_{IN} = 5\text{V} \quad \Delta V_{IN} = 2V_{PP}$	60	75		dB

Figure 1: Line Regulation vs. Junction Temperature

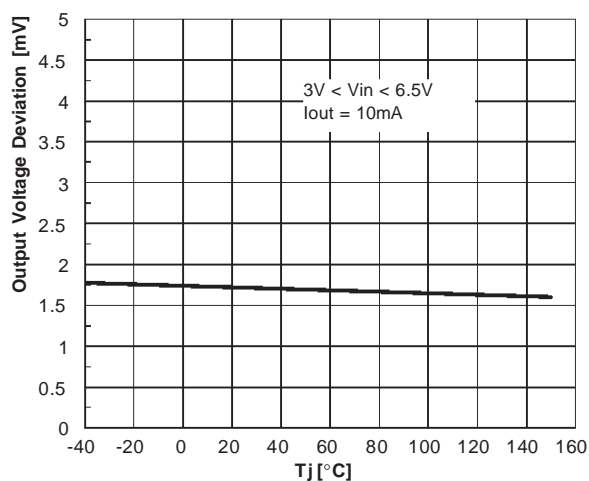

Figure 2: Load Regulation

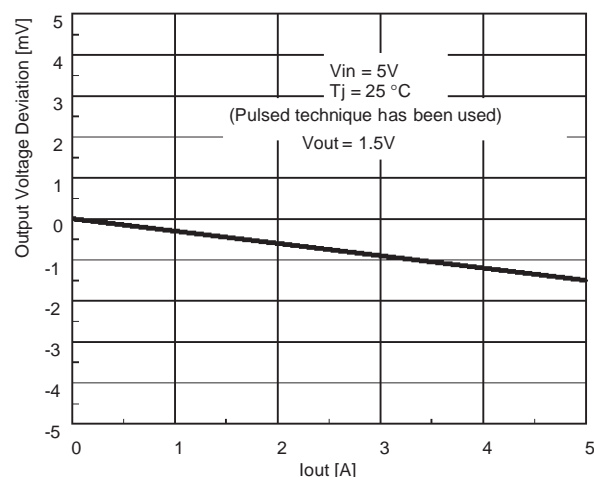

Figure 3: Maximum Output Current vs. Junction Temperature

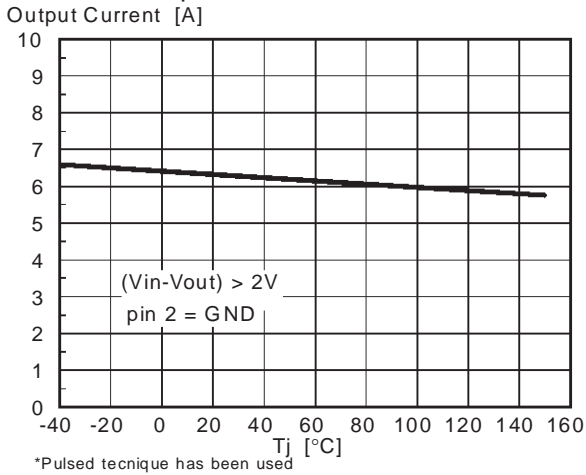

Figure 4: DC Operating Area

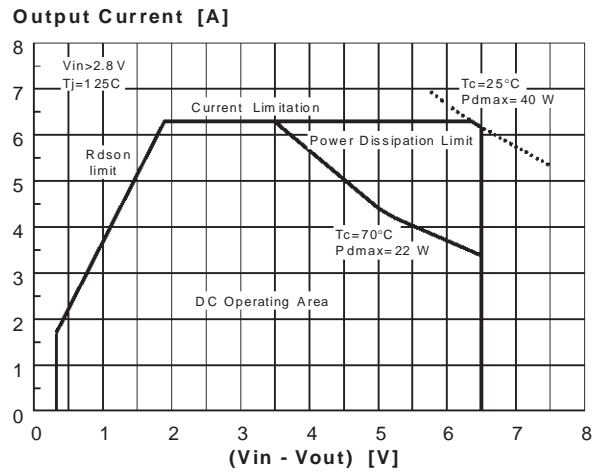

Figure 5: Ripple Rejection vs. Frequency

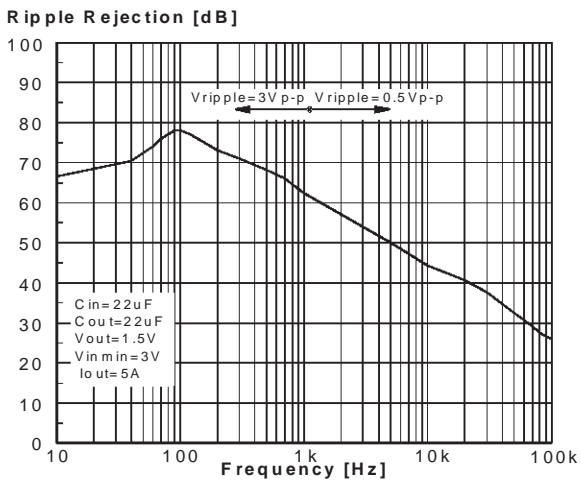

Figure 6: Output Voltage vs. Output Current. (VOUT = 1.5V)

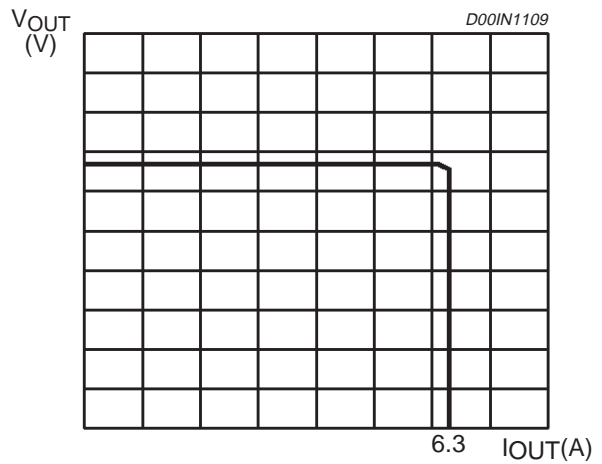
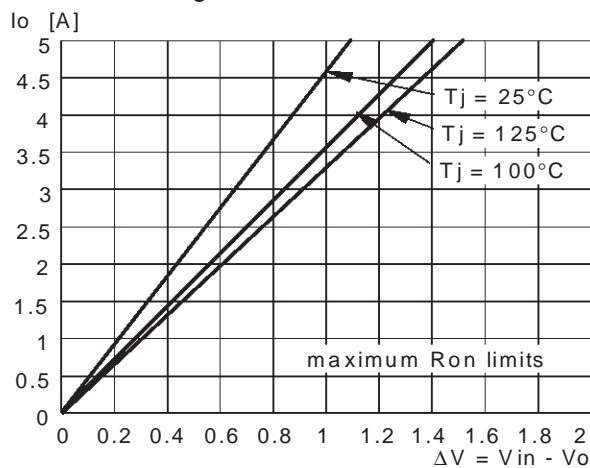
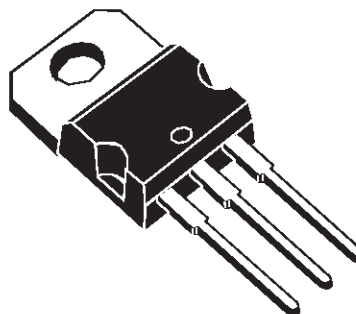

Figure 7: Maximum Output Current vs. Drop-Out Voltage



DIM.	mm			inch		
	MIN.	TYP.	MAX.	MIN.	TYP.	MAX.
A	4.40		4.60	0.173		0.181
C	1.23		1.32	0.048		0.051
D	2.40		2.72	0.094		0.107
E	0.49		0.70	0.019		0.027
F	0.61		0.88	0.024		0.034
F1	1.14		1.70	0.044		0.067
F2	1.14		1.70	0.044		0.067
G	4.95		5.15	0.194		0.203
G1	2.40		2.70	0.094		0.106
H2	10.0		10.4	0.393		0.409
L2		16.4			0.645	
L4	13.0		14.0	0.511		0.551
L5	2.65		2.95	0.104		0.116
L6	15.25		15.75	0.600		0.620
L7	6.20		6.60	0.244		0.260
L9	3.50		3.93	0.137		0.154
M		2.6			0.102	
Dia	3.75		3.85	0.147		0.151

OUTLINE AND MECHANICAL DATA



Versawatt (TO220)

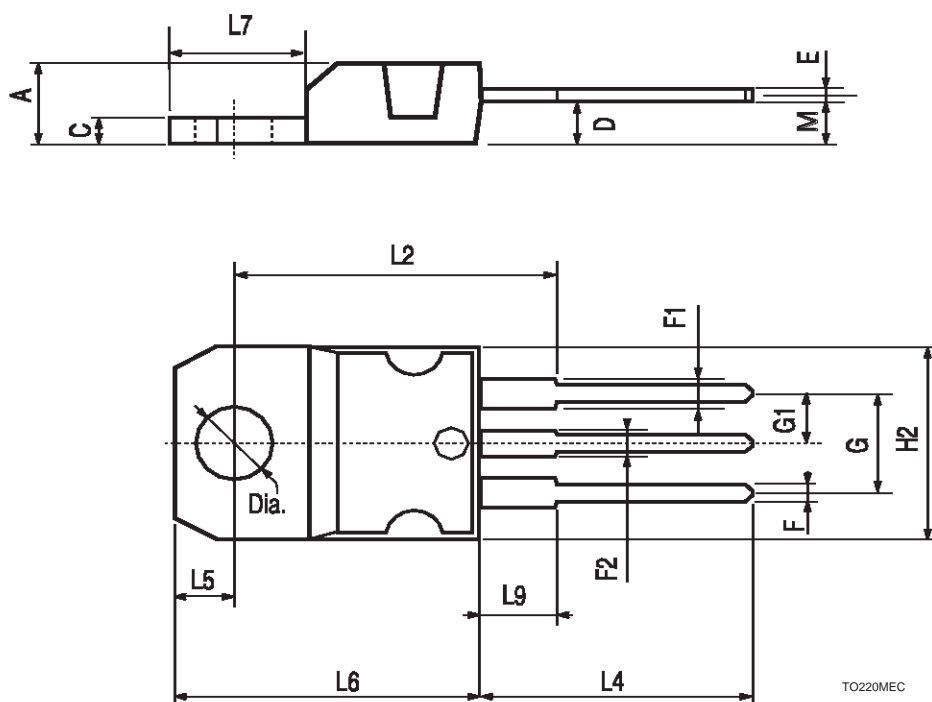

L4957A

REF.	DIMENSIONS					
	Millimeters			Inches		
	Min.	Typ.	Max.	Min.	Typ.	Max.
A	4.30		4.60	0.169		0.181
A1	2.49		2.69	0.098		0.106
A2	0.03		0.23	0.001		0.009
B	0.70		0.93	0.027		0.037
B2	1.25	1.40		0.049	0.055	
C	0.45		0.60	0.017		0.024
C2	1.21		1.36	0.047		0.054
D	8.95		9.35	0.352		0.368
E	10.00		10.28	0.393		0.405
G	4.88		5.28	0.192		0.208
L	15.00		15.85	0.590		0.624
L2	1.27		1.40	0.050		0.055
L3	1.40		1.75	0.055		0.069
R		0.40			0.016	
V2	0°		8°	0°		8°

OUTLINE AND MECHANICAL DATA

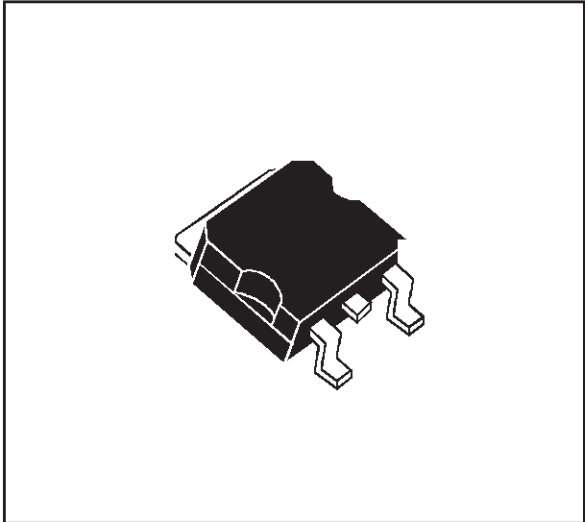

D²PAK

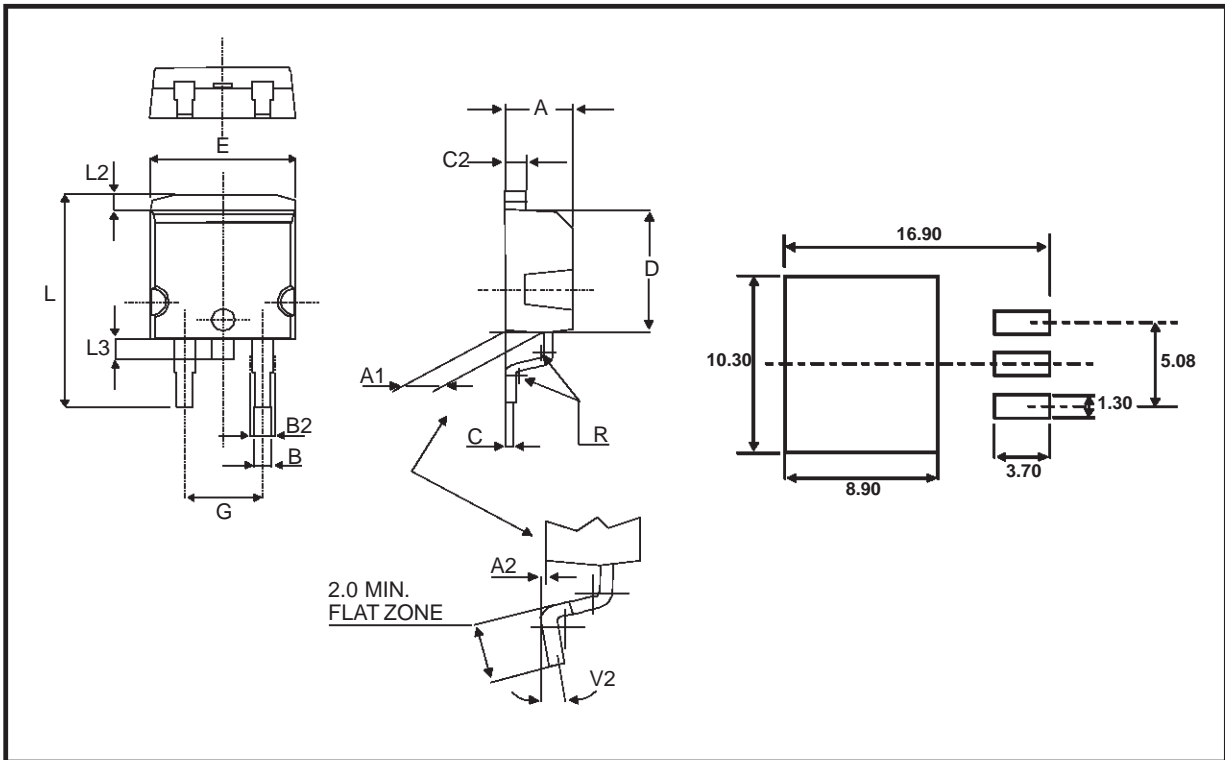

Information furnished is believed to be accurate and reliable. However, STMicroelectronics assumes no responsibility for the consequences of use of such information nor for any infringement of patents or other rights of third parties which may result from its use. No license is granted by implication or otherwise under any patent or patent rights of STMicroelectronics. Specification mentioned in this publication are subject to change without notice. This publication supersedes and replaces all information previously supplied. STMicroelectronics products are not authorized for use as critical components in life support devices or systems without express written approval of STMicroelectronics.

The ST logo is a registered trademark of STMicroelectronics

© 2000 STMicroelectronics – Printed in Italy – All Rights Reserved

STMicroelectronics GROUP OF COMPANIES

Australia - Brazil - China - Finland - France - Germany - Hong Kong - India - Italy - Japan - Malaysia - Malta - Morocco -
Singapore - Spain - Sweden - Switzerland - United Kingdom - U.S.A.

<http://www.st.com>