



LD1117A/B SERIES

LOW DROP FIXED AND ADJUSTABLE POSITIVE VOLTAGE REGULATORS

PRELIMINARY DATA

- LOW DROPOUT VOLTAGE
(1.15V TYP @ $I_{OUT}=1.2A$, 25 °C)
- VERY LOW QUIESCENT CURRENT
(5mA TYP @ 25 °C)
- TYPE A: OUTPUT CURRENT UP TO 1000mA
- TYPE B: OUTPUT CURRENT UP TO 1200mA
- FIXED OUTPUT VOLTAGE OF: 1.8V, 2.5V,
2.85V, 3.3V, 5.0V
- ADJUSTABLE VERSION AVAILABILITY
($V_{ref}=1.25V$)
- INTERNAL CURRENT AND THERMAL LIMIT
- ONLY 10 μF FOR STABILITY
- AVAILABLE IN $\pm 2\%$ (AT 25°C) AND 4% IN
FULL TEMPERATURE RANGE
- HIGH SUPPLY VOLTAGE REJECTION :
(80dB TYP)
- TEMPERATURE RANGE : 0°C TO 125°C

DESCRIPTION

The LD1117A and LD1117B are two LOW DROP Voltage Regulator able to provide respectively up to 1000mA and 1200mA of Output Current, available even in adjustable version ($V_{ref}=1.25V$). Concerning fixed versions, are offered the following Output Voltages: 1.8V, 2.5V, 2.85V, 3.3V and 5.0V. The 2.85V type is ideal for SCSI-2 lines active termination. The device is supplied in: SOT-223, DPAK. The

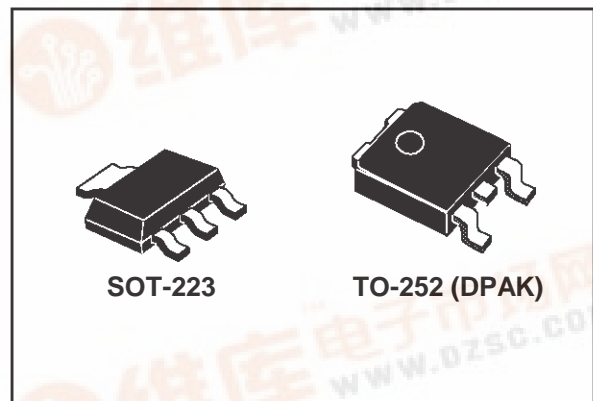

SOT-223 and DPAK surface mount packages optimize the thermal characteristics even offering a relevant space saving effect. High efficiency is assured by NPN pass transistor. In fact in this case, unlike than PNP one, the Quiescent Current flows mostly into the load. Only a very common 10 μF minimum capacitor is needed for stability. The ADJUSTABLE LD1117 is pin to pin compatible with the other standard Adjustable voltage regulators maintaining the better performances in terms of Drop and Tolerance.

BLOCK DIAGRAM

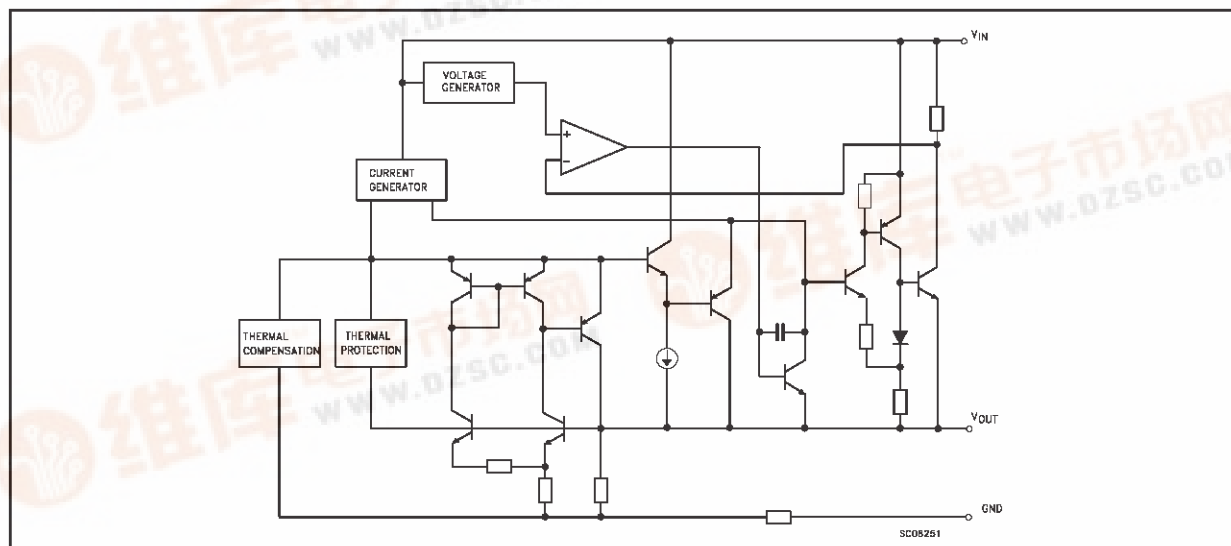

LD1117A/B SERIES

ABSOLUTE MAXIMUM RATINGS

Symbol	Parameter	Value	Unit
V_{IN}	DC Input Voltage	10	V
P_{tot}	Power Dissipation	12	W
T_{stg}	Storage Temperature Range	-40 to 150	°C
T_{op}	Operating Junction Temperature Range	0 to 125	°C

Absolute Maximum Ratings are those value beyond which damage to the device may occur. Functional operation under these condition is not implied. Over the above suggested Max Power Dissipation a Short Circuit could definitively damage the device.

THERMAL DATA

Symbol	Parameter	SOT-223	DKPAK	Unit
$R_{thj-case}$	Thermal Resistance Junction-case	15	8	°C/W

APPLICATION CIRCUIT

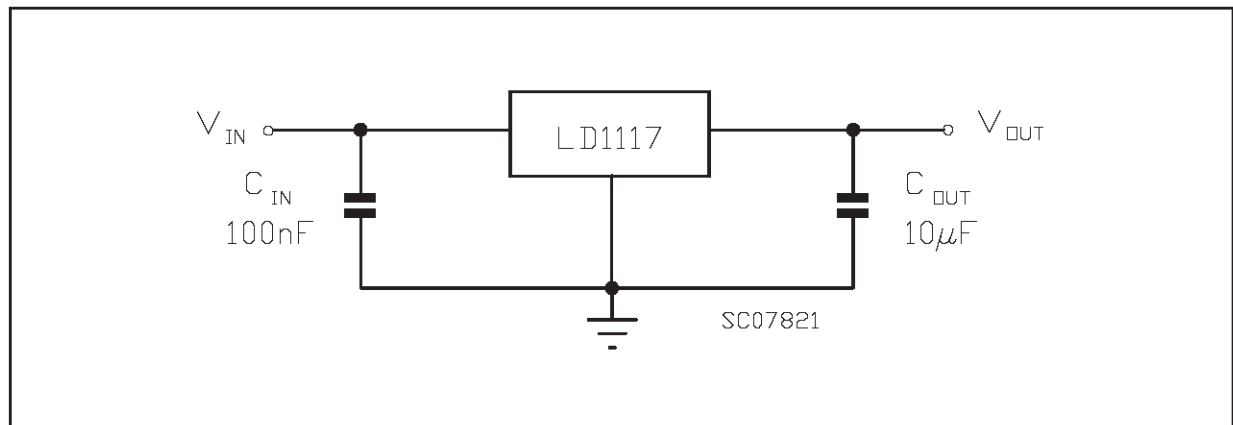

CONNECTION DIAGRAM AND ORDERING NUMBERS (top view)

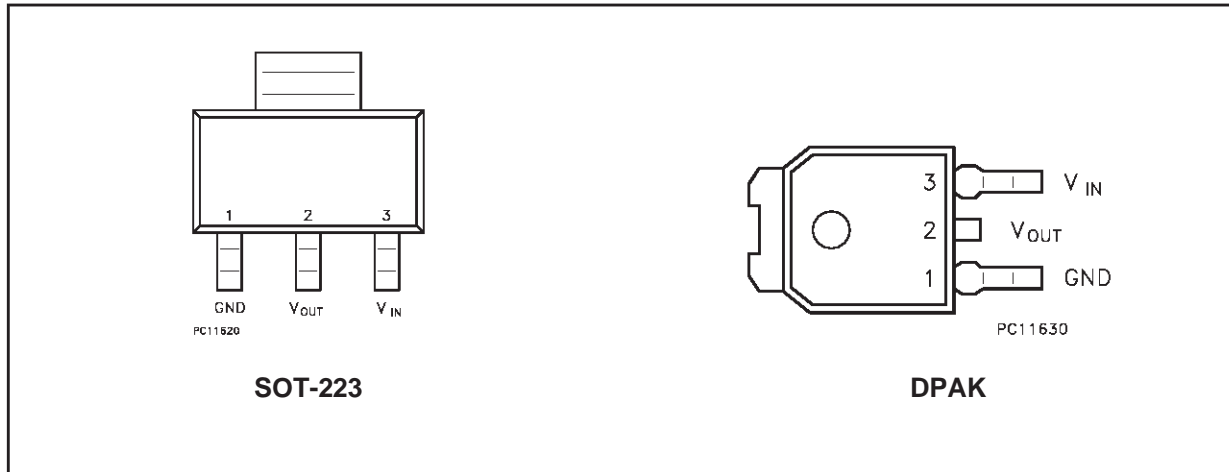

SOT-223	DPAK	Output Voltage
LD1117AS18TR	LD1117ADT18TR	1.8V
LD1117BS18TR	LD1117BDT18TR	1.8V
LD1117AS25TR	LD1117ADT25TR	2.5V
LD1117BS25TR	LD1117BDT25TR	2.5V
LD1117AS28TR	LD1117ADT28TR	2.85V
LD1117BS28TR	LD1117BDT28TR	2.85V
LD1117AS33TR	LD1117ADT33TR	3.3V
LD1117BS33TR	LD1117BDT33TR	3.3V
LD1117AS50TR	LD1117ADT50TR	5V
LD1117BS50TR	LD1117BDT50TR	5V
LD1117AST-R	LD1117ADT-R	ADJUSTABLE
LD1117BST-R	LD1117BDT-R	FROM 1.25 TO 15V

LD1117A/B SERIES

ELECTRICAL CHARACTERISTICS FOR LD1117A#18 (refer to the test circuits,
 $T_j = 0$ to 125 °C, $C_O = 10$ μ F, $C_I = 10$ μ F unless otherwise specified)

Symbol	Parameter	Test Conditions	Min.	Typ.	Max.	Unit
V_O	Output Voltage	$V_I = 3.8$ V $I_O = 10$ mA $T_j = 25$ °C	1.764	1.8	1.836	V
V_O	Output Voltage	$I_O = 0$ to 1000 mA $V_I = 3.3$ to 8 V	1.728		1.872	V
ΔV_O	Line Regulation	$V_I = 3.3$ to 8 V $I_O = 0$ mA		1	6	mV
ΔV_O	Load Regulation	$V_I = 3.3$ V $I_O = 0$ to 1000 mA		1	10	mV
V_I	Operating Input Voltage	$I_O = 100$ mA			10	V
I_d	Quiescent Current	$V_I \leq 8$ V $I_O = 0$ mA		5	10	mA
I_O	Output Current	$V_I - V_O = 5$ V $T_j = 25$ °C	1000	1200		mA
SVR	Supply Voltage Rejection	$I_O = 40$ mA $f = 120$ Hz $V_I - V_O = 3$ V $V_{ripple} = 1$ Vpp	60	80		dB
V_D	Dropout Voltage	$I_O = 100$ mA $I_O = 500$ mA $I_O = 1000$ mA		1 1.05 1.15	1.10 1.15 1.30	V V V
$\Delta V_{O(pwr)}$	Thermal Regulation	$T_a = 25$ °C 30ms Pulse		0.08	0.2	%/W

ELECTRICAL CHARACTERISTICS FOR LD1117B#18 (refer to the test circuits,
 $T_j = 0$ to 125 °C, $C_O = 10$ μ F, $C_I = 10$ μ F unless otherwise specified)

Symbol	Parameter	Test Conditions	Min.	Typ.	Max.	Unit
V_O	Output Voltage	$V_I = 3.8$ V $I_O = 10$ mA $T_j = 25$ °C	1.764	1.8	1.836	V
V_O	Output Voltage	$I_O = 0$ to 1200 mA $V_I = 3.3$ to 8 V	1.728		1.872	V
ΔV_O	Line Regulation	$V_I = 3.3$ to 8 V $I_O = 0$ mA		1	6	mV
ΔV_O	Load Regulation	$V_I = 3.3$ V $I_O = 0$ to 1200 mA		1	10	mV
V_I	Operating Input Voltage	$I_O = 100$ mA			10	V
I_d	Quiescent Current	$V_I \leq 8$ V $I_O = 0$ mA		5	10	mA
I_O	Output Current	$V_I - V_O = 5$ V $T_j = 25$ °C	1200	1500		mA
SVR	Supply Voltage Rejection	$I_O = 40$ mA $f = 120$ Hz $V_I - V_O = 3$ V $V_{ripple} = 1$ Vpp	60	80		dB
V_D	Dropout Voltage	$I_O = 100$ mA $I_O = 500$ mA $I_O = 1200$ mA		1 1.05 1.15	1.10 1.15 1.30	V V V
$\Delta V_{O(pwr)}$	Thermal Regulation	$T_a = 25$ °C 30ms Pulse		0.08	0.2	%/W

ELECTRICAL CHARACTERISTICS FOR LD1117A#25 (refer to the test circuits,
 $T_j = 0$ to 125 °C, $C_O = 10$ μ F, $C_I = 10$ μ F unless otherwise specified)

Symbol	Parameter	Test Conditions	Min.	Typ.	Max.	Unit
V_O	Output Voltage	$V_I = 4.5$ V $I_O = 10$ mA $T_j = 25$ °C	2.45	2.5	2.55	V
V_O	Output Voltage	$I_O = 0$ to 1000 mA $V_I = 3.9$ to 8 V	2.4		2.6	V
ΔV_O	Line Regulation	$V_I = 3.9$ to 8 V $I_O = 0$ mA		1	6	mV
ΔV_O	Load Regulation	$V_I = 3.9$ V $I_O = 0$ to 1000 mA		1	10	mV
V_I	Operating Input Voltage	$I_O = 100$ mA			10	V
I_d	Quiescent Current	$V_I \leq 10$ V $I_O = 0$ mA		5	10	mA
I_O	Output Current	$V_I - V_O = 5$ V $T_j = 25$ °C	1000	1200		mA
SVR	Supply Voltage Rejection	$I_O = 40$ mA $f = 120$ Hz $V_I - V_O = 3$ V $V_{ripple} = 1$ Vpp	60	80		dB
V_D	Dropout Voltage	$I_O = 100$ mA		1	1.10	V
		$I_O = 500$ mA		1.05	1.15	V
		$I_O = 1000$ mA		1.15	1.30	V
$\Delta V_{O(pwr)}$	Thermal Regulation	$T_a = 25$ °C 30ms Pulse		0.08	0.2	%/W

ELECTRICAL CHARACTERISTICS FOR LD1117B#25 (refer to the test circuits,
 $T_j = 0$ to 125 °C, $C_O = 10$ μ F, $C_I = 10$ μ F unless otherwise specified)

Symbol	Parameter	Test Conditions	Min.	Typ.	Max.	Unit
V_O	Output Voltage	$V_I = 4.5$ V $I_O = 10$ mA $T_j = 25$ °C	2.45	2.5	2.55	V
V_O	Output Voltage	$I_O = 0$ to 1200 mA $V_I = 3.9$ to 8 V	2.4		2.6	V
ΔV_O	Line Regulation	$V_I = 3.9$ to 8 V $I_O = 0$ mA		1	6	mV
ΔV_O	Load Regulation	$V_I = 3.9$ V $I_O = 0$ to 1200 mA		1	10	mV
V_I	Operating Input Voltage	$I_O = 100$ mA			10	V
I_d	Quiescent Current	$V_I \leq 10$ V $I_O = 0$ mA		5	10	mA
I_O	Output Current	$V_I - V_O = 5$ V $T_j = 25$ °C	1200	1500		mA
SVR	Supply Voltage Rejection	$I_O = 40$ mA $f = 120$ Hz $V_I - V_O = 3$ V $V_{ripple} = 1$ Vpp	60	80		dB
V_D	Dropout Voltage	$I_O = 100$ mA		1	1.10	V
		$I_O = 500$ mA		1.05	1.15	V
		$I_O = 1200$ mA		1.15	1.30	V
$\Delta V_{O(pwr)}$	Thermal Regulation	$T_a = 25$ °C 30ms Pulse		0.08	0.2	%/W

LD1117A/B SERIES

ELECTRICAL CHARACTERISTICS FOR LD1117A#28 (refer to the test circuits,

$T_j = 0$ to 125 °C, $C_O = 10$ μ F, $C_I = 10$ μ F unless otherwise specified)

Symbol	Parameter	Test Conditions	Min.	Typ.	Max.	Unit
V_O	Output Voltage	$V_I = 4.85$ V $I_O = 10$ mA $T_j = 25$ °C	2.793	2.85	2.907	V
V_O	Output Voltage	$I_O = 0$ to 1000 mA $V_I = 4.25$ to 10 V	2.736		2.964	V
ΔV_O	Line Regulation	$V_I = 4.25$ to 8 V $I_O = 0$ mA		1	6	mV
ΔV_O	Load Regulation	$V_I = 4.25$ V $I_O = 0$ to 1000 mA		2	10	mV
V_I	Operating Input Voltage	$I_O = 100$ mA			10	V
I_d	Quiescent Current	$V_I \leq 10$ V $I_O = 0$ mA		4.5	10	mA
I_O	Output Current	$V_I - V_O = 5$ V $T_j = 25$ °C	1000	1200		mA
SVR	Supply Voltage Rejection	$I_O = 40$ mA $f = 120$ Hz $V_I - V_O = 3$ V $V_{ripple} = 1$ Vpp	60	75		dB
V_D	Dropout Voltage	$I_O = 100$ mA		1	1.10	V
		$I_O = 500$ mA		1.05	1.15	V
		$I_O = 1000$ mA		1.15	1.30	V
$\Delta V_{O(pwr)}$	Thermal Regulation	$T_a = 25$ °C 30ms Pulse		0.08	0.2	%/W

ELECTRICAL CHARACTERISTICS FOR LD1117B#28 (refer to the test circuits,

$T_j = 0$ to 125 °C, $C_O = 10$ μ F, $C_I = 10$ μ F unless otherwise specified)

Symbol	Parameter	Test Conditions	Min.	Typ.	Max.	Unit
V_O	Output Voltage	$V_I = 4.85$ V $I_O = 10$ mA $T_j = 25$ °C	2.793	2.85	2.907	V
V_O	Output Voltage	$I_O = 0$ to 1200 mA $V_I = 4.25$ to 10 V	2.736		2.964	V
ΔV_O	Line Regulation	$V_I = 4.25$ to 10 V $I_O = 0$ mA		1	6	mV
ΔV_O	Load Regulation	$V_I = 4.25$ V $I_O = 0$ to 1200 mA		2	10	mV
V_I	Operating Input Voltage	$I_O = 100$ mA			10	V
I_d	Quiescent Current	$V_I \leq 10$ V $I_O = 0$ mA		4.5	10	mA
I_O	Output Current	$V_I - V_O = 5$ V $T_j = 25$ °C	1200	1500		mA
SVR	Supply Voltage Rejection	$I_O = 40$ mA $f = 120$ Hz $V_I - V_O = 3$ V $V_{ripple} = 1$ Vpp	60	75		dB
V_D	Dropout Voltage	$I_O = 100$ mA		1	1.10	V
		$I_O = 500$ mA		1.05	1.15	V
		$I_O = 1200$ mA		1.15	1.30	V
$\Delta V_{O(pwr)}$	Thermal Regulation	$T_a = 25$ °C 30ms Pulse		0.08	0.2	%/W

ELECTRICAL CHARACTERISTICS FOR LD1117A#33 (refer to the test circuits,
 $T_j = 0$ to $125\text{ }^\circ\text{C}$, $C_O = 10\text{ }\mu\text{F}$, $C_I = 10\text{ }\mu\text{F}$ unless otherwise specified)

Symbol	Parameter	Test Conditions	Min.	Typ.	Max.	Unit
V_O	Output Voltage	$V_I = 5.3\text{ V}$ $I_O = 10\text{ mA}$ $T_j = 25\text{ }^\circ\text{C}$	3.234	3.3	3.366	V
V_O	Output Voltage	$I_O = 0$ to 1000 mA $V_I = 4.75$ to 10 V	3.168		3.432	V
ΔV_O	Line Regulation	$V_I = 4.75$ to 8 V $I_O = 0\text{ mA}$		1	6	mV
ΔV_O	Load Regulation	$V_I = 4.75\text{ V}$ $I_O = 0$ to 1000 mA		1	10	mV
V_I	Operating Input Voltage	$I_O = 100\text{ mA}$			10	V
I_d	Quiescent Current	$V_I \leq 10\text{ V}$ $I_O = 0\text{ mA}$		5	10	mA
I_O	Output Current	$V_I - V_O = 5\text{ V}$ $T_j = 25\text{ }^\circ\text{C}$	1000	1200		mA
SVR	Supply Voltage Rejection	$I_O = 40\text{ mA}$ $f = 120\text{ Hz}$ $V_I - V_O = 3\text{ V}$ $V_{\text{ripple}} = 1\text{ Vpp}$	60	75		dB
V_D	Dropout Voltage	$I_O = 100\text{ mA}$ $I_O = 500\text{ mA}$ $I_O = 1000\text{ mA}$		1 1.05 1.15	1.10 1.15 1.30	V V V
$\Delta V_{O(\text{pwr})}$	Thermal Regulation	$T_a = 25\text{ }^\circ\text{C}$ 30ms Pulse		0.08	0.2	%/W

ELECTRICAL CHARACTERISTICS FOR LD1117B#33 (refer to the test circuits,
 $T_j = 0$ to $125\text{ }^\circ\text{C}$, $C_O = 10\text{ }\mu\text{F}$, $C_I = 10\text{ }\mu\text{F}$ unless otherwise specified)

Symbol	Parameter	Test Conditions	Min.	Typ.	Max.	Unit
V_O	Output Voltage	$V_I = 5.3\text{ V}$ $I_O = 10\text{ mA}$ $T_j = 25\text{ }^\circ\text{C}$	3.234	3.3	3.366	V
V_O	Output Voltage	$I_O = 0$ to 1200 mA $V_I = 4.75$ to 10 V	3.168		3.432	V
ΔV_O	Line Regulation	$V_I = 4.75$ to 10 V $I_O = 0\text{ mA}$		1	6	mV
ΔV_O	Load Regulation	$V_I = 4.75\text{ V}$ $I_O = 0$ to 1200 mA		1	10	mV
V_I	Operating Input Voltage	$I_O = 100\text{ mA}$			10	V
I_d	Quiescent Current	$V_I \leq 10\text{ V}$ $I_O = 0\text{ mA}$		5	10	mA
I_O	Output Current	$V_I - V_O = 5\text{ V}$ $T_j = 25\text{ }^\circ\text{C}$	1200	1500		mA
SVR	Supply Voltage Rejection	$I_O = 40\text{ mA}$ $f = 120\text{ Hz}$ $V_I - V_O = 3\text{ V}$ $V_{\text{ripple}} = 1\text{ Vpp}$	60	75		dB
V_D	Dropout Voltage	$I_O = 100\text{ mA}$ $I_O = 500\text{ mA}$ $I_O = 1200\text{ mA}$		1 1.05 1.15	1.10 1.15 1.30	V V V
$\Delta V_{O(\text{pwr})}$	Thermal Regulation	$T_a = 25\text{ }^\circ\text{C}$ 30ms Pulse		0.08	0.2	%/W

LD1117A/B SERIES

ELECTRICAL CHARACTERISTICS FOR LD1117A#50 (refer to the test circuits,

$T_j = 0$ to 125 °C, $C_O = 10$ μ F, $C_I = 10$ μ F unless otherwise specified)

Symbol	Parameter	Test Conditions	Min.	Typ.	Max.	Unit
V_O	Output Voltage	$V_I = 7$ V $I_O = 10$ mA $T_j = 25$ °C	4.9	5	5.1	V
V_O	Output Voltage	$I_O = 0$ to 1000 mA $V_I = 6.4$ to 10 V	4.8		5.2	V
ΔV_O	Line Regulation	$V_I = 6.4$ to 8 V $I_O = 0$ mA		1	6	mV
ΔV_O	Load Regulation	$V_I = 6.4$ V $I_O = 0$ to 1000 mA		1	10	mV
V_I	Operating Input Voltage	$I_O = 100$ mA			10	V
I_d	Quiescent Current	$V_I \leq 10$ V $I_O = 0$ mA		5	10	mA
I_O	Output Current	$V_I - V_O = 5$ V $T_j = 25$ °C	1000	1200		mA
SVR	Supply Voltage Rejection	$I_O = 40$ mA $f = 120$ Hz $V_I - V_O = 3$ V $V_{ripple} = 1$ Vpp	60	80		dB
V_D	Dropout Voltage	$I_O = 100$ mA $I_O = 500$ mA $I_O = 1000$ mA		1 1.05 1.15	1.10 1.15 1.30	V V V
$\Delta V_{O(pwr)}$	Thermal Regulation	$T_a = 25$ °C 30ms Pulse		0.08	0.2	%/W

ELECTRICAL CHARACTERISTICS FOR LD1117B#50 (refer to the test circuits,

$T_j = 0$ to 125 °C, $C_O = 10$ μ F, $C_I = 10$ μ F unless otherwise specified)

Symbol	Parameter	Test Conditions	Min.	Typ.	Max.	Unit
V_O	Output Voltage	$V_I = 7$ V $I_O = 10$ mA $T_j = 25$ °C	4.9	5	5.1	V
V_O	Output Voltage	$I_O = 0$ to 1200 mA $V_I = 6.4$ to 10 V	4.8		5.2	V
ΔV_O	Line Regulation	$V_I = 6.4$ to 10 V $I_O = 0$ mA		1	6	mV
ΔV_O	Load Regulation	$V_I = 6.4$ V $I_O = 0$ to 1200 mA		1	10	mV
V_I	Operating Input Voltage	$I_O = 100$ mA			10	V
I_d	Quiescent Current	$V_I \leq 10$ V $I_O = 0$ mA		5	10	mA
I_O	Output Current	$V_I - V_O = 5$ V $T_j = 25$ °C	1200	1500		mA
SVR	Supply Voltage Rejection	$I_O = 40$ mA $f = 120$ Hz $V_I - V_O = 3$ V $V_{ripple} = 1$ Vpp	60	80		dB
V_D	Dropout Voltage	$I_O = 100$ mA $I_O = 500$ mA $I_O = 1200$ mA		1 1.05 1.15	1.10 1.15 1.30	V V V
$\Delta V_{O(pwr)}$	Thermal Regulation	$T_a = 25$ °C 30ms Pulse		0.08	0.2	%/W

ELECTRICAL CHARACTERISTICS FOR LD1117ADJ (refer to the test circuits,
 $T_j = 0$ to $125\text{ }^\circ\text{C}$, $C_O = 10\text{ }\mu\text{F}$, $C_I = 10\text{ }\mu\text{F}$ unless otherwise specified)

Symbol	Parameter	Test Conditions	Min.	Typ.	Max.	Unit
V_O	Output Voltage	$V_I = 5.3\text{ V}$ $I_O = 10\text{ mA}$ $T_j = 25\text{ }^\circ\text{C}$	1.225	1.25	1.275	V
V_O	Output Voltage	$I_O = 0$ to 1000 mA $V_I = 2.75$ to 10 V	1.2		1.3	V
ΔV_O	Line Regulation	$V_I = 2.75$ to 10 V $I_O = 0\text{ mA}$		1	6	mV
ΔV_O	Load Regulation	$V_I = 2.75\text{ V}$ $I_O = 0$ to 1000 mA		1	10	mV
V_I	Operating Input Voltage	$I_O = 100\text{ mA}$			10	V
I_d	Quiescent Current	$V_I \leq 8\text{ V}$ $I_O = 0\text{ mA}$		5	10	mA
I_O	Output Current	$V_I - V_O = 5\text{ V}$ $T_j = 25\text{ }^\circ\text{C}$	1000	1200		mA
SVR	Supply Voltage Rejection	$I_O = 40\text{ mA}$ $f = 120\text{ Hz}$ $V_I - V_O = 3\text{ V}$ $V_{\text{ripple}} = 1\text{ Vpp}$	60	80		dB
V_D	Dropout Voltage	$I_O = 100\text{ mA}$ $I_O = 500\text{ mA}$ $I_O = 1000\text{ mA}$		1 1.05 1.15	1.10 1.15 1.30	V V V
$\Delta V_{O(\text{pwr})}$	Thermal Regulation	$T_a = 25\text{ }^\circ\text{C}$ 30ms Pulse		0.08	0.2	%/W

ELECTRICAL CHARACTERISTICS FOR LD1117BDJ (refer to the test circuits,
 $T_j = 0$ to $125\text{ }^\circ\text{C}$, $C_O = 10\text{ }\mu\text{F}$, $C_I = 10\text{ }\mu\text{F}$ unless otherwise specified)

Symbol	Parameter	Test Conditions	Min.	Typ.	Max.	Unit
V_O	Output Voltage	$V_I = 5.3\text{ V}$ $I_O = 10\text{ mA}$ $T_j = 25\text{ }^\circ\text{C}$	1.225	1.25	1.275	V
V_O	Output Voltage	$I_O = 0$ to 1200 mA $V_I = 2.75$ to 10 V	1.2		1.3	V
ΔV_O	Line Regulation	$V_I = 2.75$ to 10 V $I_O = 0\text{ mA}$		1	6	mV
ΔV_O	Load Regulation	$V_I = 2.75\text{ V}$ $I_O = 0$ to 1200 mA		1	10	mV
V_I	Operating Input Voltage	$I_O = 100\text{ mA}$			10	V
I_d	Quiescent Current	$V_I \leq 8\text{ V}$ $I_O = 0\text{ mA}$		5	10	mA
I_O	Output Current	$V_I - V_O = 5\text{ V}$ $T_j = 25\text{ }^\circ\text{C}$	1200	1500		mA
SVR	Supply Voltage Rejection	$I_O = 40\text{ mA}$ $f = 120\text{ Hz}$ $V_I - V_O = 3\text{ V}$ $V_{\text{ripple}} = 1\text{ Vpp}$	60	80		dB
V_D	Dropout Voltage	$I_O = 100\text{ mA}$ $I_O = 500\text{ mA}$ $I_O = 1200\text{ mA}$		1 1.05 1.15	1.10 1.15 1.30	V V V
$\Delta V_{O(\text{pwr})}$	Thermal Regulation	$T_a = 25\text{ }^\circ\text{C}$ 30ms Pulse		0.08	0.2	%/W

LD1117A/B SERIES

TYPICAL APPLICATIONS:

FIGURE 1: Negative Supply

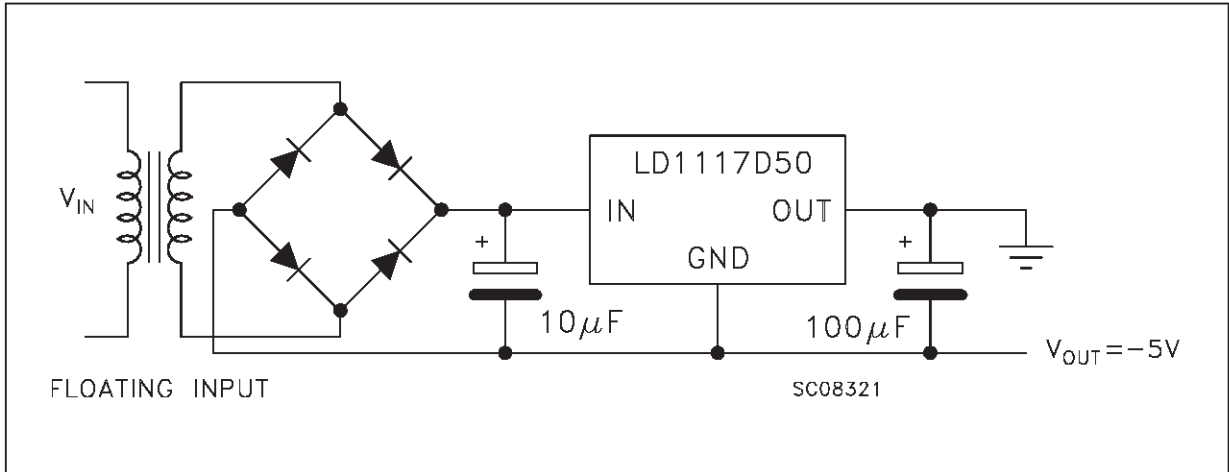

FIGURE 2: Active Terminator for SCSI-2 BUS

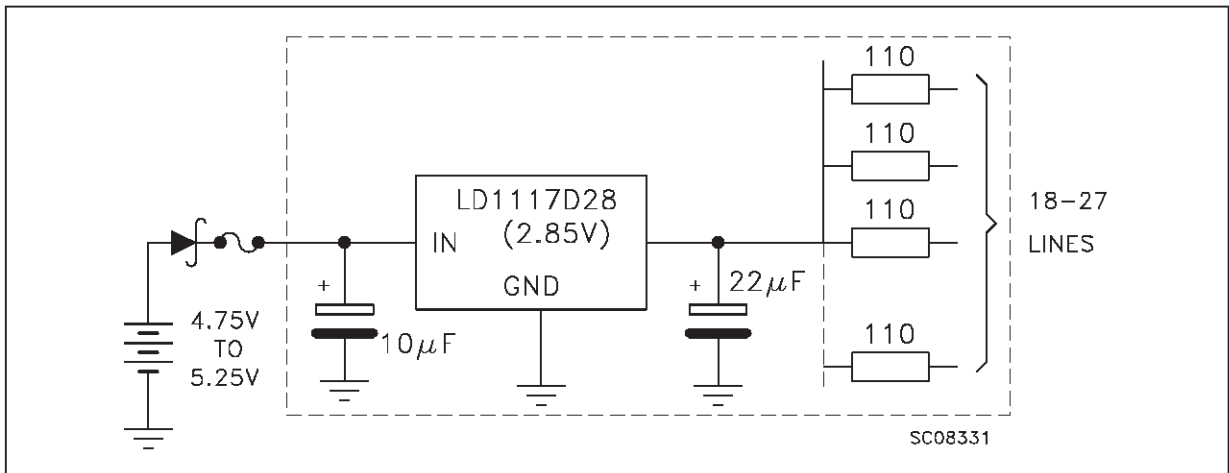
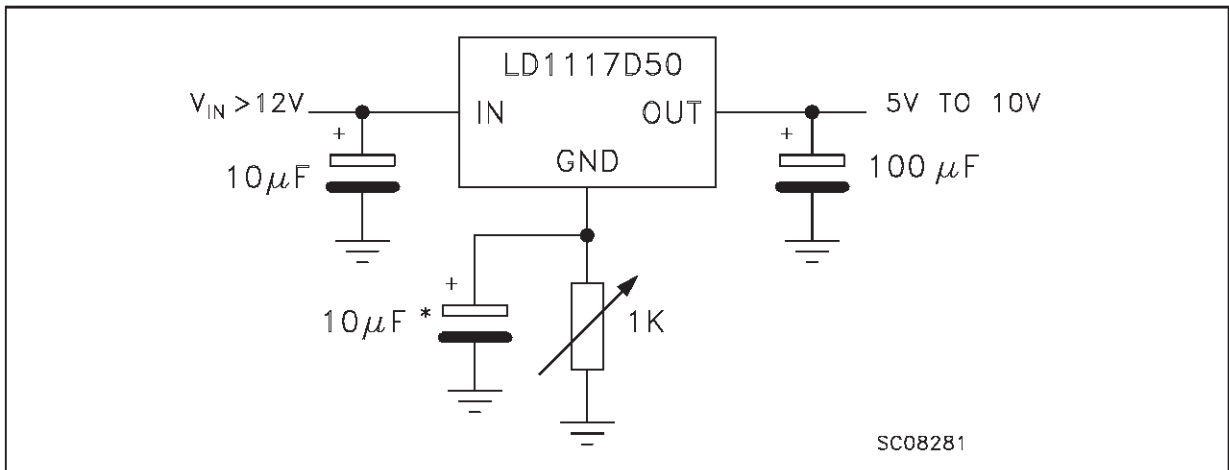

FIGURE 3: Circuit for Increasing Output Voltage



TYPICAL APPLICATIONS (continued):

FIGURE 4: Voltage Regulator With Reference

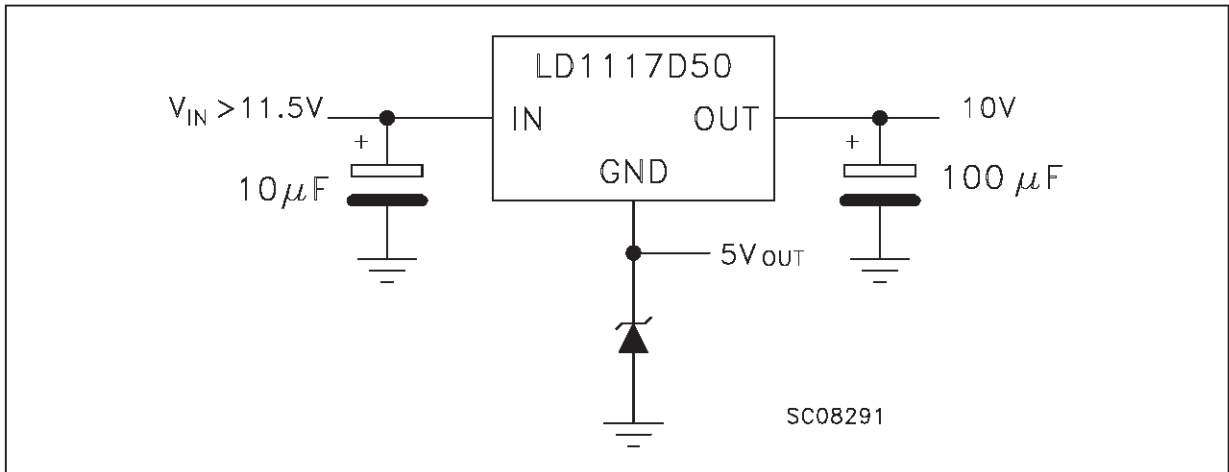
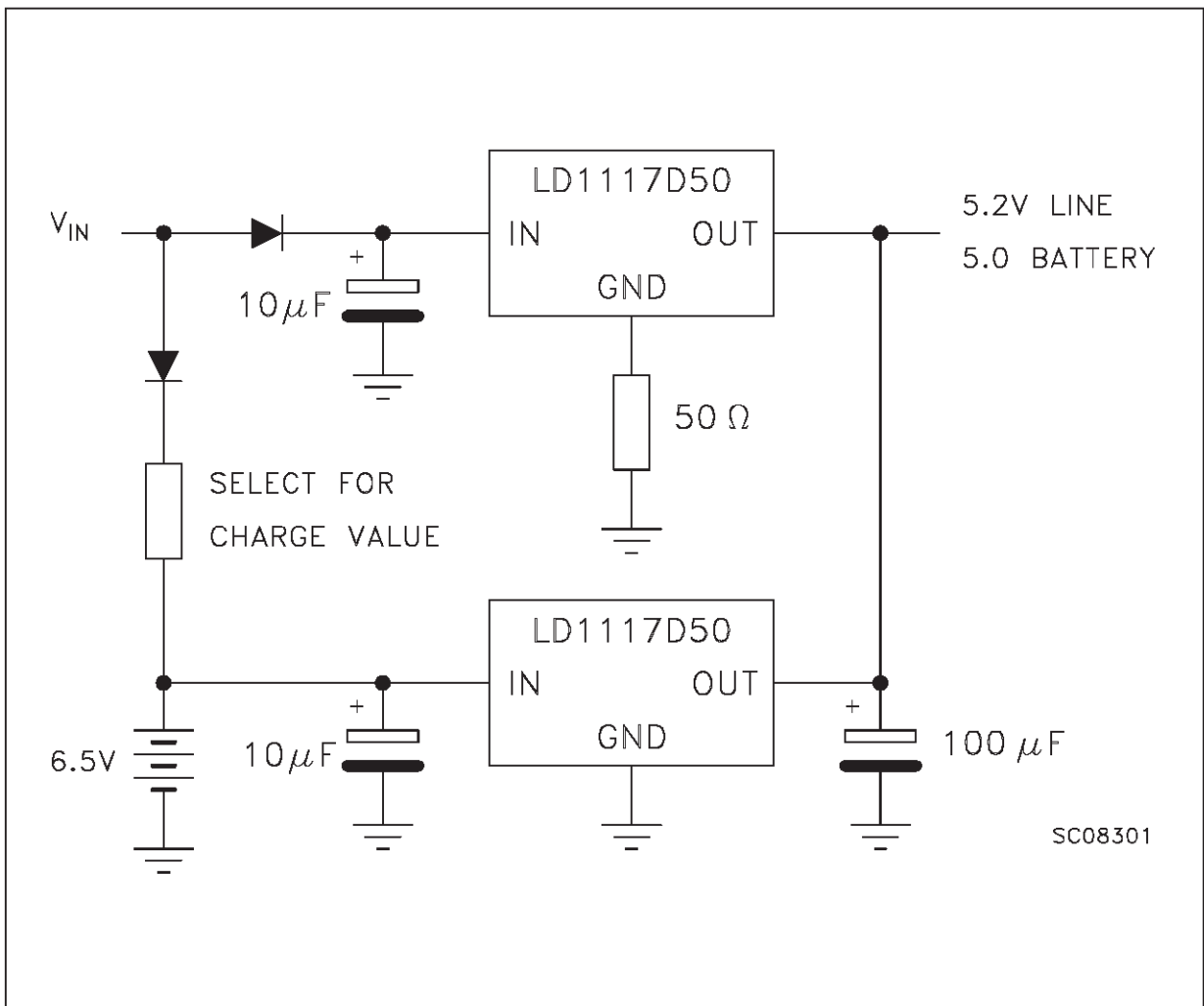

FIGURE 5: Battery Backed-up Regulated Supply



LD1117A/B SERIES

TYPICAL APPLICATIONS (continued):

FIGURE 6: Post-Regulated Dual Supply

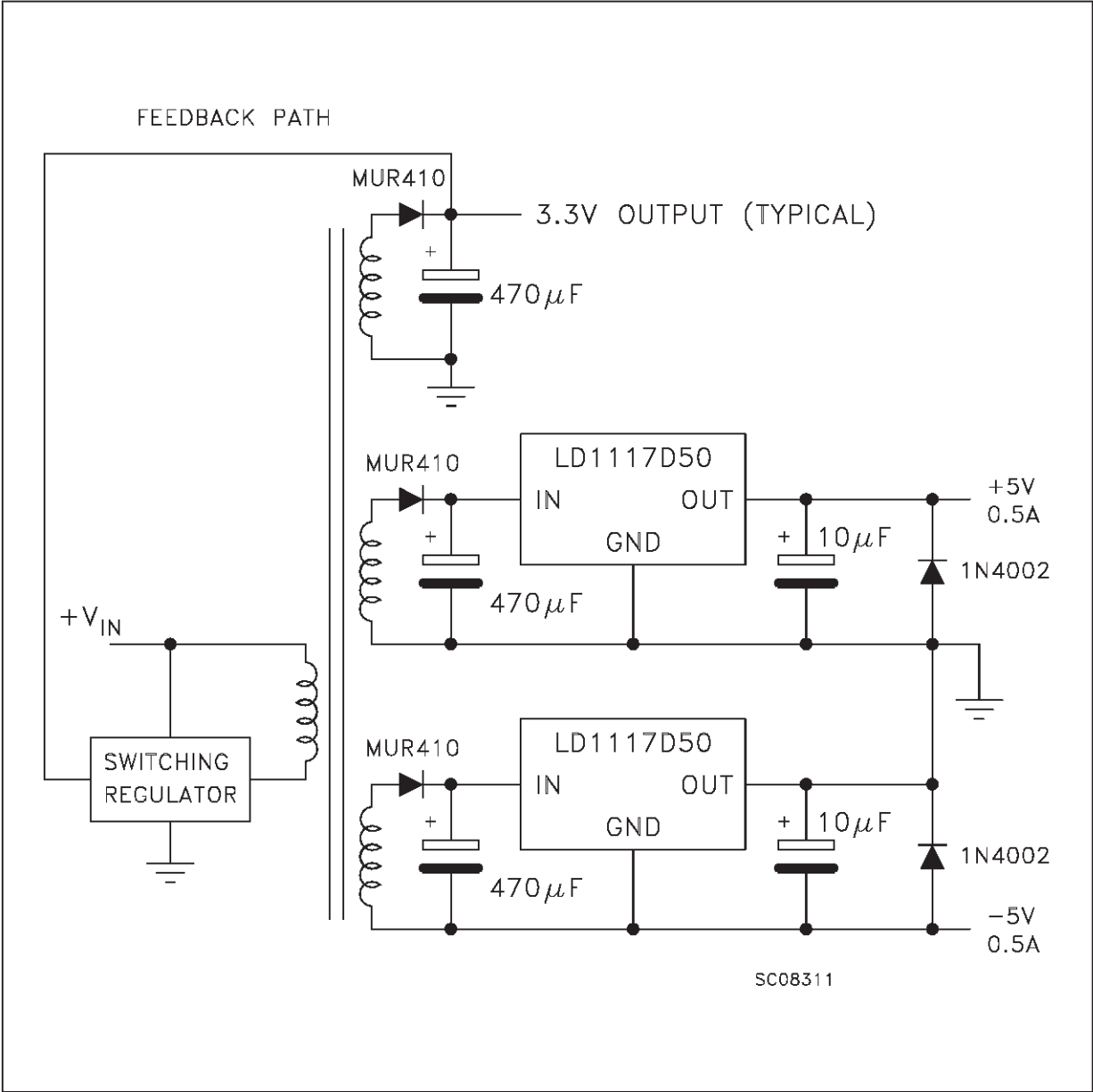

LD1117 ADJUSTABLE: APPLICATION NOTE

The LD1117 ADJUSTABLE has a thermal stabilized $1.25 \pm 0.012V$ reference voltage between the OUT and ADJ pins. I_{ADJ} is $60\mu A$ typ. ($120\mu A$ max.) and ΔI_{ADJ} is $1\mu A$ typ. ($5\mu A$ max.).

$R1$ is normally fixed to 120Ω . From figure 7 we obtain:

$$V_{OUT} = V_{REF} + R2 (I_{ADJ} + I_{R1}) = V_{REF} + R2 (I_{ADJ} + V_{REF} / R1) = V_{REF} (1 + R2 / R1) + R2 \times I_{ADJ}.$$

In normal application $R2$ value is in the range of few Kohm, so the $R2 \times I_{DJ}$ product could not be considered in the V_{OUT} calculation; then the above expression becomes:

$$V_{OUT} = V_{REF} (1 + R2 / R1).$$

In order to have the better load regulation it is important to realize a good Kelvin connection of $R1$ and $R2$ resistors. In particular $R1$ connection must be realized very close to OUT and ADJ pin, while $R2$ ground connection must be placed as near as possible to the negative Load pin. Ripple rejection can be improved by introducing a $10\mu F$ electrolytic capacitor placed in parallel to the $R2$ resistor (see Fig.8)

FIGURE 7: Adjustable Output Voltage Application Circuit

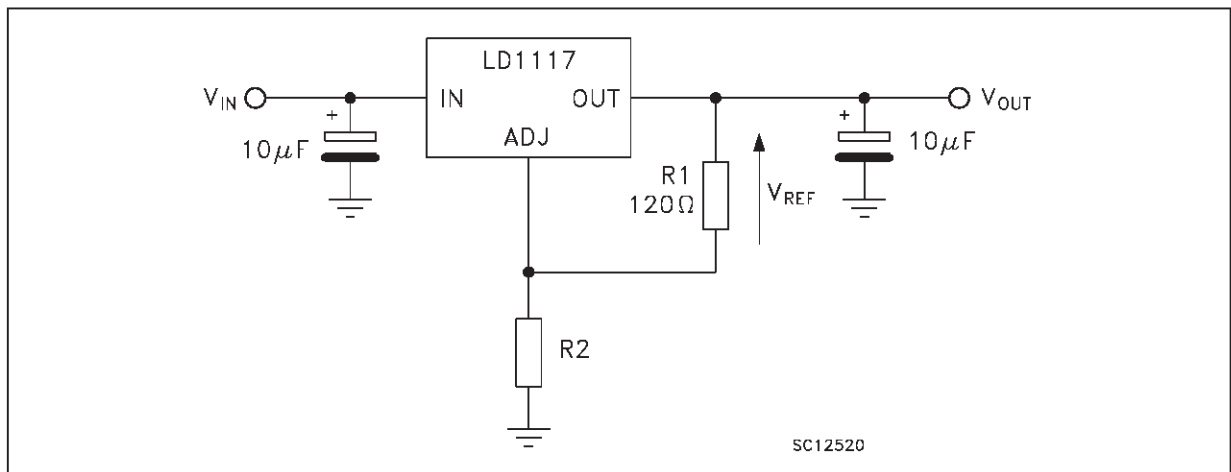
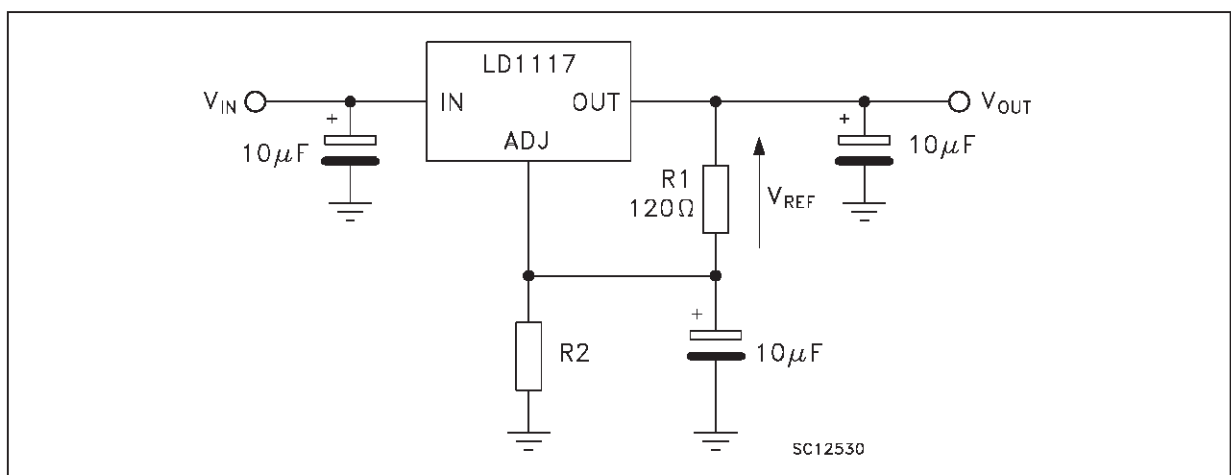

FIGURE 8: Adjustable Output Voltage Application with improved Ripple Rejection



LD1117A/B SERIES

SOT-223 MECHANICAL DATA

DIM.	mm			mils		
	MIN.	TYP.	MAX.	MIN.	TYP.	MAX.
a	2.27	2.3	2.33	89.4	90.6	91.7
b	4.57	4.6	4.63	179.9	181.1	182.3
c	0.2	0.4	0.6	7.9	15.7	23.6
d	0.63	0.65	0.67	24.8	25.6	26.4
e1	1.5	1.6	1.7	59.1	63	66.9
e4			0.32			12.6
f	2.9	3	3.1	114.2	118.1	122.1
g	0.67	0.7	0.73	26.4	27.6	28.7
l1	6.7	7	7.3	263.8	275.6	287.4
l2	3.5	3.5	3.7	137.8	137.8	145.7
L	6.3	6.5	6.7	248	255.9	263.8

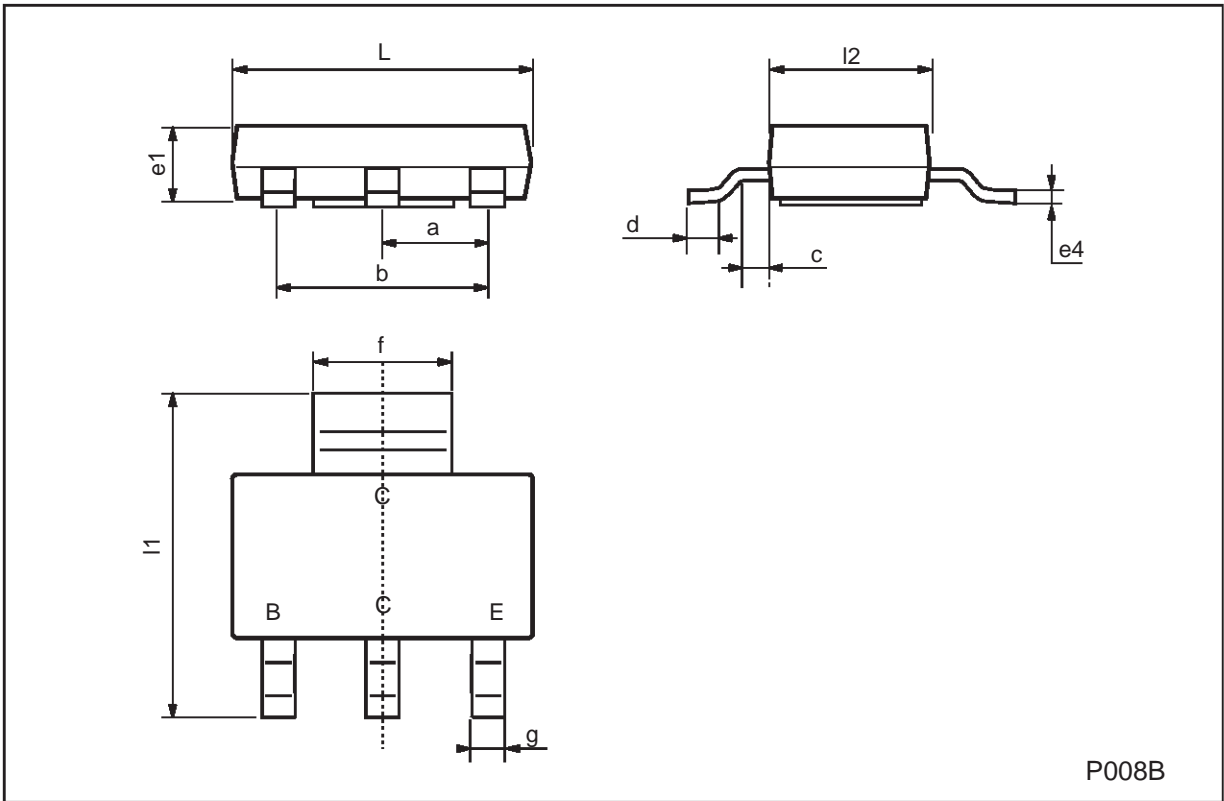

TO-252 (DPAK) MECHANICAL DATA

DIM.	mm			inch		
	MIN.	TYP.	MAX.	MIN.	TYP.	MAX.
A	2.2		2.4	0.086		0.094
A1	0.9		1.1	0.035		0.043
A2	0.03		0.23	0.001		0.009
B	0.64		0.9	0.025		0.035
B2	5.2		5.4	0.204		0.212
C	0.45		0.6	0.017		0.023
C2	0.48		0.6	0.019		0.023
D	6		6.2	0.236		0.244
E	6.4		6.6	0.252		0.260
G	4.4		4.6	0.173		0.181
H	9.35		10.1	0.368		0.397
L2		0.8			0.031	
L4	0.6		1	0.023		0.039

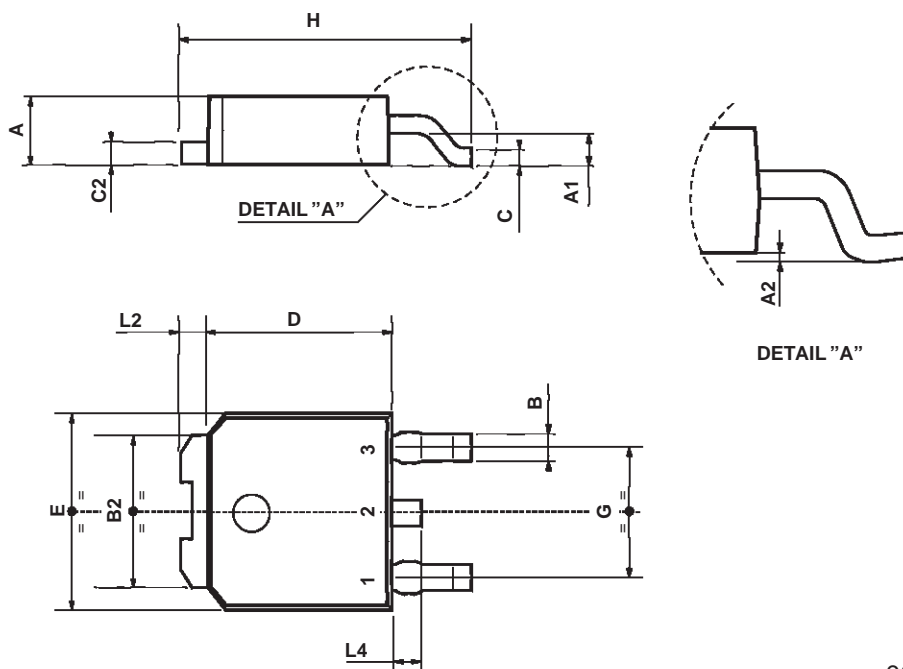

0068772-B

LD1117A/B SERIES

Information furnished is believed to be accurate and reliable. However, STMicroelectronics assumes no responsibility for the consequences of use of such information nor for any infringement of patents or other rights of third parties which may result from its use. No license is granted by implication or otherwise under any patent or patent rights of STMicroelectronics. Specification mentioned in this publication are subject to change without notice. This publication supersedes and replaces all information previously supplied. STMicroelectronics products are not authorized for use as critical components in life support devices or systems without express written approval of STMicroelectronics.

The ST logo is a registered trademark of STMicroelectronics

© 2000 STMicroelectronics – Printed in Italy – All Rights Reserved

STMicroelectronics GROUP OF COMPANIES

Australia - Brazil - China - Finland - France - Germany - Hong Kong - India - Italy - Japan - Malaysia - Malta - Morocco
Singapore - Spain - Sweden - Switzerland - United Kingdom - U.S.A.

<http://www.st.com>