

MC14527B

BCD Rate Multiplier

The MC14527B BCD rate multiplier (DRM) provides an output pulse rate based upon the BCD input number. For example, if 6 is the BCD input number, there will be six output pulses for every ten input pulses. This part may be used for arithmetic operations including multiplication and division. Typical applications include digital filters, motor speed control and frequency synthesizers.

- Supply Voltage Range = 3.0 Vdc to 18 Vdc
- Output Clocked on the Negative Going Edge of Clock
- Strobe for Inhibiting or Enabling Outputs
- Enable and Cascade Inputs for Cascade Operation of Two or More DRMs
- "9" Output for the Parallel Enable Configuration and DRMs in Cascade
- Complementary Outputs
- Clear and Set to Nine Inputs

MAXIMUM RATINGS* (Voltages Referenced to V_{SS})

| Symbol | Parameter | Value | Unit |
|------------------------------------|--|--------------------------------|------|
| V _{DD} | DC Supply Voltage | - 0.5 to + 18.0 | V |
| V _{in} , V _{out} | Input or Output Voltage (DC or Transient) | - 0.5 to V _{DD} + 0.5 | V |
| I _{in} , I _{out} | Input or Output Current (DC or Transient), per Pin | ± 10 | mA |
| P _D | Power Dissipation, per Package† | 500 | mW |
| T _{stg} | Storage Temperature | - 65 to + 150 | °C |
| T _L | Lead Temperature (8-Second Soldering) | 260 | °C |

* Maximum Ratings are those values beyond which damage to the device may occur.

† Temperature Derating:

Plastic "P and D/DW" Packages: - 7.0 mW/°C From 65°C To 125°C

Ceramic "L" Packages: - 12 mW/°C From 100°C To 125°C

TRUTH TABLE (X = Don't Care, *D = Most Significant Bit)

| Inputs | | | | | | | | | | Output | | | |
|--------|---|---|---|---------------------|----------------|--------|---------|-------|-----|------------------|-------------|------------------|-----|
| | | | | | | | | | | Logic Level | | | |
| | | | | | | | | | | Number of Pulses | | | |
| D* | C | B | A | No. of Clock Pulses | \bar{E}_{in} | Strobe | Cascade | Clear | Set | Out | \bar{Out} | E _{Out} | "9" |
| 0 | 0 | 0 | 0 | 10 | 0 | 0 | 0 | 0 | 0 | 0 | 1 | 1 | 1 |
| 0 | 0 | 0 | 1 | 10 | 0 | 0 | 0 | 0 | 0 | 1 | 1 | 1 | 1 |
| 0 | 0 | 1 | 0 | 10 | 0 | 0 | 0 | 0 | 0 | 2 | 2 | 1 | 1 |
| 0 | 0 | 1 | 1 | 10 | 0 | 0 | 0 | 0 | 0 | 3 | 3 | 1 | 1 |
| 0 | 1 | 0 | 0 | 10 | 0 | 0 | 0 | 0 | 0 | 4 | 4 | 1 | 1 |
| 0 | 1 | 0 | 1 | 10 | 0 | 0 | 0 | 0 | 0 | 5 | 5 | 1 | 1 |
| 0 | 1 | 1 | 0 | 10 | 0 | 0 | 0 | 0 | 0 | 6 | 6 | 1 | 1 |
| 0 | 1 | 1 | 1 | 10 | 0 | 0 | 0 | 0 | 0 | 7 | 7 | 1 | 1 |
| 1 | 0 | 0 | 0 | 10 | 0 | 0 | 0 | 0 | 0 | 8 | 8 | 1 | 1 |
| 1 | 0 | 0 | 1 | 10 | 0 | 0 | 0 | 0 | 0 | 9 | 9 | 1 | 1 |
| 1 | 0 | 1 | 0 | 10 | 0 | 0 | 0 | 0 | 0 | 8 | 8 | 1 | 1 |
| 1 | 0 | 1 | 1 | 10 | 0 | 0 | 0 | 0 | 0 | 9 | 9 | 1 | 1 |
| 1 | 1 | 0 | 0 | 10 | 0 | 0 | 0 | 0 | 0 | 8 | 8 | 1 | 1 |
| 1 | 1 | 0 | 1 | 10 | 0 | 0 | 0 | 0 | 0 | 9 | 9 | 1 | 1 |
| 1 | 1 | 1 | 0 | 10 | 0 | 0 | 0 | 0 | 0 | 8 | 8 | 1 | 1 |
| 1 | 1 | 1 | 1 | 10 | 0 | 0 | 0 | 0 | 0 | 9 | 9 | 1 | 1 |
| X | X | X | X | 10 | 1 | 0 | 0 | 0 | 0 | — | — | — | — |
| X | X | X | X | 10 | 0 | 1 | 0 | 0 | 0 | 0 | 1 | 1 | 1 |
| X | X | X | X | 10 | 0 | 0 | 1 | 0 | 0 | 1 | 0 | 1 | 1 |
| 1 | X | X | X | 10 | 0 | 0 | 0 | 1 | 0 | 10 | 10 | 1 | 0 |
| 0 | X | X | X | 10 | 0 | 0 | 0 | 1 | 0 | 0 | 1 | 1 | 0 |
| 0 | X | X | X | 10 | 0 | 0 | 0 | 0 | 1 | 0 | 1 | 0 | 1 |

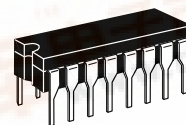

L SUFFIX
 CERAMIC
 CASE 620

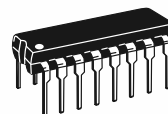

P SUFFIX
 PLASTIC
 CASE 648

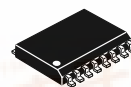

DW SUFFIX
 SOIC
 CASE 751G

ORDERING INFORMATION

MC14XXXBCP Plastic
 MC14XXXBCL Ceramic
 MC14XXXBDW SOIC

T_A = - 55° to 125°C for all packages.

BLOCK DIAGRAM

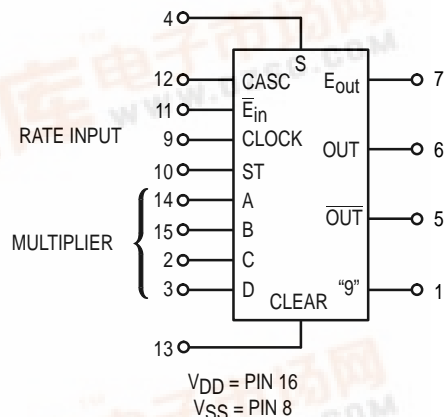

ELECTRICAL CHARACTERISTICS (Voltages Referenced to V_{SS})

| Characteristic | Symbol | V_{DD} Vdc | - 55 °C | | 25 °C | | | 125 °C | | Unit |
|---|-----------------------|-----------------|-------------------------------------|-----------|--------|---------------|-----------|--------|-----------|-----------|
| | | | Min | Max | Min | Typ # | Max | Min | Max | |
| Output Voltage $V_{in} = V_{DD}$ or 0 $V_{in} = 0$ or V_{DD} | "0" Level V_{OL} | 5.0 | — | 0.05 | — | 0 | 0.05 | — | 0.05 | Vdc |
| | | 10 | — | 0.05 | — | 0 | 0.05 | — | 0.05 | |
| | | 15 | — | 0.05 | — | 0 | 0.05 | — | 0.05 | |
| | "1" Level V_{OH} | 5.0 | 4.95 | — | 4.95 | 5.0 | — | 4.95 | — | Vdc |
| | | 10 | 9.95 | — | 9.95 | 10 | — | 9.95 | — | |
| | | 15 | 14.95 | — | 14.95 | 15 | — | 14.95 | — | |
| Input Voltage ($V_O = 4.5$ or 0.5 Vdc) ($V_O = 9.0$ or 1.0 Vdc) ($V_O = 13.5$ or 1.5 Vdc) ($V_O = 0.5$ or 4.5 Vdc) ($V_O = 1.0$ or 9.0 Vdc) ($V_O = 1.5$ or 13.5 Vdc) | "0" Level V_{IL} | 5.0 | — | 1.5 | — | 2.25 | 1.5 | — | 1.5 | Vdc |
| | | 10 | — | 3.0 | — | 4.50 | 3.0 | — | 3.0 | |
| | | 15 | — | 4.0 | — | 6.75 | 4.0 | — | 4.0 | |
| | "1" Level V_{IH} | 5.0 | 3.5 | — | 3.5 | 2.75 | — | 3.5 | — | Vdc |
| | | 10 | 7.0 | — | 7.0 | 5.50 | — | 7.0 | — | |
| | | 15 | 11 | — | 11 | 8.25 | — | 11 | — | |
| Output Drive Current ($V_{OH} = 2.5$ Vdc) ($V_{OH} = 4.6$ Vdc) ($V_{OH} = 9.5$ Vdc) ($V_{OH} = 13.5$ Vdc) ($V_{OL} = 0.4$ Vdc) ($V_{OL} = 0.5$ Vdc) ($V_{OL} = 1.5$ Vdc) | Source I_{OH} | 5.0 | - 3.0 | — | - 2.4 | - 4.2 | — | - 1.7 | — | mAdc |
| | | 5.0 | - 0.64 | — | - 0.51 | - 0.88 | — | - 0.36 | — | |
| | | 10 | - 1.6 | — | - 1.3 | - 2.25 | — | - 0.9 | — | |
| | | 15 | - 4.2 | — | - 3.4 | - 8.8 | — | - 2.4 | — | |
| | Sink I_{OL} | 5.0 | 0.64 | — | 0.51 | 0.88 | — | 0.36 | — | mAdc |
| | | 10 | 1.6 | — | 1.3 | 2.25 | — | 0.9 | — | |
| 15 | 4.2 | — | 3.4 | 8.8 | — | 2.4 | — | — | | |
| Input Current | I_{in} | 15 | — | ± 0.1 | — | ± 0.00001 | ± 0.1 | — | ± 1.0 | μ Adc |
| Input Capacitance ($V_{in} = 0$) | C_{in} | — | — | — | — | 5.0 | 7.5 | — | — | pF |
| Quiescent Current (Per Package) | I_{DD} | 5.0 | — | 5.0 | — | 0.005 | 5.0 | — | 150 | μ Adc |
| | | 10 | — | 10 | — | 0.010 | 10 | — | 300 | |
| | | 15 | — | 20 | — | 0.015 | 20 | — | 600 | |
| Total Supply Current**† (Dynamic plus Quiescent, Per Package) ($C_L = 50$ pF on all outputs, all buffers switching) | I_T | 5.0 | $I_T = (0.85 \mu A/kHz) f + I_{DD}$ | | | | | | | μ Adc |
| | | 10 | $I_T = (1.75 \mu A/kHz) f + I_{DD}$ | | | | | | | |
| | | 15 | $I_T = (2.60 \mu A/kHz) f + I_{DD}$ | | | | | | | |

#Data labelled "Typ" is not to be used for design purposes but is intended as an indication of the IC's potential performance.

**The formulas given are for the typical characteristics only at 25 °C.

†To calculate total supply current at loads other than 50 pF:

$$I_T(C_L) = I_T(50 \text{ pF}) + (C_L - 50) Vfk$$

where: I_T is in μA (per package), C_L in pF, $V = (V_{DD} - V_{SS})$ in volts, f in kHz is input frequency, and $k = 0.0012$.

This device contains protection circuitry to guard against damage due to high static voltages or electric fields. However, precautions must be taken to avoid applications of any voltage higher than maximum rated voltages to this high-impedance circuit. For proper operation, V_{in} and V_{out} should be constrained to the range $V_{SS} \leq (V_{in} \text{ or } V_{out}) \leq V_{DD}$. Unused inputs must always be tied to an appropriate logic voltage level (e.g., either V_{SS} or V_{DD}). Unused outputs must be left open.

PIN ASSIGNMENT

| | | | |
|-----------|-----|----|----------------|
| "g" | 1 ● | 16 | V_{DD} |
| C | 2 | 15 | B |
| D | 3 | 14 | A |
| S | 4 | 13 | CLEAR |
| OUT | 5 | 12 | CASC |
| OUT | 6 | 11 | \bar{E}_{in} |
| E_{out} | 7 | 10 | ST |
| V_{SS} | 8 | 9 | CLOCK |

SWITCHING CHARACTERISTICS* ($C_L = 50 \text{ pF}$, $T_A = 25^\circ\text{C}$)

| Characteristic | Symbol | V _{DD} | Min | Typ # | Max | Unit |
|--|--------------------------|-----------------|-------------------|--------------------|-------------------|---------------|
| Output Rise and Fall Time $t_{TLH}, t_{THL} = (1.5 \text{ ns/pF}) C_L + 25 \text{ ns}$ $t_{TLH}, t_{THL} = (0.75 \text{ ns/pF}) C_L + 12.5 \text{ ns}$ $t_{TLH}, t_{THL} = (0.55 \text{ ns/pF}) C_L + 9.5 \text{ ns}$ | t_{TLH} , t_{THL} | 5.0 10 15 | — — — | 100 50 40 | 200 100 80 | ns |
| Propagation Delay Time Clock to Out $t_{PLH}, t_{PHL} = (1.7 \text{ ns/pF}) C_L + 115 \text{ ns}$ $t_{PLH}, t_{PHL} = (0.66 \text{ ns/pF}) C_L + 67 \text{ ns}$ $t_{PLH}, t_{PHL} = (0.5 \text{ ns/pF}) C_L + 45 \text{ ns}$ Clock to $\overline{\text{Out}}$ $t_{PLH}, t_{PHL} = (1.7 \text{ ns/pF}) C_L + 40 \text{ ns}$ $t_{PLH}, t_{PHL} = (0.66 \text{ ns/pF}) C_L + 32 \text{ ns}$ $t_{PLH}, t_{PHL} = (0.5 \text{ ns/pF}) C_L + 20 \text{ ns}$ Clock to E _{out} $t_{PLH}, t_{PHL} = (1.7 \text{ ns/pF}) C_L + 210 \text{ ns}$ $t_{PLH}, t_{PHL} = (0.66 \text{ ns/pF}) C_L + 97 \text{ ns}$ $t_{PLH}, t_{PHL} = (0.5 \text{ ns/pF}) C_L + 60 \text{ ns}$ Clock to "g" $t_{PLH}, t_{PHL} = (1.7 \text{ ns/pF}) C_L + 315 \text{ ns}$ $t_{PLH}, t_{PHL} = (0.66 \text{ ns/pF}) C_L + 122 \text{ ns}$ $t_{PLH}, t_{PHL} = (0.5 \text{ ns/pF}) C_L + 85 \text{ ns}$ Set or Clear to Out $t_{PHL} = (1.7 \text{ ns/pF}) C_L + 295 \text{ ns}$ $t_{PHL} = (0.66 \text{ ns/pF}) C_L + 132 \text{ ns}$ $t_{PHL} = (0.5 \text{ ns/pF}) C_L + 85 \text{ ns}$ Cascade to Out $t_{PHL} = (1.7 \text{ ns/pF}) C_L + 40 \text{ ns}$ $t_{PHL} = (0.66 \text{ ns/pF}) C_L + 32 \text{ ns}$ $t_{PHL} = (0.5 \text{ ns/pF}) C_L + 20 \text{ ns}$ Strobe to Out $t_{PHL} = (1.7 \text{ ns/pF}) C_L + 145 \text{ ns}$ $t_{PHL} = (0.66 \text{ ns/pF}) C_L + 72 \text{ ns}$ $t_{PHL} = (0.5 \text{ ns/pF}) C_L + 45 \text{ ns}$ | t_{PHL} , t_{PHL} | 5.0 10 15 | — — — | 200 100 70 | 400 200 140 | ns |
| | t_{PLH} , t_{PHL} | 5.0 10 15 | — — — | 125 65 45 | 250 130 90 | ns |
| | t_{PLH} , t_{PHL} | 5.0 10 15 | — — — | 295 130 85 | 590 260 170 | ns |
| | t_{PLH} , t_{PHL} | 5.0 10 15 | — — — | 400 155 110 | 800 310 220 | ns |
| | t_{PHL} | 5.0 10 15 | — — — | 380 165 110 | 760 330 220 | ns |
| | t_{PLH} | 5.0 10 15 | — — — | 125 65 45 | 250 130 90 | ns |
| | t_{PLH} | 5.0 10 15 | — — — | 230 105 70 | 260 210 140 | ns |
| Clock Pulse Width | t_{WH} | 5.0 10 15 | 500 200 150 | 250 110 80 | — — — | ns |
| Clock Pulse Frequency | f_{cl} | 5.0 10 15 | — — — | 2.0 4.5 6.0 | 1.2 2.5 3.5 | MHz |
| Clock Pulse Rise and Fall Time | t_{TLH} , t_{THL} | 5.0 10 15 | — — — | — — — | 15 5 4 | μs |
| Set or Clear Pulse Width | t_{WH} | 5.0 10 15 | 240 100 75 | 80 35 30 | — — — | ns |
| Set Removal Time | t_{rem} | 5.0 10 15 | 0 0 0 | -20 -10 -7.5 | — — — | ns |
| Enable In Setup Time | t_{su} | 5.0 10 15 | 400 150 120 | 175 60 45 | — — — | ns |

* The formulas given are for the typical characteristics only at 25°C.

#Data labelled "Typ" is not to be used for design purposes but is intended as an indication of the IC's potential performance.

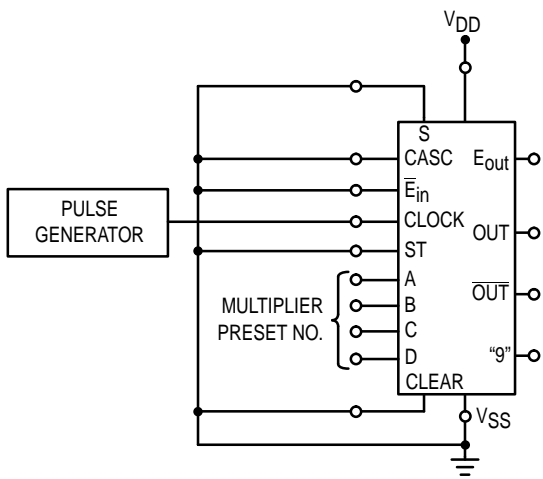

Figure 1. Test Circuit and Timing Diagram

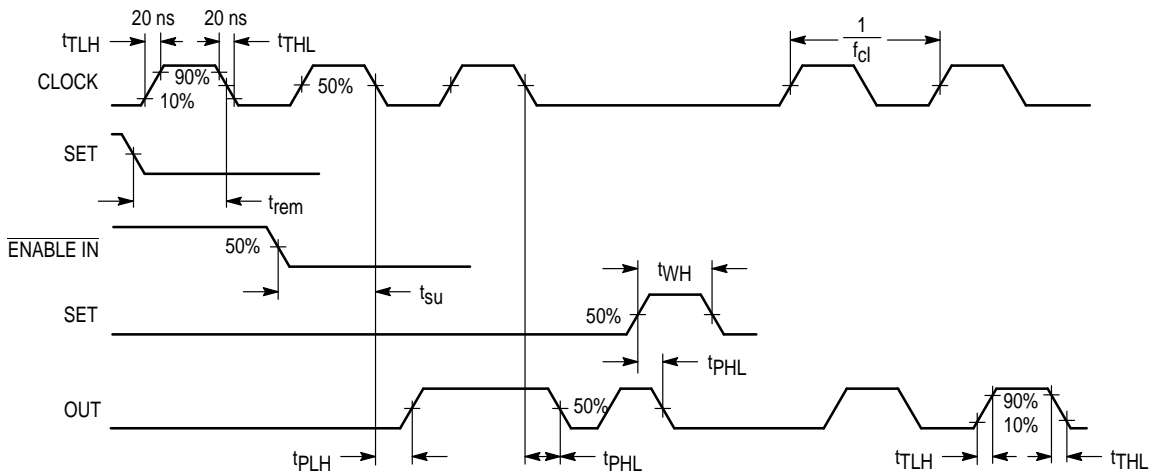
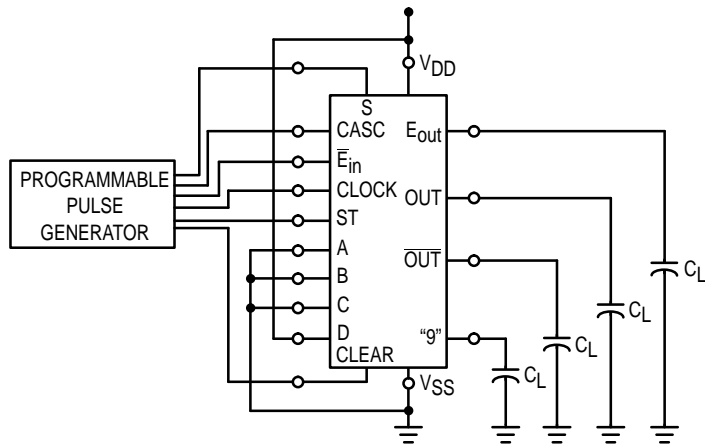

Figure 2. Switching Time Test Circuit and Waveforms

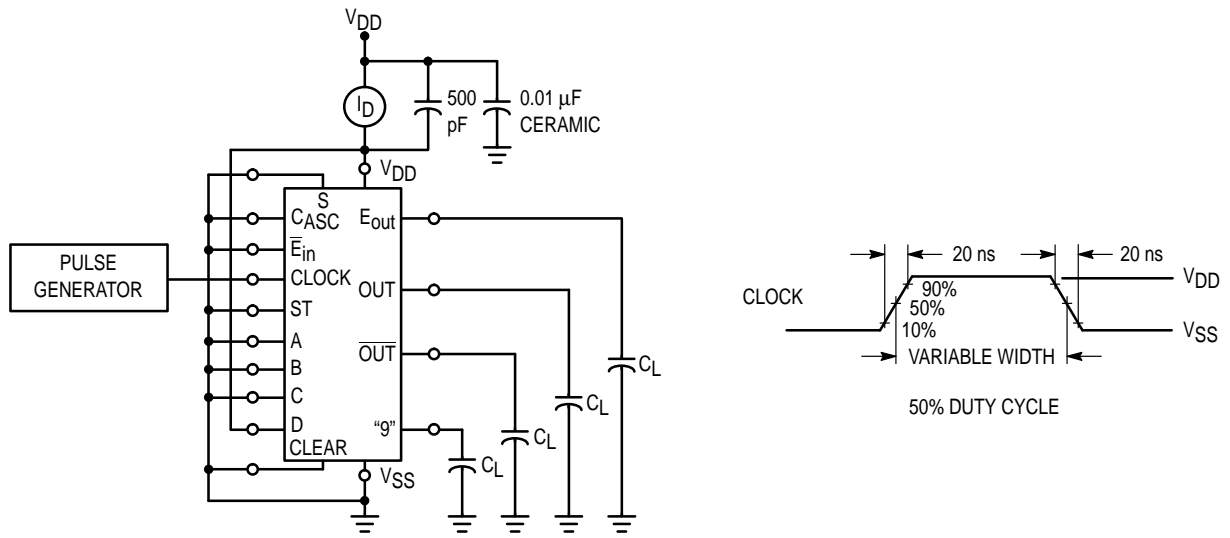
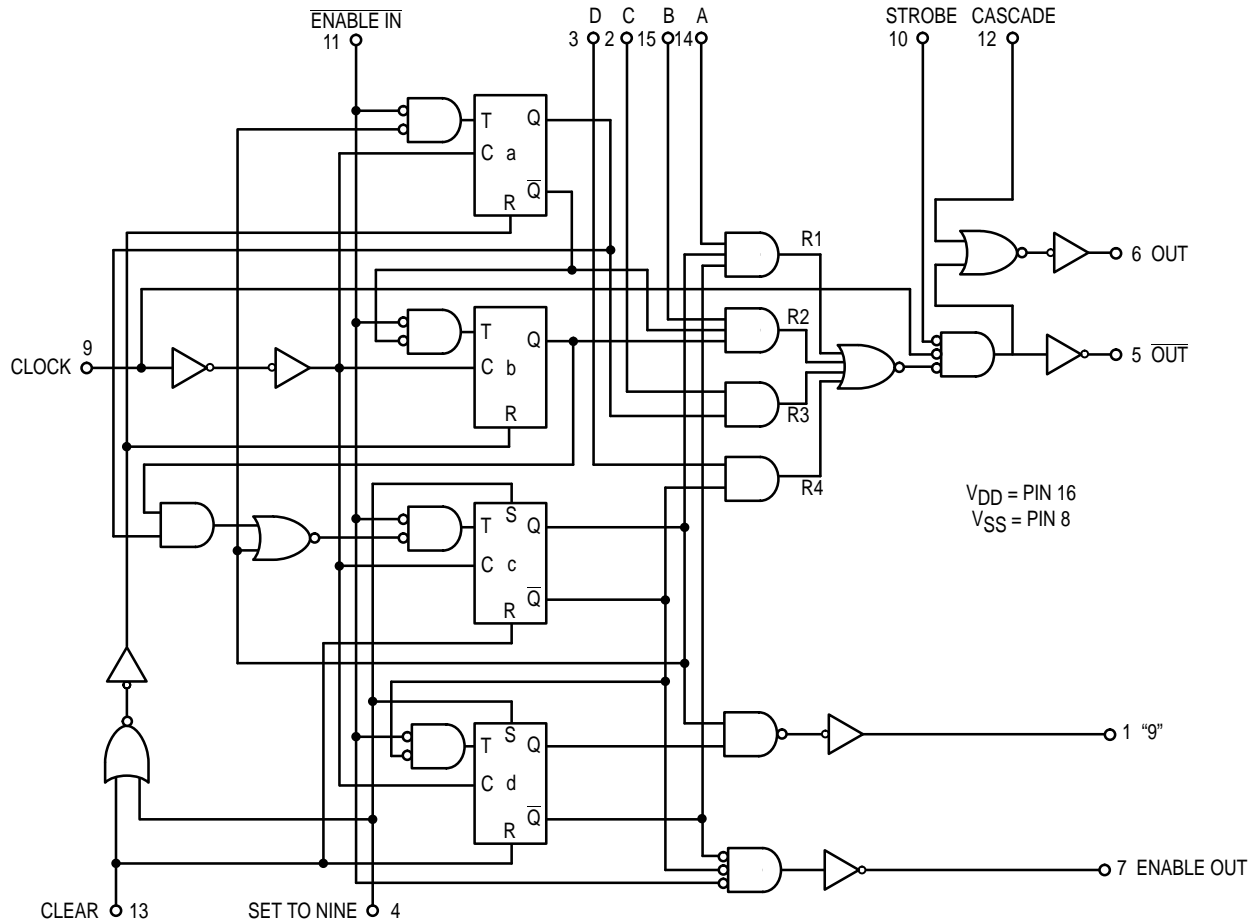

Figure 3. Power Dissipation Test Circuit and Waveform

LOGIC DIAGRAM



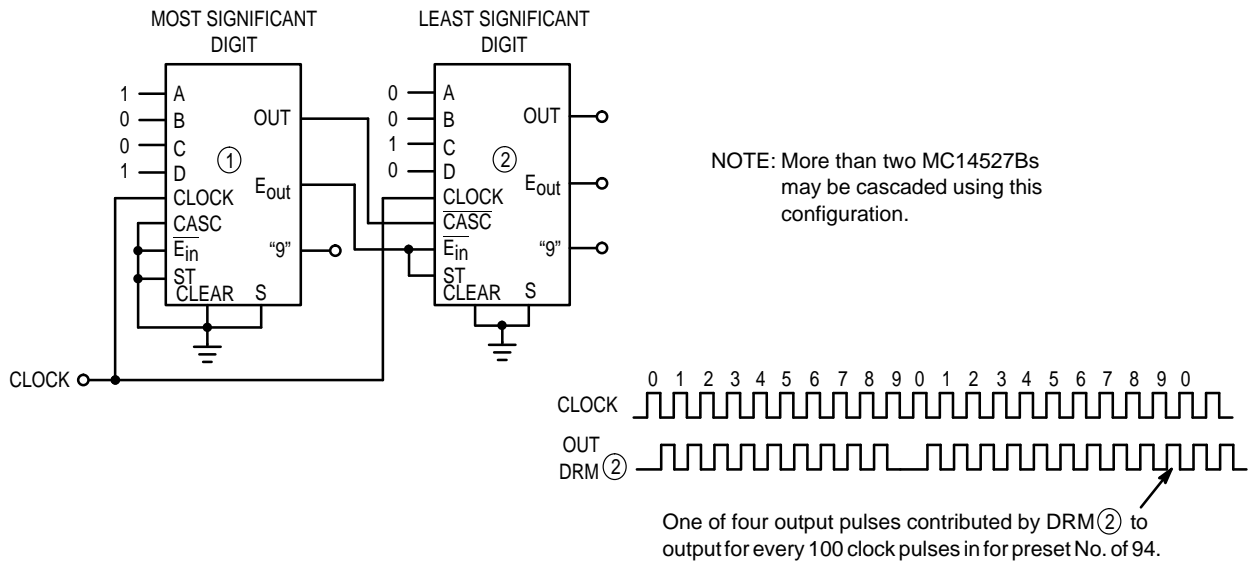
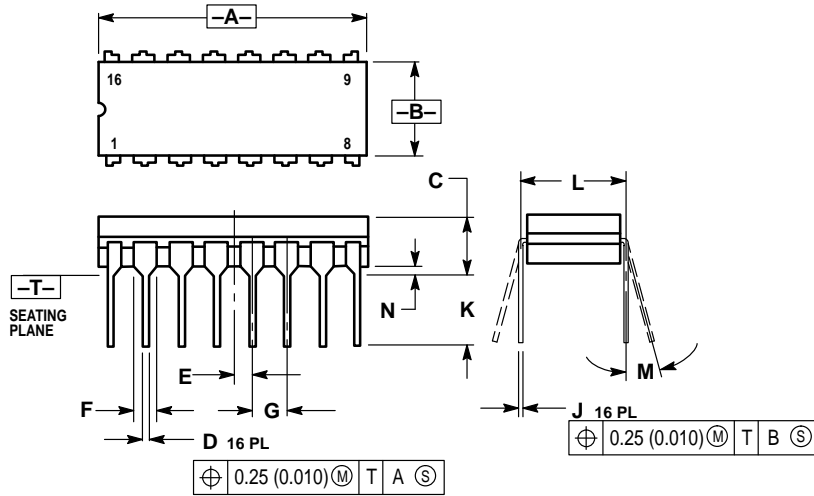

Figure 4. Two MC14527Bs in Cascade with Preset No. of 94

OUTLINE DIMENSIONS

L SUFFIX CERAMIC DIP PACKAGE CASE 620-10 ISSUE V



NOTES:

1. DIMENSIONING AND TOLERANCING PER ANSI Y14.5M, 1982.
2. CONTROLLING DIMENSION: INCH.
3. DIMENSION L TO CENTER OF LEAD WHEN FORMED PARALLEL.
4. DIMENSION F MAY NARROW TO 0.76 (0.030) WHERE THE LEAD ENTERS THE CERAMIC BODY.

| DIM | INCHES | | MILLIMETERS | |
|-----|-----------|-------|-------------|-------|
| | MIN | MAX | MIN | MAX |
| A | 0.750 | 0.785 | 19.05 | 19.93 |
| B | 0.240 | 0.295 | 6.10 | 7.49 |
| C | — | 0.200 | — | 5.08 |
| D | 0.015 | 0.020 | 0.39 | 0.50 |
| E | 0.050 BSC | | 1.27 BSC | |
| F | 0.055 | 0.065 | 1.40 | 1.65 |
| G | 0.100 BSC | | 2.54 BSC | |
| H | 0.008 | 0.015 | 0.21 | 0.38 |
| K | 0.125 | 0.170 | 3.18 | 4.31 |
| L | 0.300 BSC | | 7.62 BSC | |
| M | 0° | 15° | 0° | 15° |
| N | 0.020 | 0.040 | 0.51 | 1.01 |

P SUFFIX PLASTIC DIP PACKAGE CASE 648-08 ISSUE R

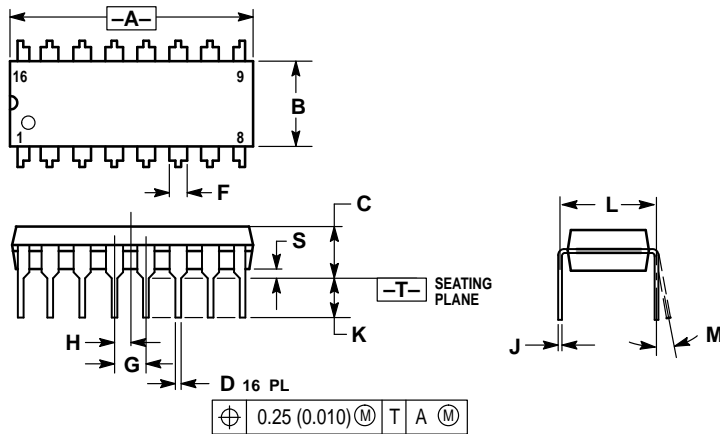

NOTES:

1. DIMENSIONING AND TOLERANCING PER ANSI Y14.5M, 1982.
2. CONTROLLING DIMENSION: INCH.
3. DIMENSION L TO CENTER OF LEADS WHEN FORMED PARALLEL.
4. DIMENSION B DOES NOT INCLUDE MOLD FLASH.
5. ROUNDED CORNERS OPTIONAL.

| DIM | INCHES | | MILLIMETERS | |
|-----|-----------|-------|-------------|-------|
| | MIN | MAX | MIN | MAX |
| A | 0.740 | 0.770 | 18.80 | 19.55 |
| B | 0.250 | 0.270 | 6.35 | 6.85 |
| C | 0.145 | 0.175 | 3.69 | 4.44 |
| D | 0.015 | 0.021 | 0.39 | 0.53 |
| F | 0.040 | 0.70 | 1.02 | 1.77 |
| G | 0.100 BSC | | 2.54 BSC | |
| H | 0.050 BSC | | 1.27 BSC | |
| J | 0.008 | 0.015 | 0.21 | 0.38 |
| K | 0.110 | 0.130 | 2.80 | 3.30 |
| L | 0.295 | 0.305 | 7.50 | 7.74 |
| M | 0° | 10° | 0° | 10° |
| S | 0.020 | 0.040 | 0.51 | 1.01 |

OUTLINE DIMENSIONS

DW SUFFIX PLASTIC SOIC PACKAGE CASE 751G-02 ISSUE A

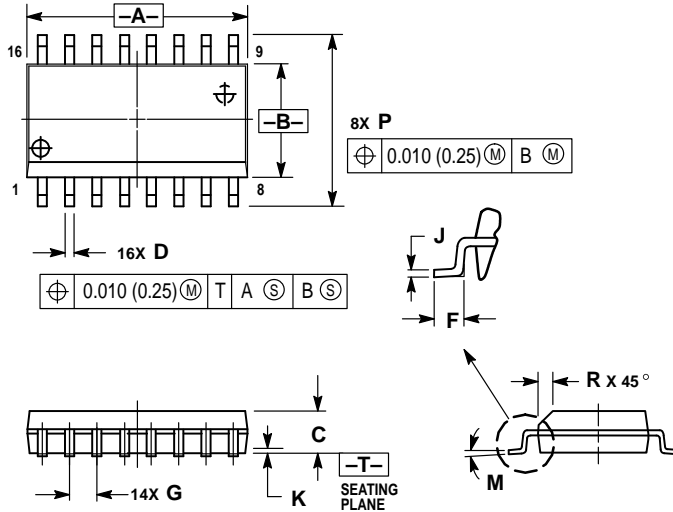

NOTES:

1. DIMENSIONING AND TOLERANCING PER ANSI Y14.5M, 1982.
2. CONTROLLING DIMENSION: MILLIMETER.
3. DIMENSIONS A AND B DO NOT INCLUDE MOLD PROTRUSION.
4. MAXIMUM MOLD PROTRUSION 0.15 (0.006) PER SIDE.
5. DIMENSION D DOES NOT INCLUDE DAMBAR PROTRUSION. ALLOWABLE DAMBAR PROTRUSION SHALL BE 0.13 (0.005) TOTAL IN EXCESS OF D DIMENSION AT MAXIMUM MATERIAL CONDITION.

| DIM | MILLIMETERS | | INCHES | |
|-----|-------------|-------|-----------|-------|
| | MIN | MAX | MIN | MAX |
| A | 10.15 | 10.45 | 0.400 | 0.411 |
| B | 7.40 | 7.60 | 0.292 | 0.299 |
| C | 2.35 | 2.65 | 0.093 | 0.104 |
| D | 0.35 | 0.49 | 0.014 | 0.019 |
| F | 0.50 | 0.90 | 0.020 | 0.035 |
| G | 1.27 BSC | | 0.050 BSC | |
| J | 0.25 | 0.32 | 0.010 | 0.012 |
| K | 0.10 | 0.25 | 0.004 | 0.009 |
| M | 0° | 7° | 0° | 7° |
| P | 10.05 | 10.55 | 0.395 | 0.415 |
| R | 0.25 | 0.75 | 0.010 | 0.029 |

Motorola reserves the right to make changes without further notice to any products herein. Motorola makes no warranty, representation or guarantee regarding the suitability of its products for any particular purpose, nor does Motorola assume any liability arising out of the application or use of any product or circuit, and specifically disclaims any and all liability, including without limitation consequential or incidental damages. "Typical" parameters which may be provided in Motorola data sheets and/or specifications can and do vary in different applications and actual performance may vary over time. All operating parameters, including "Typicals" must be validated for each customer application by customer's technical experts. Motorola does not convey any license under its patent rights nor the rights of others. Motorola products are not designed, intended, or authorized for use as components in systems intended for surgical implant into the body, or other applications intended to support or sustain life, or for any other application in which the failure of the Motorola product could create a situation where personal injury or death may occur. Should Buyer purchase or use Motorola products for any such unintended or unauthorized application, Buyer shall indemnify and hold Motorola and its officers, employees, subsidiaries, affiliates, and distributors harmless against all claims, costs, damages, and expenses, and reasonable attorney fees arising out of, directly or indirectly, any claim of personal injury or death associated with such unintended or unauthorized use, even if such claim alleges that Motorola was negligent regarding the design or manufacture of the part. Motorola and  are registered trademarks of Motorola, Inc. Motorola, Inc. is an Equal Opportunity/Affirmative Action Employer.

How to reach us:

USA/EUROPE/Locations Not Listed: Motorola Literature Distribution;
P.O. Box 20912; Phoenix, Arizona 85036. 1-800-441-2447 or 602-303-5454

MFAX: RMFAX0@email.sps.mot.com - TOUCHTONE 602-244-6609
INTERNET: <http://Design-NET.com>

JAPAN: Nippon Motorola Ltd.; Tatsumi-SPD-JLDC, 6F Seibu-Butsuryu-Center,
3-14-2 Tatsumi Koto-Ku, Tokyo 135, Japan. 03-81-3521-8315

ASIA/PACIFIC: Motorola Semiconductors H.K. Ltd.; 8B Tai Ping Industrial Park,
51 Ting Kok Road, Tai Po, N.T., Hong Kong. 852-26629298