



MX27C8000

8M-BIT [1M x8] CMOS EPROM

FEATURES

- 1M x 8 organization
- Single +5V power supply
- +12.5V programming voltage
- Fast access time: 100/120/150 ns
- Totally static operation
- Completely TTL compatible
- Operating current: 60mA
- Standby current: 100uA
- Package type:
 - 32 pin plastic DIP
 - 32 pin PLCC/SOP
 - 32 pin TSOP

GENERAL DESCRIPTION

The MX27C8000 is a 5V only, 8M-bit, One Time Programmable Read Only Memory. It is organized as 1M words by 8 bits per word, operates from a single +5 volt supply, has a static standby mode, and features fast single address location programming. All programming signals are TTL levels, requiring a single pulse. For programming outside from the system, existing EPROM

programmers may be used. The MX27C8000 supports a intelligent fast programming algorithm which can result in programming time of less than two minutes.

This EPROM is packaged in industry standard 32 pin dual-in-line packages, 32 lead PLCC, 32 lead TSOP and 32 lead SOP packages.

PIN CONFIGURATIONS

32 PDIP/SOP

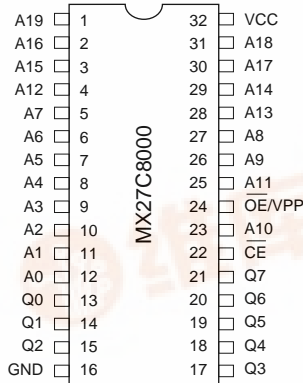

32 PLCC

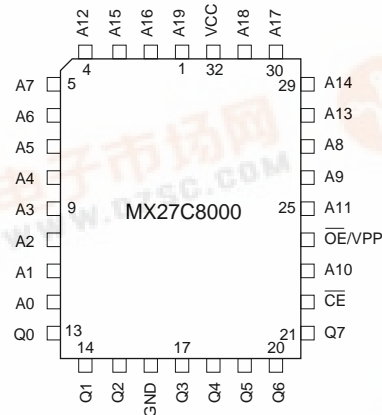

32 TSOP



BLOCK DIAGRAM

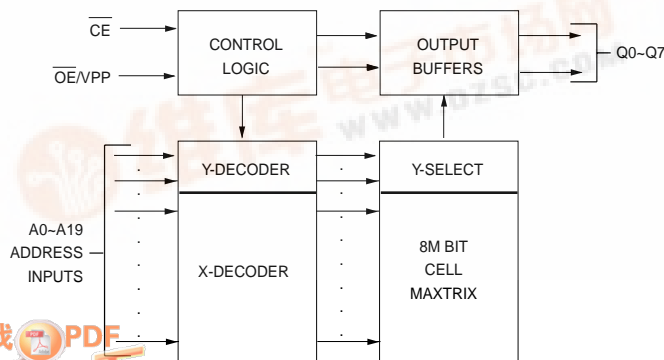

PIN DESCRIPTION

SYMBOL	PIN NAME
A0~A19	Address Input
Q0~Q7	Data Input/Output
\overline{CE}	Chip Enable Input
$\overline{OE/VPP}$	Output Enable Input/Program Supply Voltage
VCC	Power Supply Pin (+5V)
GND	Ground Pin





FUNCTIONAL DESCRIPTION

THE PROGRAMMING OF THE MX27C8000

When the MX27C8000 is delivered, or it is erased, the chip has all 8M bits in the "ONE" or HIGH state. "ZEROS" are loaded into the MX27C8000 through the procedure of programming.

For programming, the data to be programmed is applied with 8 bits in parallel to the data pins.

Vcc must be applied simultaneously or before Vpp, and removed simultaneously or after Vpp. When programming an MXIC EPROM, a 0.1uF capacitor is required across Vpp and ground to suppress spurious voltage transients which may damage the device.

FAST PROGRAMMING

The device is set up in the fast programming mode when the programming voltage $OE/VPP = 12.75V$ is applied, with $VCC = 6.25V$ (Algorithm is shown in Figure 1). The programming is achieved by applying a single TTL low level 50us pulse to the \overline{CE} input after addresses and data line are stable. If the data is not verified, an additional pulse is applied for a maximum of 25 pulses. This process is repeated while sequencing through each address of the device. When the programming mode is completed, the data in all address is verified at $VCC = 5V \pm 10\%$.

PROGRAM INHIBIT MODE

Programming of multiple MX27C8000s in parallel with different data is also easily accomplished by using the Program Inhibit Mode. Except for \overline{CE} and OE , all like inputs of the parallel MX27C8000 may be common. A TTL low-level program pulse applied to an MX27C8000 \overline{CE} input with $OE/VPP = 12.5 \pm 0.5V$ will program that MX27C8000. A high-level \overline{CE} input inhibits the other MX27C8000s from being programmed.

PROGRAM VERIFY MODE

Verification should be performed on the programmed bits to determine that they were correctly programmed. The verification should be performed with OE/VPP and \overline{CE} , at VIL , data should be verified tDV after the falling edge of \overline{CE} .

AUTO IDENTIFY MODE

The auto identify mode allows the reading out of a binary code from an EPROM that will identify its manufacturer and device type. This mode is intended for use by programming equipment for the purpose of automatically matching the device to be programmed with its corresponding programming algorithm. This mode is functional in the $25^{\circ}C \pm 5^{\circ}C$ ambient temperature range that is required when programming the MX27C8000.

To activate this mode, the programming equipment must force $12.0 \pm 0.5V$ on address line A9 of the device. Two identifier bytes may then be sequenced from the device outputs by toggling address line A0 from VIL to VIH . All other address lines must be held at VIL during auto identify mode.

Byte 0 ($A0 = VIL$) represents the manufacturer code, and byte 1 ($A0 = VIH$), the device identifier code. For the MX27C8000, these two identifier bytes are given in the Mode Select Table. All identifiers for manufacturer and device codes will possess odd parity, with the MSB (Q7) defined as the parity bit.

READ MODE

The MX27C8000 has two control functions, both of which must be logically satisfied in order to obtain data at the outputs. Chip Enable (\overline{CE}) is the power control and should be used for device selection. Output Enable (OE) is the output control and should be used to gate data to the output pins, independent of device selection. Assuming that addresses are stable, address access time ($tACC$) is equal to the delay from \overline{CE} to output (tCE). Data is available at the outputs tOE after the falling edge of OE 's, assuming that \overline{CE} has been LOW and addresses have been stable for at least $tACC - tOE$.

STANDBY MODE

The MX27C8000 has a CMOS standby mode which reduces the maximum VCC current to 100 uA. It is placed in CMOS standby when \overline{CE} is at $VCC \pm 0.3V$. The MX27C8000 also has a TTL-standby mode which reduces the maximum VCC current to 1.5 mA. It is placed in TTL-standby when \overline{CE} is at VIH . When in standby mode, the outputs are in a high-impedance state, independent of the OE input.



TWO-LINE OUTPUT CONTROL FUNCTION

To accommodate multiple memory connections, a two-line control function is provided to allow for:

1. Low memory power dissipation,
2. Assurance that output bus contention will not occur.

It is recommended that \overline{CE} be decoded and used as the primary device-selecting function, while OE be made a common connection to all devices in the array and connected to the READ line from the system control bus. This assures that all deselected memory devices are in their low-power standby mode and that the output pins are only active when data is desired from a particular memory device.

SYSTEM CONSIDERATIONS

During the switch between active and standby conditions, transient current peaks are produced on the rising and falling edges of Chip Enable. The magnitude of these transient current peaks is dependent on the output capacitance loading of the device. At a minimum, a 0.1 uF ceramic capacitor (high frequency, low inherent inductance) should be used on each device between VCC and GND to minimize transient effects. In addition, to overcome the voltage drop caused by the inductive effects of the printed circuit board traces on EPROM arrays, a 4.7 uF bulk electrolytic capacitor should be used between VCC and GND for each eight devices. The location of the capacitor should be close to where the power supply is connected to the array.

MODE SELECT TABLE

MODE	\overline{CE}	\overline{OE}/VPP	PINS		OUTPUTS
			A0	A9	
Read	VIL	VIL	X	X	DOUT
Output Disable	VIL	VIH	X	X	High Z
Standby (TTL)	VIH	X	X	X	High Z
Standby (CMOS)	VCC±0.3V	X	X	X	High Z
Program	VIL	VPP	X	X	DIN
Program Verify	VIL	VIL	X	X	DOUT
Program Inhibit	VIH	VPP	X	X	High Z
Manufacturer Code(3)	VIL	VIL	VIL	VH	C2H
Device Code(3)	VIL	VIL	VIH	VH	80H

- NOTES:**
1. VH = 12.0 V ± 0.5 V
 2. X = Either VIH or VIL

3. A1 - A8 = A10 - A19 = VIL(For auto select)
4. See DC Programming Characteristics for VPP voltage during programming.

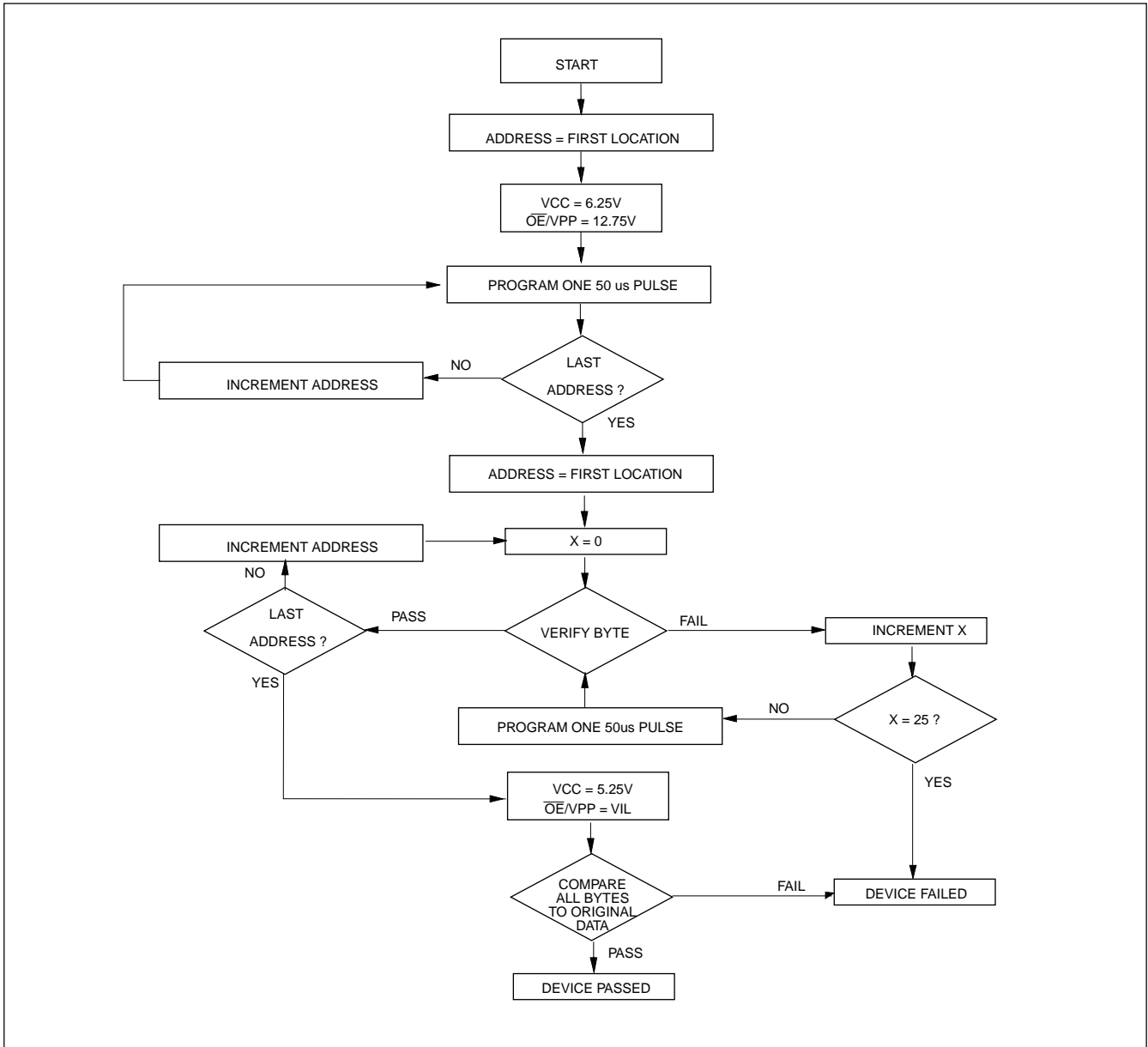
Figure 1. FAST PROGRAMMING FLOW CHART

SWITCHING TEST CIRCUITS

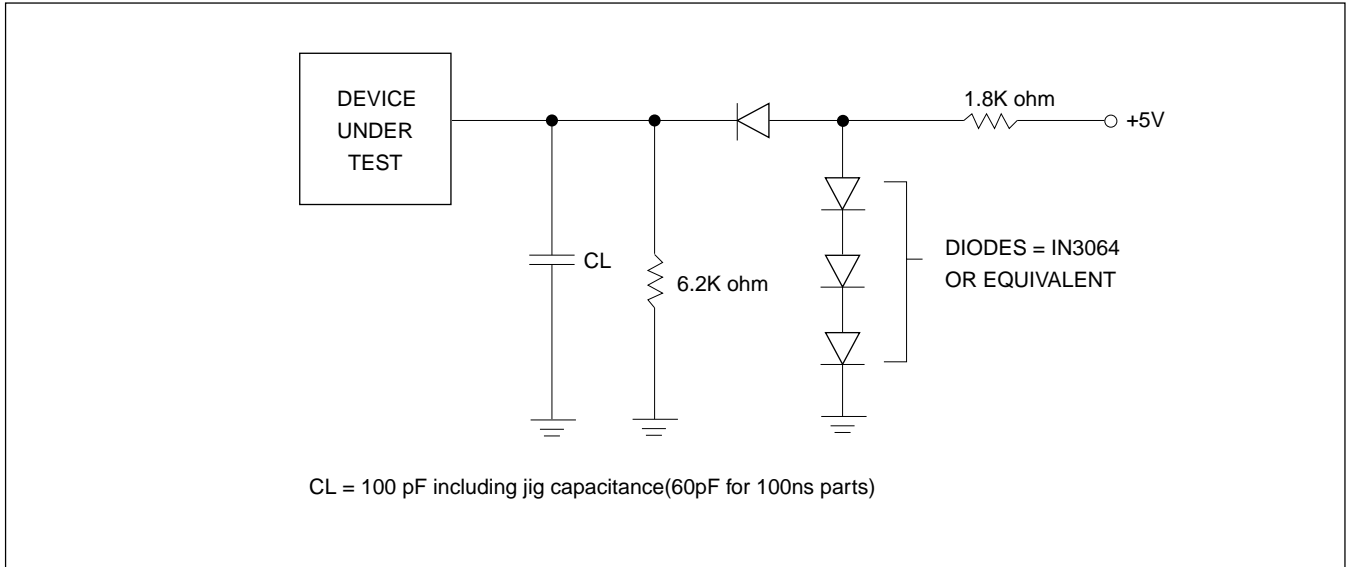

SWITCHING TEST WAVEFORMS

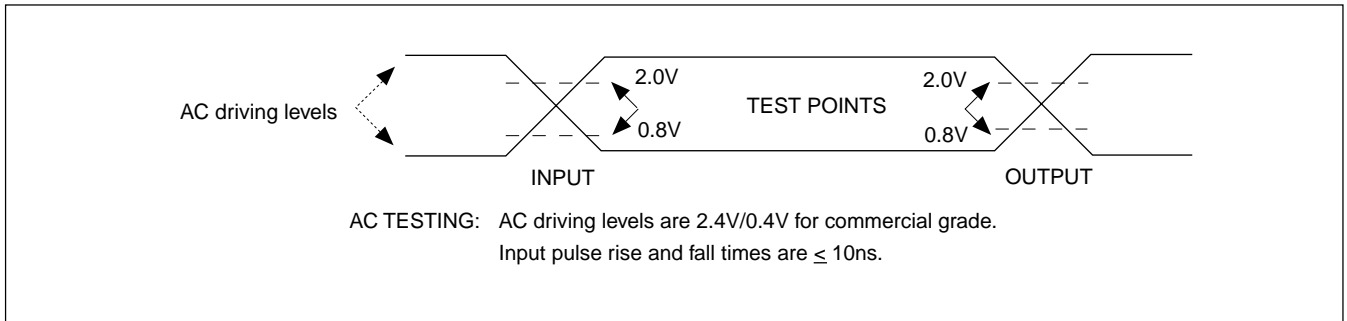



MX27C8000

ABSOLUTE MAXIMUM RATINGS

RATING	VALUE
Ambient Operating Temperature	0°C to 70°C
Storage Temperature	-65°C to 125°C
Applied Input Voltage	-0.5V to 7.0V
Applied Output Voltage	-0.5V to VCC + 0.5V
VCC to Ground Potential	-0.5V to 7.0V
V9 & VPP	-0.5V to 13.5V

NOTICE:

Stresses greater than those listed under ABSOLUTE MAXIMUM RATINGS may cause permanent damage to the device. This is a stress rating only and functional operation of the device at these or any other conditions above those indicated in the operational sections of this specification is not implied. Exposure to absolute maximum rating conditions for extended period may affect reliability.

NOTICE:

Specifications contained within the following tables are subject to change.

DC/AC Operating Condition for Read Operation

		MX27C8000		
		-10	-12	-15
Operating Temperature	Commercial	0°C to 55°C	0°C to 70°C	0°C to 70°C
Vcc Power Supply		5V ± 10%	5V ± 10%	5V ± 10%

DC CHARACTERISTICS

SYMBOL	PARAMETER	MIN.	MAX.	UNIT	CONDITIONS
VOH	Output High Voltage	2.4		V	IOH = -0.4mA
VOL	Output Low Voltage		0.4	V	IOL = 2.1mA
VIH	Input High Voltage	2.0	VCC + 0.5	V	
VIL	Input Low Voltage	-0.3	0.8	V	
ILI	Input Leakage Current	-10	10	uA	VIN = 0 to 5.5V
ILO	Output Leakage Current	-10	10	uA	VOUT = 0 to 5.5V
ICC3	VCC Power-Down Current		100	uA	$\overline{CE} = VCC \pm 0.3V$
ICC2	VCC Standby Current		1.5	mA	$\overline{CE} = VIH$
ICC1	VCC Active Current		60	mA	$\overline{CE} = VIL, f=5MHz, Iout = 0mA$
IPP	VPP Supply Current Read		10	uA	$\overline{CE} = \overline{OE} = VIL, VPP = 5.5V$

CAPACITANCE TA = 25°C, f = 1.0 MHz (Sampled only)

SYMBOL	PARAMETER	TYP.	MAX.	UNIT	CONDITIONS
CIN	Input Capacitance	8	12	pF	VIN = 0V
COUT	Output Capacitance	8	12	pF	VOUT = 0V
CVPP	VPP Capacitance	18	25	pF	VPP = 0V



MX27C8000

AC CHARACTERISTICS

SYMBOL	PARAMETER	27C8000-10		27C8000-12		27C8000-15		UNIT	CONDITIONS
		MIN.	MAX.	MIN.	MAX.	MIN.	MAX.		
tACC	Address to Output Delay		100	120		150	ns	$\overline{CE} = \overline{OE} = VIL$	
tCE	Chip Enable to Output Delay		100	120		150	ns	$\overline{OE} = VIL$	
tOE	Output Enable to Output Delay		40	50		65	ns	$\overline{CE} = VIL$	
tDF	\overline{OE} High to Output Float, or \overline{CE} High to Output Float	0	30	0	35	0	50	ns	
tOH	Output Hold from Address, \overline{CE} or \overline{OE} which ever occurred first	0		0		0		ns	

DC PROGRAMMING CHARACTERISTICS TA = 25°C ± 5°C

SYMBOL	PARAMETER	MIN.	MAX.	UNIT	CONDITIONS
VOH	Output High Voltage	2.4		V	IOH = -0.40mA
VOL	Output Low Voltage		0.4	V	IOL = 2.1mA
VIH	Input High Voltage	2.0	VCC + 0.5	V	
VIL	Input Low Voltage	-0.3	0.8	V	
ILI	Input Leakage Current	-10	10	uA	VIN = 0 to 5.5V
VH	A9 Auto Select Voltage	11.5	12.5	V	
ICC3	VCC Supply Current (Program & Verify)		50	mA	
IPP2	VPP Supply Current(Program)		30	mA	$\overline{CE} = VIL$
VCC1	Fast Programming Supply Voltage	6.00	6.50	V	
VPP1	Fast Programming Voltage	12.5	13.0	V	

AC PROGRAMMING CHARACTERISTICS TA = 25°C ± 5°C

SYMBOL	PARAMETER	MIN.	TYP.	MAX.	UNIT
tAS	Address Setup Time	2.0			us
tDS	Data Setup Time	2.0			us
tAH	Address Hold Time	0			us
tDH	Data Hold Time	2.0			us
tDFP	Chip Enable to Output Float Delay	0		130	ns
tVPS	VPP Setup Time	2.0			us
tPW	\overline{CE} Program Pulse Width		50		us
tVCS	VCC Setup Time	2.0			us
tDV	Data Valid from \overline{CE}			150	ns
tOEH	\overline{OE} /VPP Hold Time	2.0			us
tVR	\overline{OE} /VPP Recovery Time	2.0			us

WAVEFORMS READ CYCLE

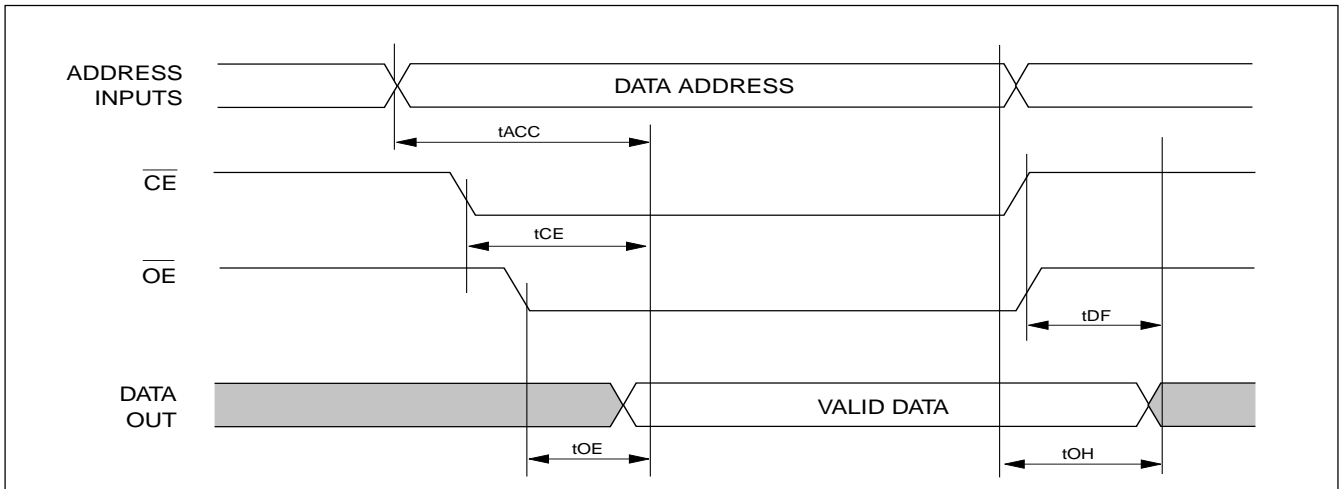

FAST PROGRAMMING ALGORITHM WAVEFORMS

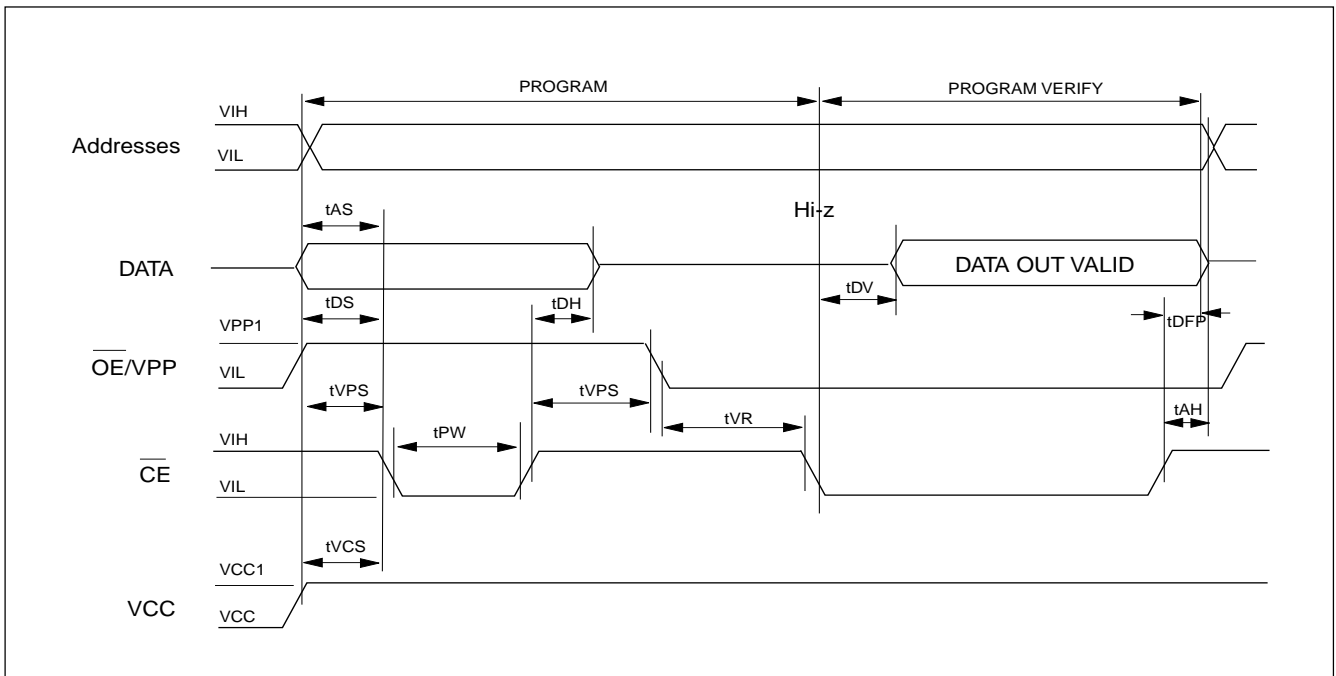



MX27C8000

ORDERING INFORMATION

PLASTIC PACKAGE

PART NO.	ACCESS TIME(ns)	OPERATING CURRENT MAX.(mA)	STANDBY CURRENT MAX.(uA)	PACKAGE
MX27C8000PC-10	100	60	100	32 Pin DIP
MX27C8000QC-10	100	60	100	32 Pin PLCC
MX27C8000MC-10	100	60	100	32 Pin SOP
MX27C8000TC-10	100	60	100	32 Pin TSOP
MX27C8000PC-12	120	60	100	32 Pin DIP
MX27C8000QC-12	120	60	100	32 Pin PLCC
MX27C8000MC-12	120	60	100	32 Pin SOP
MX27C8000TC-12	120	60	100	32 Pin TSOP
MX27C8000PC-15	150	60	100	32 Pin DIP
MX27C8000QC-15	150	60	100	32 Pin PLCC
MX27C8000MC-15	150	60	100	32 Pin SOP
MX27C8000TC-15	150	60	100	32 Pin TSOP

PACKAGE INFORMATION

32-PIN PLASTIC DIP(600 mil)

UNIT SYMBOL	INCH(BASE)	MM(REF.)
A	0.155±0.008	3.937±0.203
A1	0.025±0.005	0.635±0.127
B	0.018 (REF.)	0.457 (REF.)
B1	0.050 (REF.)	1.270 (REF.)
C	0.010 (REF.)	0.254 (REF.)
D	1.65±0.005	41.91±0.127
E	0.600±0.005	15.240±0.127
E1	0.550±0.005	13.970±0.127
e1	0.100(REF.)	2.540 (REF.)
eA	0.650±0.030	16.510±0.762
L	0.13	3.30
Q1	0.0725±0.005	1.8415±0.127
S	0.075±0.005	1.905±0.127

Mxic 旺宏電子股份有限公司 Macromix International Co., Ltd.		DWG. NO. 6110-0202.2	
TITLE PACKAGE OUTLINE FOR PDIP 32L (600 MIL)		TOLERANCE X ± XX ±.01 XXX±.002	
DRAWN	APPROVED	DATE	UNIT
C.L.Chiang	Leo Lee	05-02-01	
		REVISION	4

32-PIN PLASTIC SOP(450 mil)

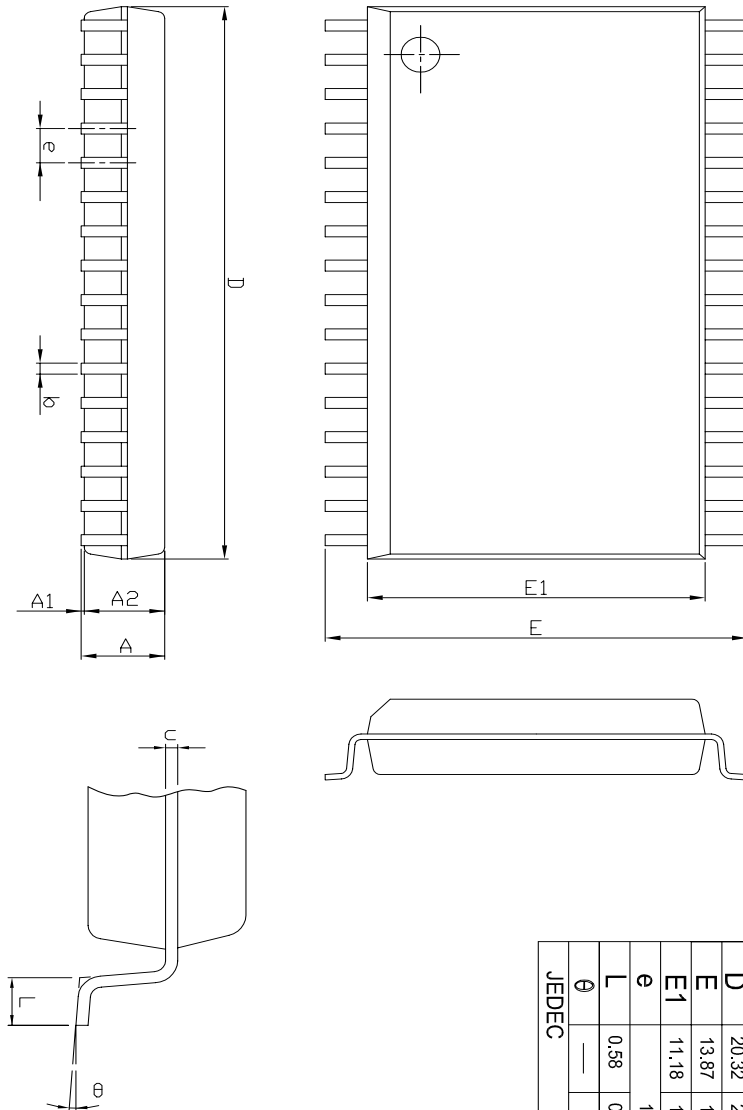

Symbol	Dimension in mm (Base)			Dimension in inch (Ref.)		
	Min	Nom	Max	Min	Nom	Max
A	—	—	3.00	—	—	0.118
A1	0.10	—	—	0.004	—	—
A2	2.57	2.69	2.82	0.101	0.106	0.111
b	0.41 REF			0.016 REF		
c	0.20 REF			0.008 REF		
D	20.32	20.45	20.57	0.800	0.805	0.810
E	13.87	14.12	14.38	0.546	0.556	0.566
E1	11.18	11.30	11.43	0.440	0.445	0.450
e	1.27 REF			0.050 REF		
L	0.58	0.79	0.99	0.023	0.031	0.039
phi	—	5°	—	—	5°	—

JEDEC

Mxic 旺宏電子股份有限公司		DWG. NO.	
Macronix International Co., Ltd.		6110-0206	
TITLE PACKAGE OUTLINE FOR SOP 32L (450 MIL)			
DRAWN C.L.Chiang		REVISION 2	
APPROVED Dennis Chang		DATE 05-03-01	
UNIT INCH		ROUGHNESS	
TOLERANCE		X ±.01	
XX ±.01		ANGLE	
.XXX±.002		ROUGHNESS	

32-PIN PLASTIC LEADED CHIP CARRIER (PLCC)

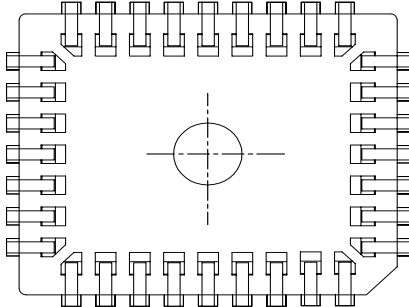
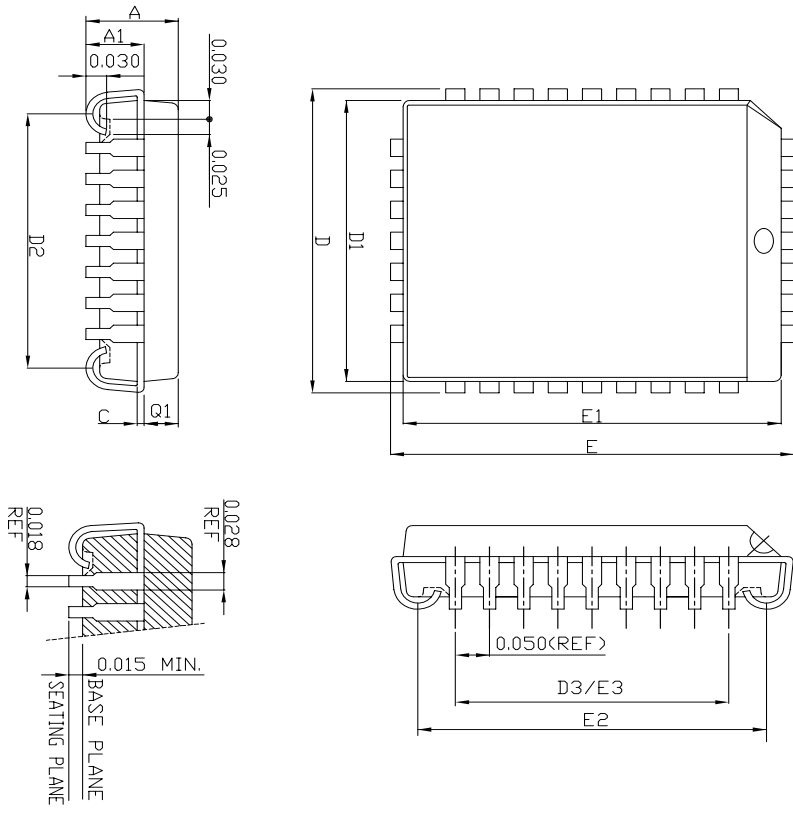

Symbol	Dimension in inch (Ref.)			Dimension in mm (Base)		
	Min	Nom	Max	Min	Nom	Max
A			0.140			3.56
A1	0.090	0.085	0.090	2.03	2.16	2.29
Q1	0.048	0.050	0.052	1.22	1.27	1.32
C	0.010(REF)			0.25(REF)		
D	0.485	0.490	0.495	12.32	12.45	12.57
D1	0.450	0.453	0.456	11.43	11.51	11.58
D2	0.400	0.410	0.420	10.16	10.41	10.67
D3	0.300(REF)			7.62(REF)		
E	0.585	0.590	0.595	14.86	14.99	15.11
E1	0.550	0.553	0.556	13.97	14.05	14.12
E2	0.500	0.510	0.520	12.70	12.95	13.21
E3	0.400(REF)			10.16(REF)		

REFERENCE DOCUMENT : JEDEC SPEC - MS-016a

旺宏電子股份有限公司 Macronix International Co., Ltd.		DWG. NO. 6110-0209.1	
TITLE PACKAGE OUTLINE FOR PLCC 32L			
TOLERANCE X #. XX ±.01 .XXX±.002		ANGLE ±2°	
DRAWN C.L.Chiang	APPROVED Dennis Chang	DATE 05-03-01	UNIT inch
REVISION 2			

32-PIN PLASTIC TSOP

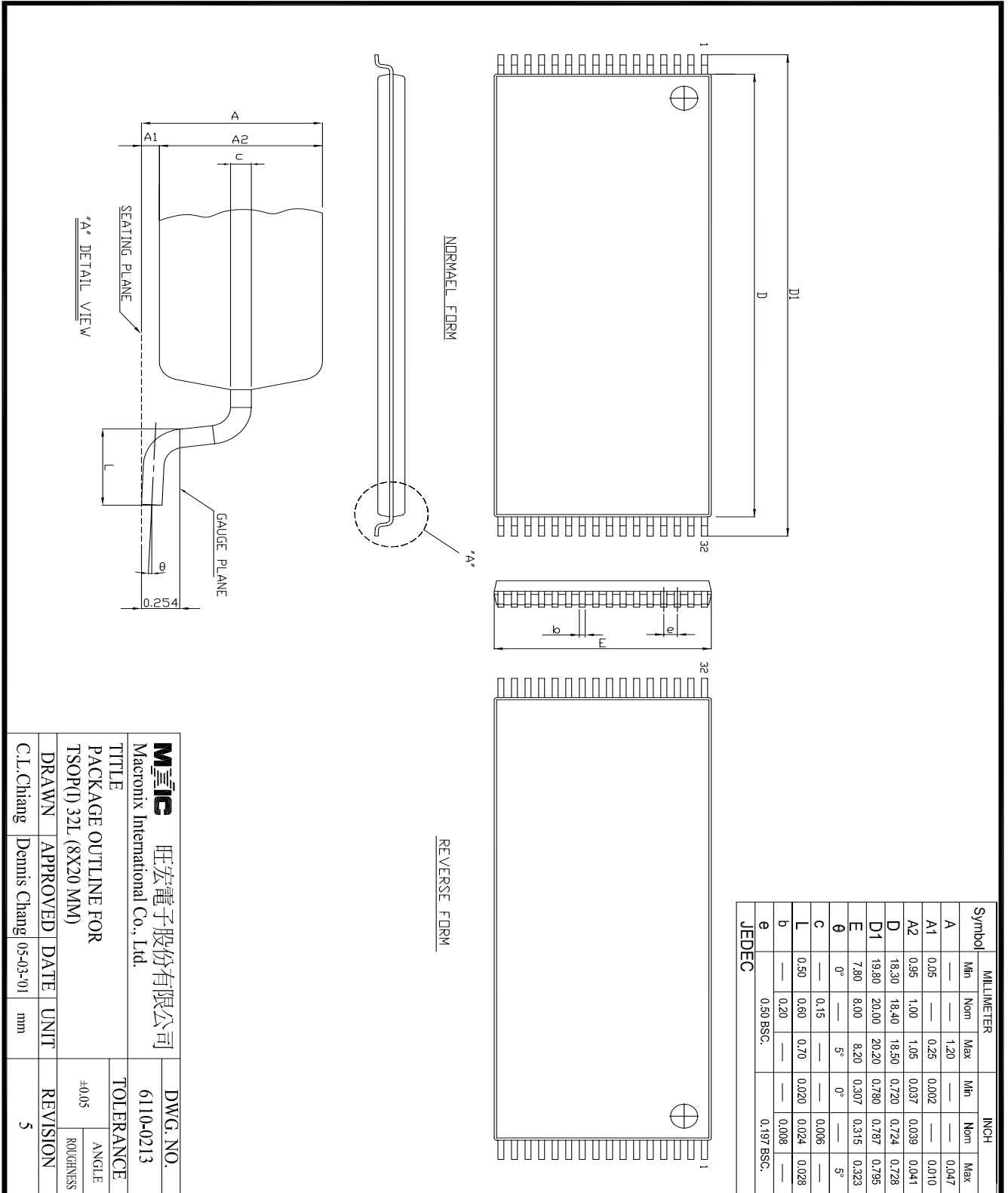

Mxic 旺宏電子股份有限公司 Macromix International Co., Ltd.		DWG. NO. 6110-0213	
TITLE PACKAGE OUTLINE FOR TSOP(D) 32L (8X20 MM)		TOLERANCE ±0.05	
DRAWN	APPROVED	DATE	UNIT
C.L.Chang	Dennis Chang	05-03-01	mm
REVISION		5	



REVISION HISTORY

Revision No.	Description	Page	Date
2.0	1) Eliminate Interactive Programming Mode. 2) Programming pulse change from 100us to 50us.		5/30/1997
3.0	1) Partial specification change for 100ns speed grade 1-1) SWITCHING TEST Condition CL = 100pF ---> CL = 60pF 1-2) Operating Temperature 0°C to 70°C ----> 0°C to 55°C 1-3) Vcc, 5V ± 10% ----> 5V ± 5% 2) IPP1 100uA ----> 10uA.		7/18/1997
3.1	1) Partial specification change for 100ns speed grade, VCC: 5V ± 5% ----> 5V ± 10%		12/19/1997
3.2	Added 32pin TSOP package type	P1,12	OCT/20/1999
3.3	Correcting Ordering Information	P9	OCT/21/1999
3.4	Cancel ceramic DIP package type	P1,2,9,10	MAR/02/2000
3.5	Cancel "Ultraviolet Erasable" wording in General Description To modify Package Information	P1 P10~13	AUG/20/2001



MX27C8000

MACRONIX INTERNATIONAL Co., LTD.

HEADQUARTERS:

TEL:+886-3-578-6688

FAX:+886-3-563-2888

EUROPE OFFICE:

TEL:+32-2-456-8020

FAX:+32-2-456-8021

JAPAN OFFICE:

TEL:+81-44-246-9100

FAX:+81-44-246-9105

SINGAPORE OFFICE:

TEL:+65-348-8385

FAX:+65-348-8096

TAIPEI OFFICE:

TEL:+886-2-2509-3300

FAX:+886-2-2509-2200

MACRONIX AMERICA, INC.

TEL:+1-408-453-8088

FAX:+1-408-453-8488

CHICAGO OFFICE:

TEL:+1-847-963-1900

FAX:+1-847-963-1909

[http : //www.macronix.com](http://www.macronix.com)
