

**TOSHIBA**

**TMP87CM38/P38/S38**

CMOS 8-Bit Microcontroller

**TMP87CM38N/F, TMP87CP38N/F, TMP87CS38N/F**

The 87CM38/P38/S38 is the high speed and high performance 8-bit single chip microcomputer. This MCU contains CPU core, ROM, RAM, input/output ports, six multi-function timer / counter, serial bus interface, on-screen display, PWM, 8-bit A/D converter and remote control signal preprocessor on a chip.

Part No.	ROM	RAM	Package	OTP MCU
TMP87CM38N/F	32 Kbytes	1 Kbytes	P-SDIP42-600-1.78 P-QFP44-1414-0.80D	TMP87PS38N/F
TMP87CP38N/F	48 Kbytes	2 Kbytes		
TMP87CS38N/F	60 Kbytes	2 Kbytes		

**Features**

- ◆ 8-bit single chip microcomputer TLCS-870 Series
- ◆ Instruction execution time : 0.5  $\mu$ s (at 8 MHz)
- ◆ 412 basic instructions
  - Multiplication and Division (8bits  $\times$  8bits , 16bits  $\div$  8bits)
  - Bit manipulations(Set/Clear/Complement/Move/Test/Exclusive Or)
  - 16-bit data operations
  - 1-byte jump / subroutine-call (Short relative jump / Vector call)
- ◆ 14 interrupt sources (External : 5, Internal : 9)
  - All sources have independent latches each, and nested interrupt control is available.
  - 3 edge-selectable external interrupts with noise reject
  - High-speed task switching by register bank changeover
- ◆ ROM Corrective Function
- ◆ 6 Input / Output ports (33 pins)
  - High current output : 4 pins (typ. 20 mA)
- ◆ Two 16-bit Timer / Counters
  - Timer, Event counter, Pulse width measurement, External trigger timer, Window modes

030619EBP1

● The information contained herein is subject to change without notice.

● The information contained herein is presented only as a guide for the applications of our products. No responsibility is assumed by TOSHIBA for any infringements of patents or other rights of the third parties which may result from its use. No license is granted by implication or otherwise under any patent or patent rights of TOSHIBA or others.

● TOSHIBA is continually working to improve the quality and reliability of its products. Nevertheless, semiconductor devices in general can malfunction or fail due to their inherent electrical sensitivity and vulnerability to physical stress. It is the responsibility of the buyer, when utilizing TOSHIBA products, to comply with the standards of safety in making a safe design for the entire system, and to avoid situations in which a malfunction or failure of such TOSHIBA products could cause loss of human life, bodily injury or damage to property.

In developing your designs, please ensure that TOSHIBA products are used within specified operating ranges as set forth in the most recent TOSHIBA products specifications. Also, please keep in mind the precautions and conditions set forth in the "Handling Guide for Semiconductor Devices," or "TOSHIBA Semiconductor Reliability Handbook" etc..

● The TOSHIBA products listed in this document are intended for usage in general electronics applications (computer, personal equipment, office equipment, measuring equipment, industrial robotics, domestic appliances, etc.). These TOSHIBA products are neither intended nor warranted for usage in equipment that requires extraordinarily high quality and/or reliability or a malfunction or failure of which may cause loss of human life or bodily injury ("Unintended Usage"). Unintended Usage include atomic energy control instruments, airplane or spaceship instruments, transportation instruments, traffic signal instruments, combustion control instruments, medical instruments, all types of safety devices, etc.. Unintended Usage of TOSHIBA products listed in this document shall be made at the customer's own risk.

● The products described in this document are subject to the foreign exchange and foreign trade laws.

● TOSHIBA products should not be embedded to the downstream products which are prohibited to be produced and sold, under any law and regulations.

● For a discussion of how the reliability of microcontrollers can be predicted, please refer to Section 1.3 of the chapter entitled Quality and Reliability Assurance/ Handling Precautions.



Purchase of TOSHIBA I<sup>2</sup>C components conveys a license under the Philips I<sup>2</sup>C Patent Rights to use these components in an I<sup>2</sup>C system, provided that the system conforms to the I<sup>2</sup>C Standard Specification as defined by Philips.



- ◆ Two 8-bit Timer / Counters
  - Timer, Event counter, Capture (Pulse width / duty measurement) modes
- ◆ Time Base Timer (Interrupt frequency : 1 Hz to 16 kHz)
- ◆ Watchdog Timer
  - Interrupt source / reset output (programmable)
- ◆ Serial bus Interface
  - I<sup>2</sup>C-bus, 8-bit SIO modes
- ◆ On-screen display circuit
  - Character patterns : 256 characters
  - Characters displayed : 24 columns × 12 lines
  - Composition : 14 × 18 dots
  - Size of character : 3 kinds (line by line)
  - Color of character : 8 kinds (character by character)
  - Variable display position : Horizontal 128 steps, Vertical 256 steps
  - Fringing, Smoothing function
- ◆ D/A conversion (Pulse Width Modulation) outputs
  - 14-bit resolution (1 channel)
  - 7-bit resolution (9 channels)
- ◆ 8-bit successive approximate type A/D converter with sample and hold
- ◆ Remote control signal preprocessor
- ◆ Two Power saving operating modes
  - STOP mode : Oscillation stops. Battery / Capacitor back-up. Port output hold / high-impedance.
  - IDLE mode : CPU stops, and Peripherals operate. Release by interrupts.
- ◆ Jitter Elimination
- ◆ Emulation Pod : BM87CS38N0A

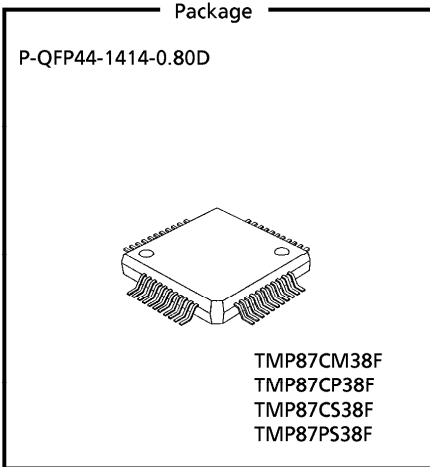

Pin Assignments

P-QFP44-1414-0.80D

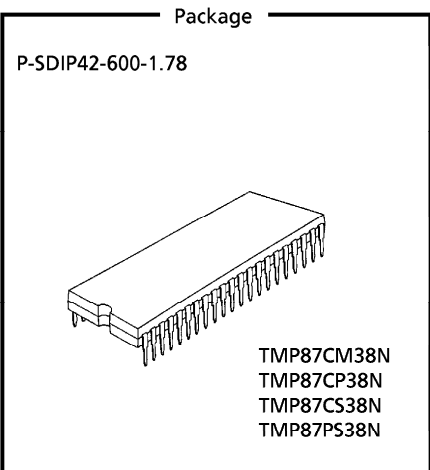
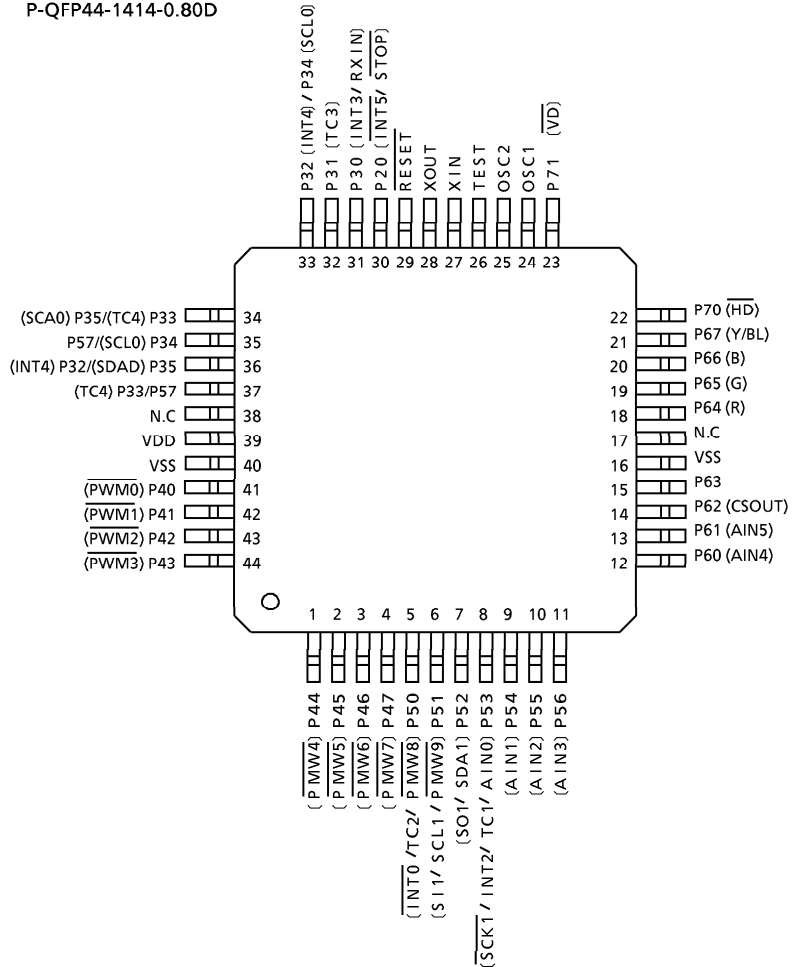

Pin Assignments

P-SDIP42-600-1.78

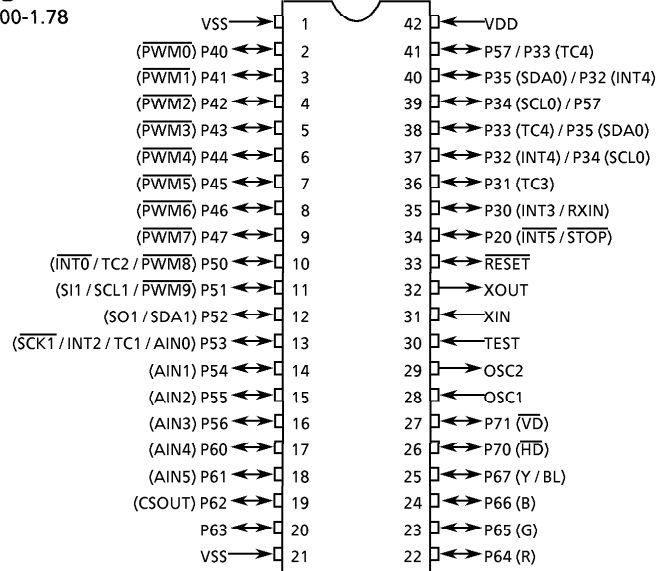

Block Diagram

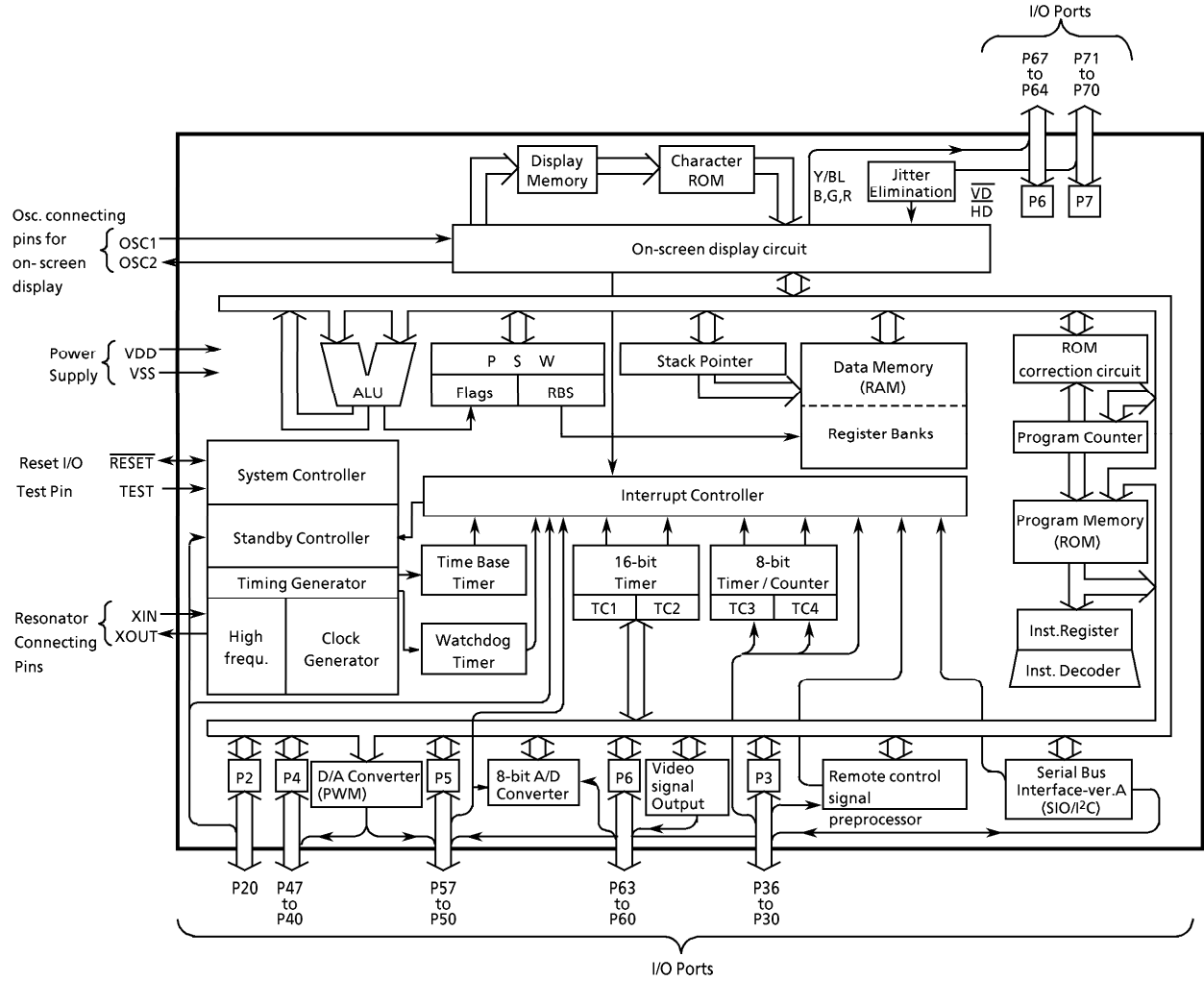

## Pin Function

Pin Name	Input / Output	Function		
P20 (INT5/STOP)	I/O (Input)	1-bit input / output port with latch. When used as an input port, the latch must be set to "1".	External interrupt input 5 or STOP mode release signal input	
P35 (SDA0)	I/O (I/O)	6-bit input/output port with latch. When used as an input port, a serial bus interface input/output, a timer/counter input, a remote control signal preprocessor input, or an external interrupt input, the latch must be set to "1".	I <sup>2</sup> Cbus serial data input/output	
P34 (SCL0)	I/O (I/O)		I <sup>2</sup> Cbus serial clock input/output	
P33 (TC4)	I/O (Input)		Timer / Counter 4 input	
P32 (INT4)			External interrupt input 4	
P31 (TC3)			Timer / Counter 3 input	
P30 (INT3/RXIN)	I/O (Input/Input)		External interrupt input 3 or remote control signal preprocessor input	
P47 (PWM7) to P41 (PWM1)	I/O (Output)	8-bit programmable input/output port (tri-state). Each bit of this port can be individually configured as an input or an output under software control. During reset, all bits are configured as inputs. When used as a PWM output, the latch must be set to "1".	7-bit D/A conversion (PWM) outputs	
P40 (PWM0)			14-bit D/A conversion (PWM) output	
P57 P56 (AIN3) to P53 (AIN0)	I/O (Input)	8-bit input/output port with latch. When used as an input port, an analog input, a PWM output, or a pulse output, the latch must be set to "1".	8-bit A/D conversion inputs	
P53 (AIN0 / TC1 / INT2 / SCK1)	I/O		A/D conversion inputs or Timer / Counter 1 inputs or interrupt input 2 or SIO serial clock input/output	
P52 (SDA1/SO1)	I/O (Input/Output)		I <sup>2</sup> Cbus serial data input/output or SIO Serial data output	
P51 (PWM9 /SCL1/SI1)			7-bit D/A conversion (PWM) outputs	
P50 (PWM8/TC2 /INT0)			I <sup>2</sup> Cbus serial data input / output or SIO Serial data input	
			Timer / Counter 2 input / External interrupt input 0	
P67 (Y/BL) P66 (B) P65 (G) P64 (R)	I/O(Output)	8-bit programmable input/output port (P67 to P64 : tri-state, P63 to P60 : High current output). Each bit of this port can be individually configured as an input or an output under software control. During reset, all bits are configured as inputs. When used as the R, G, B, Y / BL outputs of on-screen display circuit, each bit of the P6 port data selection register (bits 7 to 4 in address 0F91H) must be set to "1".	Focus signal output or Background blanking control signal output	
P63			RGB output	
P62 (CSOUT)				High current output.
P61 (AIN5)			I/O	Test video signal output
P60 (AIN4)				A/D conversion inputs
P71 (VD)				I/O (Input)
P70 (HD)			Horizontal synchronous signal input	
OSC1, OSC2	Input, Output	Resonator connecting pins for on-screen display circuitry.		
XIN, XOUT		Resonator connecting pins. For inputting external clock, XIN is used and XOUT is opened.		
RESET	I/O	Reset signal input or watchdog timer output/address-trap- reset output/system-clock-reset output.		
TEST	Input	Test pin for out-going test. Be tied to low.		
VDD, VSS	Power Supply	+ 5 V, 0 V (GND)		

Operational Description

1. CPU Core Functions

The CPU core consists of a CPU, a system clock controller, an interrupt controller, and a watchdog timer. This section provides a description of the CPU core, the program memory (ROM), the data memory (RAM), and the reset circuit.

1.1 Memory Address Map

The TLCS-870 Series is capable of addressing 64 K bytes of memory. Figure 1-1 shows the memory address maps of the 87CM38/P38/S38. In the TLCS-870 Series, the memory is organized 4 address spaces (ROM, RAM, SFR, and DBR). It uses a memory mapped I/O system, and all I/O registers are mapped in the SFR / DBR address spaces. There are 16 banks of general-purpose registers. The register banks are also assigned to the first 128 bytes of the RAM address space.

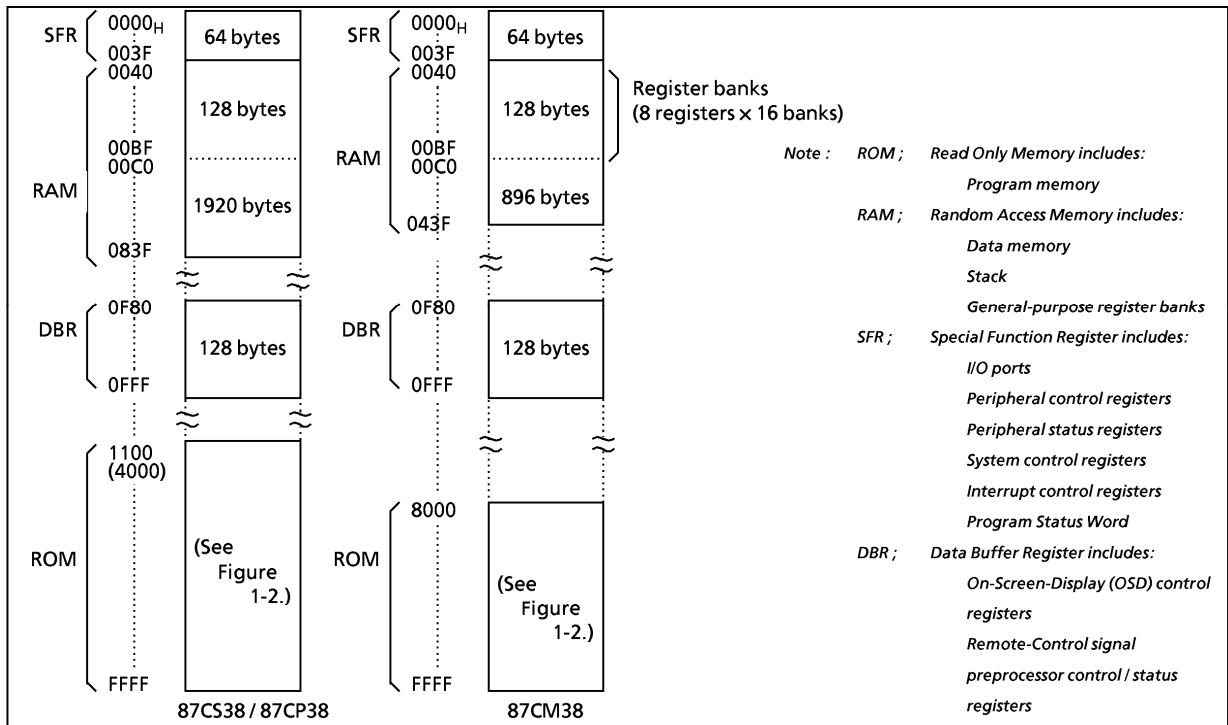

Figure 1-1. Memory address map

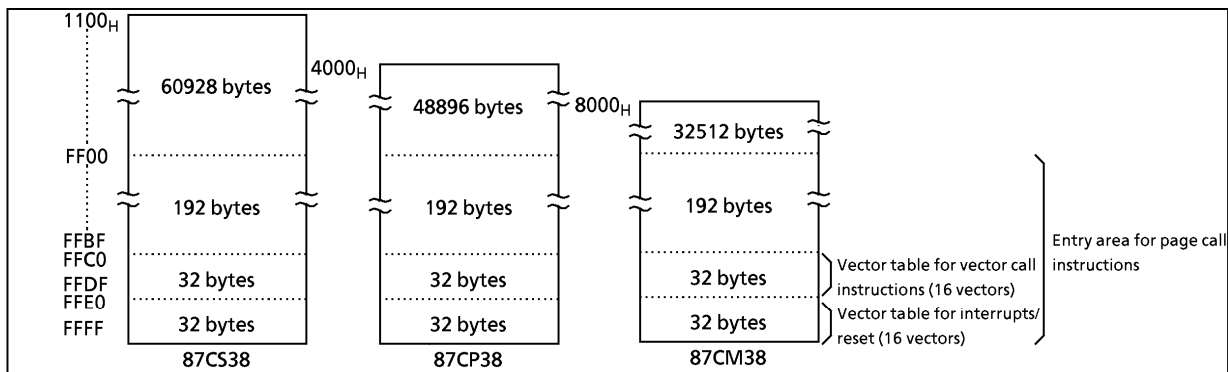

Figure 1-2. ROM address maps

## Electrical Characteristics

## Absolute maximum ratings

(V<sub>SS</sub> = 0 V)

Parameter	Symbol	Pins	Ratings	Unit
Supply Voltage	V <sub>DD</sub>		- 0.3 to 6.5	V
Input Voltage	V <sub>IN</sub>		- 0.3 to V <sub>DD</sub> + 0.3	V
Output Voltage	V <sub>OUT1</sub>		- 0.3 to V <sub>DD</sub> + 0.3	V
Output Current (Per 1 pin)	I <sub>OUT1</sub>	Ports P2, P3, P4, P5, P64 to P67, P7	3.2	mA
	I <sub>OUT2</sub>	Ports P60 to P63	30	
Output Current (Total)	ΣI <sub>OUT1</sub>	Ports P2, P3, P4, P5, P64 to P67, P7	120	mA
	ΣI <sub>OUT2</sub>	Ports P60 to P63	120	
Power Dissipation [Topr = 70°C]	PD		600	mW
Soldering Temperature (time)	T <sub>sld</sub>		260 (10 s)	°C
Storage Temperature	T <sub>stg</sub>		- 55 to 125	°C
Operating Temperature	Topr		- 30 to 70	°C

**Note1:** The absolute maximum ratings are rated values which must not be exceeded during operation, even for an instant. Any one of the ratings must not be exceeded. If any absolute maximum rating is exceeded, a device may break down or its performance may be degraded, causing it to catch fire or explode resulting in injury to the user. Thus, when designing products which include this device, ensure that no absolute maximum rating value will ever be exceeded.

## Recommended operating conditions

(V<sub>SS</sub> = 0 V, Topr = - 30 to 70°C)

Parameter	Symbol	Pins	Conditions	Min	Max	Unit
Supply Voltage	V <sub>DD</sub>		NORMAL mode	4.5	5.5	V
			IDLE mode			
			STOP mode	2.0		
Input High Voltage	V <sub>IH1</sub>	Except hysteresis input		V <sub>DD</sub> × 0.70	V <sub>DD</sub>	V
	V <sub>IH2</sub>	Hysteresis input		V <sub>DD</sub> × 0.75		
Input Low Voltage	V <sub>IL1</sub>	Except hysteresis input		0	V <sub>DD</sub> × 0.30	V
	V <sub>IL2</sub>	Hysteresis input			V <sub>DD</sub> × 0.25	
Clock Frequency	f <sub>c</sub>	XIN, XOUT		4.0	8.0	MHz
	f <sub>OSC</sub>	OSC1, OSC2	Normal frequency mode (FORS = 0, V <sub>DD</sub> = 4.5 to 5.5 V)	4.0	f <sub>OSC</sub> ≤ f <sub>c</sub> × 1.2 ≤ 8.0	
			Double frequency mode (FORS = 1, V <sub>DD</sub> = 4.5 to 5.5 V)	2.0	f <sub>OSC</sub> ≤ f <sub>c</sub> × 0.6 ≤ 4.0	

**Note1:** The recommended operating conditions for a device are operating conditions under which it can be guaranteed that the device will operate as specified. If the device is used under operating conditions other than the recommended operating conditions (supply voltage, operating temperature range, specified AC/DC values etc.), malfunction may occur. Thus, when designing products which include this device, ensure that the recommended operating conditions for the device are always adhered to.

**Note2:** Clock Frequency f<sub>c</sub>; The condition of supply voltage range is the value in NORMAL and IDLE modes.

**Note3:** When using test video signal circuit and data slicer circuit, high frequency must be 8 MHz.

## D.C. characteristics

 $(V_{SS} = 0\text{ V}, T_{opr} = -30\text{ to }70^{\circ}\text{C})$ 

Parameter	Symbol	Pins	Conditions	Min	Typ.	Max	Unit
Hysteresis Voltage	$V_{HS}$	Hysteresis inputs		–	0.9	–	V
Input Current	$I_{IN1}$	TEST	$V_{DD} = 5.5\text{ V}, V_{IN} = 5.5\text{ V} / 0\text{ V}$	–	–	$\pm 2$	$\mu\text{A}$
	$I_{IN2}$	Open drain ports	$V_{DD} = 5.5\text{ V}, V_{IN} = 5.5\text{ V} / 0\text{ V}$	–	–	$\pm 2$	
	$I_{IN3}$	Tri-state ports	$V_{DD} = 5.5\text{ V}, V_{IN} = 5.5\text{ V} / 0\text{ V}$	–	–	$\pm 2$	
	$I_{IN4}$	RESET, STOP	$V_{DD} = 5.5\text{ V}, V_{IN} = 5.5\text{ V} / 0\text{ V}$	–	–	$\pm 2$	
Input Resistance	$R_{IN2}$	RESET		100	220	450	$\text{k}\Omega$
Output Leakage Current	$I_{LO1}$	Sink open drain ports	$V_{DD} = 5.5\text{ V}, V_{OUT} = 5.5\text{ V}$	–	–	2	$\mu\text{A}$
	$I_{LO2}$	Tri-state ports	$V_{DD} = 5.5\text{ V}, V_{OUT} = 5.5\text{ V} / 0\text{ V}$	–	–	$\pm 2$	
Output High Voltage	$V_{OH2}$	Tri-state port	$V_{DD} = 4.5\text{ V}, I_{OH} = -0.7\text{ mA}$	4.1	–	–	V
Output Low Voltage	$V_{OL}$	Except XOUT, OSC2 and ports P60 to P63	$V_{DD} = 4.5\text{ V}, I_{OL} = 1.6\text{ mA}$	–	–	0.4	V
Output Low Current	$I_{OL3}$	Ports P60 to P63	$V_{DD} = 4.5\text{ V}, V_{OL} = 1.0\text{ V}$	–	20	–	mA
Supply Current in NORMAL mode			$V_{DD} = 5.5\text{ V}$ $f_c = 8\text{ MHz}$ $V_{IN} = 5.3\text{ V} / 0.2\text{ V}$	–	14	17	mA
Supply Current in IDLE mode				–	7	10	mA
Supply Current in STOP mode			$V_{DD} = 5.5\text{ V}$ $V_{IN} = 5.3\text{ V} / 0.2\text{ V}$	–	0.5	10	$\mu\text{A}$

Note 1: Typical values show those at  $T_{opr} = 25^{\circ}\text{C}$ ,  $V_{DD} = 5\text{ V}$ .

Note 2: Input Current  $I_{IN1}, I_{IN4}$ ; The current through pull-up or pull-down resistor is not included.

Note 3: Supply Current  $I_{DD}$ ; The current (Typ. 0.5 mA) through ladder resistors of ADC is included in NORMAL mode and IDEL mode.

## A/D conversion characteristics

 $(V_{SS} = 0\text{ V}, V_{DD} = 4.5\text{ V to }5.5\text{ V } T_{opr} = -30\text{ to }70^{\circ}\text{C})$ 

Parameter	Symbol	Conditions	Min	Typ.	Max	Unit
Analog Reference Voltage	$V_{AREF}$	supplied from $V_{DD}$ pin.	–	$V_{DD}$	–	V
	$V_{ASS}$	supplied from $V_{SS}$ pin.	–	0	–	
Analog Reference Voltage Range	$\Delta V_{AREF}$	$= V_{DD} - V_{SS}$	–	$V_{DD}$	–	
Analog Input Voltage	$V_{AIN}$		$V_{SS}$	–	$V_{DD}$	
Nonlinearity Error		$V_{DD} = 4.5\text{ V to }5.5\text{ V}$	–	–	$\pm 1$	LSB
zero Point Error			–	–	$\pm 2$	
Full Scale Error			–	–	$\pm 2$	
Total Error			–	–	$\pm 3$	



A.C. characteristics

( $V_{SS} = 0\text{ V}$ ,  $V_{DD} = 4.5\text{ to }5.5\text{ V}$ ,  $T_{opr} = -30\text{ to }70^\circ\text{C}$ )

Parameter	Symbol	Conditions	Min	Typ.	Max	Unit
Machine Cycle Time	t <sub>cy</sub>	In NORMAL mode	0.5	-	1.0	μs
		In IDLE mode				
High-Level Clock Pulse Width	t <sub>WCH</sub>	For external clock operation (XIN input), f <sub>c</sub> = 8MHz	62.5	-	-	ns
Low-Level Clock Pulse Width	t <sub>WCL</sub>					

Recommended oscillating condition

( $V_{SS} = 0\text{ V}$ ,  $V_{DD} = 4.5\text{ to }5.5\text{ V}$ ,  $T_{opr} = -30\text{ to }70^\circ\text{C}$ )

Parameter	Oscillator	Frequency	Recommended Oscillator	Recommended Conditions	
				C <sub>1</sub>	C <sub>2</sub>
High-frequency Oscillation	Ceramic Resonator	8 MHz	KYOCERA KBR8.0M	30 pF	30 pF
		4 MHz	KYOCERA KBR4.0MS MURATA CSA4.00MG		
	Crystal Oscillator	8 MHz	TOYOCOM 210B 8.0000	20 pF	20 pF
		4 MHz	TOYOCOM 204B 4.0000		
OSD	LC Resonator	8 MHz	TOKO A285TNIS-11695 (5 mm)	-	-
		7 MHz	TOKO TBEKSES-30375FBY		

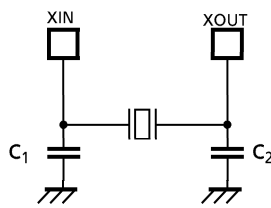

(1) High-frequency

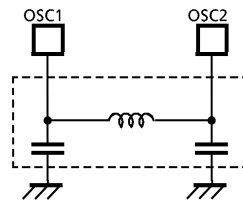

(2) LC Resonator for OSD

*Note :* On our OSD circuit, the horizontal display start position is determined by counting the clock from LC oscillator. So, the unstable start of oscillation after the rising edge of Horizontal Sync. Signal will be cause the OSD distortion. Generally, smaller C and larger L make clearer wave form at the beginning of oscillation. We recommend that the value of LC oscillator should be equal and bigger than 33μH.

*Note :* To keep reliable operation, shield the device electrically with the metal plate on its package mold surface against the high electric field, for example, by CRT (Cathode Ray Tube).