

DATA SHEET

SSTL16857

14-bit SSTL_2 registered driver with differential clock inputs

Product specification
Supersedes data of 1999 Apr 29

1999 Sep 30



PHILIPS

14-bit SSTL_2 registered driver with differential clock inputs

SSTL16857

FEATURES

- Stub-series terminated logic for 2.5V VDDQ (SSTL_2)
- Optimized for DDR (Double Data Rate) SDRAM applications
- Supports SSTL_2 signal inputs and outputs
- Flow-through architecture optimizes PCB layout
- Meets SSTL_2 class I and class II specifications
- Latch-up protection exceeds 500mA per JEDEC Std 17
- ESD protection exceeds 2000 V per MIL STD 833 Method 3015 and 200 V per Machine Model
- Full DDR solution provided when used with PCK857 and CBT3857

DESCRIPTION

The SSTL16857 is a 14-bit SSTL_2 registered driver with differential clock inputs. Both V_{CC} and V_{DDQ} support 2.5V and 3.3V operation however. V_{DDQ} must not exceed V_{CC}. Inputs are SSTL_2 type with V_{REF} normally at 0.5*V_{DDQ}. The outputs support class I which can be used for standard stub-series applications or capacitive loads. Master reset (RESET) asynchronously resets all registers to zero.

The SSTL16857 is intended to be incorporated into standard DIMM (Dual In-Line Memory Module) designs defined by JEDEC, such as DDR (Double Data Rate) SDRAM or SDRAM II Memory Modules. Different from traditional SDRAM, DDR SDRAM transfers data on both clock edges (rising and falling), thus doubling the peak bus bandwidth. A DDR DRAM rated at 100 MHz will have a burst rate of 200 MHz. The modules require between 23 and 27 registered control and address lines, so two 14-bit wide devices will be used on each module. The SSTL16857 is intended to be used for SSTL_2 input and output signals.

The device data inputs consist of differential receivers. One differential input is tied to the input pin while the other is tied to a reference input pad, which is shared by all inputs.

The clock input is fully differential to be compatible with DRAM devices that are installed on the DIMM. However, since the control inputs to the SDRAM change at only half the data rate, the device must only change state on the positive transition of the CLK signal. In order to be able to provide defined outputs from the device even before a stable clock has been supplied, the device must support an asynchronous input pin (reset), which when held to the LOW state will assume that all registers are reset to the LOW state and all outputs drive a LOW signal as well.

QUICK REFERENCE DATA

GND = 0 V; T_{amb} = 25°C; t_r = t_f ≤ 2.5 ns

SYMBOL	PARAMETER	CONDITIONS	TYPICAL	UNIT
t _{PHL} /t _{PLH}	Propagation delay; CLK to Qn	C _L = 30 pF; V _{DDQ} = 2.5 V	1.8	ns
C _I	Input capacitance	V _{CC} = 2.5V	2.9	pF

NOTES:

1. C_{PD} is used to determine the dynamic power dissipation (P_D in μW) $P_D = C_{PD} \times V_{CC}^2 \times f_i + \sum (C_L \times V_{CC}^2 \times f_o)$ where:
 - f_i = input frequency in MHz; C_L = output load capacity in pF; f_o = output frequency in MHz; V_{CC} = supply voltage in V;
 - ∑ (C_L × V_{CC}² × f_o) = sum of the outputs.

PIN CONFIGURATION

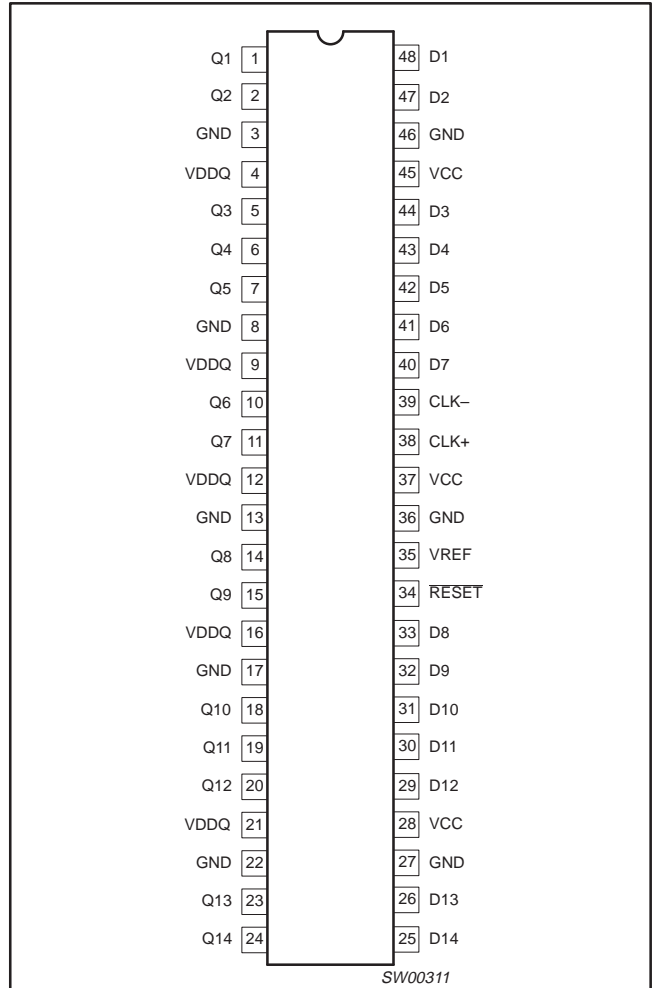

ORDERING INFORMATION

PACKAGES	TEMPERATURE RANGE	ORDER CODE	DWG NUMBER
48-Pin Plastic TSSOP Type I	0°C to +70°C	SSTL16857 DGG	SOT362-1

14-bit SSTL_2 registered driver with differential clock inputs

SSTL16857

PIN DESCRIPTION

PIN NUMBER	SYMBOL	NAME AND FUNCTION
34	RESET	LVC MOS asynchronous master reset (Active LOW)
48, 47, 44, 43, 42, 41, 40, 33, 32, 31, 30, 29, 26, 25	D1 – D14	SSTL_2 data inputs
1, 2, 5, 6, 7, 10, 11, 14, 15, 18, 19, 20, 23, 24	Q1 – Q14	SSTL_2 data outputs
35	VREF	SSTL_2 input reference level
3, 8, 13, 17, 22, 27, 36, 46	GND	Ground (0 V)
28, 37, 45	V _{CC}	Positive supply voltage
4, 9, 12, 16, 21	V _{DDQ}	Output supply voltage
38 39	CLK+ CLK-	Differential clock inputs

FUNCTION TABLE

INPUTS				OUTPUT
RESET	CLK	CLK	D	Q
L	X	X	X	L
H	↓	↑	H	H
H	↓	↑	L	L
H	L or H	L or H	X	Q ₀

H = High voltage level
 L = High voltage level
 ↓ = High-to-Low transition
 ↑ = Low-to-High transition
 X = Don't care

LOGIC DIAGRAM

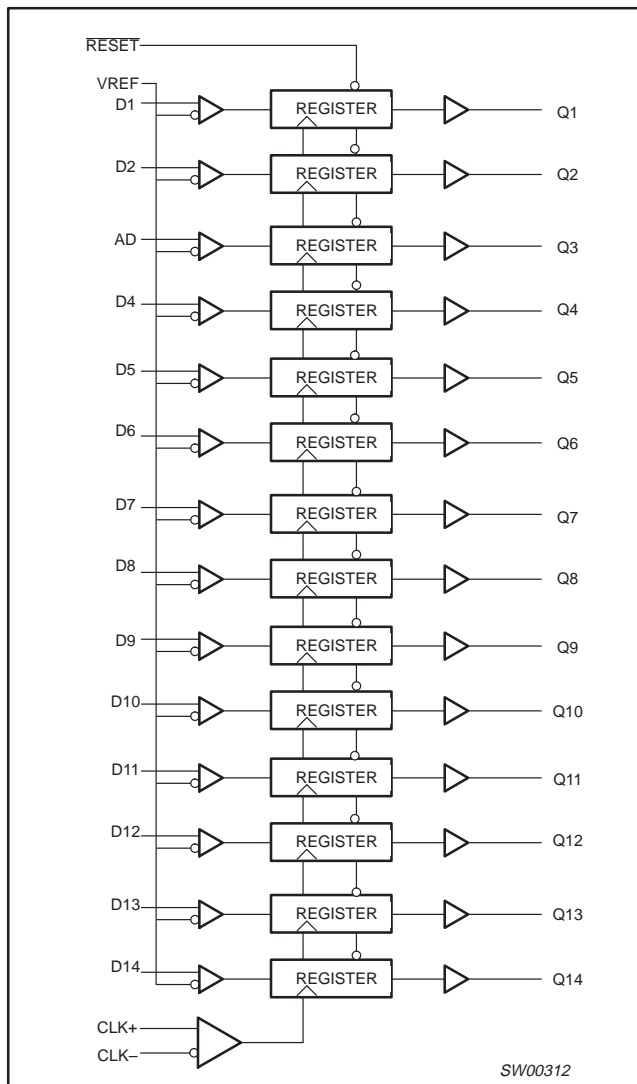

ABSOLUTE MAXIMUM RATINGS^{1, 2}

SYMBOL	PARAMETER	CONDITION	LIMITS		UNIT
			MIN	MAX	
V _{CC}	DC supply voltage		-0.5	+4.6	V
I _{IK}	DC input diode current	V _I < 0		-50	mA
V _I	DC input voltage ³		-0.5	V _{DDQ} + 0.5	V
I _{OK}	DC output diode current	V _O < 0		-50	mA
V _{OUT}	DC output voltage ³	Note 3	-0.5	V _{DDQ} + 0.5	V
I _{OUT}	DC output current	V _O = 0 to V _{DDQ}		±50	mA
	Continuous current ⁴	V _{CC} , V _{DDQ} , or GND		±100	
T _{STG}	Storage temperature range		-65	+150	°C

NOTES:

- Stresses beyond those listed may cause permanent damage to the device. These are stress ratings only and functional operation of the device at these or any other conditions beyond those indicated under "recommended operating conditions" is not implied. Exposure to absolute-maximum-rated conditions for extended periods may affect device reliability.
- The performance capability of a high-performance integrated circuit in conjunction with its thermal environment can create junction temperatures which are detrimental to reliability. The maximum junction temperature of this integrated circuit should not exceed 150°C.
- The input and output voltage ratings may be exceeded if the input and output current ratings are observed.
- The continuous current at V_{CC}, V_{DDQ}, or GND should not exceed ±100 mA.

14-bit SSTL_2 registered driver with differential clock inputs

SSTL16857

RECOMMENDED OPERATING CONDITIONS¹

SYMBOL	PARAMETER	TEST CONDITIONS	MIN	TYP	MAX	UNIT
V _{CC}	Supply voltage		V _{DDQ}		3.6	V
V _{DDQ}	Output supply voltage		2.3		2.7	V
V _{REF}	Reference voltage (V _{REF} = 0.5 × V _{DDQ})		1.15	1.25	1.35	V
V _{TT}	Termination voltage		V _{REF} – 40mV	V _{REF}	V _{REF} + 40mV	V
V _I	Input voltage		0		V _{CC}	V
V _{IH}	AC HIGH-level input voltage	All inputs	V _{REF} + 350mV			V
V _{IL}	AC LOW-level input voltage	All inputs			V _{REF} – 350mV	V
V _{IH}	DC HIGH-level input voltage	All inputs	V _{REF} + 180mV		V _{DDQ} + 0.5V	V
V _{IL}	DC LOW-level input voltage	All inputs	V _{SS} – 0.5V		V _{REF} – 180mV	V
I _{OH}	HIGH-level output current				–20	mA
I _{OL}	LOW-level output current				20	mA
T _{amb}	Operating free-air temperature range		0		70	°C

NOTE:

1. Unused control inputs must be held HIGH or LOW to prevent them from floating.

DC ELECTRICAL CHARACTERISTICS

Over recommended operating conditions. Voltages are referenced to GND (ground = 0V).

SYMBOL	PARAMETER	TEST CONDITIONS	LIMITS			UNIT	
			Temp = 0°C to +70°C				
			MIN	TYP ²	MAX		
V _{IK}	I/O supply voltage	V _{CC} = 2.3V; I _I = –18mA			–1.2	V	
V _{OH}	HIGH level output voltage	V _{CC} = 2.3V to 2.7V; I _{OH} = –100μA	V _{CC} – 0.2	2.3			
		V _{CC} = 2.3V; I _{OH} = –8mA	1.95	2.2			
		V _{CC} = 2.3V; I _{OH} = –16mA	1.95	2.1			
V _{OL}	LOW level output voltage	V _{CC} = 2.3V to 2.7V; I _{OL} = –100μA		0.002	0.2		
		V _{CC} = 2.3V; I _{OL} = –8mA		0.14	0.35		
		V _{CC} = 2.3V; I _{OL} = –16mA		0.30	0.35		
V _{CMR}	CLK, $\overline{\text{CLK}}$	Common mode range for reliable performance	0.97		1.53	V	
V _{PP}	CLK, $\overline{\text{CLK}}$	Minimum peak-to-peak input to ensure logic state	360			mV	
I _I	Data inputs, $\overline{\text{RESET}}$	V _{CC} = 2.7V; V _I = 1.7V or 0.8V	V _{REF} = 1.15V or 1.35V		0.01	±5	μA
		V _{CC} = 2.7V; V _I = 2.7V or 0V			0.01	±5	
		V _{CC} = 3.6V; V _I = 1.7V or 0.8V			0.01	±5	
		V _{CC} = 3.6V; V _I = 2.7V or 0V			0.01	±5	
	CLK, $\overline{\text{CLK}}$	V _{CC} = 2.7V; V _I = 1.7V or 0.8V	V _{REF} = 1.15V or 1.35V		0.05	±5	μA
		V _{CC} = 2.7V; V _I = 2.7V or 0V			0.05	±5	
		V _{CC} = 3.6V; V _I = 1.7V or 0.8V			0.05	±5	mA
		V _{CC} = 3.6V; V _I = 2.7V or 0V			0.05	±5	
	V _{REF}	V _{CC} = 2.7V	V _{REF} = 1.15V or 1.35V		0.05	±5	μA
		V _{CC} = 3.6V			0.05	±5	
	I _{CC}	Quiescent supply current CLK and $\overline{\text{CLK}}$ in opposite state ¹	V _{CC} = 2.7V; V _I = 1.7V or 0.8V		12	25	mA
			V _{CC} = 2.7V; V _I = 2.7V or 0V		10	25	
V _{CC} = 3.6V; V _I = 1.7V or 0.8V				12	25		
V _{CC} = 3.6V; V _I = 2.7V or 0V				10	25		

NOTES:

- When CLK and $\overline{\text{CLK}}$ are HIGH, typical I_{CC} = 25mA.
- All typical values are at V_{CC} = 3.3V and T_{amb} = 25°C (unless otherwise specified).

14-bit SSTL_2 registered driver with differential clock inputs

SSTL16857

TIMING REQUIREMENTS

Over recommended operating conditions; $T_{amb} = 0^{\circ}\text{C}$ to $+70^{\circ}\text{C}$ (unless otherwise noted) (see Figure 1)

SYMBOL	PARAMETER	TEST CONDITIONS	LIMITS				UNIT
			$V_{CC} = 2.5V \pm 0.2V$		$V_{CC} = 3.3V \pm 0.3V$		
			MIN	MAX	MIN	MAX	
f_{clock}	Clock frequency		200		200	MHz	
t_w	Pulse duration, CLK, \overline{CLK} HIGH or LOW		1.0		1.0	ns	
t_{su}	Setup time	Data before $CLK\uparrow, \overline{CLK}\downarrow$	0.8		0.9	ns	
		RESET HIGH before $CLK\uparrow, \overline{CLK}\downarrow$	0.8		1.0		
t_h	Hold time		0.5		0.5	ns	

SWITCHING CHARACTERISTICS

Over recommended operating conditions; $T_{amb} = 0^{\circ}\text{C}$ to $+70^{\circ}\text{C}$; $V_{DDQ} = 2.3 - 2.7V$ and V_{DDQ} does not exceed V_{CC} .

Class I, $V_{REF} = V_{TT} = V_{DDQ} \times 0.5$ and $C_L = 10pF$ (unless otherwise noted) (see Figure 1)

SYMBOL	FROM (INPUT)	TO (OUTPUT)	LIMITS		LIMITS		UNIT
			$V_{CC} = 2.5V \pm 0.2V$		$V_{CC} = 3.3V \pm 0.3V$		
			MIN	MAX	MIN	MAX	
f_{max}	Maximum clock frequency		200		200	MHz	
t_{PLH}/t_{PHL}	CLK and \overline{CLK}	Q	1.0	3.1	0.7	2.6	ns
t_{PHL}	RESET	Q	2.0	5.0	1.4	4.0	ns

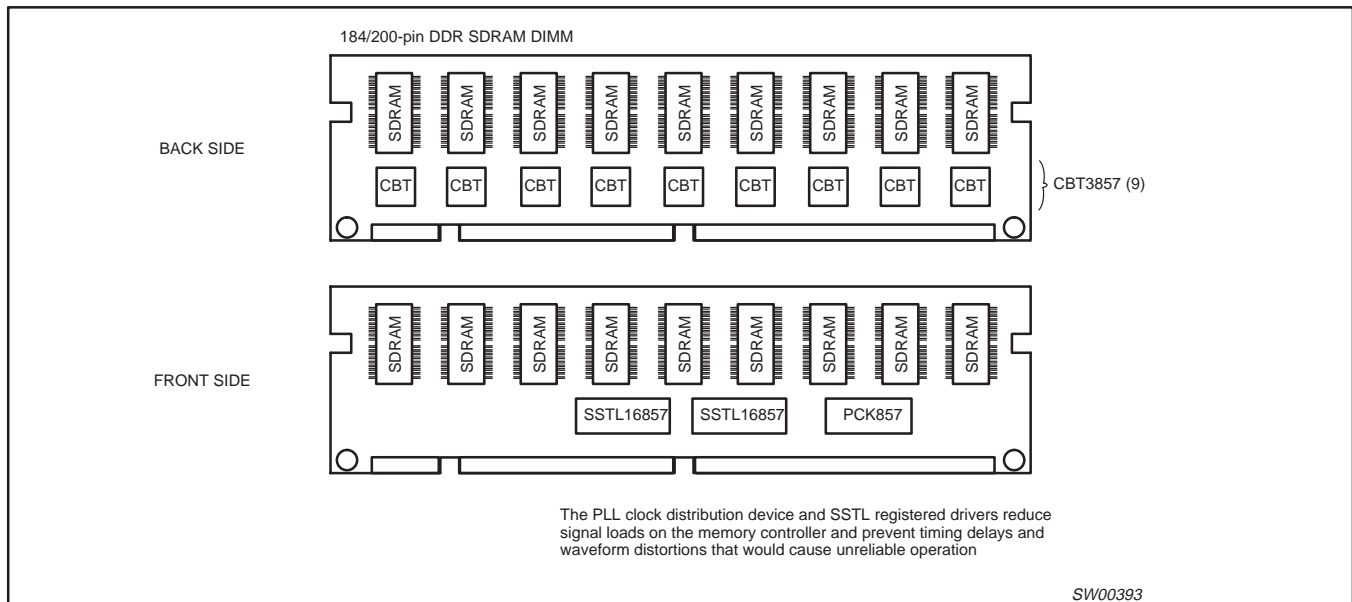

14-bit SSTL_2 registered driver with differential clock inputs

SSTL16857

PARAMETER MEASUREMENT INFORMATION

AC WAVEFORMS

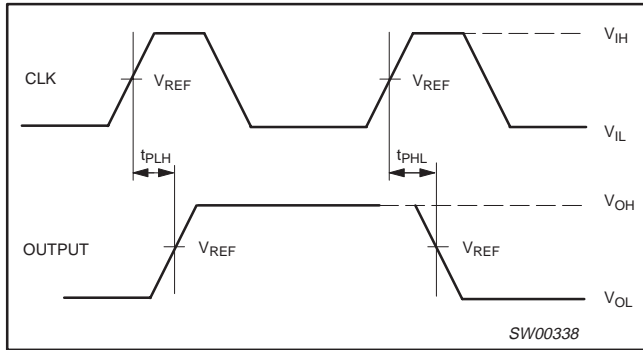

Waveform 1. Propagation delay times inverting and non-inverting outputs

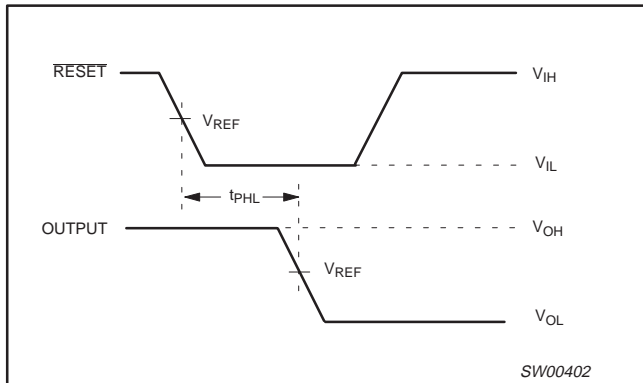

Waveform 2. Propagation delay RESET to output.

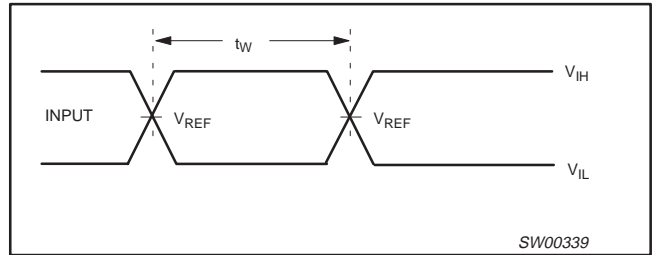

Waveform 3. Pulse duration

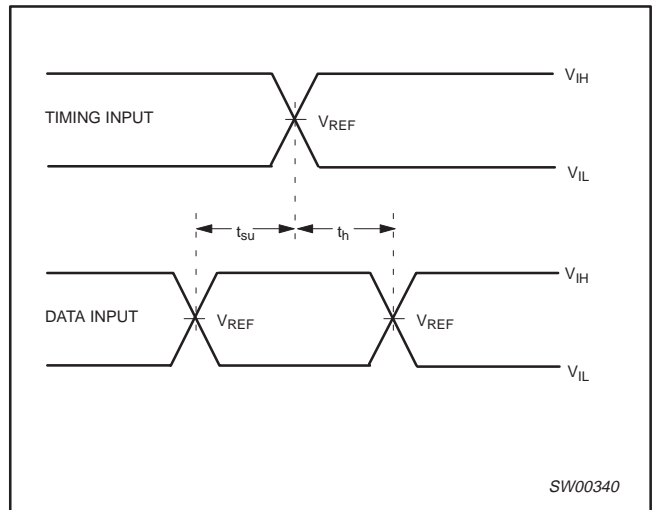

Waveform 4. Setup and hold times

TEST CIRCUIT

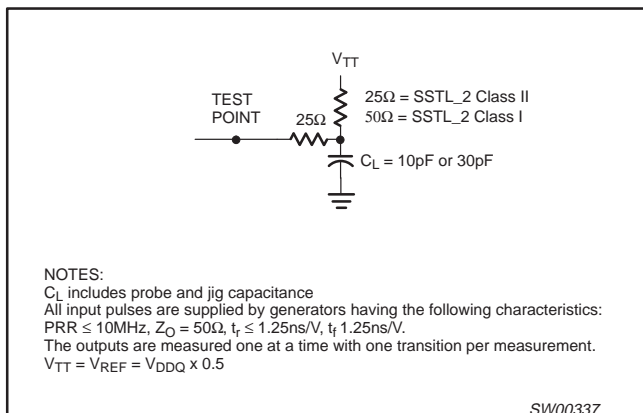

Figure 1. Load circuitry

NOTES:
 C_L includes probe and jig capacitance
 All input pulses are supplied by generators having the following characteristics:
 $PRR \leq 10\text{MHz}$, $Z_O = 50\Omega$, $t_r \leq 1.25\text{ns/V}$, $t_f \leq 1.25\text{ns/V}$.
 The outputs are measured one at a time with one transition per measurement.
 $V_{TT} = V_{REF} = V_{DDQ} \times 0.5$

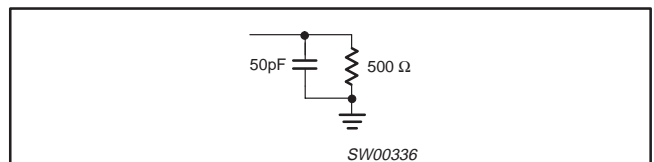

Figure 2.

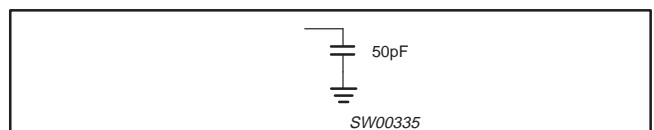

Figure 3.

14-bit SSTL_2 registered driver with differential clock inputs

SSTL16857

TSSOP48: plastic thin shrink small outline package; 48 leads; body width 6.1mm

SOT362-1

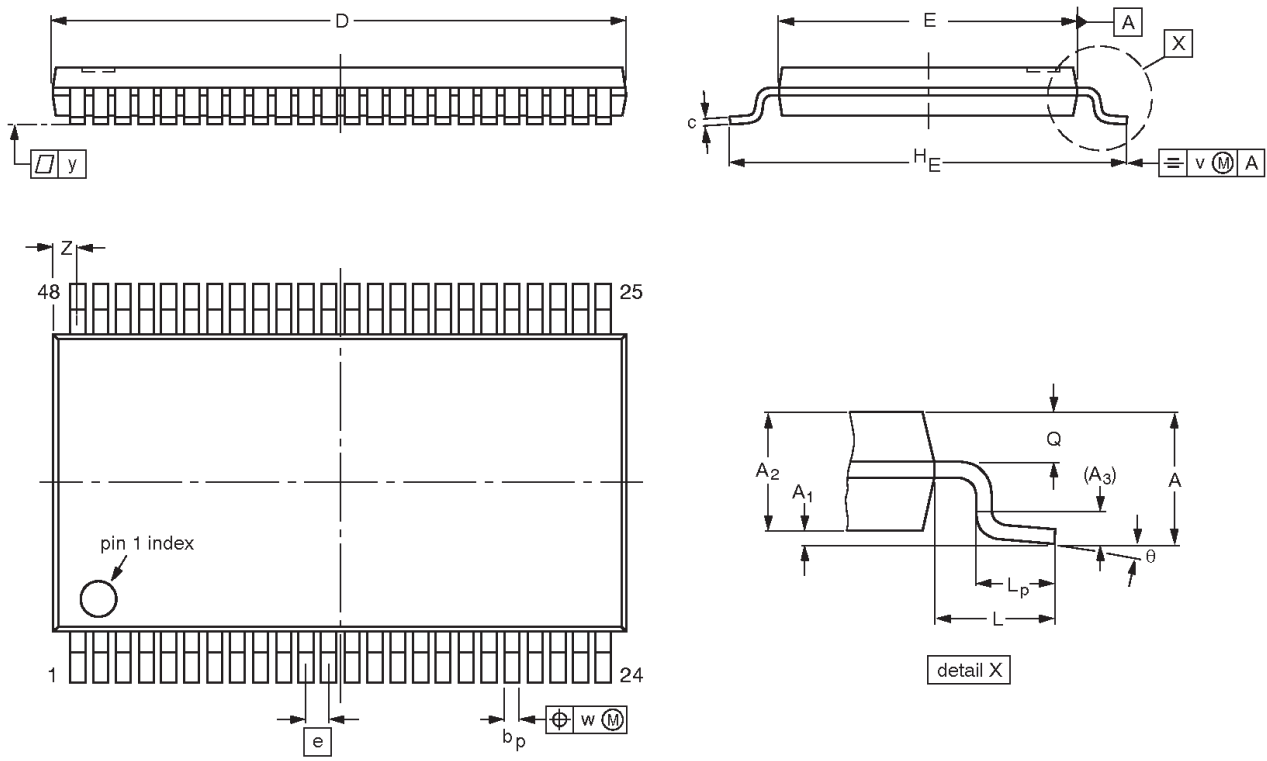

DIMENSIONS (mm are the original dimensions).

UNIT	A max.	A ₁	A ₂	A ₃	b _p	c	D ⁽¹⁾	E ⁽²⁾	e	H _E	L	L _p	Q	v	w	y	Z	θ
mm	1.2	0.15 0.05	1.05 0.85	0.25	0.28 0.17	0.2 0.1	12.6 12.4	6.2 6.0	0.5	8.3 7.9	1	0.8 0.4	0.50 0.35	0.25	0.08	0.1	0.8 0.4	8° 0°

Notes

1. Plastic or metal protrusions of 0.15 mm maximum per side are not included.
2. Plastic interlead protrusions of 0.25 mm maximum per side are not included.

OUTLINE VERSION	REFERENCES				EUROPEAN PROJECTION	ISSUE DATE
	IEC	JEDEC	EIAJ			
SOT362-1		MO-153ED				93-02-03 95-02-10

14-bit SSTL_2 registered driver with differential clock inputs

SSTL16857

Data sheet status

Data sheet status	Product status	Definition [1]
Objective specification	Development	This data sheet contains the design target or goal specifications for product development. Specification may change in any manner without notice.
Preliminary specification	Qualification	This data sheet contains preliminary data, and supplementary data will be published at a later date. Philips Semiconductors reserves the right to make changes at any time without notice in order to improve design and supply the best possible product.
Product specification	Production	This data sheet contains final specifications. Philips Semiconductors reserves the right to make changes at any time without notice in order to improve design and supply the best possible product.

[1] Please consult the most recently issued datasheet before initiating or completing a design.

Definitions

Short-form specification — The data in a short-form specification is extracted from a full data sheet with the same type number and title. For detailed information see the relevant data sheet or data handbook.

Limiting values definition — Limiting values given are in accordance with the Absolute Maximum Rating System (IEC 134). Stress above one or more of the limiting values may cause permanent damage to the device. These are stress ratings only and operation of the device at these or at any other conditions above those given in the Characteristics sections of the specification is not implied. Exposure to limiting values for extended periods may affect device reliability.

Application information — Applications that are described herein for any of these products are for illustrative purposes only. Philips Semiconductors make no representation or warranty that such applications will be suitable for the specified use without further testing or modification.

Disclaimers

Life support — These products are not designed for use in life support appliances, devices or systems where malfunction of these products can reasonably be expected to result in personal injury. Philips Semiconductors customers using or selling these products for use in such applications do so at their own risk and agree to fully indemnify Philips Semiconductors for any damages resulting from such application.

Right to make changes — Philips Semiconductors reserves the right to make changes, without notice, in the products, including circuits, standard cells, and/or software, described or contained herein in order to improve design and/or performance. Philips Semiconductors assumes no responsibility or liability for the use of any of these products, conveys no license or title under any patent, copyright, or mask work right to these products, and makes no representations or warranties that these products are free from patent, copyright, or mask work right infringement, unless otherwise specified.

Philips Semiconductors
811 East Arques Avenue
P.O. Box 3409
Sunnyvale, California 94088-3409
Telephone 800-234-7381

© Copyright Philips Electronics North America Corporation 1999
All rights reserved. Printed in U.S.A.

Date of release: 09-99

Document order number:

9397-750-06455

Let's make things better.