

# DATA SHEET

## P87LPC759

Low power, low price, low pin count  
(14 pin) microcontroller with 1 kbyte OTP

Preliminary data

2002 Mar 21

# Low power, low price, low pin count (14 pin) microcontroller with 1 kbyte OTP

## P87LPC759

<b>GENERAL DESCRIPTION</b> .....	<b>1</b>
<b>ORDERING INFORMATION</b> .....	<b>1</b>
<b>PINNING INFORMATION</b> .....	<b>1</b>
<b>LOGIC SYMBOL</b> .....	<b>2</b>
<b>BLOCK DIAGRAM</b> .....	<b>3</b>
<b>PIN DESCRIPTION</b> .....	<b>5</b>
<b>SPECIAL FUNCTION REGISTERS</b> .....	<b>6</b>
<b>FUNCTIONAL DESCRIPTION</b> .....	<b>8</b>
Enhanced CPU .....	8
Interrupts .....	8
External Interrupt Inputs .....	9
I/O Ports .....	10
Quasi-Bidirectional Output Configuration .....	10
Open Drain Output Configuration .....	11
Push-Pull Output Configuration .....	11
Keyboard Interrupt (KBI) .....	12
Oscillator .....	14
Low Frequency Oscillator Option .....	14
Medium Frequency Oscillator Option .....	14
High Frequency Oscillator Option .....	14
On-Chip RC Oscillator Option .....	14
External Clock Input Option .....	14
Clock Output .....	14
CPU Clock Modification: CLKR and DIVM .....	16
Power Monitoring Functions .....	16
Brownout Detection .....	16
Power On Detection .....	17
Power Reduction Modes .....	17
Idle Mode .....	17
Power Down Mode .....	17
Low Voltage EPROM Operation .....	19
Reset .....	19
Timer/Counters .....	20
Mode 0 .....	21
Mode 1 .....	22
Mode 2 .....	22
Mode 3 .....	22
Timer Overflow Toggle Output .....	24
Watchdog Timer .....	24
Watchdog Feed Sequence .....	24
Watchdog Reset .....	24
Additional Features .....	26
Software Reset .....	26
Dual Data Pointers .....	26
EPROM Characteristics .....	27
System Configuration Bytes .....	27
Security Bits .....	28
<b>ABSOLUTE MAXIMUM RATINGS</b> .....	<b>29</b>
<b>DC ELECTRICAL CHARACTERISTICS</b> .....	<b>30</b>
<b>AC ELECTRICAL CHARACTERISTICS</b> .....	<b>31</b>
<b>REVISION HISTORY</b> .....	<b>35</b>

## Low power, low price, low pin count (14 pin) microcontroller with 1 kbyte OTP

## P87LPC759

### GENERAL DESCRIPTION

The P87LPC759 is a 14-pin single-chip microcontroller designed for low pin count applications demanding high-integration, low cost solutions over a wide range of performance requirements. A member of the Philips low pin count family, the P87LPC759 offers programmable oscillator configurations for high and low speed crystals or RC operation, wide operating voltage range, programmable port output configurations, selectable Schmitt trigger inputs, LED drive outputs, and a built-in watchdog timer. The P87LPC759 is based on an accelerated 80C51 processor architecture that executes instructions at twice the rate of standard 80C51 devices.

### FEATURES

- An accelerated 80C51 CPU provides instruction cycle times of 300–600 ns for all instructions except multiply and divide when executing at 20 MHz. Execution at up to 20 MHz when  $V_{DD} = 4.5\text{ V to }6.0\text{ V}$ , 10 MHz when  $V_{DD} = 2.7\text{ V to }6.0\text{ V}$
- 2.7 V to 6.0 V operating range for digital functions
- 1 kbyte EPROM code memory
- 64 byte RAM data memory
- Two 16-bit counter/timers. One timer may be configured to toggle a port output upon timer overflow
- Four keypad interrupt inputs, plus one additional external interrupt input
- Four interrupt priority levels
- Watchdog timer with separate on-chip oscillator, requiring no external components. The watchdog timeout time is selectable from 8 values
- Active low reset. On-chip power-on reset allows operation with no external reset components
- Low voltage reset. One of two preset low voltage levels may be selected to allow a graceful system shutdown when power fails. May optionally be configured as an interrupt
- Oscillator Fail Detect. The watchdog timer has a separate fully on-chip oscillator, allowing it to perform an oscillator fail detect function
- Configurable on-chip oscillator with frequency range and RC oscillator options (selected by user programmed EPROM bits). The RC oscillator option allows operation with no external oscillator components
- Programmable port output configuration options: quasi-bidirectional, open drain, push-pull, input-only
- Selectable Schmitt trigger port inputs
- LED drive capability (20 mA) on all port pins
- Controlled slew rate port outputs to reduce EMI. Outputs have approximately 10 ns minimum ramp times
- Nine I/O pins minimum. Up to 12 I/O pins using on-chip oscillator and reset options
- Only power and ground connections are required to operate the P87LPC759 when fully on-chip oscillator and reset options are selected
- Serial EPROM programming allows simple in-circuit production coding. Two EPROM security bits prevent reading of sensitive application programs
- Idle and Power Down reduced power modes. Improved wakeup from Power Down mode (a low interrupt input starts execution). Typical Power Down current is 1  $\mu\text{A}$
- 14-pin DIP package

### ORDERING INFORMATION

Part Number	Temperature Range °C and Package	Frequency	Drawing Number
P87LPC759BN	0 to +70, plastic dual in-line package; 14 leads (300 mil)	20 MHz (5 V), 10 MHz (3 V)	SOT27-1

### PINNING INFORMATION

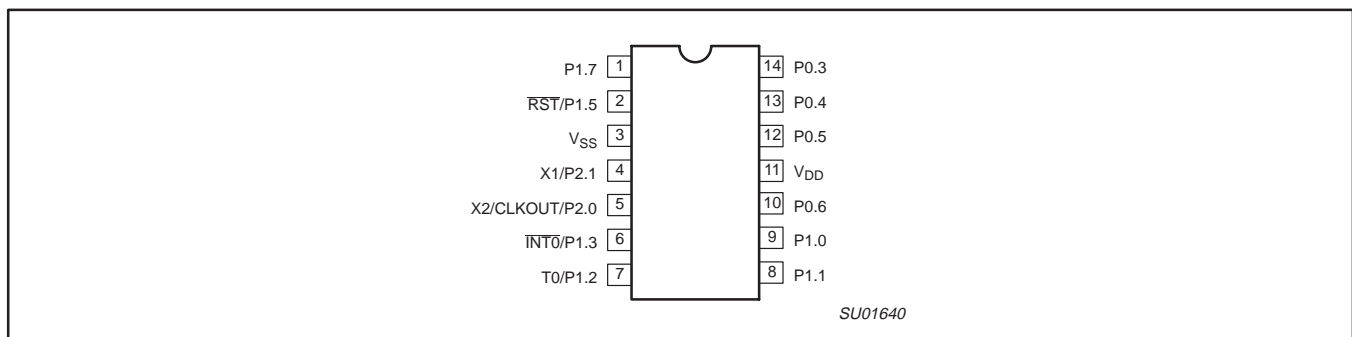

Low power, low price, low pin count (14 pin)  
microcontroller with 1 kbyte OTP

P87LPC759

**LOGIC SYMBOL**

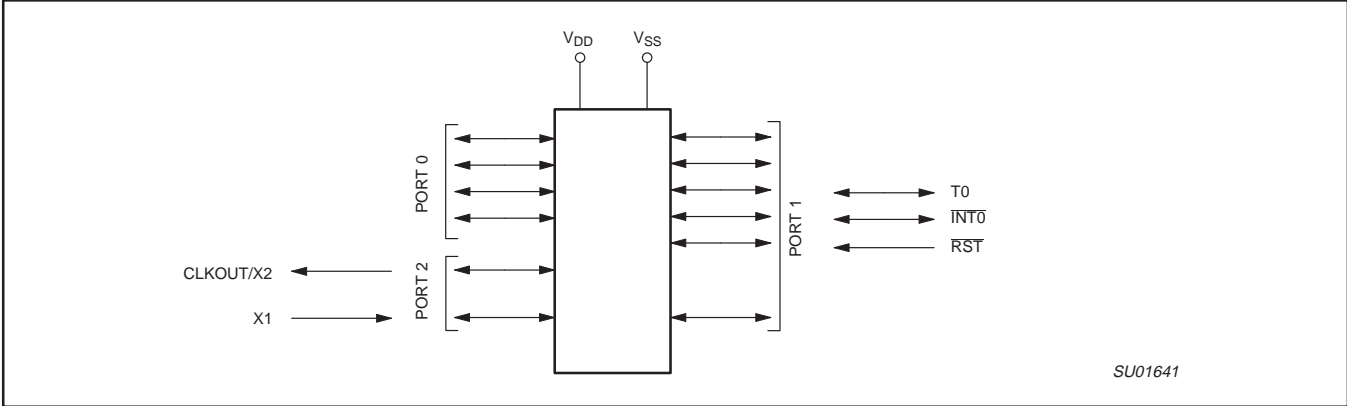

Low power, low price, low pin count (14 pin)  
microcontroller with 1 kbyte OTP

P87LPC759

BLOCK DIAGRAM

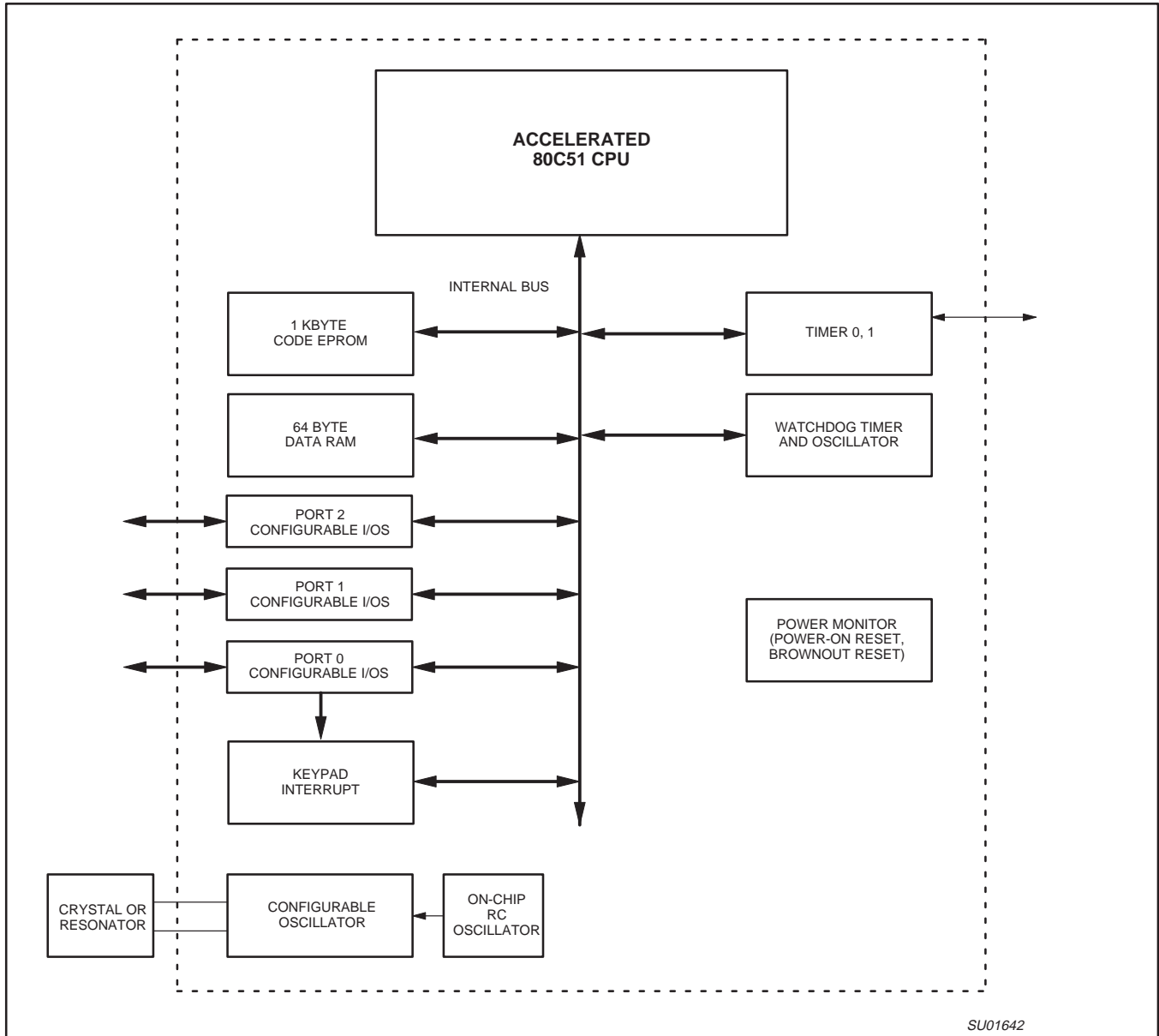

Low power, low price, low pin count (14 pin)  
microcontroller with 1 kbyte OTP

P87LPC759

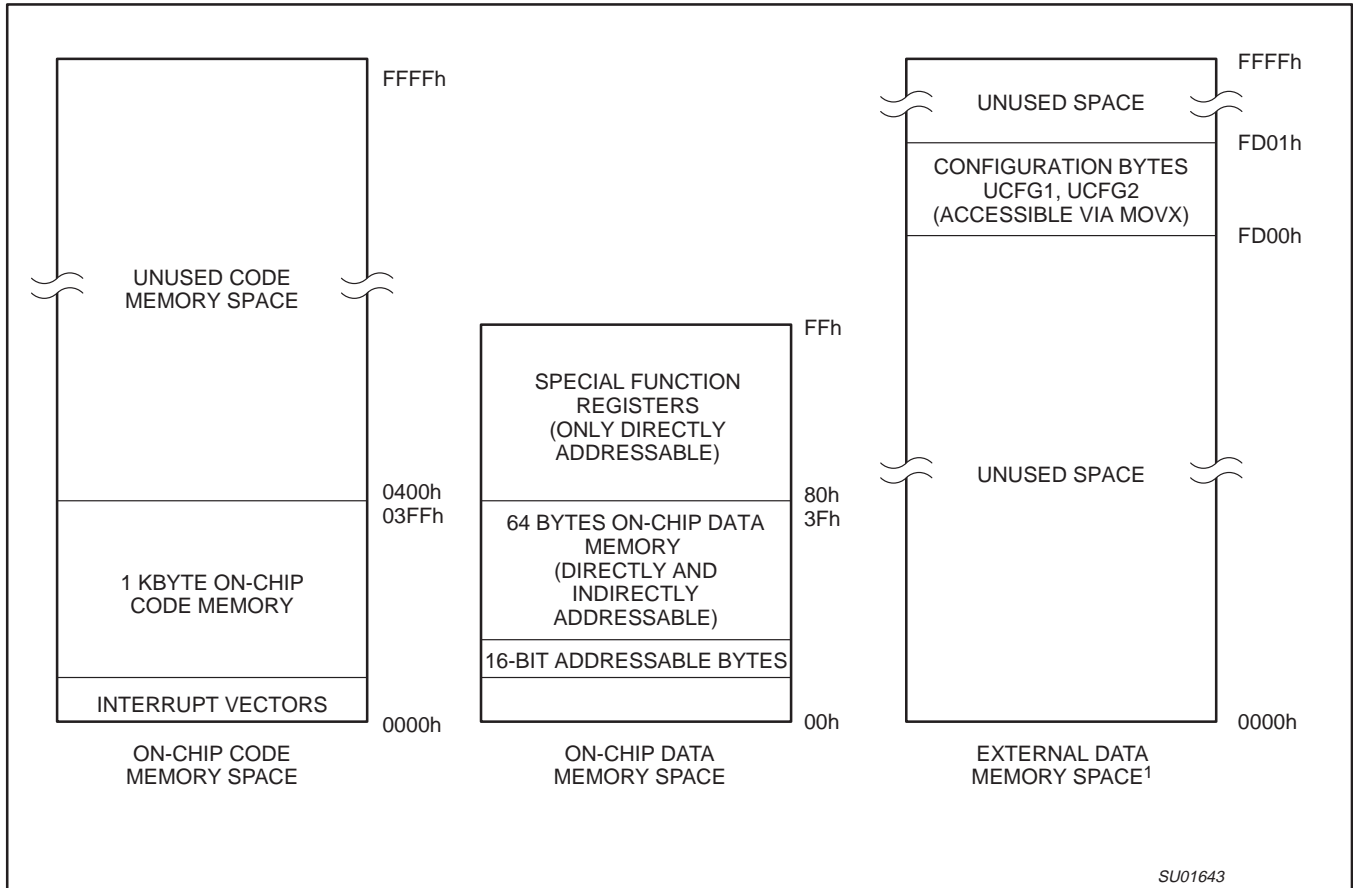

1. The P87LPC759 does not support access to external data memory. However, the User Configuration Bytes are accessed via the MOVX instruction as if they were in external data memory.

**Figure 1. P87LPC759 Program and Data Memory Map**

# Low power, low price, low pin count (14 pin) microcontroller with 1 kbyte OTP

P87LPC759

## PIN DESCRIPTION

MNEMONIC	PIN NO.	TYPE	NAME AND FUNCTION
P0.3–P0.6	10, 12–14	I/O	<p><b>Port 0:</b> Port 0 is a 4-bit I/O port with a user-configurable output type. Port 0 latches are configured in the quasi-bidirectional mode and have either ones or zeros written to them during reset, as determined by the PRHI bit in the UCFG1 configuration byte. The operation of port 0 pins as inputs and outputs depends upon the port configuration selected. Each port pin is configured independently. Refer to the section on I/O port configuration and the DC Electrical Characteristics for details.</p> <p>The Keyboard Interrupt feature operates with port 0 pins.</p>
P1.0–P1.3 P1.5, P1.7	1–2 6–9	I/O	<p><b>Port 1:</b> Port 1 is an 6-bit I/O port with a user-configurable output type, except for three pins as noted below. Port 1 latches are configured in the quasi-bidirectional mode and have either ones or zeros written to them during reset, as determined by the PRHI bit in the UCFG1 configuration byte. The operation of the configurable port 1 pins as inputs and outputs depends upon the port configuration selected. Each of the configurable port pins are programmed independently. Refer to the section on I/O port configuration and the DC Electrical Characteristics for details.</p> <p>Port 1 also provides various special functions as described below.</p>
	7	I/O O	<p><b>P1.2 T0</b> Timer/counter 0 external count input or overflow output. When configured as an output, P1.2 is open drain.</p>
	6	I O	<p><b>P1.3 <math>\overline{\text{INT0}}</math></b> External interrupt 0 input. When configured as an output, P1.3 is open drain.</p>
	2	I	<p><b>P1.5 RST</b> External Reset input (if selected via EPROM configuration). A low on this pin resets the microcontroller, causing I/O ports and peripherals to take on their default states, and the processor begins execution at address 0. When used as a port pin, P1.5 is a Schmitt trigger input only.</p>
P2.0–P2.1	4, 5	I/O	<p><b>Port 2:</b> Port 2 is a 2-bit I/O port with a user-configurable output type. Port 2 latches are configured in the quasi-bidirectional mode and have either ones or zeros written to them during reset, as determined by the PRHI bit in the UCFG1 configuration byte. The operation of port 2 pins as inputs and outputs depends upon the port configuration selected. Each port pin is configured independently. Refer to the section on I/O port configuration and the DC Electrical Characteristics for details.</p> <p>Port 2 also provides various special functions as described below.</p>
	5	O	<p><b>P2.0 X2</b> Output from the oscillator amplifier (when a crystal oscillator option is selected via the EPROM configuration).</p> <p><b>CLKOUT</b> CPU clock divided by 6 clock output when enabled via SFR bit and in conjunction with internal RC oscillator or external clock input.</p>
	4	I	<p><b>P2.1 X1</b> Input to the oscillator circuit and internal clock generator circuits (when selected via the EPROM configuration).</p>
V <sub>SS</sub>	3	I	<b>Ground:</b> 0 V reference.
V <sub>DD</sub>	11	I	<b>Power Supply:</b> This is the power supply voltage for normal operation as well as Idle and Power Down modes.





# Low power, low price, low pin count (14 pin) microcontroller with 1 kbyte OTP

## P87LPC759

Name	Description	SFR Address	Bit Functions and Addresses								Reset Value
			MSB				LSB				
TH1	Timer 1 high byte	8Dh									00h
TL0	Timer 0 low byte	8Ah									00h
TL1	Timer 1 low byte	8Bh									00h
TMOD	Timer 0 and 1 mode	89h	–	–	M1	M0	GATE	C/T	M1	M0	00h
WDCON#	Watchdog control register	A7h	–	–	WDOVF	WDRUN	WDCLK	WDS2	WDS1	WDS0	Note 4
WDRST#	Watchdog reset register	A6h									XXh

### NOTES:

\* SFRs are bit addressable.

# SFRs are modified from or added to the 80C51 SFRs.

1. Unimplemented bits in SFRs are X (unknown) at all times. Ones should not be written to these bits since they may be used for other purposes in future derivatives. The reset value shown in the table for these bits is 0.
2. I/O port values at reset are determined by the PRHI bit in the UCFG1 configuration byte.
3. The PCON reset value is x x BOF POF–0 0 0 0b. The BOF and POF flags are not affected by reset. The POF flag is set by hardware upon power up. The BOF flag is set by the occurrence of a brownout reset/interrupt and upon power up.
4. The WDCON reset value is xx11 0000b for a Watchdog reset, xx01 0000b for all other reset causes if the watchdog is enabled, and xx00 0000b for all other reset causes if the watchdog is disabled.

---

Low power, low price, low pin count (14 pin)  
microcontroller with 1 kbyte OTP

---

P87LPC759

**FUNCTIONAL DESCRIPTION**

# Low power, low price, low pin count (14 pin) microcontroller with 1 kbyte OTP

## P87LPC759

### External Interrupt Inputs

The P87LPC759 has one individual interrupt input as well as the Keyboard Interrupt function. The latter is described separately in this section. The interrupt input is identical to those present on the standard 80C51 microcontroller.

The external source can be programmed to be level-activated or transition-activated by setting or clearing bit IT0 in Register TCON. If IT0 = 0, external interrupt 0 is triggered by a detected low at the INT0 pin. If IT0 = 1, external interrupt 0 is edge triggered. In this mode if successive samples of the INT0 pin show a high in one cycle and a low in the next cycle, interrupt request flag IE0 in TCON is set, causing an interrupt request.

Since the external interrupt pin is sampled once each machine cycle, an input high or low should hold for at least 6 CPU Clocks to ensure proper sampling. If the external interrupt is

transition-activated, the external source has to hold the request pin high for at least one machine cycle, and then hold it low for at least one machine cycle. This is to ensure that the transition is detected and that interrupt request flag IE0 is set. IE0 is automatically cleared by the CPU when the service routine is called.

If the external interrupt is level-activated, the external source must hold the request active until the requested interrupt is actually generated. If the external interrupt is still asserted when the interrupt service routine is completed another interrupt will be generated. It is not necessary to clear the interrupt flag IE0 when the interrupt is level sensitive, it simply tracks the input pin level.

If the external interrupt is enabled when the P87LPC759 is put into Power Down or Idle mode, the interrupt will cause the processor to wake up and resume operation. Refer to the section on Power Reduction Modes for details.

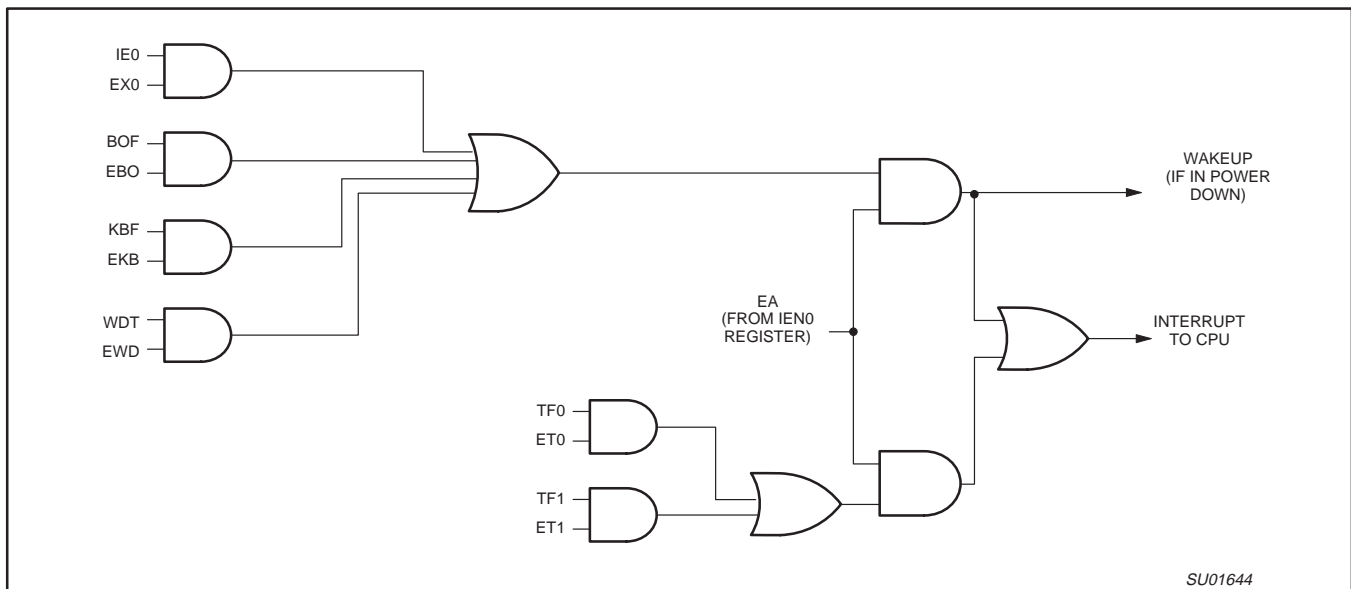

Figure 2. Interrupt Sources, Interrupt Enables, and Power Down Wakeup Sources

SU01644



# Low power, low price, low pin count (14 pin) microcontroller with 1 kbyte OTP

## P87LPC759

### Open Drain Output Configuration

The open drain output configuration turns off all pull-ups and only drives the pull-down transistor of the port driver when the port latch contains a logic 0. To be used as a logic output, a port configured in this manner must have an external pull-up, typically a resistor tied to  $V_{DD}$ . The pull-down for this mode is the same as for the quasi-bidirectional mode.

The open drain port configuration is shown in Figure 4.

### Push-Pull Output Configuration

The push-pull output configuration has the same pull-down structure as both the open drain and the quasi-bidirectional output modes, but provides a continuous strong pull-up when the port latch contains a logic 1. The push-pull mode may be used when more source current is needed from a port output.

The push-pull port configuration is shown in Figure 5.

The three port pins that cannot be configured are P1.2, P1.3, and P1.5. The port pins P1.2 and P1.3 are permanently configured as open drain outputs. They may be used as inputs by writing ones to their respective port latches. P1.5 may be used as a Schmitt trigger input if the P87LPC759 has been configured for an internal reset and is not using the external reset input function  $RST$ .

Additionally, port pins P2.0 and P2.1 are disabled for both input and output if one of the crystal oscillator options is chosen. Those options are described in the Oscillator section.

The value of port pins at reset is determined by the PRHI bit in the UCFG1 register. Ports may be configured to reset high or low as needed for the application. When port pins are driven high at reset, they are in quasi-bidirectional mode and therefore do not source large amounts of current.

Every output on the P87LPC759 may potentially be used as a 20 mA sink LED drive output. However, there is a maximum total output current for all ports which must not be exceeded.

All ports pins of the P87LPC759 have slew rate controlled outputs. This is to limit noise generated by quickly switching output signals. The slew rate is factory set to approximately 10 ns rise and fall times.

The bits in the P2M1 register that are not used to control configuration of P2.1 and P2.0 are used for other purposes. These bits can enable Schmitt trigger inputs on each I/O port, enable toggle outputs from Timer 0 and Timer 1, and enable a clock output if either the internal RC oscillator or external clock input is being used. The last two functions are described in the Timer/Counters and Oscillator sections respectively. The enable bits for all of these functions are shown in Figure 6.

Each I/O port of the P87LPC759 may be selected to use TTL level inputs or Schmitt inputs with hysteresis. A single configuration bit determines this selection for the entire port. Port pins P1.2, P1.3, and P1.5 always have a Schmitt trigger input.

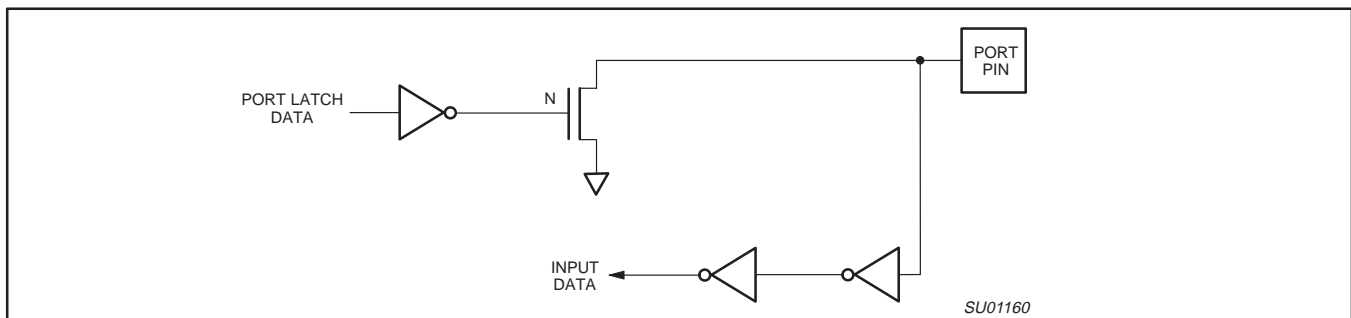

Figure 4. Open Drain Output

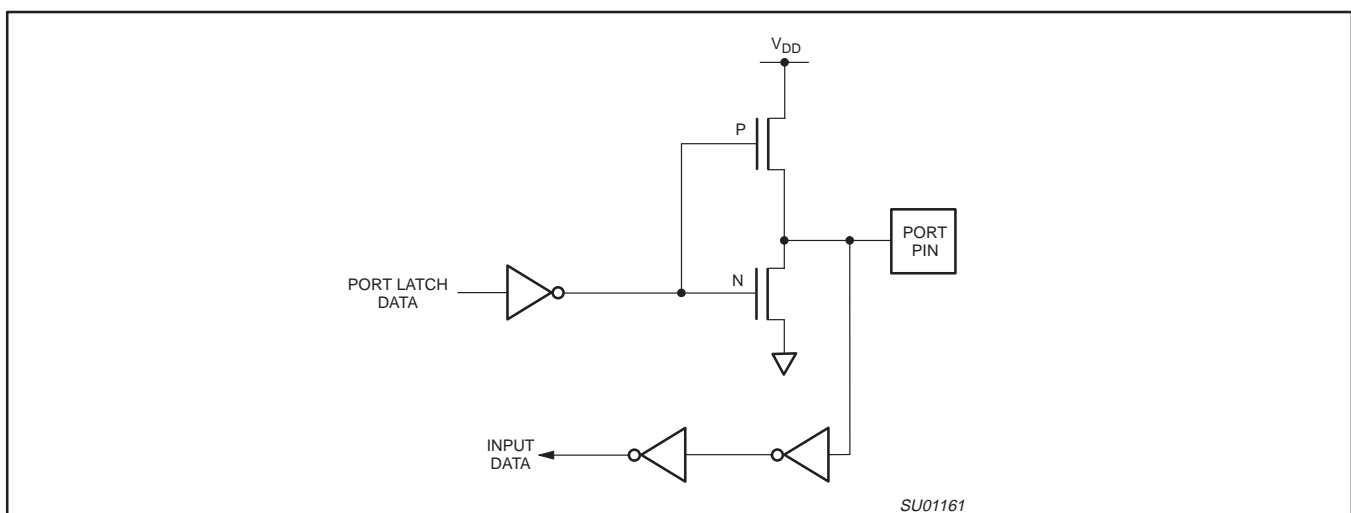
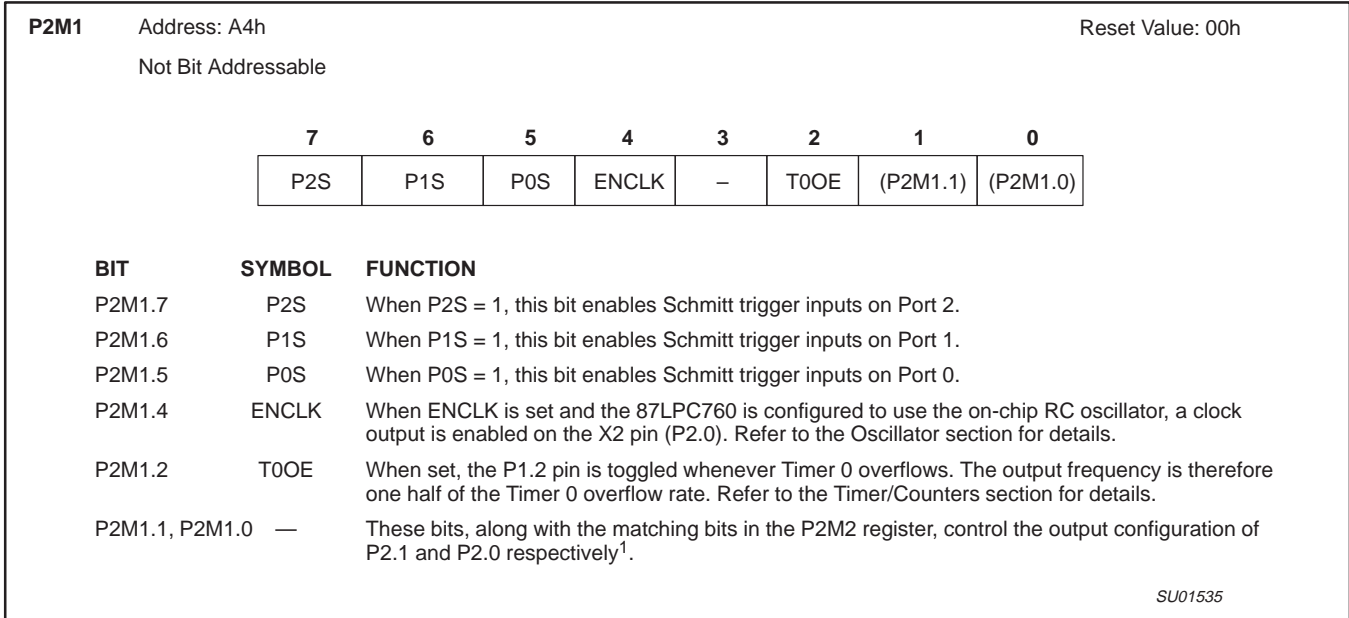

Figure 5. Push-Pull Output

Low power, low price, low pin count (14 pin) microcontroller with 1 kbyte OTP

P87LPC759



1. See Table 2, Port Output Configuration Settings.

**Figure 6. Port 2 Mode Register 1 (P2M1)**

**Keyboard Interrupt (KBI)**

The Keyboard Interrupt function is intended primarily to allow a single interrupt to be generated when any key is pressed on a keyboard or keypad connected to specific pins of the P87LPC759, as shown in Figure 7. This interrupt may be used to wake up the CPU from Idle or Power Down modes. This feature is particularly useful in handheld, battery powered systems that need to carefully manage power consumption yet also need to be convenient to use.

The P87LPC759 allows any pin of port 0 to be enabled to cause this interrupt. Port pins are enabled by the setting of bits in the KBI register, as shown in Figure 8. The Keyboard Interrupt Flag (KBF) in the AUXR1 register is set when any enabled pin is pulled low while the KBI interrupt function is active. An interrupt will generated if it has been enabled. Note that the KBF bit must be cleared by software.

Due to human time scales and the mechanical delay associated with keyswitch closures, the KBI feature will typically allow the interrupt service routine to poll port 0 in order to determine which key was pressed, even if the processor has to wake up from Power Down mode. Refer to the section on Power Reduction Modes for details.

Low power, low price, low pin count (14 pin)  
microcontroller with 1 kbyte OTP

P87LPC759

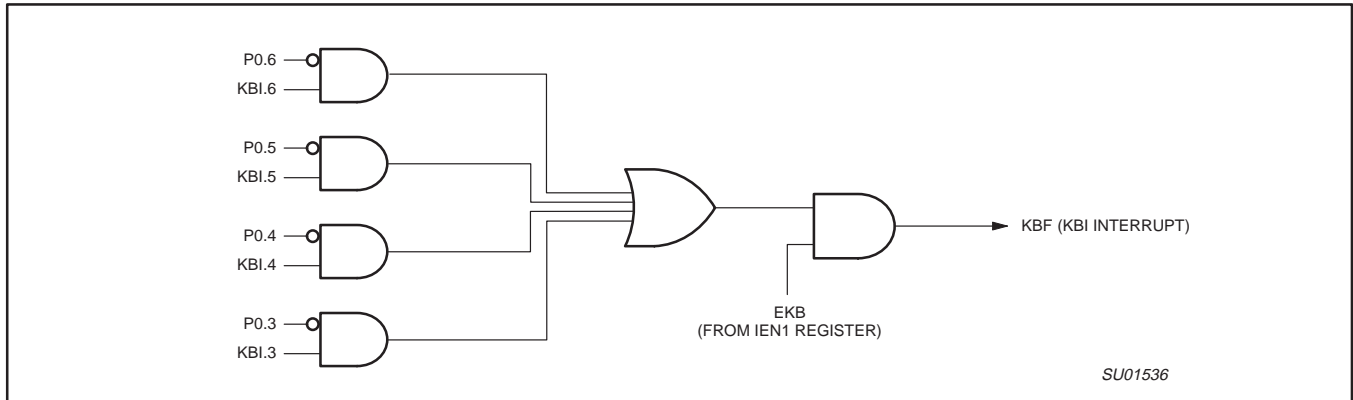

Figure 7. Keyboard Interrupt

<b>KBI</b>	Address: 86h	Reset Value: 00h						
	Not Bit Addressable							
	7	6	5	4	3	2	1	0
	-	KBI.6	KBI.5	KBI.4	KBI.3	-	-	-
<b>BIT</b>	<b>SYMBOL</b>	<b>FUNCTION</b>						
KBI.6	KBI.6	When set, enables P0.6 as a cause of a Keyboard Interrupt.						
KBI.5	KBI.5	When set, enables P0.5 as a cause of a Keyboard Interrupt.						
KBI.4	KBI.4	When set, enables P0.4 as a cause of a Keyboard Interrupt.						
KBI.3	KBI.3	When set, enables P0.3 as a cause of a Keyboard Interrupt.						
<p>Note: the Keyboard Interrupt must be enabled in order for the settings of the KBI register to be effective. The interrupt flag (KBF) is located at bit 7 of AUXR1.</p>								

SU01537

Figure 8. Keyboard Interrupt Register (KBI)

# Low power, low price, low pin count (14 pin) microcontroller with 1 kbyte OTP

## P87LPC759

### Oscillator

The P87LPC759 provides several user selectable oscillator options, allowing optimization for a range of needs from high precision to lowest possible cost. These are configured when the EPROM is programmed. Basic oscillator types that are supported include: low, medium, and high speed crystals, covering a range from 20 kHz to 20 MHz; ceramic resonators; and on-chip RC oscillator.

### Low Frequency Oscillator Option

This option supports an external crystal in the range of 20 kHz to 100 kHz.

Table 3 shows capacitor values that may be used with a quartz crystal in this mode.

**Table 3. Recommended oscillator capacitors for use with the low frequency oscillator option**

Oscillator Frequency	V <sub>DD</sub> = 2.7 to 4.5 V			V <sub>DD</sub> = 4.5 to 6.0 V		
	Lower Limit	Optimal Value	Upper Limit	Lower Limit	Optimal Value	Upper Limit
20 kHz	15 pF	15 pF	33 pF	33 pF	33 pF	47 pF
32 kHz	15 pF	15 pF	33 pF	33 pF	33 pF	47 pF
100 kHz	15 pF	15 pF	33 pF	15 pF	15 pF	33 pF

### Medium Frequency Oscillator Option

This option supports an external crystal in the range of 100 kHz to 4 MHz. Ceramic resonators are also supported in this configuration.

Table 4 shows capacitor values that may be used with a quartz crystal in this mode.

**Table 4. Recommended oscillator capacitors for use with the medium frequency oscillator option**

Oscillator Frequency	V <sub>DD</sub> = 2.7 to 4.5 V		
	Lower Limit	Optimal Value	Upper Limit
100 kHz	33 pF	33 pF	47 pF
1 MHz	15 pF	15 pF	33 pF
4 MHz	15 pF	15 pF	33 pF

### High Frequency Oscillator Option

This option supports an external crystal in the range of 4 to 20 MHz. Ceramic resonators are also supported in this configuration.

Table 5 shows capacitor values that may be used with a quartz crystal in this mode.

**Table 5. Recommended oscillator capacitors for use with the high frequency oscillator option**

Oscillator Frequency	V <sub>DD</sub> = 2.7 to 4.5 V			V <sub>DD</sub> = 4.5 to 6.0 V		
	Lower Limit	Optimal Value	Upper Limit	Lower Limit	Optimal Value	Upper Limit
4 MHz	15 pF	33 pF	47 pF	15 pF	33 pF	68 pF
8 MHz	15 pF	15 pF	33 pF	15 pF	33 pF	47 pF
16 MHz	–	–	–	15 pF	15 pF	33 pF
20 MHz	–	–	–	15 pF	15 pF	33 pF

### On-Chip RC Oscillator Option

The on-chip RC oscillator option has a typical frequency of 6 MHz and can be divided down for slower operation through the use of the DIVM register. For on-chip oscillator tolerance see AC Electrical Characteristics table. A clock output on the X2/P2.0 pin may be enabled when the on-chip RC oscillator is used.

### External Clock Input Option

In this configuration, the processor clock is input from an external source driving the X1/P2.1 pin. The rate may be from 0 Hz up to 20 MHz when V<sub>DD</sub> is above 4.5 V and up to 10 MHz when V<sub>DD</sub> is below 4.5 V. When the external clock input mode is used, the X2/P2.0 pin may be used as a standard port pin. A clock output on

the X2/P2.0 pin may be enabled when the external clock input is used.

### Clock Output

The P87LPC759 supports a clock output function when either the on-chip RC oscillator or external clock input options are selected. This allows external devices to synchronize to the P87LPC759. When enabled, via the ENCLK bit in the P2M1 register, the clock output appears on the X2/CLKOUT pin whenever the on-chip oscillator is running, including in Idle mode. The frequency of the clock output is 1/6 of the CPU clock rate. If the clock output is not needed in Idle mode, it may be turned off prior to entering Idle, saving additional power. The clock output may also be enabled when the external clock input option is selected.



Low power, low price, low pin count (14 pin)  
microcontroller with 1 kbyte OTP

P87LPC759

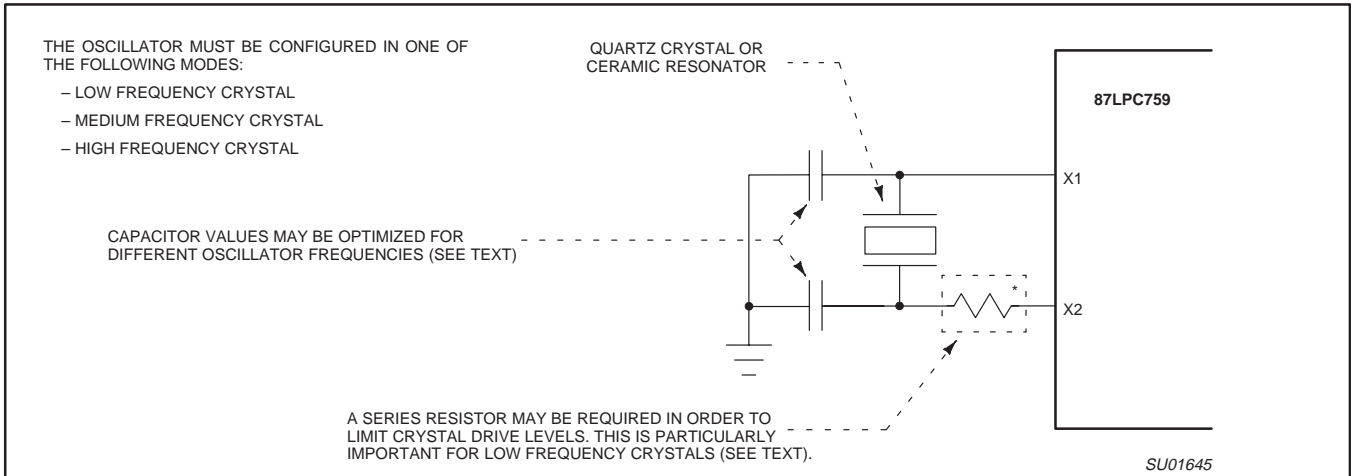

Figure 9. Using the Crystal Oscillator

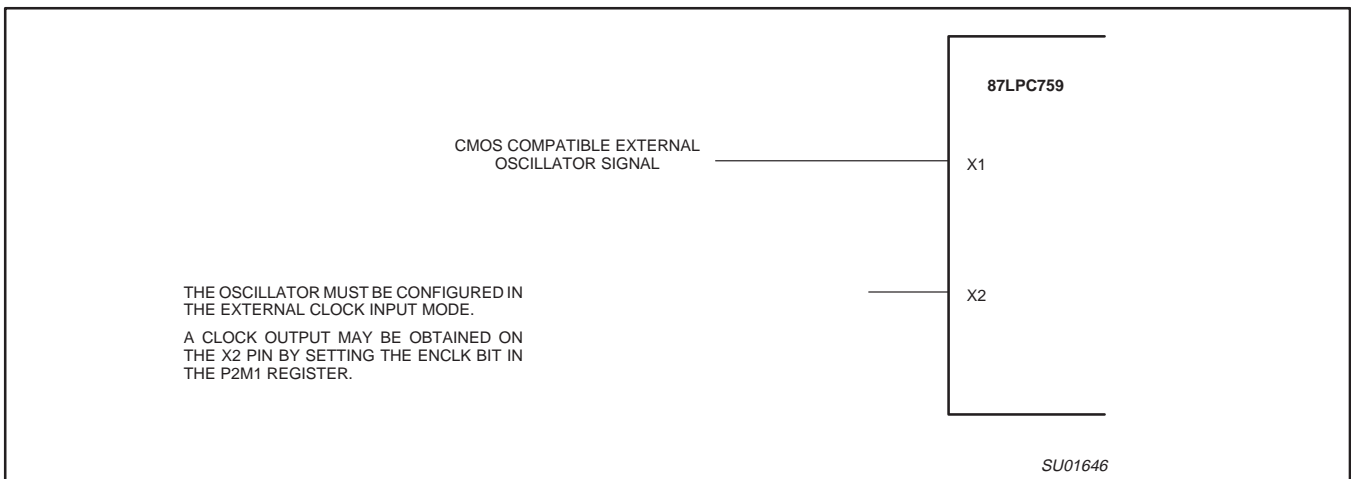

Figure 10. Using an External Clock Input

# Low power, low price, low pin count (14 pin) microcontroller with 1 kbyte OTP

## P87LPC759

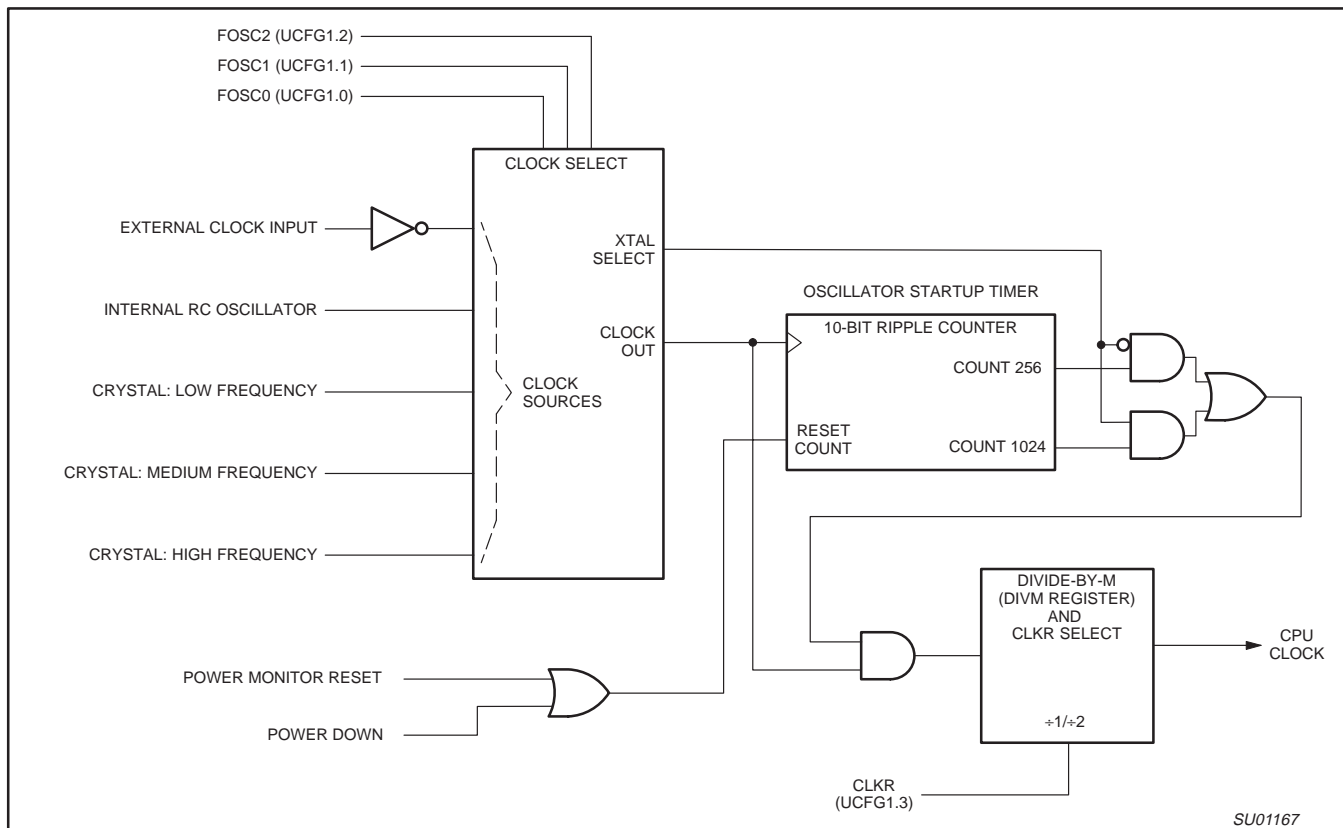

Figure 11. Block Diagram of Oscillator Control

### CPU Clock Modification: CLKR and DIVM

For backward compatibility, the CLKR configuration bit allows setting the P87LPC759 instruction and peripheral timing to match standard 80C51 timing by dividing the CPU clock by two. Default timing for the P87LPC759 is 6 CPU clocks per machine cycle while standard 80C51 timing is 12 clocks per machine cycle. This division also applies to peripheral timing, allowing 80C51 code that is oscillator frequency and/or timer rate dependent. The CLKR bit is located in the EPROM configuration register UCFG1, described under EPROM Characteristics

In addition to this, the CPU clock may be divided down from the oscillator rate by a programmable divider, under program control. This function is controlled by the DIVM register. If the DIVM register is set to zero (the default value), the CPU will be clocked by either the unmodified oscillator rate, or that rate divided by two, as determined by the previously described CLKR function.

When the DIVM register is set to some value N (between 1 and 255), the CPU clock is divided by  $2 * (N + 1)$ . Clock division values from 4 through 512 are thus possible. This feature makes it possible to temporarily run the CPU at a lower rate, reducing power consumption, in a manner similar to Idle mode. By dividing the clock, the CPU can retain the ability to respond to events other than those that can cause interrupts (i.e. events that allow exiting the Idle mode) by executing its normal program at a lower rate. This can allow bypassing the oscillator startup time in cases where Power Down mode would otherwise be used. The value of DIVM may be changed by the program at any time without interrupting code execution.

### Power Monitoring Functions

The P87LPC759 incorporates power monitoring functions designed to prevent incorrect operation during initial power up and power loss or reduction during operation. This is accomplished with two hardware functions: Power-On Detect and Brownout Detect.

#### Brownout Detection

The Brownout Detect function allows preventing the processor from failing in an unpredictable manner if the power supply voltage drops below a certain level. The default operation is for a brownout detection to cause a processor reset, however it may alternatively be configured to generate an interrupt by setting the BOI bit in the AUXR1 register (AUXR1.5).

The P87LPC759 allows selection of two Brownout levels: 2.5 V or 3.8 V. When  $V_{DD}$  drops below the selected voltage, the brownout detector triggers and remains active until  $V_{DD}$  returns to a level above the Brownout Detect voltage. When Brownout Detect causes a processor reset, that reset remains active as long as  $V_{DD}$  remains below the Brownout Detect voltage. When Brownout Detect generates an interrupt, that interrupt occurs once as  $V_{DD}$  crosses from above to below the Brownout Detect voltage. For the interrupt to be processed, the interrupt system and the BOI interrupt must both be enabled (via the EA and EBO bits in IEN0).

When Brownout Detect is activated, the BOF flag in the PCON register is set so that the cause of processor reset may be determined by software. This flag will remain set until cleared by software.

## Low power, low price, low pin count (14 pin) microcontroller with 1 kbyte OTP

# P87LPC759

For correct activation of Brownout Detect, the  $V_{DD}$  fall time must be no faster than 50 mV/ $\mu$ s. When  $V_{DD}$  is restored, it should not rise faster than 2 mV/ $\mu$ s in order to insure a proper reset.

The brownout voltage (2.5 V or 3.8 V) is selected via the BOV bit in the EPROM configuration register UCFG1. When unprogrammed (BOV = 1), the brownout detect voltage is 2.5 V. When programmed (BOV = 0), the brownout detect voltage is 3.8 V.

If the Brownout Detect function is not required in an application, it may be disabled, thus saving power. Brownout Detect is disabled by setting the control bit BOD in the AUXR1 register (AUXR1.6).

### Power On Detection

The Power On Detect has a function similar to the Brownout Detect, but is designed to work as power comes up initially, before the power supply voltage reaches a level where Brownout Detect can work. When this feature is activated, the POF flag in the PCON register is set to indicate an initial power up condition. The POF flag will remain set until cleared by software.

### Power Reduction Modes

The P87LPC759 supports Idle and Power Down modes of power reduction.

#### Idle Mode

The Idle mode leaves peripherals running in order to allow them to activate the processor when an interrupt is generated. Any enabled interrupt source or Reset may terminate Idle mode. Idle mode is entered by setting the IDL bit in the PCON register (see Figure 12).

#### Power Down Mode

The Power Down mode stops the oscillator in order to absolutely minimize power consumption. Power Down mode is entered by setting the PD bit in the PCON register (see Figure 12).

The processor can be made to exit Power Down mode via Reset or one of the interrupt sources shown in Table 3. This will occur if the interrupt is enabled and its priority is higher than any interrupt currently in progress.

In Power Down mode, the power supply voltage may be reduced to the RAM keep-alive voltage  $V_{RAM}$ . This retains the RAM contents at the point where Power Down mode was entered. SFR contents are not guaranteed after  $V_{DD}$  has been lowered to  $V_{RAM}$ , therefore it is recommended to wake up the processor via Reset in this case.  $V_{DD}$  must be raised to within the operating range before the Power Down mode is exited. Since the watchdog timer has a separate oscillator, it may reset the processor upon overflow if it is running during Power Down.

Note that if the Brownout Detect reset is enabled, the processor will be put into reset as soon as  $V_{DD}$  drops below the brownout voltage. If Brownout Detect is configured as an interrupt and is enabled, it will wake up the processor from Power Down mode when  $V_{DD}$  drops below the brownout voltage.

When the processor wakes up from Power Down mode, it will start the oscillator immediately and begin execution when the oscillator is stable. Oscillator stability is determined by counting 1024 CPU clocks after start-up when one of the crystal oscillator configurations is used, or 256 clocks after start-up for the internal RC or external clock input configurations.

Some chip functions continue to operate and draw power during Power Down mode, increasing the total power used during Power Down. These include the Brownout Detect and Watchdog Timer.

PCON		Address: 87h		Reset Value:		• 30h for a Power On reset • 20h for a Brownout reset • 00h for other reset sources			
		Not Bit Addressable							
		7	6	5	4	3	2	1	0
		–	–	BOF	POF	GF1	GF0	PD	IDL
BIT	SYMBOL	FUNCTION							
PCON.7	–	Reserved							
PCON.6	–	Reserved							
PCON.5	BOF	Brown Out Flag. Set automatically when a brownout reset or interrupt has occurred. Also set at power on. Cleared by software. Refer to the Power Monitoring Functions section for additional information.							
PCON.4	POF	Power On Flag. Set automatically when a power-on reset has occurred. Cleared by software. Refer to the Power Monitoring Functions section for additional information.							
PCON.3	GF1	General purpose flag 1. May be read or written by user software, but has no effect on operation.							
PCON.2	GF0	General purpose flag 0. May be read or written by user software, but has no effect on operation.							
PCON.1	PD	Power Down control bit. Setting this bit activates Power Down mode operation. Cleared when the Power Down mode is terminated (see text).							
PCON.0	IDL	Idle mode control bit. Setting this bit activates Idle mode operation. Cleared when the Idle mode is terminated (see text).							

SU01647

Figure 12. Power Control Register (PCON)

---

**Low power, low price, low pin count (14 pin)  
microcontroller with 1 kbyte OTP**

---

**P87LPC759****Table 6. Sources of Wakeup from Power Down Mode**

<b>Wakeup Source</b>	<b>Conditions</b>
External Interrupt 0	The interrupt must be enabled.
Keyboard Interrupt	The keyboard interrupt feature must be enabled and properly set up. The corresponding interrupt must be enabled.
Watchdog Timer Reset	The watchdog timer must be enabled via the WDTE bit in the UCFG1 EPROM configuration byte.
Watchdog Timer Interrupt	The WDTE bit in the UCFG1 EPROM configuration byte must not be set. The corresponding interrupt must be enabled.
Brownout Detect Reset	The BOD bit in AUXR1 must not be set (brownout detect not disabled). The BOI bit in AUXR1 must not be set (brownout interrupt disabled).
Brownout Detect Interrupt	The BOD bit in AUXR1 must not be set (brownout detect not disabled). The BOI bit in AUXR1 must be set (brownout interrupt enabled). The corresponding interrupt must be enabled.
Reset Input	The external reset input must be enabled.

# Low power, low price, low pin count (14 pin) microcontroller with 1 kbyte OTP

## P87LPC759

### Low Voltage EPROM Operation

The EPROM array contains some analog circuits that are not required when  $V_{DD}$  is less than 4 V, but are required for a  $V_{DD}$  greater than 4 V. The LPEP bit (AUXR.4), when set by software, will power down these analog circuits resulting in a reduced supply current. LPEP is cleared only by power-on reset, so it may be set ONLY for applications that always operate with  $V_{DD}$  less than 4 V.

### Reset

The P87LPC759 has an integrated power-on reset circuit which always provides a reset when power is initially applied to the device. It is recommended to use the internal reset whenever possible to

save external components and to be able to use pin P1.5 as a general-purpose input pin.

The P87LPC759 can additionally be configured to use P1.5 as an external active-low reset pin  $\overline{RST}$  by programming the RPD bit in the User Configuration Register UCFG1 to 0. The internal reset is still active on power-up of the device. While the signal on the  $\overline{RST}$  pin is low, the P87LPC759 is held in reset until the signal goes high.

The watchdog timer on the P87LPC759 can act as an oscillator fail detect because it uses an independent, fully on-chip oscillator.

UCFG1 is described in the System Configuration Bytes section of this datasheet.

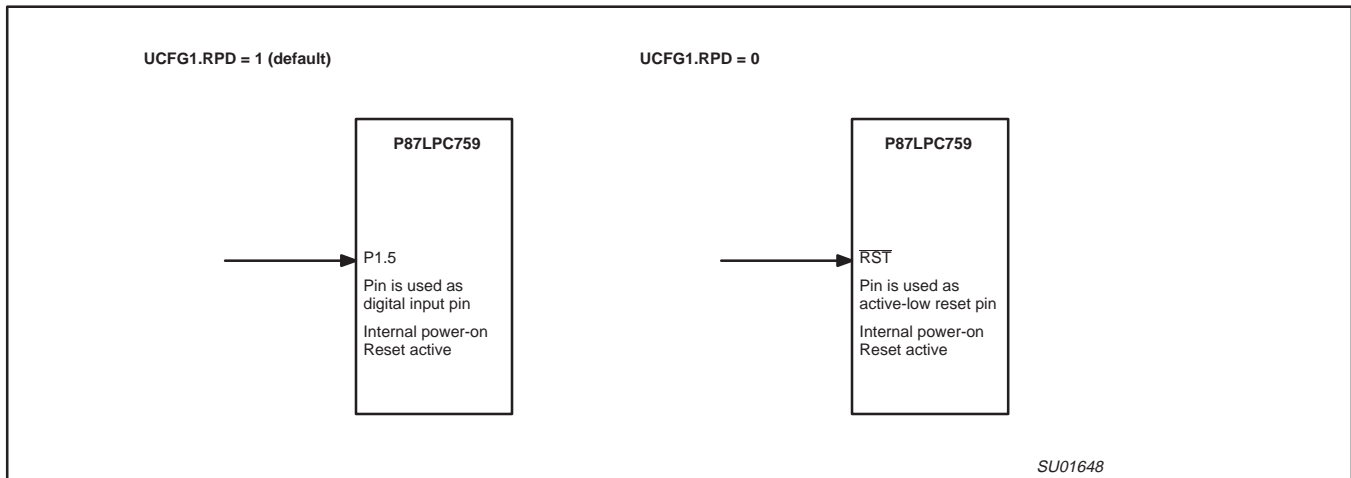

Figure 13. Using pin P1.5 as general purpose input pin or as low-active reset pin

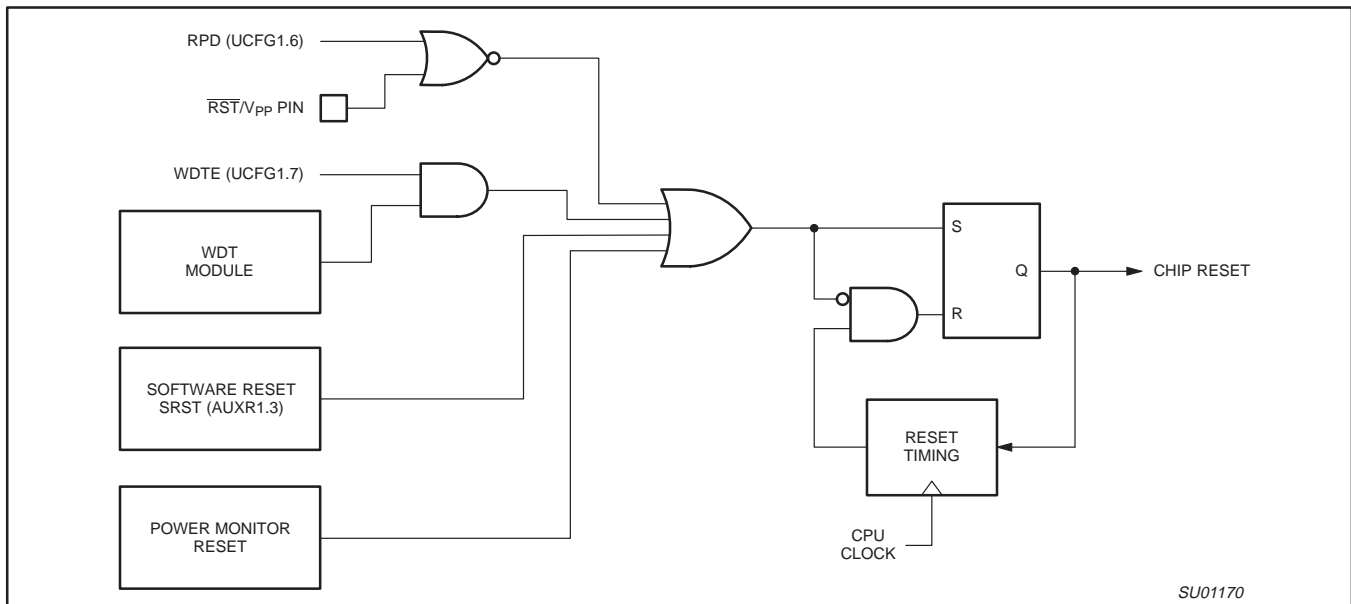

Figure 14. Block Diagram Showing Reset Sources



# Low power, low price, low pin count (14 pin) microcontroller with 1 kbyte OTP

## P87LPC759

### Mode 0

Putting either Timer into Mode 0 makes it look like an 8048 Timer, which is an 8-bit Counter with a divide-by-32 prescaler. Figures 17 and 18 show Mode 0 operation.

In this mode, the Timer register is configured as a 13-bit register. As the count rolls over from all 1s to all 0s, it sets the Timer interrupt flag TF<sub>n</sub>. The count input is enabled to Timer 0 when TR0 = 1 and either GATE = 0 or INT0 = 1. (Setting GATE = 1 allows the Timer to be controlled by external input INT0, to facilitate pulse width

measurements). TR<sub>n</sub> is a control bit in the Special Function Register TCON (Figure 16). The GATE bit is in the TMOD register (TMOD.3).

The 13-bit register consists of all 8 bits of TH<sub>n</sub> and the lower 5 bits of TL<sub>n</sub>. The upper 3 bits of TL<sub>n</sub> are indeterminate and should be ignored. Setting the run flag (TR<sub>n</sub>) does not clear the registers.

Mode 0 operation is slightly different for Timer 0 and Timer 1. See Figures 17 and 18.

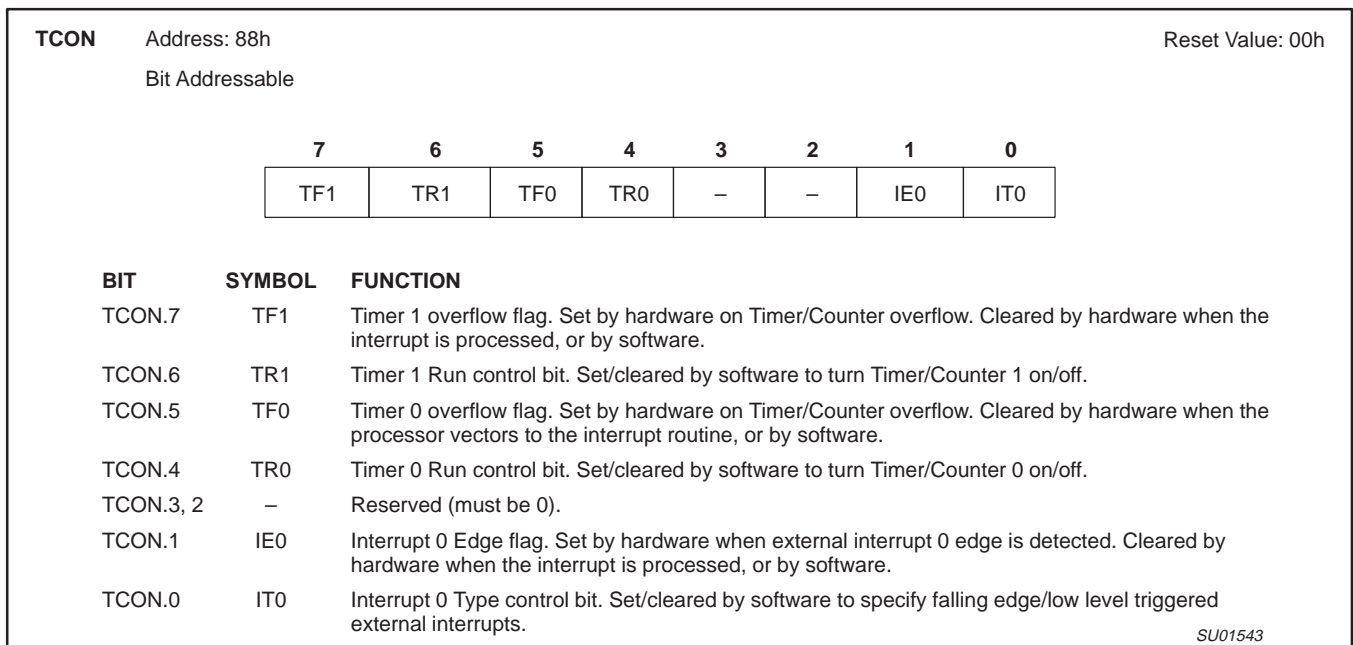

Figure 16. Timer/Counter Control Register (TCON)

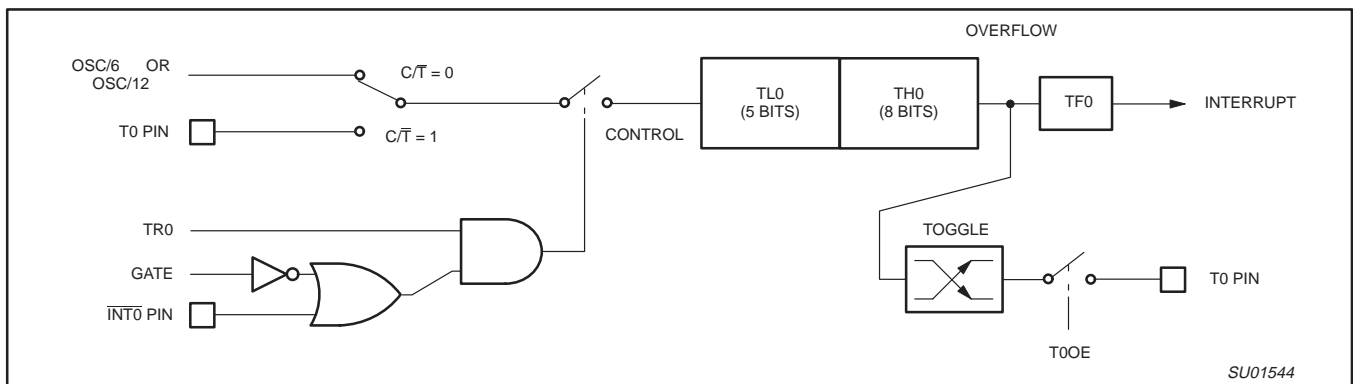

Figure 17. Timer/Counter 0 in Mode 0 (13-Bit Timer/Counter)

Low power, low price, low pin count (14 pin)  
microcontroller with 1 kbyte OTP

P87LPC759

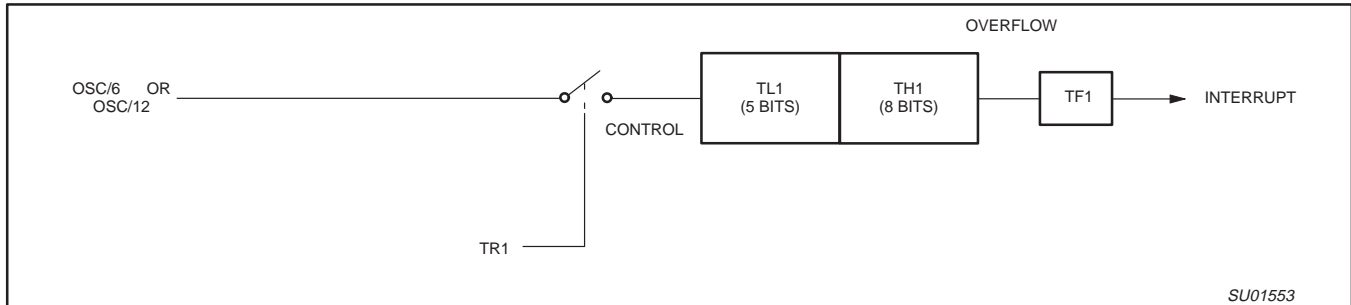

Figure 18. Timer 1 in Mode 0 (13-Bit Timer)

**Mode 1**

Mode 1 is the same as Mode 0, except that all 16 bits of the timer register (THn and TLn) are used. (See Figures 19 and 20)

**Mode 2**

Mode 2 configures the Timer register as an 8-bit Counter (TLn) with automatic reload, as shown in Figures 21 and 22. Overflow from TLn not only sets TFn, but also reloads TLn with the contents of THn, which must be preset by software. The reload leaves THn unchanged. Mode 2 operation is slightly different for Timer 0 and Timer 1 (see Figures 21 and 22).

**Mode 3**

When Timer 1 is in Mode 3 it is stopped. The effect is the same as setting TR1 = 0.

Timer 0 in Mode 3 establishes TL0 and TH0 as two separate 8-bit counters. The logic for Mode 3 on Timer 0 is shown in Figure 23. TL0 uses the Timer 0 control bits: C/T, GATE, TR0, and TF0 as well as the INT0 pin. TH0 is locked into a timer function (counting machine cycles) and takes over the use of TR1 and TF1 from Timer 1. Thus, TH0 now controls the "Timer 1" interrupt.

Mode 3 is provided for applications that require an extra 8-bit timer. With Timer 0 in Mode 3, an P87LPC759 can look like it has three Timer/Counters. When Timer 0 is in Mode 3, Timer 1 can be turned on and off by switching it into and out of its own Mode 3. It can still be used by the serial port as a baud rate generator, or in any application not requiring an interrupt.

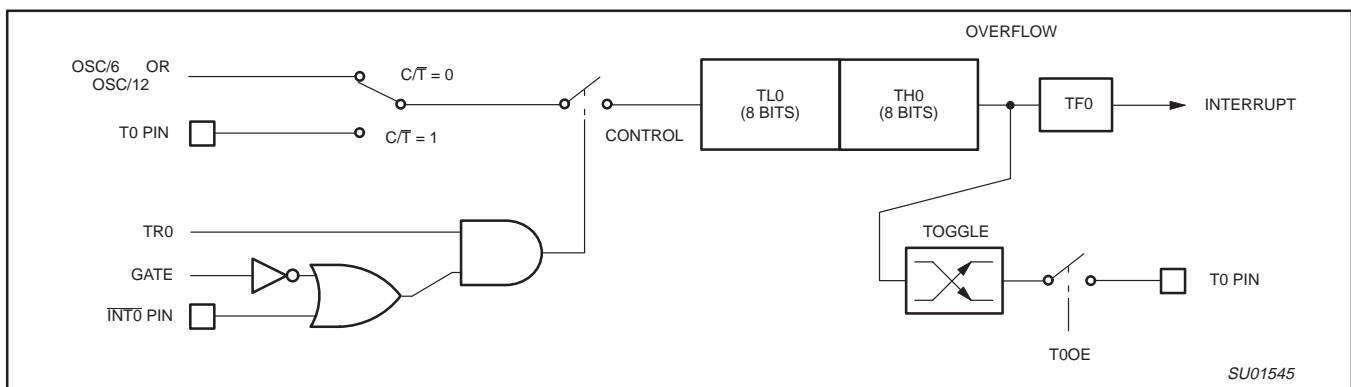

Figure 19. Timer/Counter 0 in Mode 1 (16-Bit Timer/Counter)

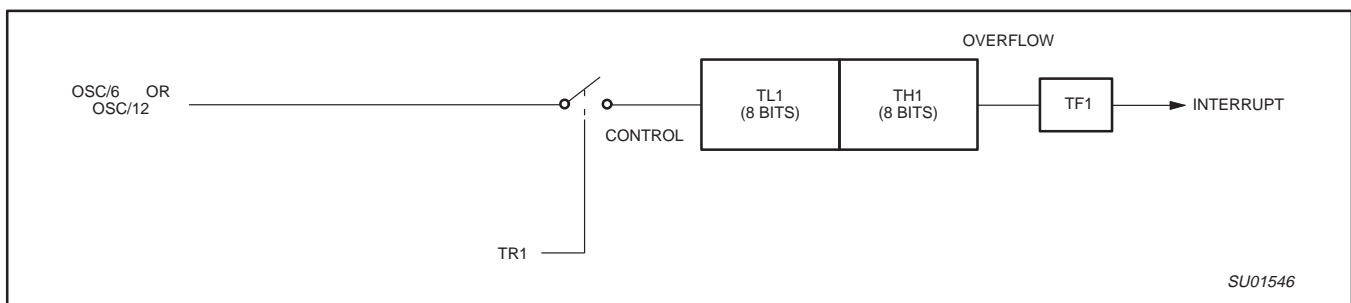

Figure 20. Timer 1 in Mode 1 (16-Bit Timer)



Low power, low price, low pin count (14 pin)  
microcontroller with 1 kbyte OTP

P87LPC759

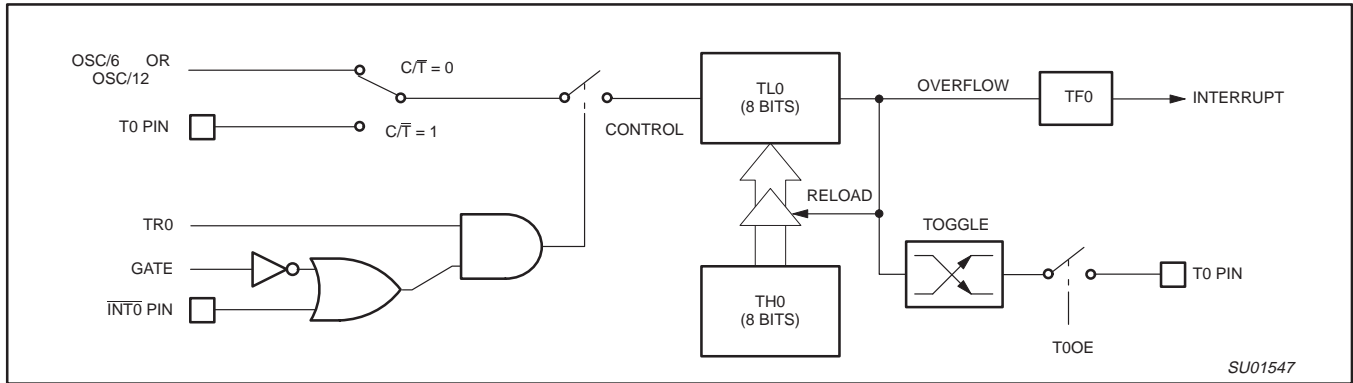

Figure 21. Timer/Counter 0 in Mode 2 (8-Bit Auto-Reload)

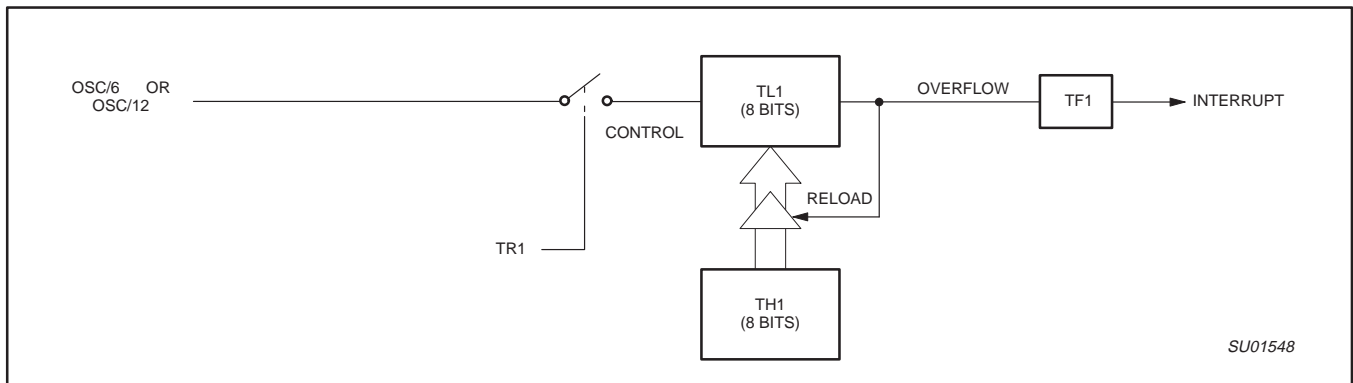

Figure 22. Timer 1 in Mode 2 (8-Bit Auto-Reload)

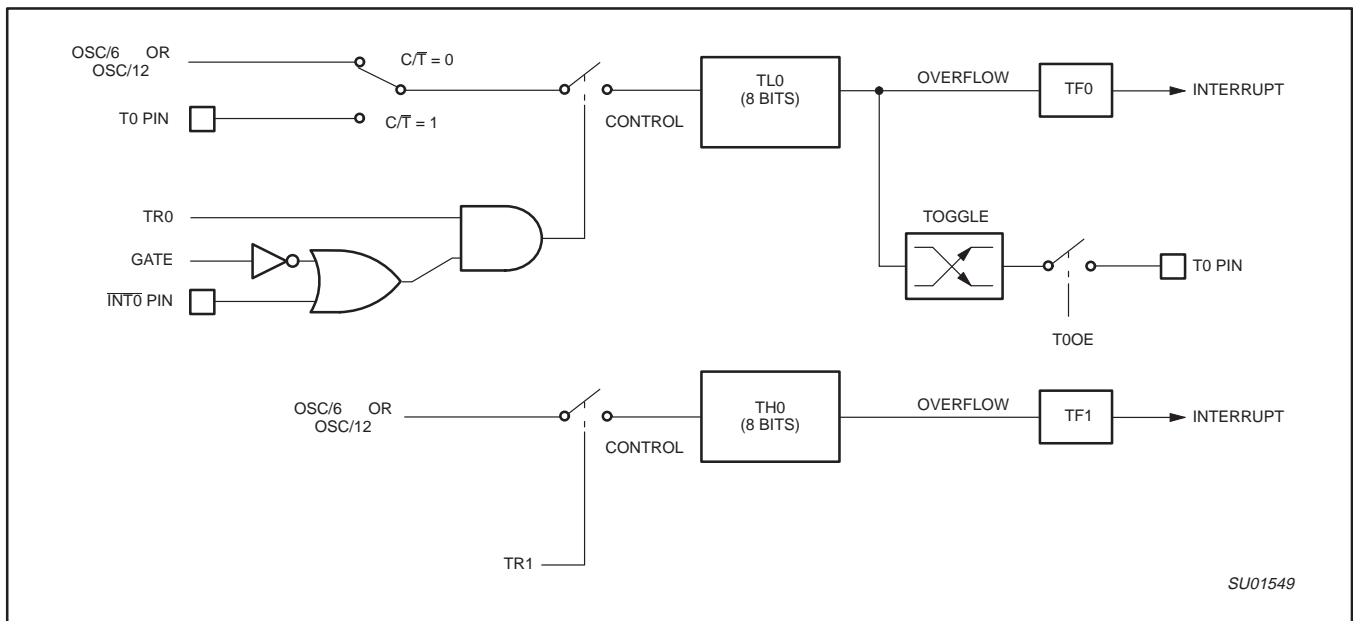

Figure 23. Timer/Counter 0 Mode 3 (Two 8-Bit Timer/Counters)

# Low power, low price, low pin count (14 pin) microcontroller with 1 kbyte OTP

## P87LPC759

### Timer Overflow Toggle Output

Timer 0 can be configured to automatically toggle a port output whenever a timer overflow occurs. The same device pins that is used for the T0 count inputs are also used for the timer toggle outputs. This function is enabled by control bit T0OE in the P2M1 register. The port outputs will be a logic 1 prior to the first timer overflow when this mode is turned on.

### Watchdog Timer

When enabled via the WDTE configuration bit, the watchdog timer is operated from an independent, fully on-chip oscillator in order to provide the greatest possible dependability. When the watchdog feature is enabled, the timer must be fed regularly by software in order to prevent it from resetting the CPU, and it cannot be turned off. When disabled as a watchdog timer (via the WDTE bit in the UCFG1 configuration register), it may be used as an interval timer and may generate an interrupt. The watchdog timer is shown in Figure 24.

The watchdog timeout time is selectable from one of eight values, nominal times range from 25 milliseconds to 3.2 seconds. The frequency tolerance of the independent watchdog RC oscillator is  $\pm 37\%$ . When the watchdog function is enabled, the WDCON register may be written once during chip initialization in order to set the watchdog timeout time. The recommended method of initializing the WDCON register is to first feed the watchdog, then write to WDCON to configure the WDS2–0 bits. Using this method, the watchdog initialization may be done any time within 10 milliseconds after startup without a watchdog overflow occurring before the initialization can be completed.

Since the watchdog timer oscillator is fully on-chip and independent of any external oscillator circuit used by the CPU, it intrinsically serves as an oscillator fail detection function. If the watchdog feature is enabled and the CPU oscillator fails for any reason, the watchdog timer will time out and reset the CPU.

When the watchdog function is enabled, the timer is deactivated temporarily when a chip reset occurs from another source, such as a power on reset, brownout reset, or external reset.

### Watchdog Feed Sequence

If the watchdog timer is running, it must be fed before it times out in order to prevent a chip reset from occurring. The watchdog feed sequence consists of first writing the value 1Eh, then the value E1h to the WDRST register. An example of a watchdog feed sequence is shown below.

```
WDFeed:
    mov  WDRST,#1eh ; First part of watchdog feed
    sequence.
    mov  WDRST,#0e1h ; Second part of watchdog feed
    sequence.
```

The two writes to WDRST do not have to occur in consecutive instructions. An incorrect watchdog feed sequence does not cause any immediate response from the watchdog timer, which will still time out at the originally scheduled time if a correct feed sequence does not occur prior to that time.

After a chip reset, the user program has a limited time in which to either feed the watchdog timer or change the timeout period. When a low CPU clock frequency is used in the application, the number of instructions that can be executed before the watchdog overflows may be quite small.

### Watchdog Reset

If a watchdog reset occurs, the internal reset is active for approximately one microsecond. If the CPU clock was still running, code execution will begin immediately after that. If the processor was in Power Down mode, the watchdog reset will start the oscillator and code execution will resume after the oscillator is stable.

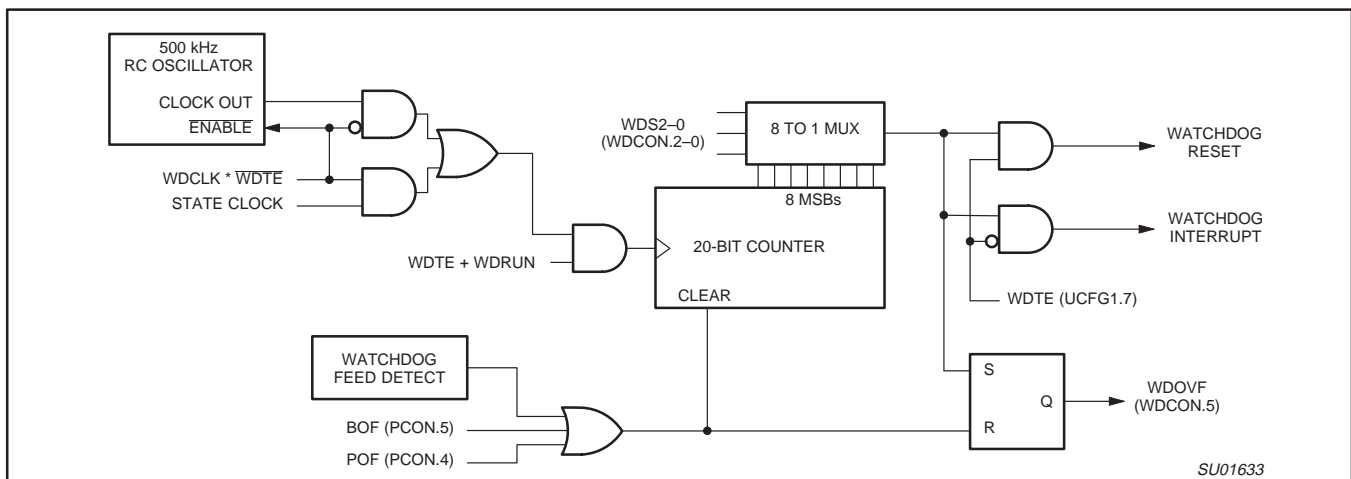

Figure 24. Block Diagram of the Watchdog Timer

SU01633

Low power, low price, low pin count (14 pin) microcontroller with 1 kbyte OTP

P87LPC759

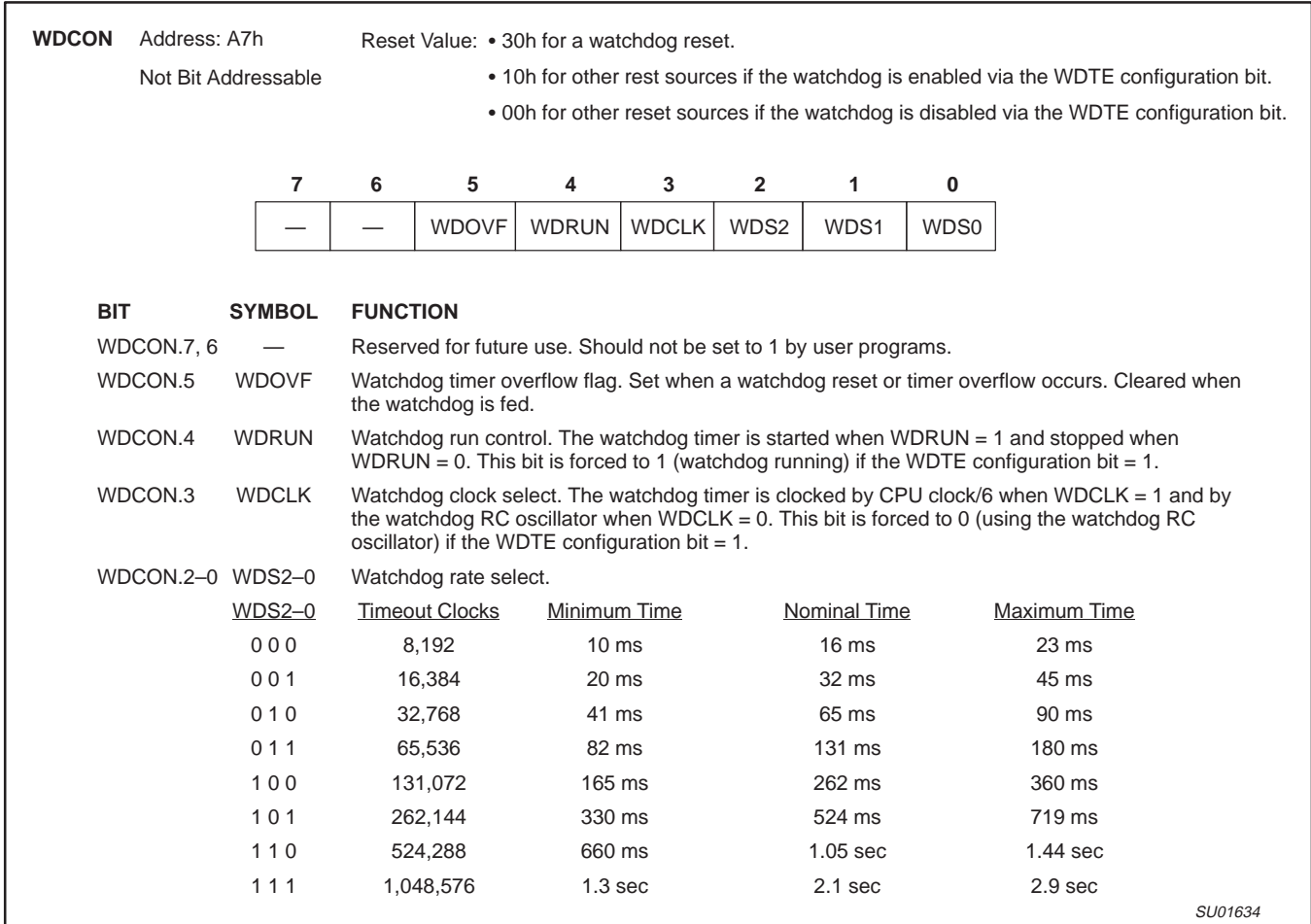

Figure 25. Watchdog Timer Control Register (WDCON)

# Low power, low price, low pin count (14 pin) microcontroller with 1 kbyte OTP

## P87LPC759

### Additional Features

The AUXR1 register contains several special purpose control bits that relate to several chip features. AUXR1 is described in Figure 26.

### Software Reset

The SRST bit in AUXR1 allows software the opportunity to reset the processor completely, as if an external reset or watchdog reset had occurred. If a value is written to AUXR1 that contains a 1 at bit position 3, all SFRs will be initialized and execution will resume at program address 0000. Care should be taken when writing to AUXR1 to avoid accidental software resets.

### Dual Data Pointers

The dual Data Pointer (DPTR) adds to the ways in which the processor can specify the address used with certain instructions. The DPS bit in the AUXR1 register selects one of the two Data Pointers. The DPTR that is not currently selected is not accessible to software unless the DPS bit is toggled.

Specific instructions affected by the Data Pointer selection are:

- INC DPTR Increments the Data Pointer by 1.
- JMP @A+DPTR Jump indirect relative to DPTR value.

- MOV DPTR, #data16 Load the Data Pointer with a 16-bit constant.
- MOVC A, @A+DPTR Move code byte relative to DPTR to the accumulator.
- MOVX A, @DPTR Move data byte the accumulator to data memory relative to DPTR.
- MOVX @DPTR, A Move data byte from data memory relative to DPTR to the accumulator.

Also, any instruction that reads or manipulates the DPH and DPL registers (the upper and lower bytes of the current DPTR) will be affected by the setting of DPS. The MOVX instructions have limited application for the P87LPC759 since the part does not have an external data bus. However, they may be used to access EPROM configuration information (see EPROM Characteristics section).

Bit 2 of AUXR1 is permanently wired as a logic 0. This is so that the DPS bit may be toggled (thereby switching Data Pointers) simply by incrementing the AUXR1 register, without the possibility of inadvertently altering other bits in the register.

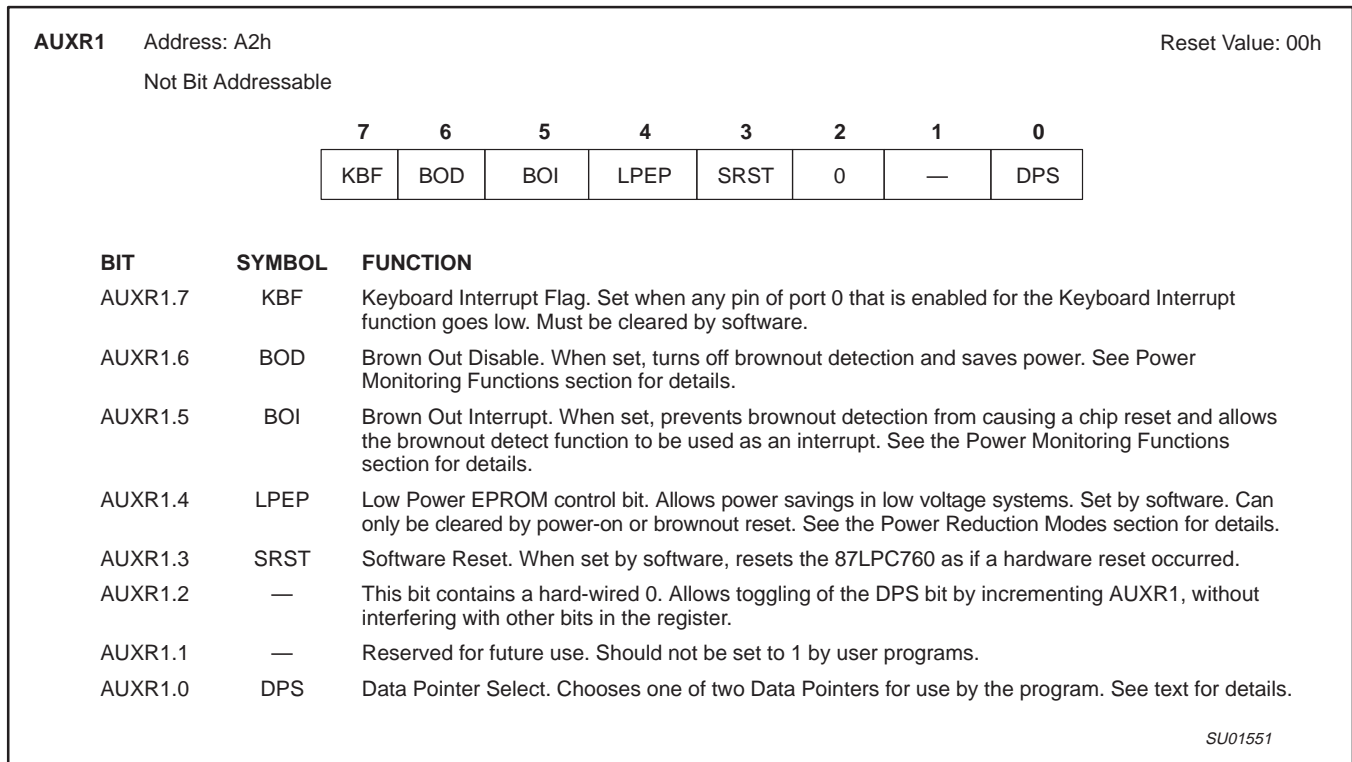

Figure 26. AUXR1 Register

# Low power, low price, low pin count (14 pin) microcontroller with 1 kbyte OTP

## P87LPC759

### EPROM Characteristics

Programming of the EPROM on the P87LPC759 is accomplished with a serial programming method. Commands, addresses, and data are transmitted to and from the device on two pins after programming mode is entered. Serial programming allows easy implementation of On-Board Programming of the P87LPC759 in an application board. Details of On-Board Programming can be found in application note AN466.

The P87LPC759 contains three signature bytes that can be read and used by an EPROM programming system to identify the device. The signature bytes designate the device as an P87LPC759 manufactured by Philips. The signature bytes may be read by the

user program at addresses FC30h, FC31h and FC60h with the MOVC instruction, using the DPTR register for addressing.

### System Configuration Bytes

A number of user configurable features of the P87LPC759 must be defined at power up and therefore cannot be set by the program after start of execution. Those features are configured through the use of two EPROM bytes that are programmed in the same manner as the EPROM program space. The contents of the two configuration bytes, UCFG1 and UCFG2, are shown in Figures 27 and 28. The values of these bytes may be read by the program through the use of the MOVX instruction at the addresses shown in the figure.

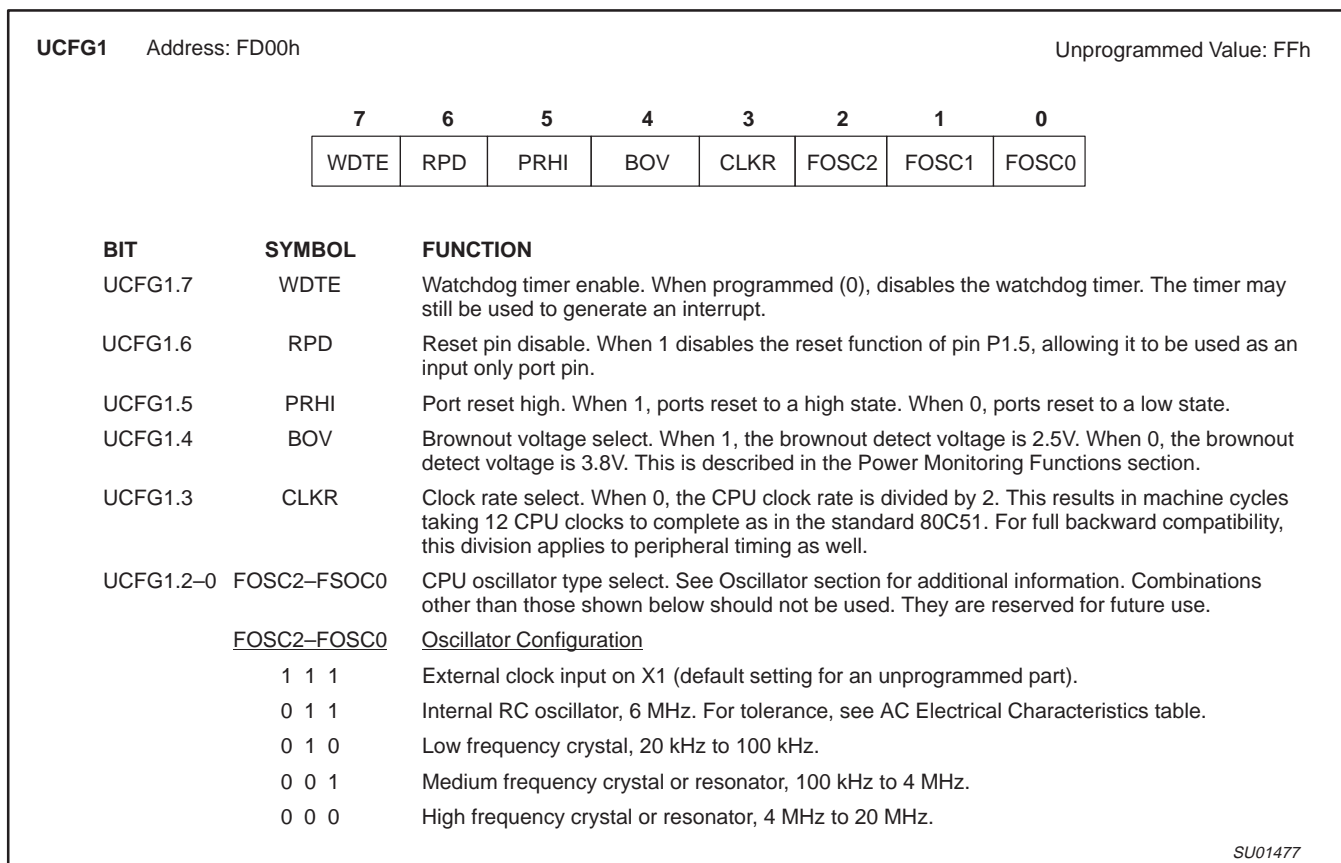

Figure 27. EPROM System Configuration Byte 1 (UCFG1)

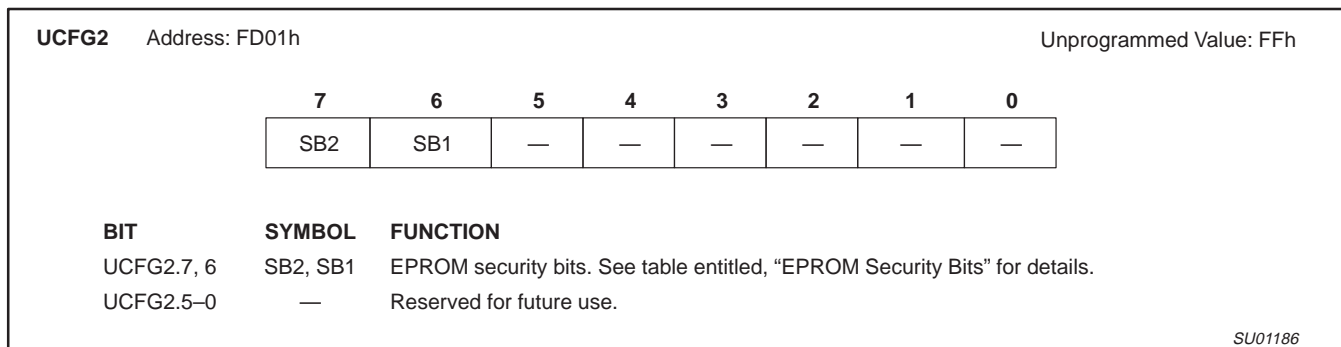

Figure 28. EPROM System Configuration Byte 2 (UCFG2)

Low power, low price, low pin count (14 pin)  
microcontroller with 1 kbyte OTP

P87LPC759

**Security Bits**

When neither of the security bits are programmed, the code in the EPROM can be verified. When only security bit 1 is programmed, all

further programming of the EPROM is disabled. At that point, only security bit 2 may still be programmed. When both security bits are programmed, EPROM verify is also disabled.

**Table 7. EPROM Security Bits**

SB2	SB1	Protection Description
1	1	Both security bits unprogrammed. No program security features enabled. EPROM is programmable and verifiable.
1	0	Only security bit 1 programmed. Further EPROM programming is disabled. Security bit 2 may still be programmed.
0	1	Only security bit 2 programmed. This combination is not supported.
0	0	Both security bits programmed. All EPROM verification and programming are disabled.

Low power, low price, low pin count (14 pin)  
microcontroller with 1 kbyte OTP

P87LPC759

**ABSOLUTE MAXIMUM RATINGS**

PARAMETER	RATING	UNIT
Operating temperature under bias	-55 to +125	°C
Storage temperature range	-65 to +150	°C
Voltage on $\overline{\text{RST}}/V_{\text{PP}}$ pin to $V_{\text{SS}}$	0 to +11.0	V
Voltage on any other pin to $V_{\text{SS}}$	-0.5 to $V_{\text{DD}}+0.5\text{V}$	V
Maximum $I_{\text{OL}}$ per I/O pin	20	mA
Power dissipation (based on package heat transfer, not device power consumption)	1.5	W

**NOTES:**

1. Stresses above those listed under Absolute Maximum Ratings may cause permanent damage to the device. This is a stress rating only and functional operation of the device at these or any conditions other than those described in the AC and DC Electrical Characteristics section of this specification are not implied.
2. This product includes circuitry specifically designed for the protection of its internal devices from the damaging effects of excessive static charge. Nonetheless, it is suggested that conventional precautions be taken to avoid applying greater than the rated maximum.
3. Parameters are valid over operating temperature range unless otherwise specified. All voltages are with respect to  $V_{\text{SS}}$  unless otherwise noted.

# Low power, low price, low pin count (14 pin) microcontroller with 1 kbyte OTP

P87LPC759

## DC ELECTRICAL CHARACTERISTICS

$V_{DD} = 2.7\text{ V}$  to  $6.0\text{ V}$  unless otherwise specified;  $T_{amb} = 0\text{ }^{\circ}\text{C}$  to  $+70\text{ }^{\circ}\text{C}$ , unless otherwise specified.

SYMBOL	PARAMETER	TEST CONDITIONS	LIMITS			UNIT
			MIN	TYP <sup>1,2</sup>	MAX	
I <sub>DD</sub>	Power supply current, operating	5.0 V, 20 MHz <sup>11</sup>	–	15	25	mA
		3.0 V, 10 MHz <sup>11</sup>	–	4	7	mA
I <sub>RC</sub>	Power supply current, operating RC Osc.	5.0 V, 6 MHz <sup>11</sup>	–	4	–	mA
		3.0 V, 6 MHz <sup>11</sup>	–	2	–	mA
I <sub>ID</sub>	Power supply current, Idle mode	5.0 V, 20 MHz <sup>11</sup>	–	6	10	mA
		3.0 V, 10 MHz <sup>11</sup>	–	2	4	mA
I <sub>PD</sub>	Power supply current, Power Down mode	5.0 V <sup>11</sup>	–	1	10	μA
		3.0 V <sup>11</sup>	–	1	5	μA
V <sub>RAM</sub>	RAM keep-alive voltage		1.5	–	–	V
V <sub>IL</sub>	Input low voltage (TTL input)	4.0 V < V <sub>DD</sub> < 6.0 V	–0.5	–	0.2 V <sub>DD</sub> –0.1	V
		2.7 V < V <sub>DD</sub> < 4.0 V	–0.5	–	0.7	V
V <sub>IL1</sub>	Negative going threshold (Schmitt input)		–0.5	–	0.3 V <sub>DD</sub>	V
V <sub>IH</sub>	Input high voltage (TTL input)		0.2 V <sub>DD</sub> +0.9	–	V <sub>DD</sub> +0.5	V
V <sub>IH1</sub>	Positive going threshold (Schmitt input)		0.7V <sub>DD</sub>	–	V <sub>DD</sub> +0.5	V
HYS	Hysteresis voltage		–	0.2 V <sub>DD</sub>	–	V
V <sub>OL</sub>	Output low voltage all ports <sup>5, 9</sup>	I <sub>OL</sub> = 3.2 mA, V <sub>DD</sub> = 2.7 V	–	–	0.4	V
V <sub>OL1</sub>	Output low voltage all ports <sup>5, 9</sup>	I <sub>OL</sub> = 20 mA, V <sub>DD</sub> = 2.7 V	–	–	1.0	V
V <sub>OH</sub>	Output high voltage, all ports <sup>3</sup>	I <sub>OH</sub> = –20 μA, V <sub>DD</sub> = 2.7 V	V <sub>DD</sub> –0.7	–	–	V
		I <sub>OH</sub> = –30 μA, V <sub>DD</sub> = 4.5 V	V <sub>DD</sub> –0.7	–	–	V
V <sub>OH1</sub>	Output high voltage, all ports <sup>4</sup>	I <sub>OH</sub> = –1.0 mA, V <sub>DD</sub> = 2.7 V	V <sub>DD</sub> –0.7	–	–	V
C <sub>IO</sub>	Input/Output pin capacitance <sup>10</sup>		–	–	15	pF
I <sub>IL</sub>	Logical 0 input current, all ports <sup>8</sup>	V <sub>IN</sub> = 0.4 V	–	–	–50	μA
I <sub>LI</sub>	Input leakage current, all ports <sup>7</sup>	V <sub>IN</sub> = V <sub>IL</sub> or V <sub>IH</sub>	–	–	±2	μA
I <sub>TL</sub>	Logical 1 to 0 transition current, all ports <sup>3, 6</sup>	V <sub>IN</sub> = 1.5 V at V <sub>DD</sub> = 3.0 V	–30	–	–250	μA
		V <sub>IN</sub> = 2.0 V at V <sub>DD</sub> = 5.5 V	–150	–	–650	μA
R <sub>RST</sub>	Internal reset pull-up resistor		40	–	225	kΩ
V <sub>BOLOW</sub>	Brownout trip voltage with BOV = 1 <sup>12</sup>		2.35	–	2.69	V
V <sub>BOHI</sub>	Brownout trip voltage with BOV = 0		3.45	–	3.99	V

### NOTES:

1. Typical ratings are not guaranteed. The values listed are at room temperature, 5 V.
2. See other Figures for details.
3. Ports in quasi-bidirectional mode with weak pull-up (applies to all port pins with pull-ups). Does not apply to open drain pins.
4. Ports in PUSH-PULL mode. Does not apply to open drain pins.
5. In all output modes except high impedance mode.
6. Port pins source a transition current when used in quasi-bidirectional mode and externally driven from 1 to 0. This current is highest when V<sub>IN</sub> is approximately 2 V.
7. Measured with port in high impedance mode. Parameter is guaranteed but not tested at cold temperature.
8. Measured with port in quasi-bidirectional mode.
9. Under steady state (non-transient) conditions, I<sub>OL</sub> must be externally limited as follows:
 

Maximum I <sub>OL</sub> per port pin:	20 mA
Maximum total I <sub>OL</sub> for all outputs:	80 mA
Maximum total I <sub>OH</sub> for all outputs:	5 mA

 If I<sub>OL</sub> exceeds the test condition, V<sub>OL</sub> may exceed the related specification. Pins are not guaranteed to sink current greater than the listed test conditions.
10. Pin capacitance is characterized but not tested.
11. The I<sub>DD</sub>, I<sub>ID</sub>, and I<sub>PD</sub> specifications are measured using an external clock with the following functions disabled: comparators, brownout detect, and watchdog timer. For V<sub>DD</sub> = 3 V, LPEP = 1. Refer to the appropriate figures on the following pages for additional current drawn by each of these functions and detailed graphs for other frequency and voltage combinations.
12. Devices initially operating at V<sub>DD</sub> = 2.7 V or above, and at f<sub>OSC</sub> = 10 MHz or less, are guaranteed to continue to execute instructions correctly at the brownout trip point. Initial power-on operation below V<sub>DD</sub> = 2.7 V is not guaranteed.
13. Devices initially operating at V<sub>DD</sub> = 4.0 V or above and at f<sub>OSC</sub> = 20 MHz or less are guaranteed to continue to execute instructions correctly at the brownout trip point. Initial power-on operation below V<sub>DD</sub> = 4.0 V and f<sub>OSC</sub> > 10 MHz is not guaranteed.



# Low power, low price, low pin count (14 pin) microcontroller with 1 kbyte OTP

P87LPC759

## AC ELECTRICAL CHARACTERISTICS

$T_{amb} = 0\text{ }^{\circ}\text{C}$  to  $+70\text{ }^{\circ}\text{C}$ ,  $V_{DD} = 2.7\text{ V}$  to  $6.0\text{ V}$  unless otherwise specified;  $V_{SS} = 0\text{ V}$ <sup>1, 2, 3</sup>

SYMBOL	FIGURE	PARAMETER	LIMITS		UNIT	
			MIN	MAX		
<b>External Clock</b>						
$f_C$	29	Oscillator frequency ( $V_{DD} = 4.0\text{ V}$ to $6.0\text{ V}$ )	0	20	MHz	
$f_C$	29	Oscillator frequency ( $V_{DD} = 2.7\text{ V}$ to $6.0\text{ V}$ )	0	10	MHz	
$t_C$	29	Clock period and CPU timing cycle	$1/f_C$	–	ns	
$f_{CLCX}$	29	Clock low-time <sup>1</sup>	$f_{OSC} = 20\text{ MHz}$	20	–	ns
$f_{CLCX}$	29		$f_{OSC} = 10\text{ MHz}$	40	–	ns
$f_{CHCX}$	29	Clock high-time <sup>1</sup>	$f_{OSC} = 20\text{ MHz}$	20	–	ns
$f_{CHCX}$	29		$f_{OSC} = 10\text{ MHz}$	40	–	ns
<b>Internal RC Oscillator</b>						
$f_{CTOL}$		On-chip RC oscillator tolerance	$f_{RCOSC} = 6\text{ MHz}$	–10	+10	%
<b>Shift Register</b>						
$t_{XLXL}$		Serial port clock cycle time	$6t_C$	–	ns	
$t_{QVXH}$		Output data setup to clock rising edge	$5t_C - 133$	–	ns	
$t_{XHQX}$		Output data hold after clock rising edge	$1t_C - 80$	–	ns	
$t_{XHDV}$		Input data setup to clock rising edge	–	$5t_C - 133$	ns	
$t_{XHDX}$		Input data hold after clock rising edge	0	–	ns	

### NOTES:

1. Applies only to an external clock source, not when a crystal is connected to the X1 and X2 pins.
2. Tested at  $V_{DD} = 5.0\text{ V}$  and room temperature.
3. These parameters are characterized but not tested.

Low power, low price, low pin count (14 pin)  
microcontroller with 1 kbyte OTP

P87LPC759

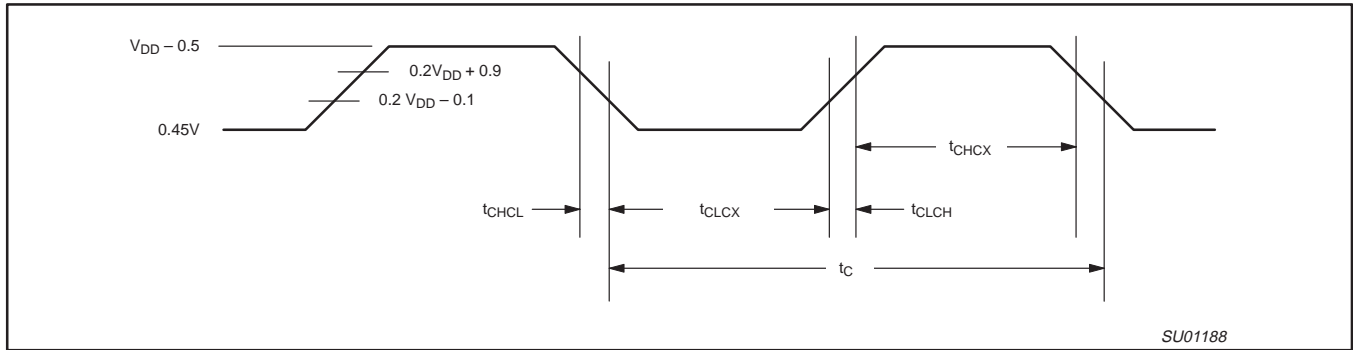

Figure 29. External Clock Timing

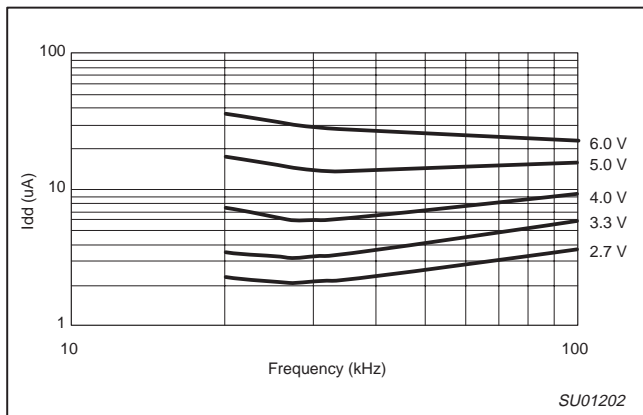

Figure 30. Typical I<sub>DD</sub> versus frequency (low frequency oscillator, 25 °C)

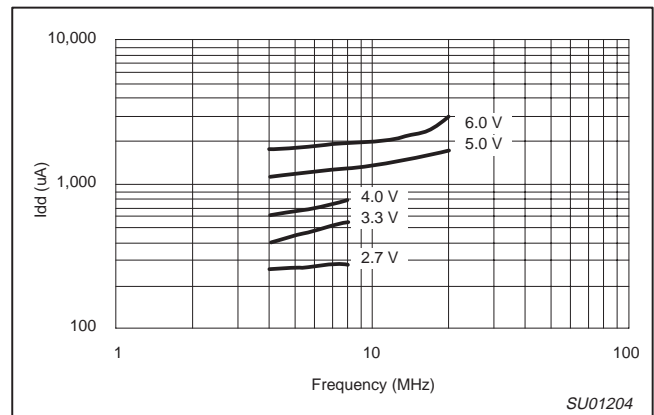

Figure 32. Typical I<sub>DD</sub> versus frequency (high frequency oscillator, 25 °C)

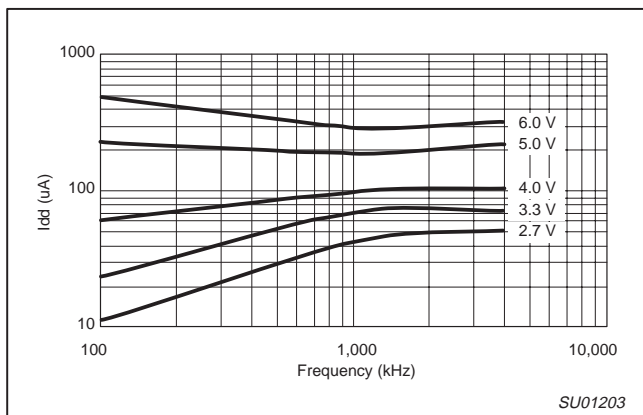

Figure 31. Typical I<sub>DD</sub> versus frequency (medium frequency oscillator, 25 °C)

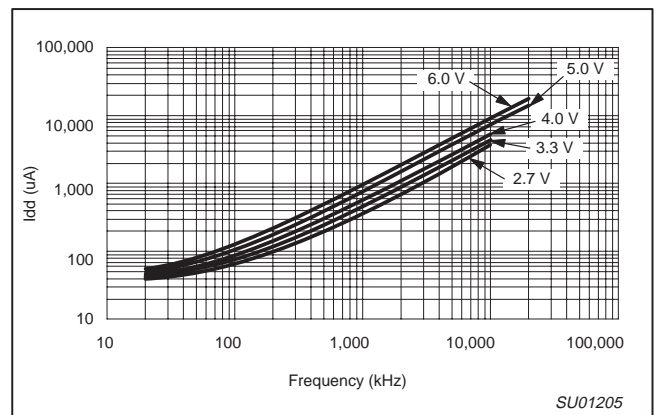

Figure 33. Typical Active I<sub>DD</sub> versus frequency (external clock, 25 °C, LPEP=0)

# Low power, low price, low pin count (14 pin) microcontroller with 1 kbyte OTP

## P87LPC759

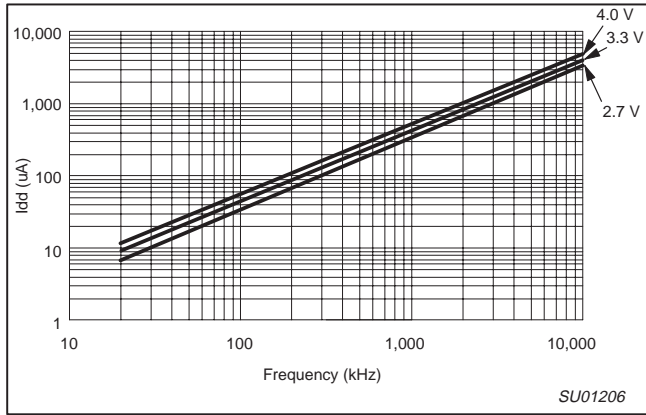

Figure 34. Typical Active Idd versus frequency (external clock, 25 °C, LPEP=1)

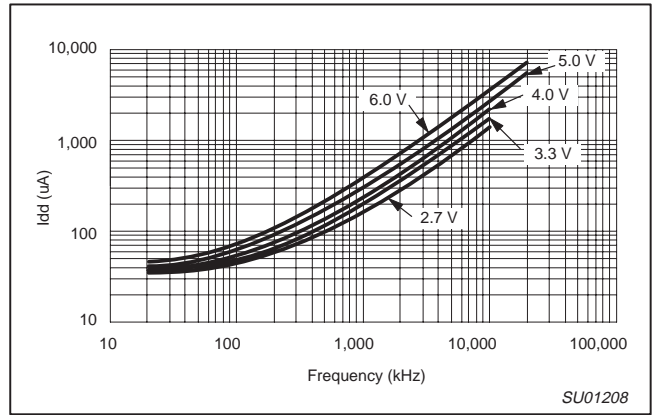

Figure 36. Typical Idle Idd versus frequency (external clock, 25 °C, LPEP=0)

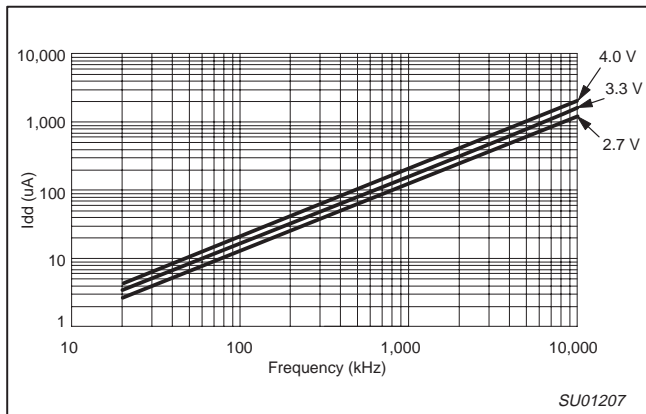

Figure 35. Typical Idle Idd versus frequency (external clock, 25 °C, LPEP=1)

Low power, low price, low pin count (14 pin)  
microcontroller with 1 kbyte OTP

P87LPC759

DIP14: plastic dual in-line package; 14 leads (300 mil)

SOT27-1

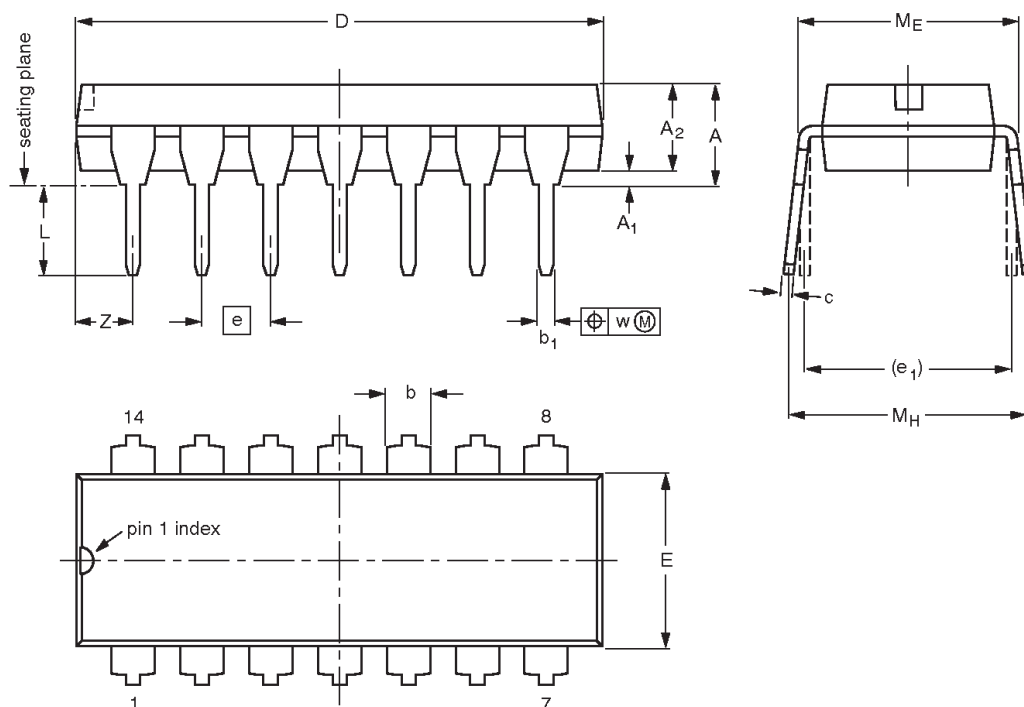

DIMENSIONS (inch dimensions are derived from the original mm dimensions)

UNIT	A max.	A1 min.	A2 max.	b	b1	c	D <sup>(1)</sup>	E <sup>(1)</sup>	e	e1	L	ME	MH	w	Z <sup>(1)</sup> max.
mm	4.2	0.51	3.2	1.73 1.13	0.53 0.38	0.36 0.23	19.50 18.55	6.48 6.20	2.54	7.62	3.60 3.05	8.25 7.80	10.0 8.3	0.254	2.2
inches	0.17	0.020	0.13	0.068 0.044	0.021 0.015	0.014 0.009	0.77 0.73	0.26 0.24	0.10	0.30	0.14 0.12	0.32 0.31	0.39 0.33	0.01	0.087

Note

1. Plastic or metal protrusions of 0.25 mm maximum per side are not included.

OUTLINE VERSION	REFERENCES				EUROPEAN PROJECTION	ISSUE DATE
	IEC	JEDEC	EIAJ			
SOT27-1	050G04	MO-001	SC-501-14			95-03-11 99-12-27

---

Low power, low price, low pin count (14 pin)  
microcontroller with 1 kbyte OTP

---

P87LPC759

**REVISION HISTORY**

Date	CPCN	Description
2002 Mar xx	9397 750	Initial release

# Low power, low price, low pin count (14 pin) microcontroller with 1 kbyte OTP

## P87LPC759

### Data sheet status

Data sheet status <sup>[1]</sup>	Product status <sup>[2]</sup>	Definitions
Objective data	Development	This data sheet contains data from the objective specification for product development. Philips Semiconductors reserves the right to change the specification in any manner without notice.
Preliminary data	Qualification	This data sheet contains data from the preliminary specification. Supplementary data will be published at a later date. Philips Semiconductors reserves the right to change the specification without notice, in order to improve the design and supply the best possible product.
Product data	Production	This data sheet contains data from the product specification. Philips Semiconductors reserves the right to make changes at any time in order to improve the design, manufacturing and supply. Changes will be communicated according to the Customer Product/Process Change Notification (CPCN) procedure SNW-SQ-650A.

[1] Please consult the most recently issued data sheet before initiating or completing a design.

[2] The product status of the device(s) described in this data sheet may have changed since this data sheet was published. The latest information is available on the Internet at URL <http://www.semiconductors.philips.com>.

### Definitions

**Short-form specification** — The data in a short-form specification is extracted from a full data sheet with the same type number and title. For detailed information see the relevant data sheet or data handbook.

**Limiting values definition** — Limiting values given are in accordance with the Absolute Maximum Rating System (IEC 60134). Stress above one or more of the limiting values may cause permanent damage to the device. These are stress ratings only and operation of the device at these or at any other conditions above those given in the Characteristics sections of the specification is not implied. Exposure to limiting values for extended periods may affect device reliability.

**Application information** — Applications that are described herein for any of these products are for illustrative purposes only. Philips Semiconductors make no representation or warranty that such applications will be suitable for the specified use without further testing or modification.

### Disclaimers

**Life support** — These products are not designed for use in life support appliances, devices or systems where malfunction of these products can reasonably be expected to result in personal injury. Philips Semiconductors customers using or selling these products for use in such applications do so at their own risk and agree to fully indemnify Philips Semiconductors for any damages resulting from such application.

**Right to make changes** — Philips Semiconductors reserves the right to make changes, without notice, in the products, including circuits, standard cells, and/or software, described or contained herein in order to improve design and/or performance. Philips Semiconductors assumes no responsibility or liability for the use of any of these products, conveys no license or title under any patent, copyright, or mask work right to these products, and makes no representations or warranties that these products are free from patent, copyright, or mask work right infringement, unless otherwise specified.

### Contact information

For additional information please visit  
<http://www.semiconductors.philips.com>. Fax: +31 40 27 24825

© Koninklijke Philips Electronics N.V. 2002  
 All rights reserved. Printed in U.S.A.

For sales offices addresses send e-mail to:  
[sales.addresses@www.semiconductors.philips.com](mailto:sales.addresses@www.semiconductors.philips.com)

Document order number:

Date of release: 03-02

9397 750

*Let's make things better.*