



November 2004

LM3557 Step-Up Converter for White LED Applications

General Description

The LM3557 is a complete solution for white LED drive applications. With minimal external component count, no DC current leakage paths to ground, cycle-by-cycle current limit protection, and output over-voltage protection circuitry, the LM3557 offer superior performance and cost savings over standard DC/DC boost component implementations.

The LM3557 switches at a fixed-frequency of 1.25 MHz, which allows for the use of small external components. Also, the LM3557 has a wide input voltage range to take advantage of multi-cell input applications. With small external components, high fixed frequency operation, and wide input voltage range, the LM3557 is the most optimal choice for LED lighting applications.

Features

- V_{IN} Range: 2.7V–7.5V
- Small External Components

- 1.25 MHz Constant-Switching Frequency
- Output Over-Voltage Protection
- Input Under-Voltage Protection
- Cycle-By-Cycle Current Limit
- TRUE SHUTDOWN: No DC current paths to ground during shutdown
- Low Profile Package: <1 mm Height -8 Pin LLP
- No External Compensation

Applications

- White LED Display Lighting
- Cellular Phones
- PDAs

Typical Application Circuit

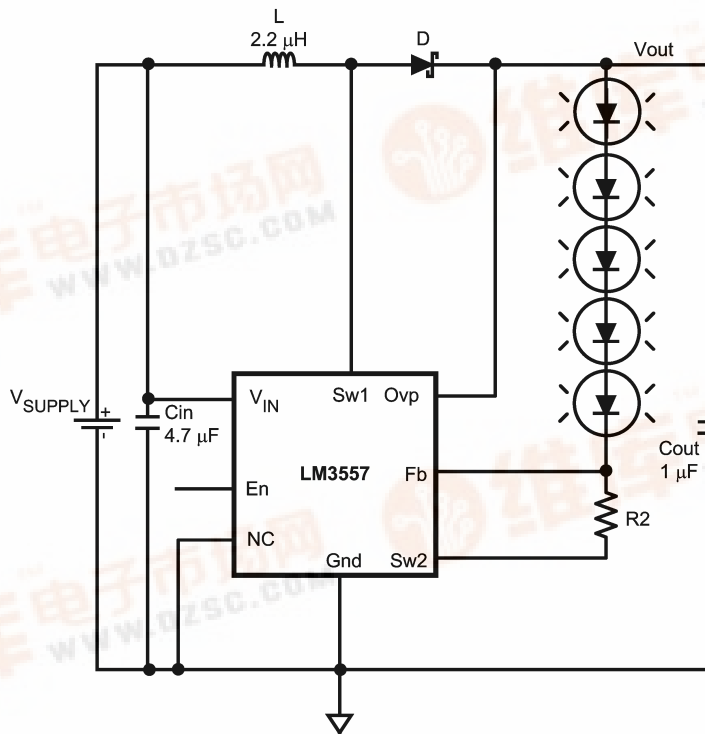

20131601

FIGURE 1. Backlight Configuration

LM3557 Step-Up Converter for White LED Applications



Connection Diagram

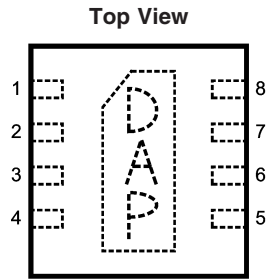

20131602

8-Lead Thin Leadless Leadframe Package
See NS Package Number SDA08A

Ordering Information

Order Number	Package Marking	Supplied As
LM3557SD-2	L147B	1k Units, Tape and Reel
LM3557SDX-2	L147B	4.5k Units, Tape and Reel

Pin Description

Pin #	Name	Description
1	Sw1	Drain Connection of the Internal Power Field Effect Transistor (FET) Switch (<i>Figure 2: N1</i>)
2	V _{IN}	Input Voltage Connection
3	NC	No Connection
4	En	Device Enable Connection
5	Ovp	Over-Voltage Protection Input Connection
6	Fb	Feedback Voltage Connection
7	Sw2	Drain Connection of an Internal Field Effect Transistor (FET) Switch (<i>Figure 2: N2</i>)
8	Gnd	Ground Connection
DAP	DAP	Die Attach Pad (DAP), must be soldered to the printed circuit board's ground plane for enhanced thermal dissipation

Absolute Maximum Ratings (Note 1)

If Military/Aerospace specified devices are required, please contact the National Semiconductor Sales Office/Distributors for availability and specifications.

V _{IN} Pin	-0.3V to +8V
En Pin	-0.3V to +8V
Fb Pin	-0.3V to +8V
Sw2 Pin	-0.3V to +8V
Ovp Pin	-0.3V to +30V
Sw1 Pin	-0.3V to +40V
Continuous Power Dissipation	Internally Limited
Maximum Junction Temperature (T _{J-MAX})	+150°C
Storage Temperature Range	-65°C to +150°C

ESD Rating (Note 2)

Human Body Model	2 kV
Machine Model	150V

Operating Conditions (Notes 1, 6)

Junction Temperature (T _J) Range	-40°C to +125°C
Ambient Temperature (T _A) Range	-40°C to +85°C
Supply Voltage, V _{IN} Pin	2.7V to 7.5V
En Pin	0V to V _{IN} +0.4V

Thermal Properties (Notes 4, 7)

Junction-to-Ambient Thermal Resistance (θ _{JA}), Leadless Leadframe Package	55°C/W
---	--------

Electrical Characteristics (Notes 6, 8) Limits in standard typeface are for T_J = 25°C. Limits in **bold typeface** apply over the full operating junction temperature range (-40°C ≤ T_J ≤ +125°C). Unless otherwise specified: V_{IN} = 3.6V.

Symbol	Parameter	Conditions	Min	Typ	Max	Units
V _{IN}	Input Voltage		2.7		7.5	V
I _Q	Quiescent Current	V _{EN} = 0V (Shutdown) V _{EN} = 1.8V; V _{OVP} = 27V (Non-Switching)		0.01 0.55	2 0.8	μA mA
En	Device Enable Threshold	Device On Device Off	0.9		0.3	V
I _{CL}	Power Switch Current Limit (Note 10)	V _{IN} = 3V	0.4 0.55	0.8 0.8	1.1 1.02	A
R _{DS(ON)}	Power Switch ON Resistance	I _{Sw1} = 175 mA		800	1000	mΩ
TC (R _{DS(ON)})	R _{DS(ON)} Temperature Coefficient			0.5		%/C
OVP	Over-Voltage Protection (Note 5)	On Threshold Off Threshold	22 21.5	26 25.5	28.5 28	V
UVP	Under-Voltage Protection (Note 5)	On Threshold Off Threshold		2.2 2.3		V
I _{OVP}	Over-Voltage Protection Pin Bias Current (Note 3)			4	10	μA
I _{EN}	Enable Pin Bias Current (Note 3)	V _{EN} = 1.8V		0.8	3	μA
F _S	Switching Frequency	V _{IN} = 3V	0.9	1.25	1.6	MHz
V _{Fb-Sw2}	Feedback Pin Voltage (Note 9)		0.459	0.51	0.561	V
I _{Fb}	Feedback Pin Bias Current (Note 3)			0.03	2	μA
D _{MAX}	Maximum Duty Cycle	V _{IN} = 3V	85	90		%
I _{LSw1}	Sw1 Pin Leakage Current (Note 3)	V _{Sw1} = 3.6V, Not Switching		0.002	2	μA
I _{LSw2}	Sw2 Pin Leakage Current (Note 3)	V _{Sw2} = 3.6V, Not Switching		0.001	1	μA
I _{LOVP}	Ovp Pin Leakage Current (Note 3)	V _{Ovp} = 3.6V, Not Switching		2		nA
R _{Sw2}	Sw2 Pin Switch Resistance	I _{Sw2} = 50 mA		8	10	Ω
TC(R _{Sw2})	R _{Sw2} Temperature Coefficient			0.5		%/C

Note 1: Absolute maximum ratings indicate limits beyond which damage to the device may occur. Electrical characteristic specifications do not apply when operating the device outside of its rated operating conditions.

Note 2: The human body model is a 100 pF capacitor discharged through a 1.5 kΩ resistor into each pin. The machine model is a 200 pF capacitor discharged directly into each pin.

Note 3: Current flows into the pin.

Note 4: The maximum allowable power dissipation is a function of the maximum junction temperature, $T_J(\text{MAX})$, the junction-to-ambient thermal resistance, θ_{JA} , and the ambient temperature, T_A . See Thermal Properties for the thermal resistance. The maximum allowable power dissipation at any ambient temperature is calculated using: $P_D(\text{MAX}) = (T_J(\text{MAX}) - T_A) / \theta_{JA}$. Exceeding the maximum allowable power dissipation will cause excessive die temperature.

Note 5: The on threshold indicates that the LM3557 is no longer switching or regulating LED current, while the off threshold indicates normal operation.

Note 6: All voltages are with respect to the potential at the GND pin.

Note 7: Junction-to-ambient thermal resistance (θ_{JA}) is taken from a thermal modeling result, performed under the conditions and guidelines set forth in the JEDEC standard JESD51-7. The test board is a 4 layer FR-4 board measuring 102 mm x 76 mm x 1.6 mm with a 2 x 1 array of thermal vias. The ground plane on the board is 50 mm x 50 mm. Thickness of copper layers are 36 μm /18 μm /18 μm /36 μm (1.5 oz/1 oz/1 oz/1.5 oz). Ambient temperature in simulation is 22°C, still air. Power dissipation is 1W.

In applications where high maximum power dissipation exists, special care must be paid to thermal dissipation issues. For more information on these topics, please refer to **Application Note 1187: Leadless Leadframe Package (LLP)** and the **Layout Guidelines** section of this datasheet.

Note 8: Min and Max limits are guaranteed by design, test, or statistical analysis. Typical numbers are not guaranteed, but do represent the most likely norm.

Note 9: Feedback pin voltage is with respect to the voltage at the Sw2 pin.

Note 10: The Power Switch Current Limit is tested in open loop configuration. For closed loop application current limit please see the Current Limit vs Temperature performance graph.

Block Diagram

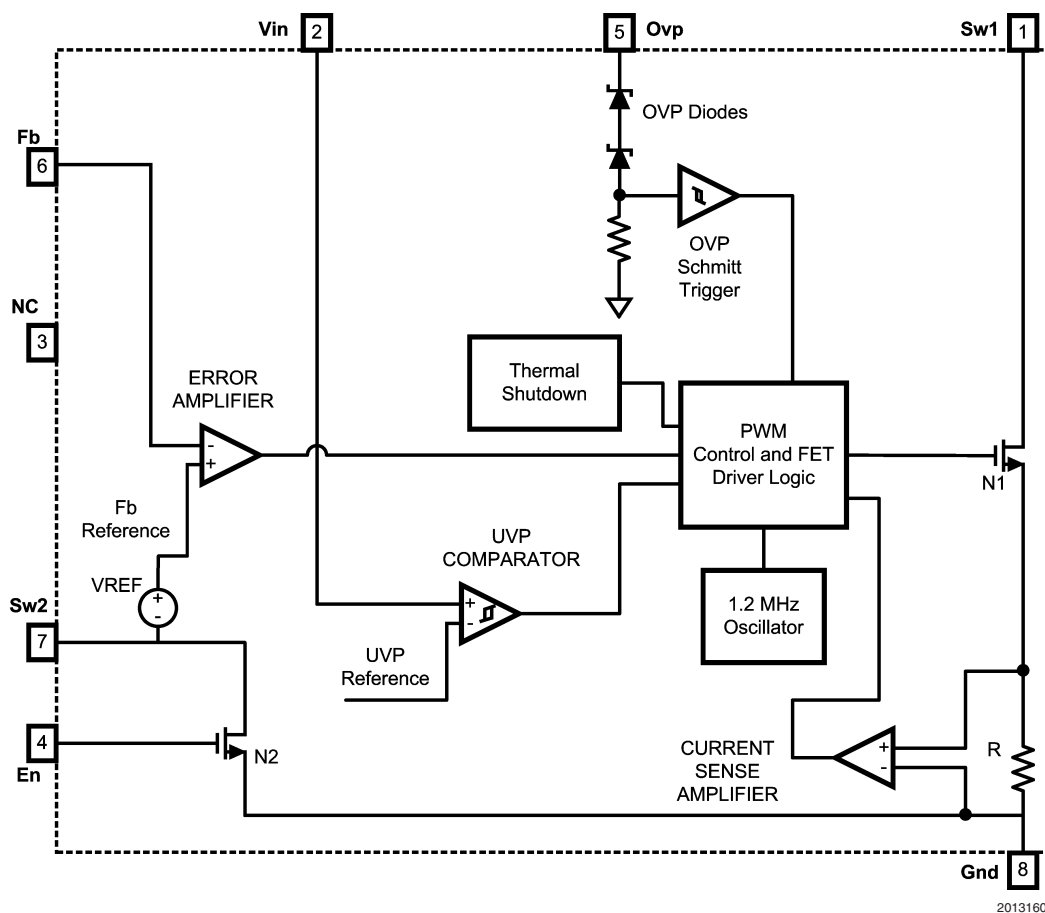

FIGURE 2. Block Diagram

Operation

The LM3557 is a current-mode controlled constant-frequency step-up converter optimized for the facilitation of white LED driving/current biasing.

The LM3557's operation can be best understood by the following device functionality explanation. For the following device functionality explanation, the block diagram in *Figure 2* serves as a functional schematic representation of the underlying circuit blocks that make up the LM3557. When the feedback voltage falls below, or rises above, the internal

reference voltage, the error amplifier outputs a signal that is translated into the correct amount of stored energy within the inductor that is required to put the feedback voltage back into regulation when the stored inductor energy is then transferred to the load. The aforementioned translation is a conversion of the error amplifier's output signal to the proper on-time duration of the N1 power field effect transistor (FET). This conversion allows the inductor's stored energy to increase, or decrease, to a sufficient level that when transferred to the load will bring the feedback voltage back into regulation.

Operation (Continued)

An increase in inductor current corresponds to an increase in the amount of stored energy within the inductor. Conversely, a decrease in inductor current corresponds to a decrease in the amount of stored energy. The inductor's stored energy is released, or transferred, to the load when the N1 power FET is turned off. The transferred inductor energy replenishes the output capacitor and keeps the white LED current regulated at the designated magnitude that is based on the choice of the R2 resistor. When the N1 power FET is turned on, the energy stored within the inductor begins to increase while the output capacitor discharges through the series string of white LEDs, the R2 resistance, and N2 FET switch to ground. Therefore, each switching cycle consist of some amount of energy being stored in the inductor that is then released, or transferred, to the load to keep the voltage at the feedback pin in regulation at 510 mV above the Sw2 pin voltage.

Features:

CYCLE-BY-CYCLE CURRENT LIMIT

The current through the internal power FET (Figure 2: N1) is monitored to prevent peak inductor currents from damaging the part. If during a cycle (cycle = 1/switching frequency) the peak inductor current exceeds the current limit rating for the LM3557, the internal power FET would be forcibly turned off for the remaining duration of that cycle.

Typical Performance Characteristics

(Circuit in Figure 1: L = DO1608C-223, D = SS16, and LED = LWT67C. Efficiency: $\eta = P_{OUT}/P_{IN} = [(V_{OUT} - V_{FB}) * I_{OUT}]/[V_{IN} * I_{IN}]$. $T_A = 25^\circ\text{C}$, unless otherwise stated).

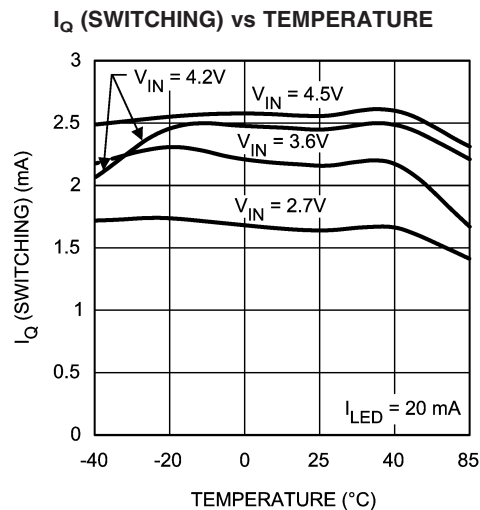

20131604

SWITCHING FREQUENCY vs TEMPERATURE

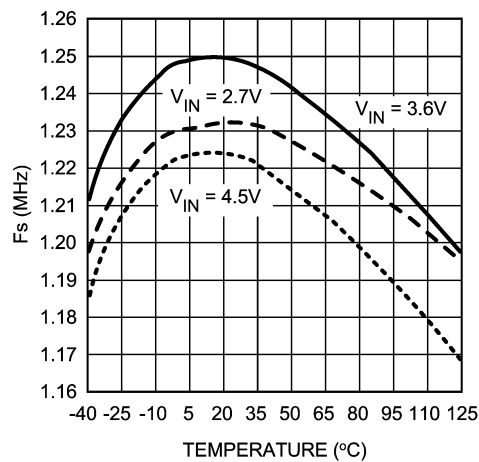

20131605

OVER-VOLTAGE PROTECTION

When the output voltage exceeds the over-voltage protection (OVP) threshold, the LM3557's internal power FET will be forcibly turned off until the output voltage falls below the over-voltage protection threshold minus the 500 mV hysteresis of the internal OVP circuitry.

UNDER-VOLTAGE PROTECTION

When the input voltage falls below the under-voltage protection (UVP) threshold, the LM3557's internal power FET will be forcibly turned off until the input voltage is above the designated under-voltage protection threshold plus the 100 mV hysteresis of the internal UVP circuitry.

TRUE SHUTDOWN

When the LM3557 is put into shutdown mode operation there are no DC current paths to ground. The internal FET (Figure 2: N2) at the Sw2 pin turns off, leaving the white LED string open circuited.

THERMAL SHUTDOWN

When the internal semiconductor junction temperature reaches approximately 150°C , the LM3557's internal power FET (Figure 2: N1) will be forcibly turned off.

Typical Performance Characteristics (Circuit in Figure 1: L = DO1608C-223, D = SS16, and LED = LWT67C. Efficiency: $\eta = P_{OUT}/P_{IN} = [(V_{OUT} - V_{FB}) * I_{OUT}]/[V_{IN} * I_{IN}]$. $T_A = 25^\circ\text{C}$, unless otherwise stated). (Continued)

En PIN CURRENT vs En PIN VOLTAGE

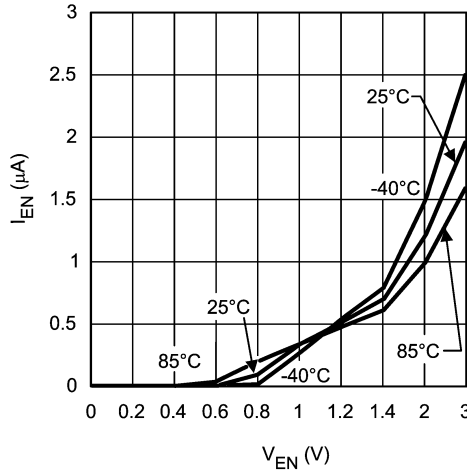

20131608

CURRENT LIMIT vs TEMPERATURE

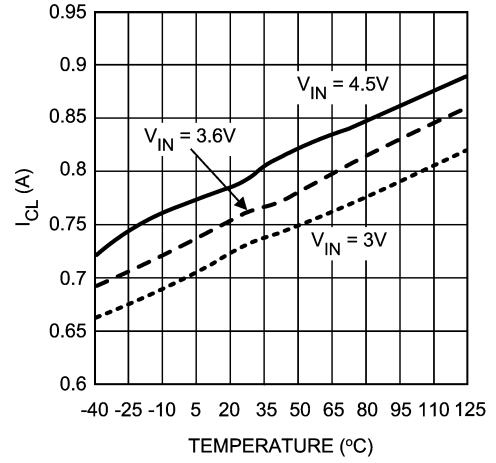

20131609

OVP PIN CURRENT vs TEMPERATURE

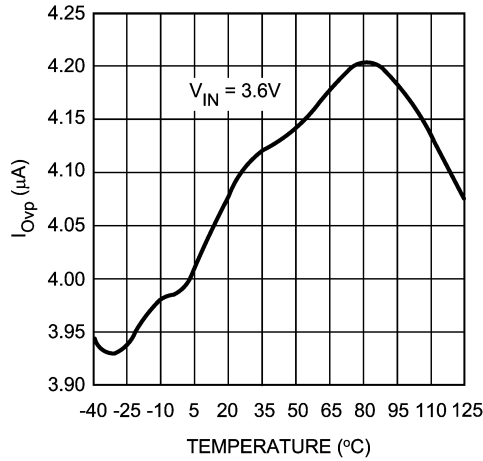

20131610

R_DS(ON) (Figure 2: N1) vs TEMPERATURE

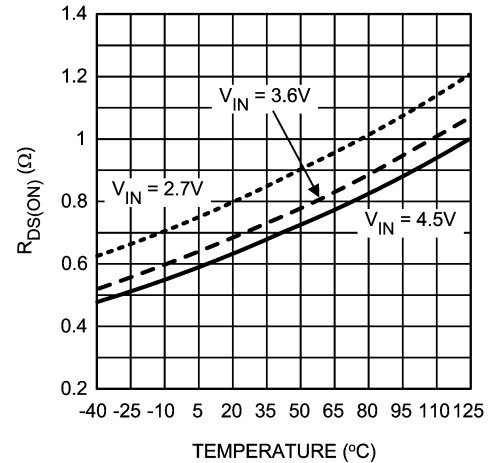

20131611

R_SW2 (Figure 2: N2) vs TEMPERATURE

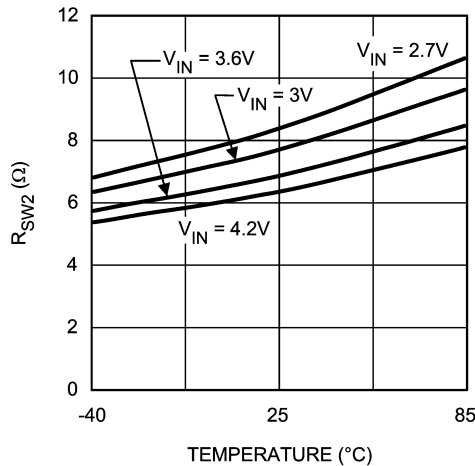

20131612

ENABLE THRESHOLD vs TEMPERATURE

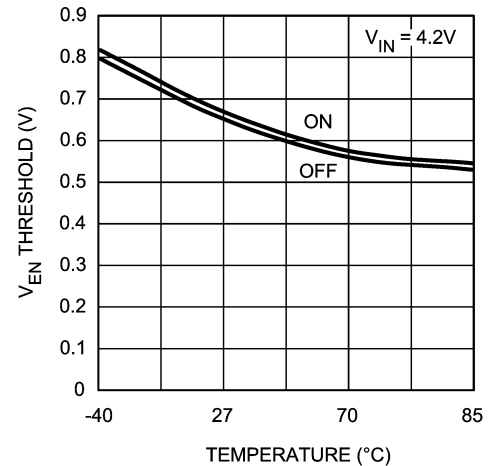

20131613

Application Information

Application Information (Continued)

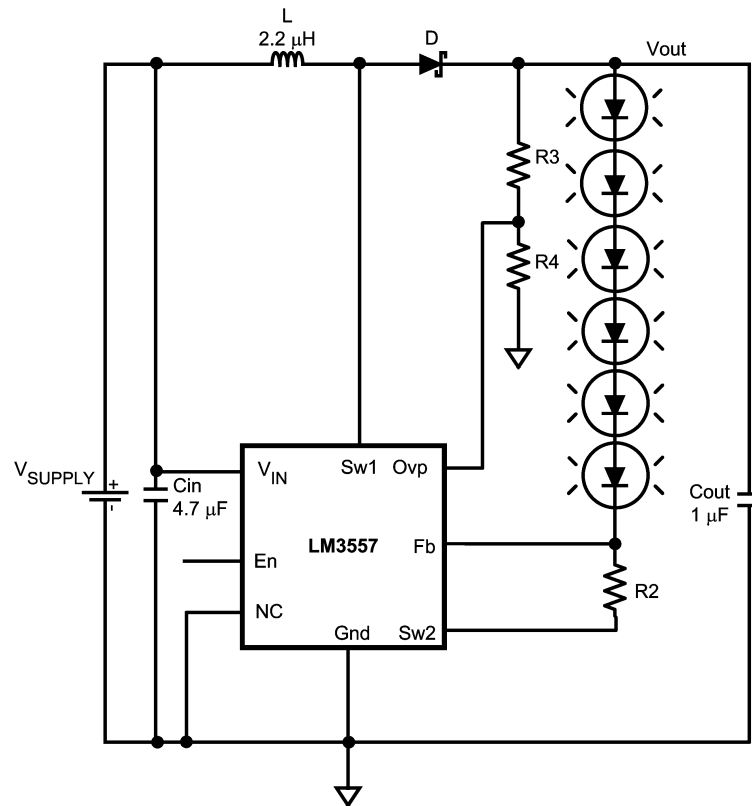

20131616

FIGURE 3. Programmable Output Voltage

WHITE LED CURRENT SETTING

For backlighting applications, the white LED current is programmed by the careful choice of the R2 resistor.

Backlight:

$$V_{En} \geq 0.9V$$

$$I_{LED} = \frac{V_{Fb-Sw2}}{R2}$$

20131617

I_{LED} : White LED Current.

V_{Fb-Sw2} : Feedback Voltage.

R2: Resistor.

The feedback voltage is with respect to the voltage at the Sw2 pin, not ground. For example, if the voltage on the Sw2 pin were 0.1V then the voltage at the Fb pin would be 0.61V (typical).

ADJUSTING OVER-VOLTAGE PROTECTION

If the over-voltage protection (OVP) threshold is too low for a particular application, a resistor divider circuit can be used to

adjust the OVP threshold of a given application. Instead of having the Ovp pin connected to the output voltage, it can be adjusted through a resistor divider circuit to only experience a fraction of the output voltage magnitude. The resistor divider circuit bias current should be at least 100 times greater than the Ovp pin bias current. Using *Figure 3*, the following equation can be used to adjust the output voltage:

$$V_{out} = \frac{[R4 + R3]}{[R4]} \times V_{Ovp}$$

20131618

V_{OVP} : OVP Voltage Threshold.

V_{OUT} : Maximum Output Voltage (<35V).

R3: Resistor.

R4: Resistor.

Application Information (Continued)

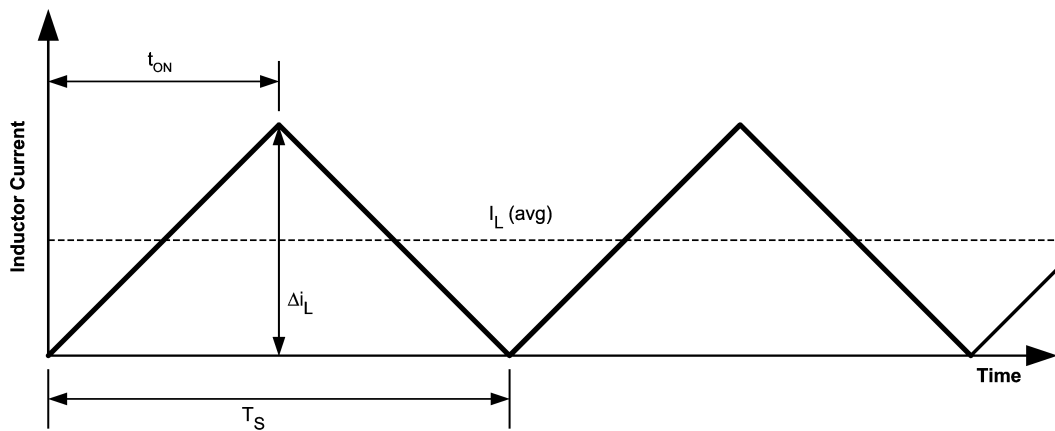

20131619

FIGURE 4. Inductor Current Waveform

CONTINUOUS AND DISCONTINUOUS MODES OF OPERATION

Since the LM3557 is a constant frequency pulse-width-modulated step-up regulator, care must be taken to make sure the maximum duty cycle specification is not violated. The duty cycle equation depends on which mode of operation the LM3557 is in. The two operational modes of the LM3557 are continuous conduction mode (CCM) and discontinuous conduction mode (DCM). Continuous conduction mode refers to the mode of operation where during the switching cycle, the inductor's current never goes to and stays at zero for any significant amount of time during the switching cycle. Discontinuous conduction mode refers to the mode of operation where during the switching cycle, the inductor's current goes to and stays at zero for a significant amount of time during the switching cycle. *Figure 4* illustrates the threshold between CCM and DCM operation. In *Figure 4*, the inductor current is right on the CCM/DCM operational threshold. Using this as a reference, a factor can be introduced to calculate when a particular application is in CCM or DCM operation. R is a CCM/DCM factor we can use to compute which mode of operation a particular application is in. If R is ≥ 1 , then the application is operating in CCM. Conversely, if R is < 1 , the application is operating in DCM. The R factor inequalities are a result of the components that make up the R factor. From *Figure 4*, the R factor is equal to the average inductor current, $I_L(\text{avg})$, divided by half the inductor ripple current, Δi_L . Using *Figure 4*, the following equation can be used to compute R factor:

$$R = \frac{2 \times I_L(\text{avg})}{\Delta i_L}$$

20131620

$$I_L(\text{avg}) = \frac{[I_{\text{OUT}}]}{[(1-D) \times \text{Eff}]}$$

20131621

$$\Delta i_L = \frac{[V_{\text{IN}} \times D]}{[L \times F_s]}$$

20131622

$$R = \frac{[2 \times I_{\text{OUT}} \times L \times F_s \times (V_{\text{OUT}})^2]}{[(V_{\text{IN}})^2 \times \text{Eff} \times (V_{\text{OUT}} - V_{\text{IN}})]}$$

20131623

- V_{IN} : Input Voltage.
 V_{OUT} : Output Voltage.
 Eff: Efficiency of the LM3557.
 F_s : Switching Frequency.
 I_{OUT} : White LED Current/Load Current.
 L: Inductance Magnitude/Inductor Value.
 D: Duty Cycle for CCM operation.
 Δi_L : Inductor Ripple Current.
 $I_L(\text{avg})$: Average Inductor Current.
 For CCM operation, the duty cycle can be computed with:

$$D = \frac{t_{\text{ON}}}{T_S}$$

20131624

$$D = \frac{[V_{\text{OUT}} - V_{\text{IN}}]}{[V_{\text{OUT}}]}$$

20131625

- t_{ON} : Internal Power FET On-Time.
 T_S : Switching Period of Operation.
 D: Duty Cycle for CCM Operation.
 V_{OUT} : Output Voltage.
 V_{IN} : Input Voltage.
 For DCM operation, the duty cycle can be computed with:

Application Information (Continued)

$$D = \frac{t_{ON}}{T_S}$$

20131626

$$D = \sqrt{\frac{[2 \times I_{OUT} \times L \times (V_{OUT} - V_{IN}) \times Fs]}{[(V_{IN})^2 \times Eff]}}$$

20131627

- t_{ON} : Internal Power FET On-Time.
 T_S : Switching Period of Operation.
 D : Duty Cycle for DCM Operation.
 V_{OUT} : Output Voltage.
 V_{IN} : Input Voltage.
 I_{OUT} : White LED Current/Load Current.
 Fs : Switching Frequency.
 Eff : Efficiency of the LM3557.
 L : Inductor Value/Inductance Magnitude.

INDUCTOR SELECTION

In order to maintain inductance, an inductor used with the LM3557 should have a saturation current rating larger than the peak inductor current of the particular application. Inductors with low DCR values contribute decreased power losses and increased efficiency. The peak inductor current can be computed for both modes of operation: CCM (continuous current mode) and DCM (discontinuous current mode).

The cycle-by-cycle peak inductor current for CCM operation can be computed with:

$$I_{Peak} \approx I_L (avg) + \frac{\Delta i_L}{2}$$

20131628

$$I_{Peak} \approx \frac{[I_{OUT}]}{[(1 - D) \times Eff]} + \frac{[V_{IN} \times D]}{[2 \times L \times Fs]}$$

20131629

- V_{IN} : Input Voltage.
 Eff : Efficiency of the LM3557.
 Fs : Switching Frequency.
 I_{OUT} : White LED Current/Load Current.
 L : Inductance Magnitude/Inductor Value.
 D : Duty Cycle for CCM Operation.
 I_{Peak} : Peak Inductor Current.
 Δi_L : Inductor Ripple Current.
 $I_L (avg)$: Average Inductor Current.
 The cycle-by-cycle peak inductor current for DCM operation can be computed with:

$$I_{Peak} \approx \frac{[V_{IN} \times D]}{[L \times Fs]}$$

20131630

- V_{IN} : Input Voltage.
 Fs : Switching Frequency.
 L : Inductance Magnitude/Inductor Value.

D : Duty Cycle for DCM Operation.

I_{Peak} : Peak Inductor Current.

Some recommended inductor manufacturers are as follows:

Coilcraft [www.coilcraft.com]

Coiltronics [www.cooperet.com]

TDK [www.tdk.com]

CAPACITOR SELECTION

Multilayer ceramic capacitors are the best choice for use with the LM3557. Multilayer ceramic capacitors have the lowest equivalent series resistance (ESR). Applied voltage or DC bias, temperature, dielectric material type (X7R, X5R, Y5V, etc), and manufacturer component tolerance have an affect on the true or effective capacitance of a ceramic capacitor. Be aware of how your application will affect a particular ceramic capacitor by analyzing the aforementioned factors of your application. Before selecting a capacitor always consult the capacitor manufacturer's data curves to verify the effective or true capacitance of the capacitor in your application.

INPUT CAPACITOR SELECTION

The input capacitor serves as an energy reservoir for the inductor. In addition to acting as an energy reservoir for the inductor the input capacitor is necessary for the reduction in input voltage ripple and noise experienced by the LM3557. The reduction in input voltage ripple and noise helps ensure the LM3557's proper operation, and reduces the effect of the LM3557 on other devices sharing the same supply voltage. To ensure low input voltage ripple, the input capacitor must have an extremely low ESR. As a result of the low input voltage ripple requirement multilayer ceramic capacitors are the best choice. A minimum capacitance of 2.0 μF is required for normal operation, consult the capacitor manufacturer's data curves to verify whether the minimum capacitance requirement is going to be achieved for a particular application.

OUTPUT CAPACITOR SELECTION

The output capacitor serves as an energy reservoir for the white LED load when the internal power FET switch (*Figure 2: N1*) is ON or conducting current. The requirements for the output capacitor must include worst case operation such as when the load opens up and the LM3557 operates in over-voltage protection (OVP) mode operation. A minimum capacitance of 0.5 μF is required to ensure normal operation. Consult the capacitor manufacturer's data curves to verify whether the minimum capacitance requirement is going to be achieved for a particular application.

Some recommended capacitor manufacturers are as follows:

TDK

[www.tdk.com]

Murata

[www.murata.com]

Vishay

[www.vishay.com]

DIODE SELECTION

To maintain high efficiency it is recommended that the average current rating (I_F or I_O) of the selected diode should be larger than the peak inductor current (I_{LPeak}). To maintain diode integrity the peak repetitive forward current (I_{FRM}) must be greater than or equal to the peak inductor current (I_{LPeak}). Diodes with low forward voltage ratings (V_F) and low

Application Information (Continued)

junction capacitance magnitudes (C_J or C_T or C_D) are conducive to high efficiency. The chosen diode must have a reverse breakdown voltage rating (V_R and/or V_{RRM}) that is larger than the output voltage (V_{OUT}). No matter what type of diode is chosen, Schottky or not, certain selection criteria must be followed:

1. V_R and $V_{RRM} > V_{OUT}$
2. I_F or $I_O \geq I_{LOAD}$ or I_{OUT}
3. $I_{FRM} \geq I_{Lpeak}$

Some recommended diode manufacturers are as follows:

Vishay [www.vishay.com]

Diodes, Inc [www.diodes.com]

On Semiconductor [www.onsemi.com]

LAYOUT CONSIDERATIONS

All components, except for the white LEDs, must be placed as close as possible to the LM3557. The die attach pad (DAP) must be soldered to the ground plane.

The input capacitor, C_{in} , must be placed close to the LM3557. Placing C_{in} close to the device will reduce the metal trace resistance effect on input voltage ripple. The feedback current setting resistor $R2$ must be placed close to the Fb and $Sw2$ pins. The output capacitor, C_{out} , must be placed close to the Ovp and Gnd pin connections. Trace connections to the inductor should be short and wide to reduce power dissipation, increase overall efficiency, and reduce EMI radiation. The diode, like the inductor, should have trace connections that are short and wide to reduce power dissipation and increase overall efficiency. For more details regarding layout guidelines for switching regulators refer to Applications Note AN-1149.

Physical Dimensions inches (millimeters) unless otherwise noted

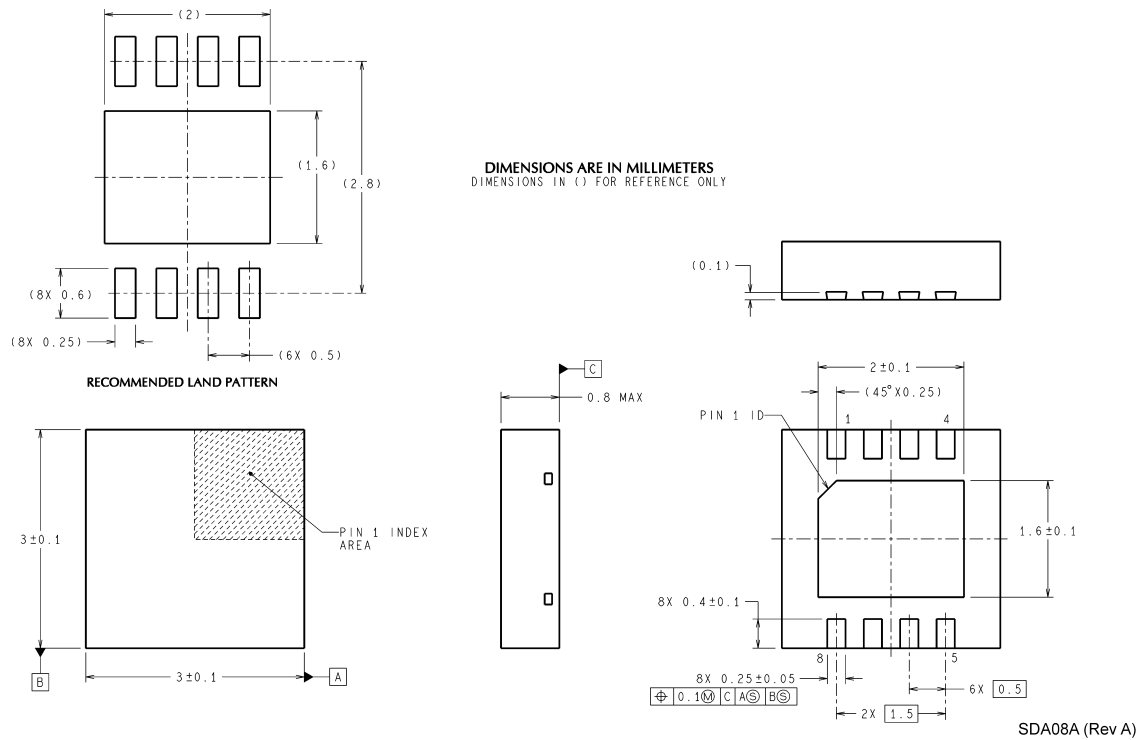

**8-Lead Thin Leadless Leadframe Package
NS Package Number SDA08A**

National does not assume any responsibility for use of any circuitry described, no circuit patent licenses are implied and National reserves the right at any time without notice to change said circuitry and specifications.

For the most current product information visit us at www.national.com.

LIFE SUPPORT POLICY

NATIONAL'S PRODUCTS ARE NOT AUTHORIZED FOR USE AS CRITICAL COMPONENTS IN LIFE SUPPORT DEVICES OR SYSTEMS WITHOUT THE EXPRESS WRITTEN APPROVAL OF THE PRESIDENT AND GENERAL COUNSEL OF NATIONAL SEMICONDUCTOR CORPORATION. As used herein:

1. Life support devices or systems are devices or systems which, (a) are intended for surgical implant into the body, or (b) support or sustain life, and whose failure to perform when properly used in accordance with instructions for use provided in the labeling, can be reasonably expected to result in a significant injury to the user.
2. A critical component is any component of a life support device or system whose failure to perform can be reasonably expected to cause the failure of the life support device or system, or to affect its safety or effectiveness.

BANNED SUBSTANCE COMPLIANCE

National Semiconductor certifies that the products and packing materials meet the provisions of the Customer Products Stewardship Specification (CSP-9-111C2) and the Banned Substances and Materials of Interest Specification (CSP-9-111S2) and contain no "Banned Substances" as defined in CSP-9-111S2.



**National Semiconductor
Americas Customer
Support Center**
Email: new.feedback@nsc.com
Tel: 1-800-272-9959

**National Semiconductor
Europe Customer Support Center**
Fax: +49 (0) 180-530 85 86
Email: europe.support@nsc.com
Deutsch Tel: +49 (0) 69 9508 6208
English Tel: +44 (0) 870 24 0 2171
Français Tel: +33 (0) 1 41 91 8790

**National Semiconductor
Asia Pacific Customer
Support Center**
Email: ap.support@nsc.com

**National Semiconductor
Japan Customer Support Center**
Fax: 81-3-5639-7507
Email: jpn.feedback@nsc.com
Tel: 81-3-5639-7560