



**Integrated
Circuit
Systems, Inc.**

ICS9148-82

Frequency Generator & Integrated Buffers for PENTIUM/Pro™

General Description

The ICS9148-82 generates all clocks required for high speed RISC or CISC microprocessor systems such as Intel PentiumPro or Cyrix. Eight different reference frequency multiplying factors are externally selectable with smooth frequency transitions.

Spread spectrum may be enabled through I²C programming. Spread spectrum typically reduces system EMI by 8dB to 10dB. This simplifies EMI qualification without resorting to board design iterations or costly shielding. The ICS9148-82 employs a proprietary closed loop design, which tightly controls the percentage of spreading over process and temperature variations.

Serial programming I²C interface allows changing functions, stop clock programming and frequency selection. The SDRAM12 output may be used as a feed back into an off chip PLL.

Features

- Generates the following system clocks:
 - 3 CPU(2.5V/3.3V) upto 100MHz.
 - 6 PCI(3.3V) @ 33.3MHz
 - 3AGP(3.3V) @ 2x PCI
 - 13 SDRAMs(3.3V) up to 100MHz
 - 1 REF(3.3V) @ 14.318MHz
- Skew characteristics:
 - CPU – CPU ≤ 250ps
 - CPU(early) – PCI : 1-4ns, Center 2.6ns
 - AGP - PCI: 500ps
- Supports Spread Spectrum modulation & I²C programming for Power Management, Frequency Select
- Efficient Power management scheme through PCI and CPU STOPCLOCKS.
- Uses external 14.318MHz crystal
- 48 pin 300mil SSOP.

Block Diagram

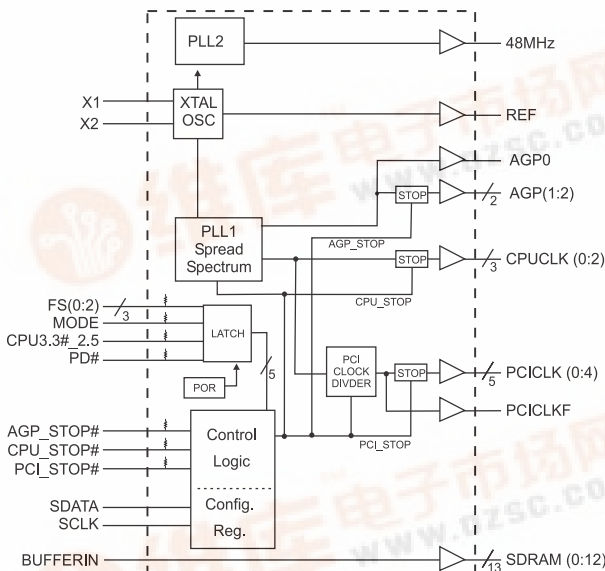

Power Groups

- VDD1 = REF (0:1), X1, X2
- VDD2 = PCICLK_F, PCICLK(0:5)
- VDD3 = SDRAM (0:12), supply for PLL core
- VDD4 = AGP(1:2)
- VDD5 = Fixed PLL, 48MHz, AGP0
- VDDL = CPUCLK (0:2)

Pin Configuration

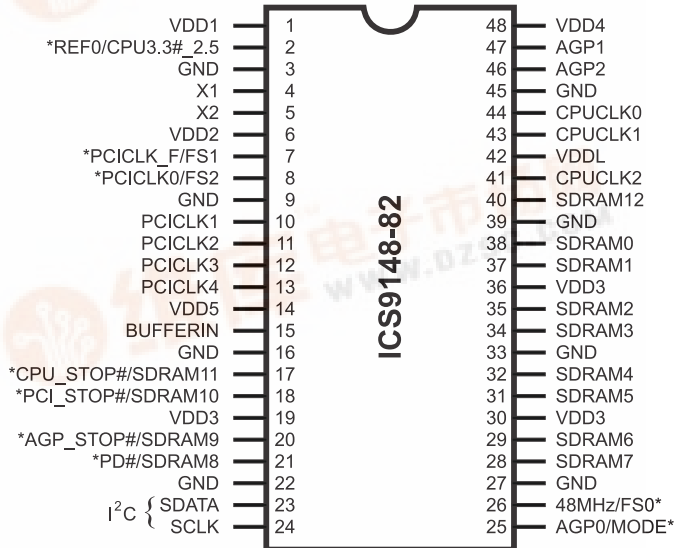

48-Pin SSOP

* Internal Pull-up Resistor of 240K to 3.3V on indicated inputs



Pin Descriptions

PIN NUMBER	PIN NAME	TYPE	DESCRIPTION
1	VDD1	PWR	Ref (0:2), XTAL power supply, nominal 3.3V
2	REF0	OUT	14.318 Mhz reference clock.
	CPU3.3#_2.5 ^{1,2}	IN	Indicates whether VDDL2 is 3.3V or 2.5V. High=2.5V CPU, LOW=3.3V CPU ¹ . Latched input ²
3,9,16,22,27,33,39,45	GND	PWR	Ground
4	X1	IN	Crystal input, has internal load cap (33pF) and feedback resistor from X2
5	X2	OUT	Crystal output, nominally 14.318MHz. Has internal load cap (33pF)
6	VDD2	PWR	Supply for PCICLK_F and PCICLK (0:5), nominal 3.3V
7	PCICLK_F	OUT	Free running PCI clock output. Synchronous with CPUCLKs with 1-4ns skew (CPU early) This is not affected by PCI_STOP#
	FS1 ^{1,2}	IN	Frequency select pin. Latched Input. Along with other FS pins determines the CPU, SDRAM, PCI & AGP frequencies.
8	PCICLK0	OUT	PCI clock outputs. Synchronous CPUCLKs with 1-4ns skew (CPU early)
	FS2 ^{1,2}	IN	Frequency select pin. Latched Input
10, 11, 12, 13	PCICLK(1:4)	OUT	PCI clock outputs. Synchronous CPUCLKs with 1-4ns skew (CPU early)
14	VDD5	PWR	Supply for fixed PLL, 48MHz, AGP0
15	BUFFERIN	IN	Input pin for SDRAM buffers.
17	CPU_STOP# ¹	IN	Halts CPUCLK (0:3) clocks at logic 0 level, when input low (in Mobile Mode, MODE=0)
	SDRAM 11	OUT	SDRAM clock output
18	PCI_STOP# ¹	IN	Halts PCICLK(0:5) clocks at logic 0 level, when input low (In mobile mode, MODE=0)
	SDRAM 10	OUT	SDRAM clock output
28, 29, 31, 32, 34, 35,37,38	SDRAM (0:9)	OUT	SDRAM clock outputs.
20	AGP_STOP#	IN	This asynchronous input halts AGP(1:2) clocks at logic "0" level when input low (in Mobile Mode, MODE=0) Does not affect AGP0
	SDRAM9	OUT	SDRAM clock output
21	PD#	IN	This asynchronous Power Down input Stops the VCO, crystal & internal clocks when active, Low. (In Mobile Mode, MODE=0)
	SDRAM8	OUT	SDRAM clock output
19,30,36	VDD3	PWR	Supply for SDRAM (0:11), CPU Core, 48MHz clocks, nominal 3.3V.
23	SDATA	IN	Data input for I ² C serial input.
24	SCLK	IN	Clock input of I ² C input
25	AGP0	OUT	Advanced Graphic Port output, powered by VDD4. Not affected by AGP_STOP#
	MODE ^{1,2}	IN	Pin 17, 18, 20 & 21 function select pin, 1=Desktop Mode, 0=Mobile Mode. Latched Input.
26	48MHz	OUT	48MHz output clock for USB timing.
	FS0 ^{1,2}	IN	Frequency select pin. Latched Input. Along with other FS pins determines the CPU, SDRAM, PCI & AGP frequencies.
41, 43, 44	CPUCLK(0:3)	OUT	CPU clock outputs, powered by VDDL2. Low if CPU_STOP#=Low
40	SDRAM12	OUT	Feedback SDRAM clock output.
42	VDDL	PWR	Supply for CPU (0:3), either 2.5V or 3.3V nominal
46, 47	AGP (1:2)	OUT	Advanced Graphic Port outputs, powered by VDD4.
48	VDD4	PWR	Supply for AGP (0:2)

Notes:

- 1: Internal Pull-up Resistor of 240K to 3.3V on indicated inputs
- 2: Bidirectional input/output pins, input logic levels are latched at internal power-on-reset. Use 10Kohm resistor to program logic Hi to VDD or GND for logic low.



Mode Pin - Power Management Input Control

MODE, Pin 25 (Latched Input)	Pin 17	Pin 18	Pin 20	Pin 21
0	CPU_STOP# (INPUT)	PCI_STOP# (INPUT)	AGP_STOP# (INPUT)	PD# (INPUT)
1	SDRAM 11 (OUTPUT)	SDRAM 10 (OUTPUT)	SDRAM 9 (OUTPUT)	SDRAM 8 (OUTPUT)

Power Management Functionality

AGP_STOP#	CPU_STOP#	PCI_STOP#	AGP, CPUCLK Outputs	PCICLK (0:5)	PCICLK_F, REF, 48MHz and SDRAM	Crystal OSC	VCO	AGP(1:2)
1	0	1	Stopped Low	Running	Running	Running	Running	Running
1	1	1	Running	Running	Running	Running	Running	Running
1	1	0	Running	Stopped Low	Running	Running	Running	Running
0	1	1	Running	Running	Running	Running	Running	Stopped Low

CPU 3.3#_2.5V Buffer selector for CPUCLK drivers.

CPU3.3#_2.5 Input level (Latched Data)	Buffer Selected for operation at:
1	2.5V VDD
0	3.3V VDD

Functionality

V_{DD1,2,3,4} = 3.3V±5%, V_{DDL} = 2.5V±5% or 3.3±5%, TA=0 to 70°C
 Crystal (X1, X2) = 14.31818MHz

FS2	FS1	FS0	CPU, SDRAM (MHz)	PCI (MHz)	AGP (MHz)	REF, IOAPIC (MHz)
1	1	1	100	33.3	66.6	14.318
1	1	0	95.25	31.75	63.5	14.318
1	0	1	83.3	33.3	66.6	14.318
1	0	0	75	30	60	14.318
0	1	1	75	37.5	75	14.318
0	1	0	68.5	34.25	68.5	14.318
0	0	1	66.8	33.4	66.8	14.318
0	0	0	90	30	60	14.318



General I²C serial interface information

The information in this section assumes familiarity with I²C programming. For more information, contact ICS for an I²C programming application note.

How to Write:

- Controller (host) sends a start bit.
- Controller (host) sends the write address D2_(H)
- ICS clock will **acknowledge**
- Controller (host) sends a dummy command code
- ICS clock will **acknowledge**
- Controller (host) sends a dummy byte count
- ICS clock will **acknowledge**
- Controller (host) starts sending first byte (Byte 0) through byte 5
- ICS clock will **acknowledge** each byte *one at a time*.
- Controller (host) sends a Stop bit

How to Write:	
Controller (Host)	ICS (Slave/Receiver)
Start Bit	
Address D2 _(H)	
	ACK
Dummy Command Code	
	ACK
Dummy Byte Count	
	ACK
Byte 0	
	ACK
Byte 1	
	ACK
Byte 2	
	ACK
Byte 3	
	ACK
Byte 4	
	ACK
Byte 5	
	ACK
Stop Bit	

How to Read:

- Controller (host) will send start bit.
- Controller (host) sends the read address D3_(H)
- ICS clock will **acknowledge**
- ICS clock will send the **byte count**
- Controller (host) acknowledges
- ICS clock sends first byte (**Byte 0**) through **byte 5**
- Controller (host) will need to acknowledge each byte
- Controller (host) will send a stop bit

How to Read:	
Controller (Host)	ICS (Slave/Receiver)
Start Bit	
Address D3 _(H)	
	ACK
	Byte Count
ACK	
	Byte 0
ACK	
	Byte 1
ACK	
	Byte 2
ACK	
	Byte 3
ACK	
	Byte 4
ACK	
	Byte 5
ACK	
Stop Bit	

Notes:

1. The ICS clock generator is a slave/receiver, I²C component. It can read back the data stored in the latches for verification. **Read-Back will support Intel PIIX4 "Block-Read" protocol.**
2. The data transfer rate supported by this clock generator is 100K bits/sec or less (standard mode)
3. The input is operating at 3.3V logic levels.
4. The data byte format is 8 bit bytes.
5. To simplify the clock generator I²C interface, the protocol is set to use only "**Block-Writes**" from the controller. The bytes must be accessed in sequential order from lowest to highest byte with the ability to stop after any complete byte has been transferred. The Command code and Byte count shown above must be sent, but the data is ignored for those two bytes. The data is loaded until a Stop sequence is issued.
6. At power-on, all registers are set to a default condition, as shown.



Serial Configuration Command Bitmap

Byte0: Functionality and Frequency Select Register (default = 0)

Bit	Description	PWD			
Bit 7	Must be 0 for normal operation	0			
	0 - $\pm 0.25\%$ Spread Spectrum Modulation 1 - $\pm 0.6\%$ Spread Spectrum Modulation				
Bit 6:4	Bit6 Bit5 Bit4	CPU Clock	PCI	AGP	Note1
	111	100	33.3	66.6	
	110	95.25	31.75	63.5	
	101	83.3	33.3	66.6	
	100	75	30	60	
	011	75	37.5	75	
	010	68.5	34.25	68.5	
	001	66.8	33.4	66.8	
000	90	30	60		
Bit 3	0 - Frequency is selected by hardware select, Latched Inputs 1 - Frequency is selected by Bit 6:4 (above)	0			
	Must be 0 for normal operation				
Bit 2	0 - Spread Spectrum center spread type. 1 - Spread Spectrum down spread type.	0			
	Must be 0 for normal operation				
Bit 1	0 - Normal 1 - Spread Spectrum Enabled	0			
	0 - Running 1 - Tristate all outputs				
Bit 0		0			

Note 1. Default at Power-up will be for latched logic inputs to define frequency. Bits 4, 5, 6 are default to 000, and if bit 3 is written to a 1 to use Bits 6:4, then these should be defined to desired frequency at same write cycle.

Note: PWD = Power-Up Default

I²C is a trademark of Philips Corporation

Byte 1: CPU, Active/Inactive Register
(1 = enable, 0 = disable)

Bit	Pin #	PWD	Description
Bit 7	-	1	(Reserved)
Bit 6	-	1	(Reserved)
Bit 5	-	1	(Reserved)
Bit 4	40	1	SDRAM12 (Act/Inact)
Bit 3	-	1	(Reserved)
Bit 2	41	1	CPUCLK2 (Act/Inact)
Bit 1	43	1	CPUCLK1 (Act/Inact)
Bit 0	44	1	CPUCLK0 (Act/Inact)

Notes:

- Inactive means outputs are held LOW and are disabled from switching.

Byte 2: PCI Active/Inactive Register
(1 = enable, 0 = disable)

Bit	Pin #	PWD	Description
Bit 7	-	1	(Reserved)
Bit 6	7	1	PCICLK_F (Act/Inact)
Bit 5	-	1	(Reserved)
Bit 4	13	1	PCICLK4 (Act/Inact)
Bit 3	12	1	PCICLK3 (Act/Inact)
Bit 2	11	1	PCICLK2 (Act/Inact)
Bit 1	10	1	PCICLK1 (Act/Inact)
Bit 0	8	1	PCICLK0(Act/Inact)

Notes:

- Inactive means outputs are held LOW and are disabled from switching.



Byte 3: SDRAM Active/Inactive Register (1 = enable, 0 = disable)

Bit	Pin #	PWD	Description
Bit 7	28	1	SDRAM7 (Act/Inact)
Bit 6	29	1	SDRAM6 (Act/Inact)
Bit 5	31	1	SDRAM5 (Act/Inact)
Bit 4	32	1	SDRAM4 (Act/Inact)
Bit 3	34	1	SDRAM3 (Act/Inact)
Bit 2	35	1	SDRAM2 (Act/Inact)
Bit 1	37	1	SDRAM1 (Act/Inact)
Bit 0	38	1	SDRAM0 (Act/Inact)

Notes:

1. Inactive means outputs are held LOW and are disabled from switching.

Byte 5: Peripheral Active/Inactive Register (1 = enable, 0 = disable)

Bit	Pin #	PWD	Description
Bit 7	-	1	(Reserved)
Bit 6	-	1	(Reserved)
Bit 5	-	1	(Reserved)
Bit 4	47	1	AGP1 (Act/Inact)
Bit 3	-	1	(Reserved)
Bit 2	-	1	(Reserved)
Bit 1	46	1	AGP2 (Act/Inact)
Bit 0	2	1	REF0 (Act/Inact)

Notes:

1. Inactive means outputs are held LOW and are disabled from switching.

Byte 4: SDRAM Active/Inactive Register (1 = enable, 0 = disable)

Bit	Pin #	PWD	Description
Bit 7	25	1	AGP0 (Active/Inactive)
Bit 6	-	1	(Reserved)
Bit 5	-	1	(Reserved)
Bit 4	-	1	(Reserved)
Bit 3	17	1	SDRAM11 (Act/Inact) (Desktop Mode Only)
Bit 2	18	1	SDRAM10 (Act/Inact) (Desktop Mode Only)
Bit 1	20	1	SDRAM9 (Act/Inact)
Bit 0	21	1	SDRAM8 (Act/Inact)

Notes:

1. Inactive means outputs are held LOW and are disabled from switching.

Byte 6: Optional Register for Possible Future Requirements

Bit	Pin #	PWD	Description
Bit 7	-	1	(Reserved)
Bit 6	-	1	(Reserved)
Bit 5	-	1	(Reserved)
Bit 4	-	1	(Reserved)
Bit 3	-	1	(Reserved)
Bit 2	-	1	(Reserved)
Bit 1	-	1	(Reserved)
Bit 0	-	1	(Reserved)

Notes:

1. Byte 6 is reserved by Integrated Circuit Systems for future applications.



CPU_STOP# Timing Diagram

CPU_STOP# is an asynchronous input to the clock synthesizer. It is used to turn off the CPU clocks for low power operation. CPU_STOP# is synchronized by the ICS9148-82. The minimum that the CPU clock is enabled (CPU_STOP# high pulse) is 100 CPU clocks. All other clocks will continue to run while the CPU clocks are disabled. The CPU clocks will always be stopped in a low state and start in such a manner that guarantees the high pulse width is a full pulse. CPU clock on latency is less than 4 CPU clocks and CPU clock off latency is less than 4 CPU clocks.

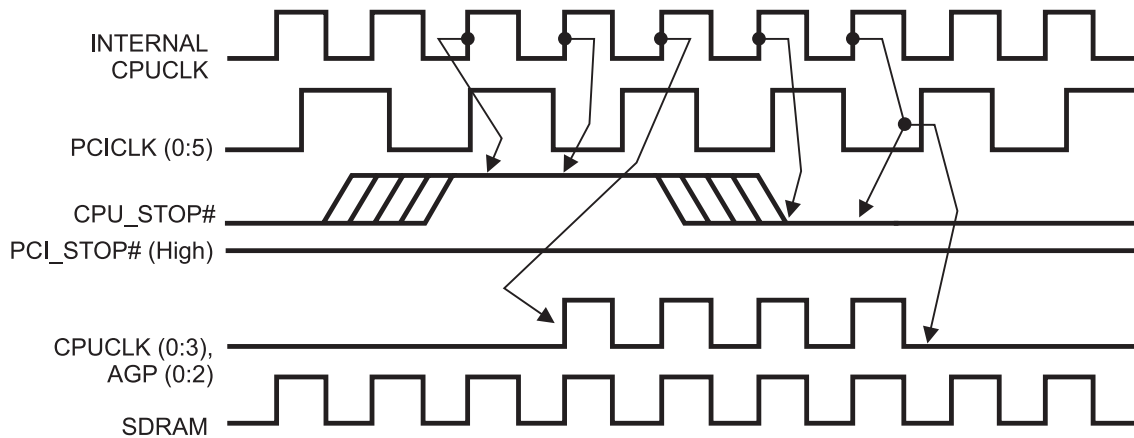

Notes:

1. All timing is referenced to the internal CPU clock.
2. CPU_STOP# is an asynchronous input and metastable conditions may exist. This signal is synchronized to the CPU clocks inside the ICS9148-82.
3. All other clocks continue to run undisturbed. (including SDRAM outputs).



PCI_STOP# Timing Diagram

PCI_STOP# is an asynchronous input to the ICS9148-82. It is used to turn off the PCICLK (0:5) clocks for low power operation. PCI_STOP# is synchronized by the ICS9148-82 internally. The minimum that the PCICLK (0:5) clocks are enabled (PCI_STOP# high pulse) is at least 10 PCICLK (0:5) clocks. PCICLK (0:5) clocks are stopped in a low state and started with a full high pulse width guaranteed. PCICLK (0:5) clock on latency cycles are only one rising PCICLK clock off latency is one PCICLK clock.

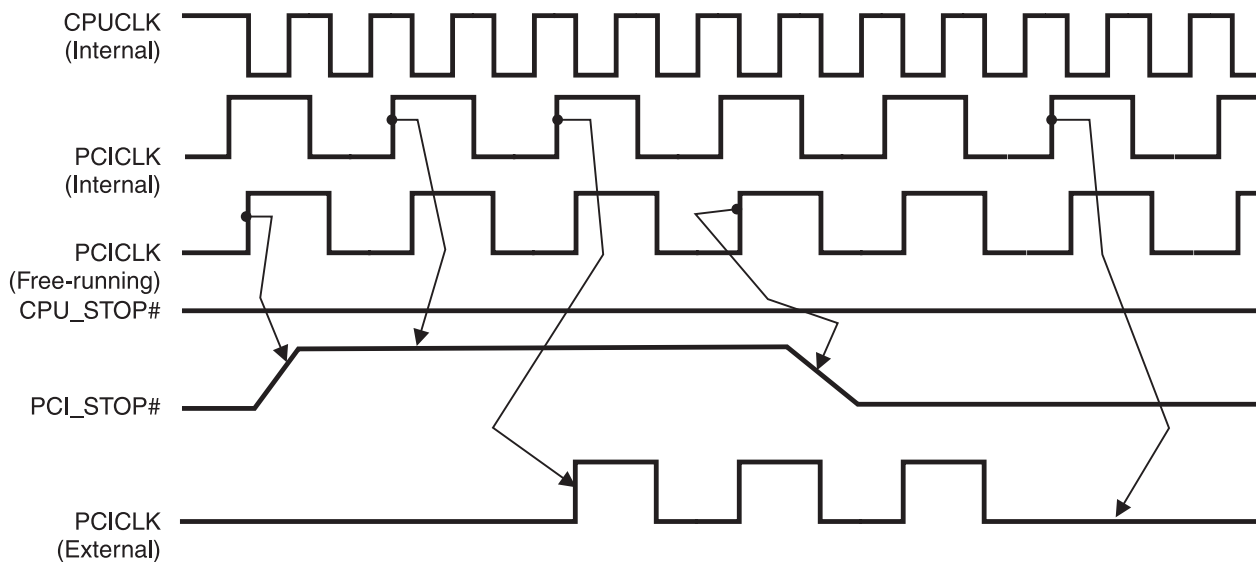

Notes:

1. All timing is referenced to the Internal CPUCLK (defined as inside the ICS9148 device.)
2. PCI_STOP# is an asynchronous input, and metastable conditions may exist. This signal is required to be synchronized inside the ICS9148.
3. All other clocks continue to run undisturbed.
4. CPU_STOP# is shown in a high (true) state.



Shared Pin Operation - Input/Output Pins

Pins 2, 7, 8, 25 & 26 on the **ICS9148-82** serve as dual signal functions to the device. During initial power-up, they act as input pins. The logic level (voltage) that is present on these pins at this time is read and stored into a 4-bit internal data latch. At the end of Power-On reset, (see AC characteristics for timing values), the device changes the mode of operations for these pins to an output function. In this mode the pins produce the specified buffered clocks to external loads.

To program (load) the internal configuration register for these pins, a resistor is connected to either the VDD (logic 1) power supply or the GND (logic 0) voltage potential. A 10 Kilohm(10K) resistor is used to provide both the solid CMOS programming voltage needed during the power-up programming period and to provide an insignificant load on the output clock during the subsequent operating period.

Figs. 1 and 2 show the recommended means of implementing this function. In Fig. 1 either one of the resistors is loaded onto the board (selective stuffing) to configure the device's internal logic. Figs. 2a and b provide a single resistor loading option where either solder spot tabs or a physical jumper header may be used.

These figures illustrate the optimal PCB physical layout options. These configuration resistors are of such a large ohmic value that they do not effect the low impedance clock signals. The layouts have been optimized to provide as little impedance transition to the clock signal as possible, as it passes through the programming resistor pad(s).

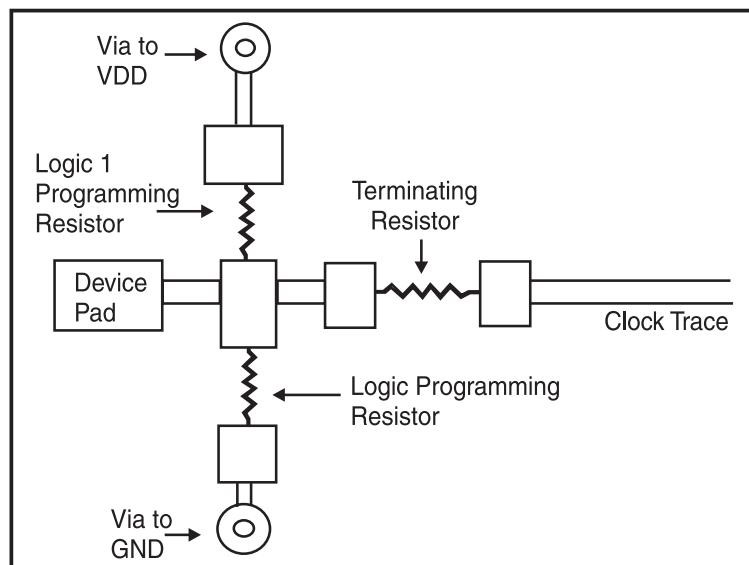

Fig. 1

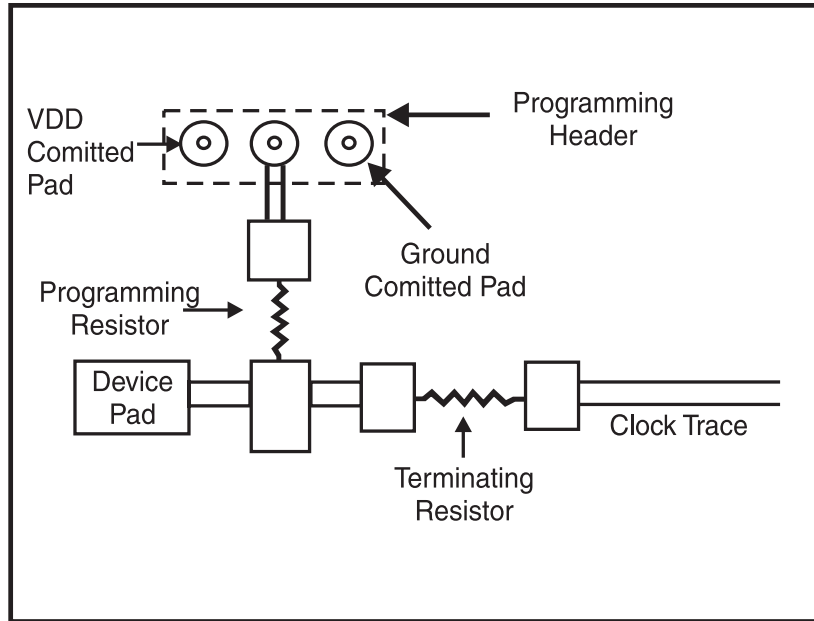

Fig. 2a

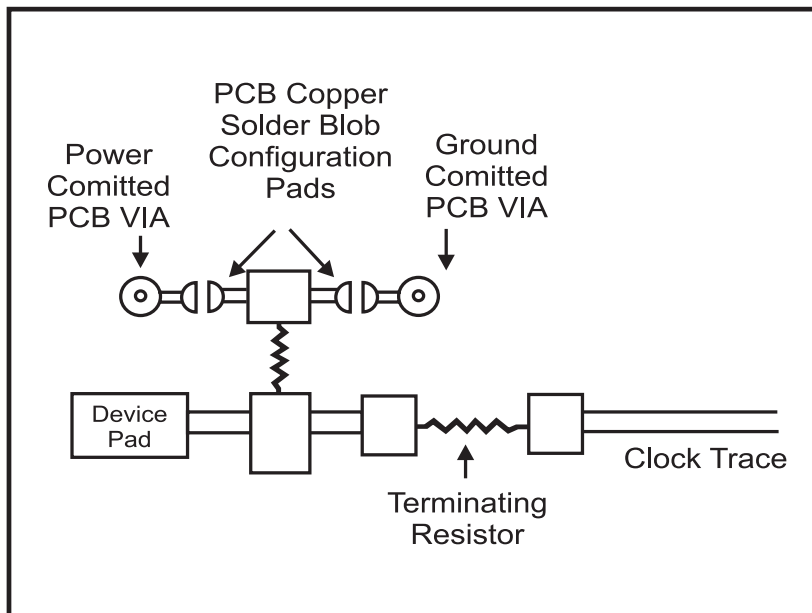

Fig. 2b



Absolute Maximum Ratings

Supply Voltage 7.0 V
 Logic Inputs GND–0.5 V to V_{DD}+0.5 V
 Ambient Operating Temperature 0°C to +70°C
 Storage Temperature –65°C to +150°C

Stresses above those listed under *Absolute Maximum Ratings* may cause permanent damage to the device. These ratings are stress specifications only and functional operation of the device at these or any other conditions above those listed in the operational sections of the specifications is not implied. Exposure to absolute maximum rating conditions for extended periods may affect product reliability.

Electrical Characteristics - Input/Supply/Common Output Parameters

T_A = 0 - 70° C; Supply Voltage V_{DD}, V_{DDL} = 3.3 V +/-5% (unless otherwise stated)

PARAMETER	SYMBOL	CONDITIONS	MIN	TYP	MAX	UNITS
Input High Voltage	V _{IH}		2		V _{DD} +0.3	V
Input Low Voltage	V _{IL}		V _{SS} -0.3		0.8	V
Input High Current	I _{IH}	V _{IN} = V _{DD}		0.1	5	μA
Input Low Current	I _{IL1}	V _{IN} = 0 V; Inputs with no pull-up resistors	-5	2.0		μA
Input Low Current	I _{IL2}	V _{IN} = 0 V; Inputs with pull-up resistors	-200	-100		μA
Operating Supply Current	I _{DD3.3OP66}	C _L = 0 pF; Select @ 66.8MHz		112	160	mA
	I _{DD3.3OP100}	C _L = 0 pF; Select @ 100MHz		141		
Input frequency	F _i	V _{DD} = 3.3 V;	12	14.318	16	MHz
Input Capacitance ¹	C _{IN}	Logic Inputs			5	pF
	C _{INX}	X1 & X2 pins	27	36	45	pF
Transition Time ¹	T _{Trans}	To first crossing of target Freq.		0.65	2	ms
Settling Time ¹	T _S	From first crossing to 1% of target Freq.		0.36	3	ms
Clk Stabilization ¹	T _{STAB}	From V _{DD} = 3.3 V to 1% target Freq.		< 2	2	ms
Skew ¹	T _{CPU-PCI1}	V _T =1.5 V; V _{TL} =1.25 V; f=66/100 MHz	1	2.45	4	ns
	T _{CPU-PCI1}	V _T =1.5 V; V _{TL} =1.25 V; f=83/75 MHz	1	3.8	4	ns
	T _{AGP-PCI1}	V _T = 1.5 V; AGP leads		390	500	ps

¹Guaranteed by design, not 100% tested in production.

Electrical Characteristics - Input/Supply/Common Output Parameters

T_A = 0 - 70° C; Supply Voltage V_{DD} = 3.3 V +/-5%, V_{DDL} = 2.5 V +/-5% (unless otherwise stated)

PARAMETER	SYMBOL	CONDITIONS	MIN	TYP	MAX	UNITS
Operating Supply Current	I _{DD2.5OP66}	C _L = 0 pF; Select @ 66.8 MHz		14	20	mA
	I _{DD2.5OP100}	C _L = 0 pF; Select @ 100 MHz		18	20	
Skew ¹	T _{CPU-PCI1}	V _T =1.5 V; V _{TL} =1.25 V; f=66/100 MHz	1	2.45	4	ns
	T _{CPU-PCI1}	V _T =1.5 V; V _{TL} =1.25 V; f=83/75 MHz	1	3.8	4	ns
	T _{AGP-PCI1}	V _T =1.5 V; AGP Leads		220	500	ns

¹Guaranteed by design, not 100% tested in production.



Electrical Characteristics - CPUCLK

$T_A = 0 - 70^\circ \text{C}$; $V_{DD} = 3.3 \text{ V} \pm 5\%$, $V_{DDL} = 2.5 \text{ V} \pm 5\%$; $C_L = 20 \text{ pF}$ (unless otherwise stated)

PARAMETER	SYMBOL	CONDITIONS	MIN	TYP	MAX	UNITS
Output High Voltage	V_{OH2B}	$I_{OH} = -8.0 \text{ mA}$	2	2.2		V
Output Low Voltage	V_{OL2B}	$I_{OL} = 12 \text{ mA}$		0.3	0.4	V
Output High Current	I_{OH2B}	$V_{OH} = 1.7 \text{ V}$		-20	-16	mA
Output Low Current	I_{OL2B}	$V_{OL} = 0.7 \text{ V}$	19	26		mA
Rise Time	t_{r2B}^1	$V_{OL} = 0.4 \text{ V}$, $V_{OH} = 2.0 \text{ V}$		1.5	1.8	ns
Fall Time	t_{f2B}^1	$V_{OH} = 2.0 \text{ V}$, $V_{OL} = 0.4 \text{ V}$		1.6	1.8	ns
Duty Cycle	d_{t2B}^1	$V_T = 1.25 \text{ V}$	40	50	55	%
Skew	t_{sk2B}^1	$V_T = 1.25 \text{ V}$		60	250	ps
Jitter, Single Edge Displacement	$t_{j\text{srd}2B}^1$	$V_T = 1.25 \text{ V}$		200	250	ps
Jitter, One Sigma	$t_{j1\sigma 2B}^1$	$V_T = 1.25 \text{ V}$		31	150	ps
Jitter, Absolute	$t_{j\text{abs}2B}^1$	$V_T = 1.25 \text{ V}$	-250	160	+250	ps

¹Guaranteed by design, not 100% tested in production.

Electrical Characteristics - PCICLK

$T_A = 0 - 70^\circ \text{C}$; $V_{DD} = 3.3 \text{ V} \pm 5\%$, $V_{DDL} = 2.5 \text{ V} \pm 5\%$; $C_L = 30 \text{ pF}$ (unless otherwise stated)

PARAMETER	SYMBOL	CONDITIONS	MIN	TYP	MAX	UNITS
Output High Voltage	V_{OH1}	$I_{OH} = -28 \text{ mA}$	2.4	3		V
Output Low Voltage	V_{OL1}	$I_{OL} = 23 \text{ mA}$		0.34	0.4	V
Output High Current	I_{OH1}	$V_{OH} = 2.0 \text{ V}$		-60	-40	mA
Output Low Current	I_{OL1}	$V_{OL} = 0.8 \text{ V}$	41	53		mA
Rise Time ¹	t_{r1}	$V_{OL} = 0.4 \text{ V}$, $V_{OH} = 2.4 \text{ V}$		1.7	2	ns
Fall Time ¹	t_{f1}	$V_{OH} = 2.4 \text{ V}$, $V_{OL} = 0.4 \text{ V}$		1.5	2	ns
Duty Cycle ¹	d_{t1}	$V_T = 1.5 \text{ V}$	45	51	55	%
Skew ¹	t_{sk1}	$V_T = 1.5 \text{ V}$		60	250	ps
Jitter, One Sigma ¹	$t_{j1\sigma 1a}$	$V_T = 1.5 \text{ V}$, Synchronous		28	150	ps
	$t_{j1\sigma 1b}$	$V_T = 1.5 \text{ V}$, Asynchronous		98	250	ps
Jitter, Absolute ¹	$t_{j\text{abs}1a}$	$V_T = 1.5 \text{ V}$, Synchronous	-250	107	250	ps
	$t_{j\text{abs}1b}$	$V_T = 1.5 \text{ V}$, Asynchronous	-650	200	650	ps

¹Guaranteed by design, not 100% tested in production.



Electrical Characteristics - SDRAM

T_A = 0 - 70° C; V_{DD} = 3.3 V +/-5%, V_{DDL} = 2.5 V +/-5%; C_L = 30 pF (unless otherwise stated)

PARAMETER	SYMBOL	CONDITIONS	MIN	TYP	MAX	UNITS
Output High Voltage	V _{OH3}	I _{OH} = -28 mA	2.4	2.8		V
Output Low Voltage	V _{OL3}	I _{OL} = 23 mA		0.35	0.4	V
Output High Current	I _{OH3}	V _{OH} = 2.0 V		-63	-40	mA
Output Low Current	I _{OL3}	V _{OL} = 0.8 V	41	51		mA
Rise Time	T _{r3} ¹	V _{OL} = 0.4 V, V _{OH} = 2.4 V		1.5	2	ns
Fall Time	T _{f3} ¹	V _{OH} = 2.4 V, V _{OL} = 0.4 V		1.6	2	ns
Duty Cycle	D _{t3} ¹	V _T = 1.5 V	45	54	55	%
Skew ¹	T _{sk1}	V _T = 1.5 V		200	500	ps
Propagation Delay	T _{prop}	V _T = 1.5 V		4	6	ns

¹Guaranteed by design, not 100% tested in production.

Electrical Characteristics - AGP

T_A = 0 - 70° C; V_{DD} = 3.3 V +/-5%, V_{DDL} = 2.5 V +/-5%; C_L = 30 pF (unless otherwise stated)

PARAMETER	SYMBOL	CONDITIONS	MIN	TYP	MAX	UNITS
Output High Voltage	V _{OH1}	I _{OH} = -28 mA	2.4	3		V
Output Low Voltage	V _{OL1}	I _{OL} = 23 mA		0.2	0.4	V
Output High Current	I _{OH1}	V _{OH} = 2.0 V		-60	-40	mA
Output Low Current	I _{OL1}	V _{OL} = 0.8 V	41	50		mA
Rise Time ¹	t _{r1}	V _{OL} = 0.4 V, V _{OH} = 2.4 V		1.1	2	ns
Fall Time ¹	t _{f1}	V _{OH} = 2.4 V, V _{OL} = 0.4 V		1.3	2	ns
Duty Cycle ¹	d _{t1}	V _T = 1.4 V, CPU @ 100MHz	45	50	55	%
Skew ¹	t _{sk1}	V _T = 1.5 V		130	250	ps
Jitter, One Sigma ¹	t _{j1σ1a}	V _T = 1.5 V, Synchronous		2	3	%
Jitter, Absolute ¹	t _{jabs1a}	V _T = 1.5 V, Synchronous	-5	2.5	5	%
	t _{jabs1b}	V _T = 1.5 V, Asynchronous	-6	4.5	6	%

¹Guaranteed by design, not 100% tested in production.



Electrical Characteristics - REF0

T_A = 0 - 70° C; V_{DD} = 3.3 V +/-5%, V_{DDL} = 2.5 V +/-5%; C_L = 20 pF (unless otherwise stated)

PARAMETER	SYMBOL	CONDITIONS	MIN	TYP	MAX	UNITS
Output High Voltage	V _{OH5}	I _{OH} = -16 mA	2.4	2.6		V
Output Low Voltage	V _{OL5}	I _{OL} = 9 mA		0.26	0.4	V
Output High Current	I _{OH5}	V _{OH} = 2.0 V		-32	-22	mA
Output Low Current	I _{OL5}	V _{OL} = 0.8 V	16	27		mA
Rise Time ¹	t _{r5}	V _{OL} = 0.4 V, V _{OH} = 2.4 V		1.3	4	ns
Fall Time ¹	t _{f5}	V _{OH} = 2.4 V, V _{OL} = 0.4 V		2	4	ns
Duty Cycle ¹	d _{t5}	V _T = 1.5 V	45	55	57	%
Jitter, One Sigma ¹	t _{jl5}	V _T = 1.5 V		0.22	3	%
Jitter, Absolute ¹	t _{jabs5}	V _T = 1.5 V	-5	0.63	5	%

¹Guaranteed by design, not 100% tested in production.



General Layout Precautions:

- 1) Use a ground plane on the top layer of the PCB in all areas not used by traces.
- 2) Make all power traces and vias as wide as possible to lower inductance.

Notes:

- 1 All clock outputs should have series terminating resistor. Not shown in all places to improve readability of diagram
- 2 Optional EMI capacitor should be used on all CPU, SDRAM, and PCI outputs.
- 3 Optional crystal load capacitors are recommended.

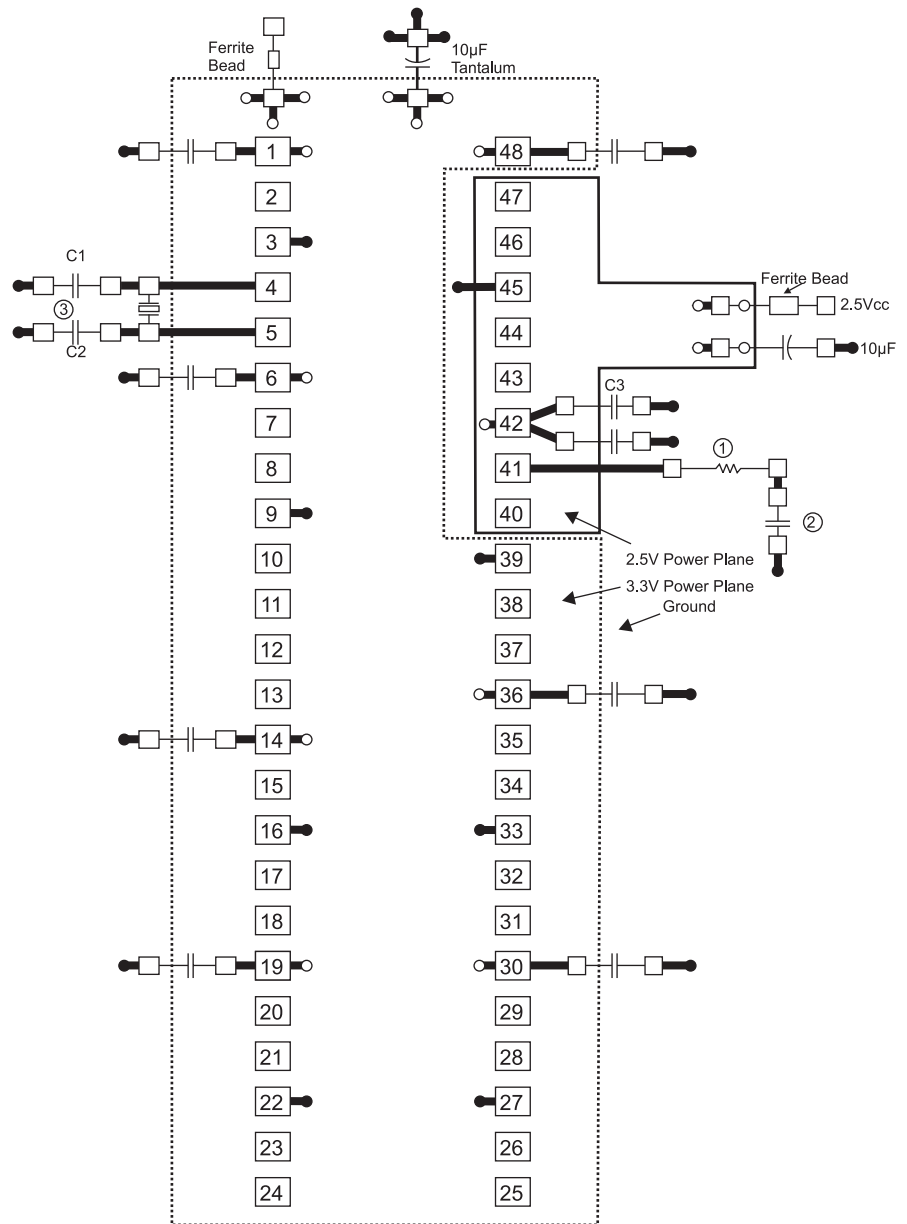

- = Ground Plane Connection
- = Power Plane Connection
- = Solder Pads

Capacitor Values:

C1, C2 : Crystal load values determined by user

C3 : 100pF ceramic

All unmarked capacitors are 0.01µF ceramic



ICS9148-82

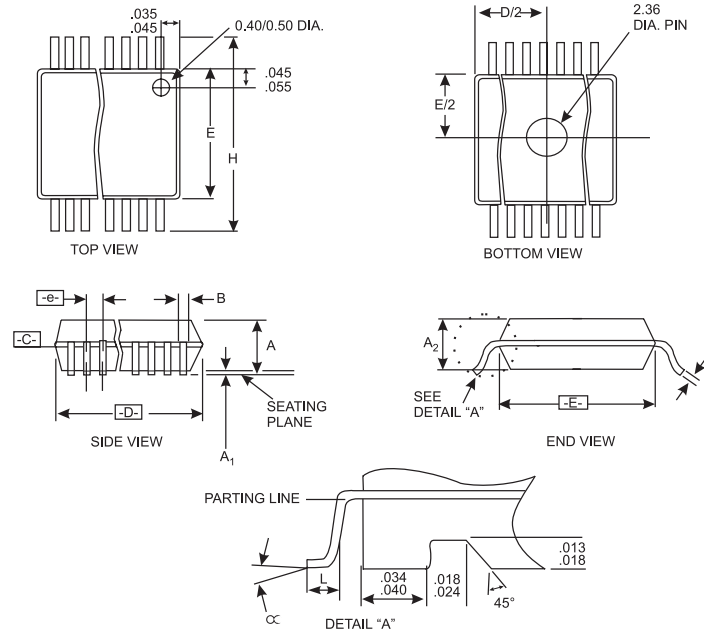

SYMBOL	COMMON DIMENSIONS			VARIATIONS	D			N
	MIN.	NOM.	MAX.		MIN.	NOM.	MAX.	
A	.095	.101	.110	AC	.620	.625	.630	48
A1	.008	.012	.016	SSOP Package				
A2	.088	.090	.092					
B	.008	.010	.0135					
C	.005	-	.010					
D	See Variations							
E	.292	.296	.299					
e	0.025 BSC							
H	.400	.406	.410					
h	.010	.013	.016					
L	.024	.032	.040					
N	See Variations							
∞	0°	5°	8°					
X	.085	.093	.100					

Ordering Information

ICS9148yF-82

Example:

ICS XXXX y F - PPP

