

Bulletin I2110 rev. B 04/99

International **IOR** Rectifier

QUIETIR Series 80EPF..

FAST SOFT RECOVERY RECTIFIER DIODE

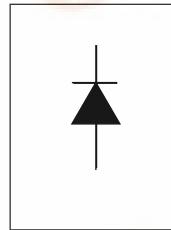

$V_F < 1.1V @ 40A$
 $t_{rr} = 70ns$
 $V_{RRM} 200 \text{ to } 600V$

Description/Features

The 80EPF.. fast soft recovery **QUIETIR** rectifier series has been optimized for combined short reverse recovery time and low forward voltage drop. The glass passivation ensures stable reliable operation in the most severe temperature and power cycling conditions.

Typical applications are both:

- output rectification and freewheeling in inverters, choppers and converters
- and input rectifications where severe restrictions on conducted EMI should be met.

Major Ratings and Characteristics

Characteristics	80EPF..	Units
$I_{F(AV)}$ Sinusoidal waveform	80	A
V_{RRM} range	200 to 600	V
I_{FSM}	1000	A
V_F @ 40A, $T_J = 25^\circ C$	1.1	V
t_{rr} @ 1A, -100A/ μs	70	ns
T_J range	-40 to 150	$^\circ C$

Package Outline



80EPF.. QUIETIR Series

Bulletin I2110 rev. A 06/97

International
IOR Rectifier

Voltage Ratings

Part Number	V_{RRM} , maximum peak reverse voltage V	V_{RSM} , maximum non repetitive peak reverse voltage V	I_{RRM} 150°C mA
80EPF02	200	300	17
80EPF04	400	500	
80EPF06	600	700	

Absolute Maximum Ratings

Parameters	80EPF..	Units	Conditions
$I_{F(AV)}$ Max. Average Forward Current	80	A	@ $T_C = 95^\circ\text{C}$, 180° conduction half sine wave
I_{FSM} Max. Peak One Cycle Non-Repetitive Surge Current	850	A	10ms Sine pulse, rated V_{RRM} applied
	1000		10ms Sine pulse, no voltage reapplied
I^2t Max. I^2t for fusing	3610	A^2s	10ms Sine pulse, rated V_{RRM} applied
	5100		10ms Sine pulse, no voltage reapplied
$I^2\sqrt{t}$ Max. $I^2\sqrt{t}$ for fusing	51000	$A^2\sqrt{s}$	$t = 0.1$ to 10ms, no voltage reapplied

Electrical Specifications

Parameters	80EPF..	Units	Conditions
V_{FM} Max. Forward Voltage Drop	1.25	V	@ 80A, $T_J = 25^\circ\text{C}$
r_t Forward slope resistance	3.5	$m\Omega$	$T_J = 125^\circ\text{C}$
$V_{F(TO)}$ Threshold voltage	0.85	V	
I_{RM} Max. Reverse Leakage Current	0.1	mA	$T_J = 25^\circ\text{C}$
	17		$T_J = 150^\circ\text{C}$

$V_R = \text{rated } V_{RRM}$

Recovery Characteristics

Parameters	80EPF..	Units	Conditions
t_{rr} Reverse Recovery Time	190	ns	$I_F @ 40\text{Apk}$ @ 25A/ μs @ 25°C
I_{rr} Reverse Recovery Current	3.4	A	
Q_{rr} Reverse Recovery Charge	0.5	μC	
S Snap Factor	0.5		

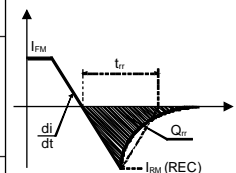

Thermal-Mechanical Specifications

Parameters		80EPF..	Units	Conditions
T_J	Max. Junction Temperature Range	-40 to 150	°C	
T_{stg}	Max. Storage Temperature Range	-40 to 150	°C	
R_{thJC}	Max. Thermal Resistance Junction to Case	0.35	°C/W	DC operation
R_{thJA}	Max. Thermal Resistance Junction to Ambient	40	°C/W	
R_{thCS}	Typical Thermal Resistance, Case to Heatsink	0.2	°C/W	Mounting surface, smooth and greased
wt	Approximate Weight	6 (0.21)	g (oz.)	
T	Mounting Torque	Min.	6 (5)	Kg-cm (lbf-in)
		Max.	12 (10)	
Case Style		TO-247AC		

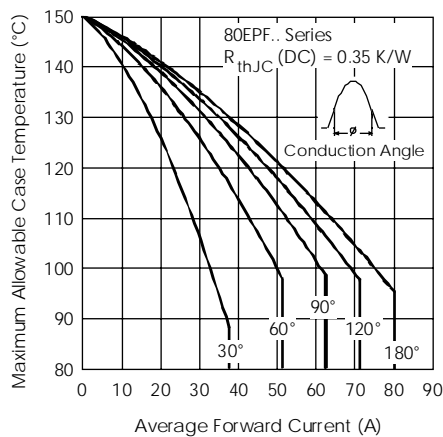

Fig. 1 - Current Rating Characteristics

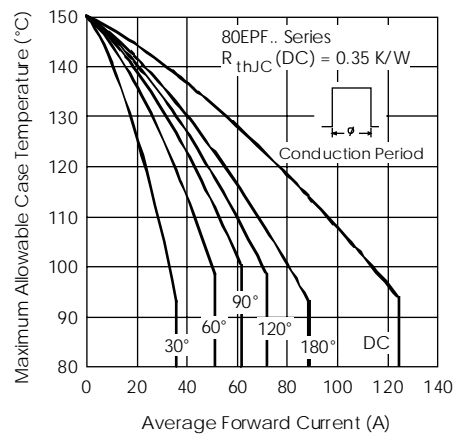

Fig. 2 - Current Rating Characteristics

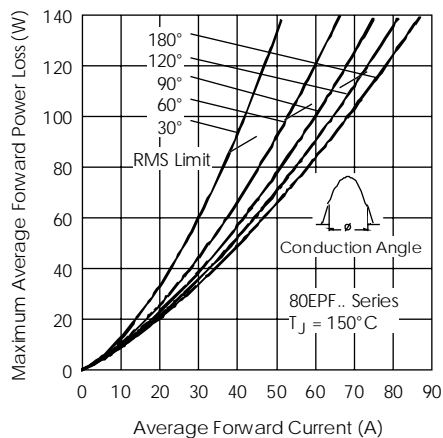

Fig. 3 - Forward Power Loss Characteristics

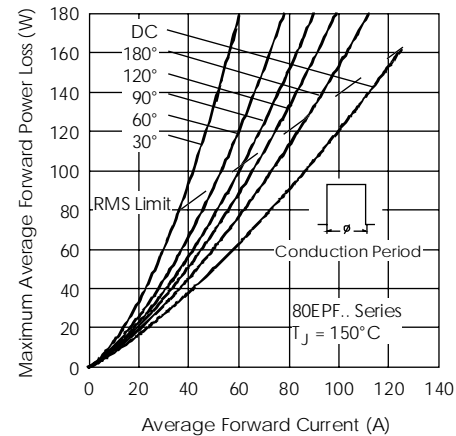

Fig. 4 - Forward Power Loss Characteristics

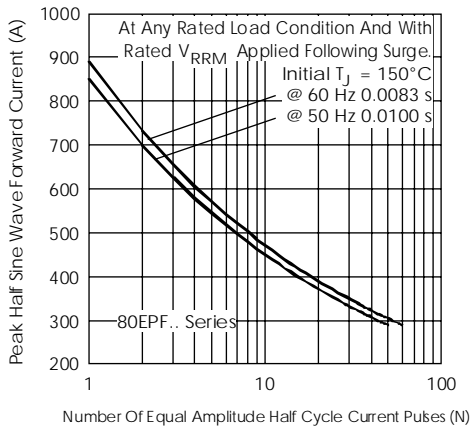

Fig. 5 - Maximum Non-Repetitive Surge Current

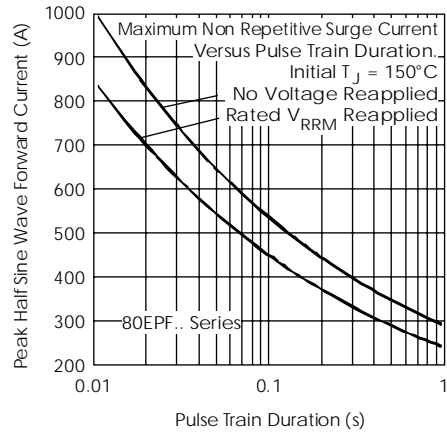

Fig. 6 - Maximum Non-Repetitive Surge Current

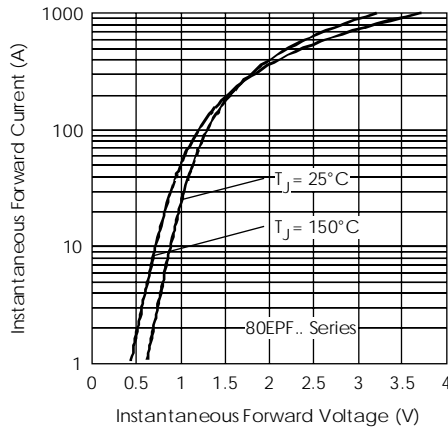

Fig. 7 - Forward Voltage Drop Characteristics

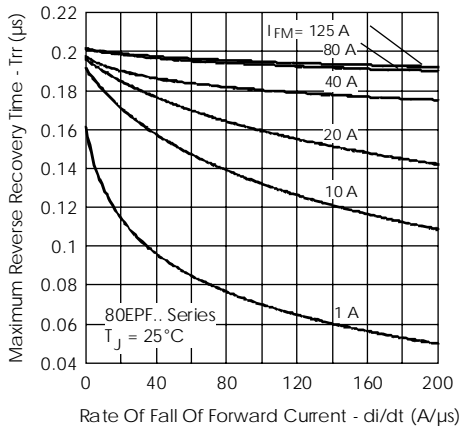

Fig. 8 - Recovery Time Characteristics, $T_J = 25^\circ\text{C}$

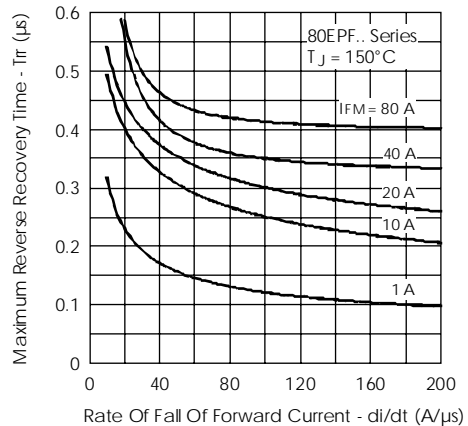

Fig. 9 - Recovery Time Characteristics, $T_J = 150^\circ\text{C}$

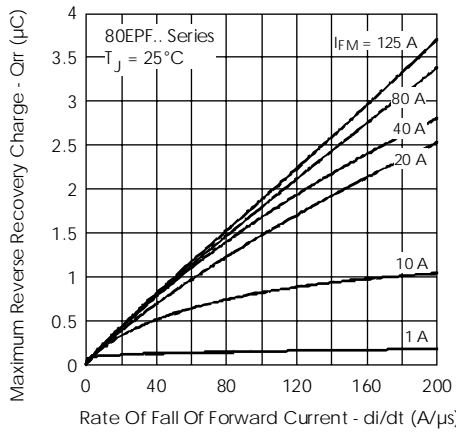

Fig. 10 - Recovery Charge Characteristics, $T_J = 25^\circ\text{C}$

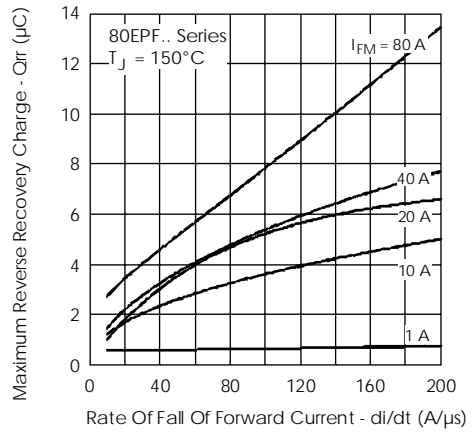

Fig. 11 - Recovery Charge Characteristics, $T_J = 150^\circ\text{C}$

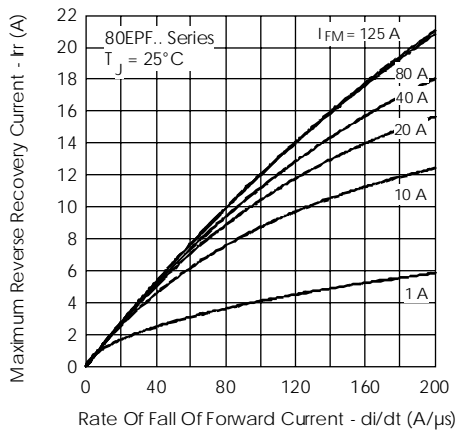

Fig. 12 - Recovery Current Characteristics, $T_J = 25^\circ\text{C}$

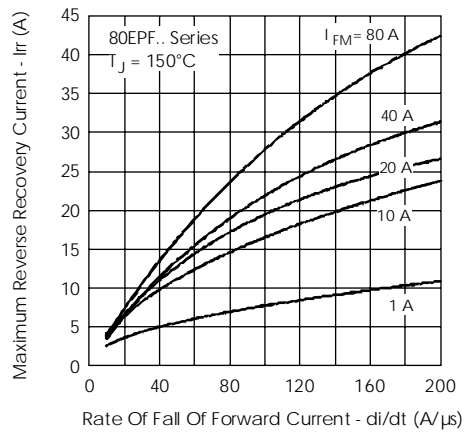

Fig. 13 - Recovery Current Characteristics, $T_J = 150^\circ\text{C}$

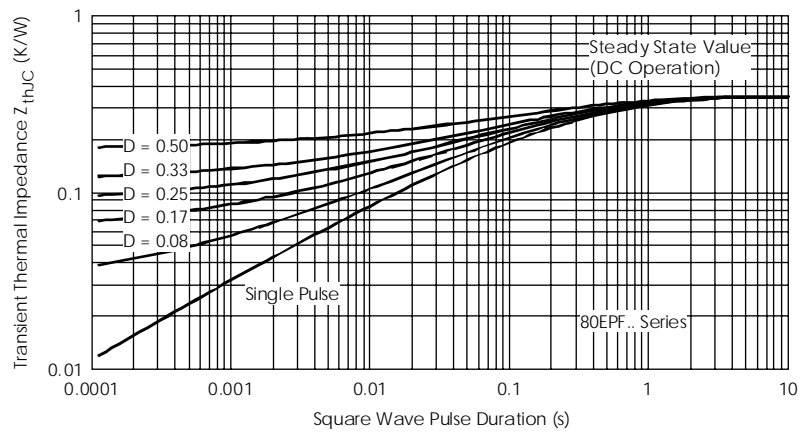
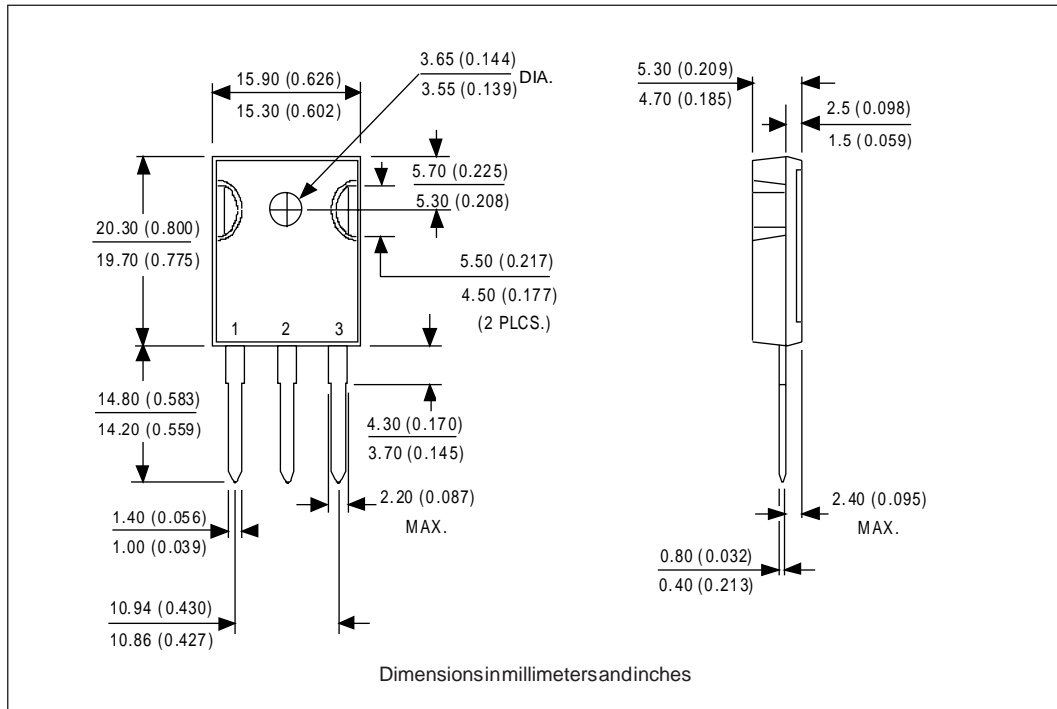

Fig. 14 - Thermal Impedance Z_{thJC} Characteristics

Outline Table



Ordering Information Table

