

MC14581B

4-Bit Arithmetic Logic Unit

The MC14581B is a CMOS 4-bit ALU capable of providing 16 functions of two Boolean variables and 16 binary arithmetic operations on two 14-bit words. The level of the mode control input determines whether the output function is logic or arithmetic. The desired logic function is selected by applying the appropriate binary word to the select inputs (S0 thru S3) with the mode control input high, while the desired arithmetic operation is selected by applying a low voltage to the mode control input, the required level to carry in, and the appropriate word to the select inputs. The word inputs and function outputs can be operated with either active high or active low data.

Carry propagate (\bar{P}) and carry generate (\bar{G}) outputs are provided to allow a full look-ahead carry scheme for fast simultaneous carry generation for the four bits in the package. Fast arithmetic operations on long words are obtainable by using the MC14582B as a second order look ahead block. An inverted ripple carry input (C_n) and a ripple carry output (C_{n+4}) are included for ripple through operation.

When the device is in the subtract mode (LHHL), comparison of two 4-bit words present at the \bar{A} and \bar{B} inputs is provided using the A = B output. It assumes a high-level state when indicating equality. Also, when the ALU is in the subtract mode the C_{n+4} output can be used to indicate relative magnitude as shown in this table:

Data Level	C_n	C_{n+4}	Magnitude
Active High	H	H	$A \leq B$
	L	H	$A < B$
	H	L	$A > B$
	L	L	$A \geq B$
Active Low	L	L	$A \leq B$
	H	L	$A < B$
	L	H	$A > B$
	H	H	$A \geq B$

- Functional and Pinout Equivalent to 74181.
- Diode Protection on All Inputs
- All Outputs Buffered
- Supply Voltage Range = 3.0 Vdc to 18 Vdc
- Capable of Driving Two Low-power TTL Loads or One Low-power Schottky TTL Load over the Rated Temperature Range

MAXIMUM RATINGS* (Voltages Referenced to V_{SS})

Symbol	Parameter	Value	Unit
V_{DD}	DC Supply Voltage	- 0.5 to + 18.0	V
V_{in}, V_{out}	Input or Output Voltage (DC or Transient)	- 0.5 to $V_{DD} + 0.5$	V
I_{in}, I_{out}	Input or Output Current (DC or Transient), per Pin	± 10	mA
P_D	Power Dissipation, per Package†	500	mW
T_{stg}	Storage Temperature	- 65 to + 150	°C
T_L	Lead Temperature (8-Second Soldering)	260	°C

* Maximum Ratings are those values beyond which damage to the device may occur.

† Temperature Derating:

Plastic "P and D/DW" Packages: - 7.0 mW/°C From 65°C To 125°C

Ceramic "L" Packages: - 12 mW/°C From 100°C To 125°C

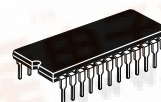

L SUFFIX
 CERAMIC
 CASE 623

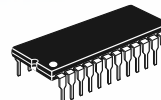

P SUFFIX
 PLASTIC
 CASE 709



DW SUFFIX
 SOIC
 CASE 751E

ORDERING INFORMATION

MC14XXXBCP Plastic
 MC14XXXBCL Ceramic
 MC14XXXBDW SOIC

$T_A = -55^\circ$ to 125°C for all packages.

PIN ASSIGNMENT

$\bar{B}0$	1	24	V_{DD}
$\bar{A}0$	2	23	$\bar{A}1$
S3	3	22	$\bar{B}1$
S2	4	21	$\bar{A}2$
S1	5	20	$\bar{B}2$
S0	6	19	$\bar{A}3$
C_n	7	18	$\bar{B}3$
MC	8	17	\bar{G}
$\bar{F}0$	9	16	C_{n+4}
$\bar{F}1$	10	15	\bar{P}
$\bar{F}2$	11	14	A = B
V_{SS}	12	13	$\bar{F}3$

ELECTRICAL CHARACTERISTICS (Voltages Referenced to V_{SS})

Characteristic	Symbol	V_{DD} Vdc	- 55 °C		25 °C			125 °C		Unit	
			Min	Max	Min	Typ #	Max	Min	Max		
Output Voltage $V_{in} = V_{DD}$ or 0 $V_{in} = 0$ or V_{DD}	"0" Level V_{OL}	5.0	—	0.05	—	0	0.05	—	0.05	Vdc	
		10	—	0.05	—	0	0.05	—	0.05		
		15	—	0.05	—	0	0.05	—	0.05		
	"1" Level V_{OH}	5.0	4.95	—	4.95	5.0	—	4.95	—		Vdc
		10	9.95	—	9.95	10	—	9.95	—		
		15	14.95	—	14.95	15	—	14.95	—		
Input Voltage ($V_O = 4.5$ or 0.5 Vdc) ($V_O = 9.0$ or 1.0 Vdc) ($V_O = 13.5$ or 1.5 Vdc) ($V_O = 0.5$ or 4.5 Vdc) ($V_O = 1.0$ or 9.0 Vdc) ($V_O = 1.5$ or 13.5 Vdc)	"0" Level V_{IL}	5.0	—	1.5	—	2.25	1.5	—	1.5	Vdc	
		10	—	3.0	—	4.50	3.0	—	3.0		
		15	—	4.0	—	6.75	4.0	—	4.0		
	"1" Level V_{IH}	5.0	3.5	—	3.5	2.75	—	3.5	—		Vdc
		10	7.0	—	7.0	5.50	—	7.0	—		
		15	11	—	11	8.25	—	11	—		
Output Drive Current ($V_{OH} = 2.5$ Vdc) ($V_{OH} = 4.6$ Vdc) ($V_{OH} = 9.5$ Vdc) ($V_{OH} = 13.5$ Vdc) ($V_{OL} = 0.4$ Vdc) ($V_{OL} = 0.5$ Vdc) ($V_{OL} = 1.5$ Vdc)	Source I_{OH}	5.0	- 1.2	—	- 1.0	- 1.7	—	- 0.7	—	mAdc	
		5.0	- 0.64	—	- 0.51	- 0.88	—	- 0.36	—		
		10	- 1.6	—	- 1.3	- 2.25	—	- 0.9	—		
		15	- 4.2	—	- 3.4	- 8.8	—	- 2.4	—		
	Sink I_{OL}	5.0	0.64	—	0.51	0.88	—	0.36	—		mAdc
		10	1.6	—	1.3	2.25	—	0.9	—		
15	4.2	—	3.4	8.8	—	2.4	—	—			
Input Capacitance ($V_{in} = 0$)	C_{in}	—	—	—	—	5.0	7.5	—	—	pF	
Quiescent Current (Per Package)	I_{DD}	5.0	—	5.0	—	0.005	5.0	—	150	μ Adc	
		10	—	10	—	0.010	10	—	300		
		15	—	20	—	0.015	20	—	600		
Total Supply Current**† (Dynamic plus Quiescent, Per Package) ($C_L = 50$ pF on all outputs, all buffers switching)	I_T	5.0	$I_T = (1.8 \mu\text{A/kHz}) f + I_{DD}$ $I_T = (3.7 \mu\text{A/kHz}) f + I_{DD}$ $I_T = (5.5 \mu\text{A/kHz}) f + I_{DD}$							μ Adc	

#Data labelled "Typ" is not to be used for design purposes but is intended as an indication of the IC's potential performance.

**The formulas given are for the typical characteristics only at 25 °C.

†To calculate total supply current at loads other than 50 pF:

$$I_T(C_L) = I_T(50 \text{ pF}) + (C_L - 50) Vfk$$

where: I_T is in μA (per package), C_L in pF, $V = (V_{DD} - V_{SS})$ in volts, f in kHz is input frequency, and $k = 0.008$.

This device contains protection circuitry to guard against damage due to high static voltages or electric fields. However, precautions must be taken to avoid applications of any voltage higher than maximum rated voltages to this high-impedance circuit. For proper operation, V_{in} and V_{out} should be constrained to the range $V_{SS} \leq (V_{in} \text{ or } V_{out}) \leq V_{DD}$. Unused inputs must always be tied to an appropriate logic voltage level (e.g., either V_{SS} or V_{DD}). Unused outputs must be left open.

SWITCHING CHARACTERISTICS* ($C_L = 50 \text{ pF}$, $T_A = 25^\circ\text{C}$)

Characteristic	Symbol	V _{DD}	Min	Typ #	Max	Unit
Output Rise and Fall Time $t_{TLH}, t_{THL} = (1.5 \text{ ns/pF}) C_L + 25 \text{ ns}$ $t_{TLH}, t_{THL} = (0.75 \text{ ns/pF}) C_L + 12.5 \text{ ns}$ $t_{TLH}, t_{THL} = (0.55 \text{ ns/pF}) C_L + 9.5 \text{ ns}$	t_{TLH}, t_{THL}	5.0 10 15	— — —	100 50 40	200 100 80	ns
Propagation Delay Time Sum in to Sum Out $t_{PLH}, t_{PHL} = (1.7 \text{ ns/pF}) C_L + 620 \text{ ns}$ $t_{PLH}, t_{PHL} = (0.66 \text{ ns/pF}) C_L + 217 \text{ ns}$ $t_{PLH}, t_{PHL} = (0.5 \text{ ns/pF}) C_L + 155 \text{ ns}$	t_{PLH}, t_{PHL}	5.0 10 15	— — —	705 250 180	1410 500 360	ns
Sum in to Sum Out (Logic Mode) $t_{PLH}, t_{PHL} = (1.7 \text{ ns/pF}) C_L + 520 \text{ ns}$ $t_{PLH}, t_{PHL} = (0.66 \text{ ns/pF}) C_L + 182 \text{ ns}$ $t_{PLH}, t_{PHL} = (0.5 \text{ ns/pF}) C_L + 155 \text{ ns}$	t_{PLH}, t_{PHL}	5.0 10 15	— — —	605 215 180	1210 430 360	ns
Sum in to A = B $t_{PLH}, t_{PHL} = (1.7 \text{ ns/pF}) C_L + 870 \text{ ns}$ $t_{PLH}, t_{PHL} = (0.66 \text{ ns/pF}) C_L + 297 \text{ ns}$ $t_{PLH}, t_{PHL} = (0.5 \text{ ns/pF}) C_L + 220 \text{ ns}$	t_{PLH}, t_{PHL}	5.0 10 15	— — —	955 330 245	1910 660 490	ns
Sum in to P or G $t_{PLH}, t_{PHL} = (1.7 \text{ ns/pF}) C_L + 400 \text{ ns}$ $t_{PLH}, t_{PHL} = (0.66 \text{ ns/pF}) C_L + 147 \text{ ns}$ $t_{PLH}, t_{PHL} = (0.5 \text{ ns/pF}) C_L + 105 \text{ ns}$	t_{PLH}, t_{PHL}	5.0 10 15	— — —	485 180 130	970 360 260	ns
Sum in to C _{n+4} $t_{PLH}, t_{PHL} = (1.7 \text{ ns/pF}) C_L + 530 \text{ ns}$ $t_{PLH}, t_{PHL} = (0.66 \text{ ns/pF}) C_L + 187 \text{ ns}$ $t_{PLH}, t_{PHL} = (0.5 \text{ ns/pF}) C_L + 135 \text{ ns}$	t_{PLH}	5.0 10 15	— — —	615 220 160	1230 440 360	ns
Carry in to Sum Out $t_{PLH}, t_{PHL} = (1.7 \text{ ns/pF}) C_L + 295 \text{ ns}$ $t_{PLH}, t_{PHL} = (0.66 \text{ ns/pF}) C_L + 112 \text{ ns}$ $t_{PLH}, t_{PHL} = (0.5 \text{ ns/pF}) C_L + 80 \text{ ns}$	t_{PLH}, t_{PHL}	5.0 10 15	— — —	380 145 105	760 290 210	ns
Carry in to C _{n+4} $t_{PLH}, t_{PHL} = (1.7 \text{ ns/pF}) C_L + 220 \text{ ns}$ $t_{PLH}, t_{PHL} = (0.66 \text{ ns/pF}) C_L + 87 \text{ ns}$ $t_{PLH}, t_{PHL} = (0.5 \text{ ns/pF}) C_L + 60 \text{ ns}$	t_{PLH}, t_{PHL}	5.0 10 15	— — —	305 120 85	610 240 170	ns

* The formulas given are for the typical characteristics only at 25°C.

#Data labelled "Typ" is not to be used for design purposes but is intended as an indication of the IC's potential performance.

AC TEST SETUP REFERENCE TABLE

Test	AC Paths		DC Data Inputs		Mode	Fig. 3 Waveform
	Inputs	Outputs	To V _{SS}	To V _{DD}		
Sum _{in} to Sum _{out} Delay Time	$\bar{A}0$	Any \bar{F}	Remaining \bar{A} 's C _n	All \bar{B} 's	Add	#1
Sum _{in} to \bar{P} Delay Time	$\bar{A}0$	\bar{P}	Remaining \bar{A} 's C _n	All \bar{B} 's	Add	#1
Sum _{in} to \bar{G} Delay Time	$\bar{B}0$	\bar{G}	All \bar{A} 's C _n	Remaining \bar{B} 's	Add	#1
Sum _{in} to C _{n+4} Delay Time	$\bar{B}0$	C _{n+y}	All \bar{A} 's C _n	Remaining \bar{B} 's	Add	#2
C _n to Sum _{out} Delay Time	C _n	Any \bar{F}	All \bar{A} 's	All \bar{B} 's	Add	#1
C _n to C _{n+4} Delay Time	C _n	C _{n+4}	All \bar{A} 's	All \bar{B} 's	Add	#1
Sum _{in} to A = B Delay Time	$\bar{A}0$	A = B	All \bar{B} 's Remaining \bar{A} 's	C _n	Sub	#2
Sum _{in} to Sum _{out} Delay Time (Logic Mode)	$\bar{B}0$	Any \bar{F}	All A's	M	Exclusive OR	#2

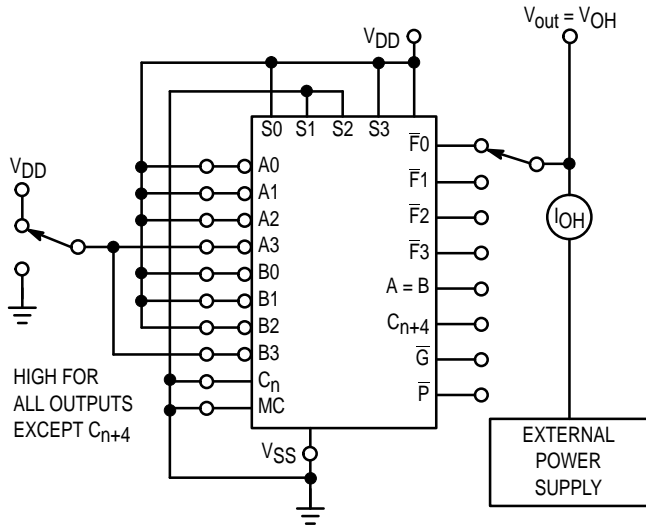

Figure 1. Typical Source Current Test Circuit

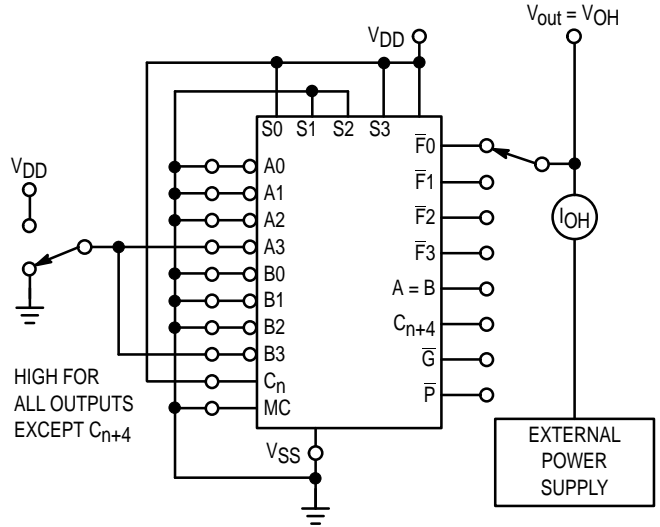

Figure 2. Typical Sink Current Test Circuit

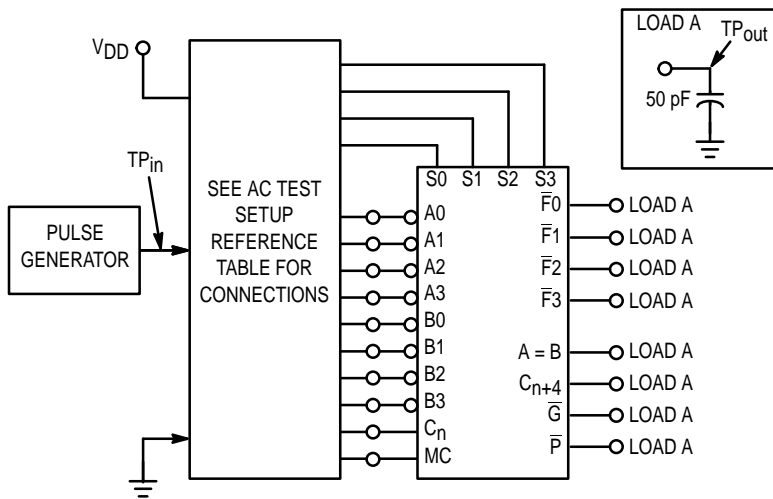

Figure 3. Switching Time Test Circuit and Waveforms

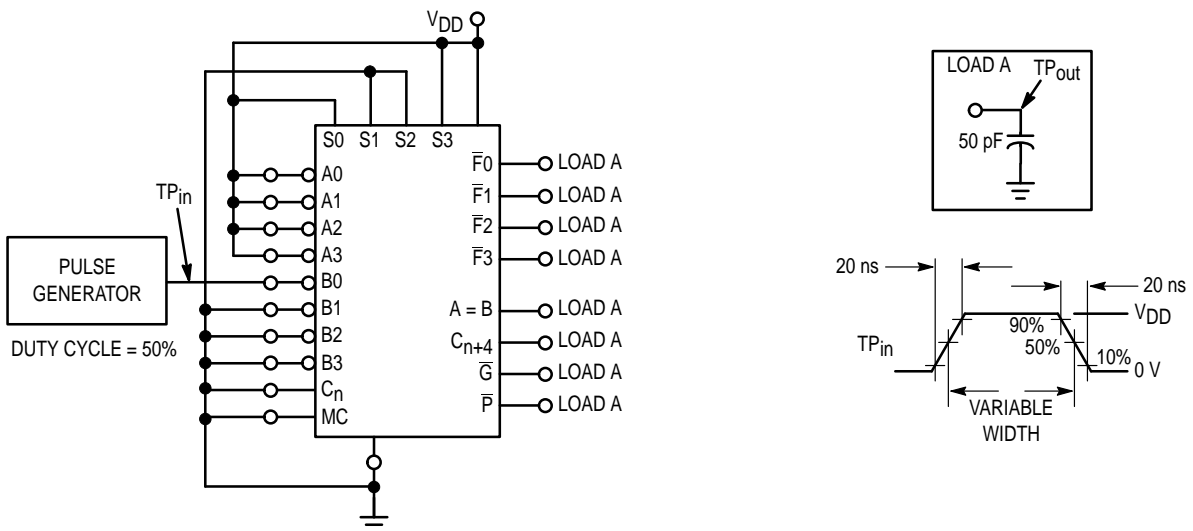
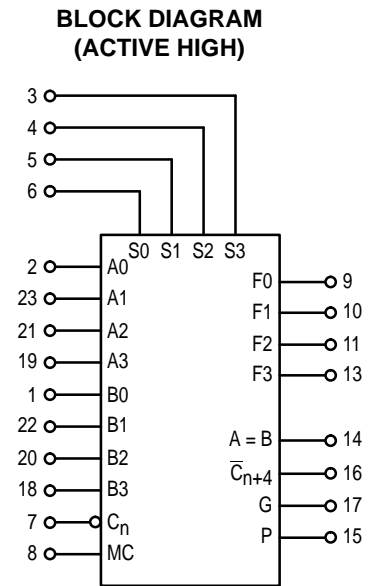
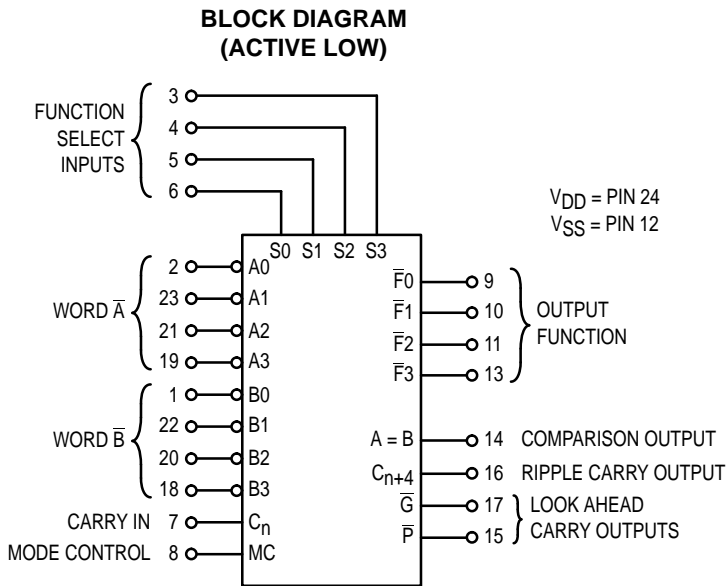

Figure 4. Dynamic Power Dissipation Test Circuit and Waveform



TRUTH TABLE

Function Select				Inputs/Outputs Active Low		Inputs/Outputs Active High	
S3	S2	S1	S0	Logic Function	Arithmetic*	Logic Function	Arithmetic*
				(MC = H)	(MC = L, C _n = L)	(MC = H)	(MC = L, C _n = H)
L	L	L	L	\bar{A}	A minus 1	\bar{A}	A
L	L	L	H	$\bar{A}\bar{B}$	AB minus 1	$\bar{A} + \bar{B}$	A + B
L	L	H	L	$\bar{A} + B$	$A\bar{B}$ minus 1	$\bar{A}B$	A + \bar{B}
L	L	H	H	Logic "1"	minus 1	Logic "0"	minus 1
L	H	L	L	$\bar{A} + \bar{B}$	A plus (A + \bar{B})	$\bar{A}\bar{B}$	A plus $\bar{A}\bar{B}$
L	H	L	H	\bar{B}	AB plus (A + \bar{B})	B	(A + B) plus $\bar{A}\bar{B}$
L	H	H	L	$\bar{A} \oplus \bar{B}$	A minus B minus 1	$A \oplus B$	A minus B minus 1
L	H	H	H	A + \bar{B}	A + \bar{B}	$\bar{A}\bar{B}$	$\bar{A}\bar{B}$ minus 1
H	L	L	L	$\bar{A}B$	A plus (A + B)	$\bar{A} + B$	A plus AB
H	L	L	H	$A \oplus B$	A plus B	$\bar{A} \oplus \bar{B}$	A plus B
H	L	H	L	B	$\bar{A}\bar{B}$ plus (A + B)	B	(A + \bar{B}) plus AB
H	L	H	H	A + B	A + B	AB	AB minus 1
H	H	L	L	Logic "0"	A plus A	Logic "1"	A plus A
H	H	L	H	$\bar{A}\bar{B}$	AB plus A	A + \bar{B}	(A + B) plus A
H	H	H	L	AB	$\bar{A}\bar{B}$ plus A	A + B	(A + \bar{B}) plus A
H	H	H	H	A	A	A	A minus 1

* Expressed as two's complements. For arithmetic function with C_n in the opposite state, the resulting function is as shown plus 1.

OUTLINE DIMENSIONS

L SUFFIX CERAMIC DIP PACKAGE CASE 623-05 ISSUE M

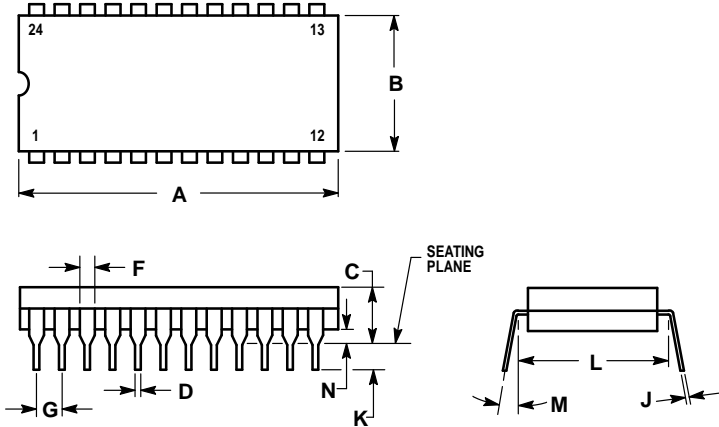

NOTES:

1. DIMENSION L TO CENTER OF LEADS WHEN FORMED PARALLEL.
2. LEADS WITHIN 0.13 (0.005) RADIUS OF TRUE POSITION AT SEATING PLANE AT MAXIMUM MATERIAL CONDITION (WHEN FORMED PARALLEL).

DIM	MILLIMETERS		INCHES	
	MIN	MAX	MIN	MAX
A	31.24	32.77	1.230	1.290
B	12.70	15.49	0.500	0.610
C	4.06	5.59	0.160	0.220
D	0.41	0.51	0.016	0.020
F	1.27	1.52	0.050	0.060
G	2.54 BSC		0.100 BSC	
J	0.20	0.30	0.008	0.012
K	3.18	4.06	0.125	0.160
L	15.24 BSC		0.600 BSC	
M	0°	15°	0°	15°
N	0.51	1.27	0.020	0.050

P SUFFIX PLASTIC DIP PACKAGE CASE 709-02 ISSUE C

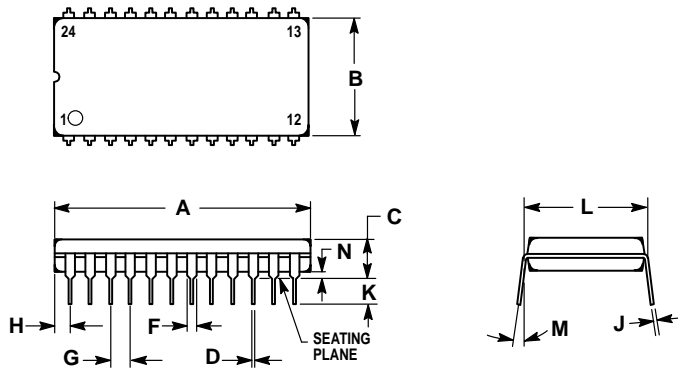

NOTES:

1. POSITIONAL TOLERANCE OF LEADS (D), SHALL BE WITHIN 0.25 (0.010) AT MAXIMUM MATERIAL CONDITION, IN RELATION TO SEATING PLANE AND EACH OTHER.
2. DIMENSION L TO CENTER OF LEADS WHEN FORMED PARALLEL.
3. DIMENSION B DOES NOT INCLUDE MOLD FLASH.

DIM	MILLIMETERS		INCHES	
	MIN	MAX	MIN	MAX
A	31.37	32.13	1.235	1.265
B	13.72	14.22	0.540	0.560
C	3.94	5.08	0.155	0.200
D	0.36	0.56	0.014	0.022
F	1.02	1.52	0.040	0.060
G	2.54 BSC		0.100 BSC	
H	1.65	2.03	0.065	0.080
J	0.20	0.38	0.008	0.015
K	2.92	3.43	0.115	0.135
L	15.24 BSC		0.600 BSC	
M	0°	15°	0°	15°
N	0.51	1.02	0.020	0.040

OUTLINE DIMENSIONS

DW SUFFIX PLASTIC SOIC PACKAGE CASE 751E-04 ISSUE E

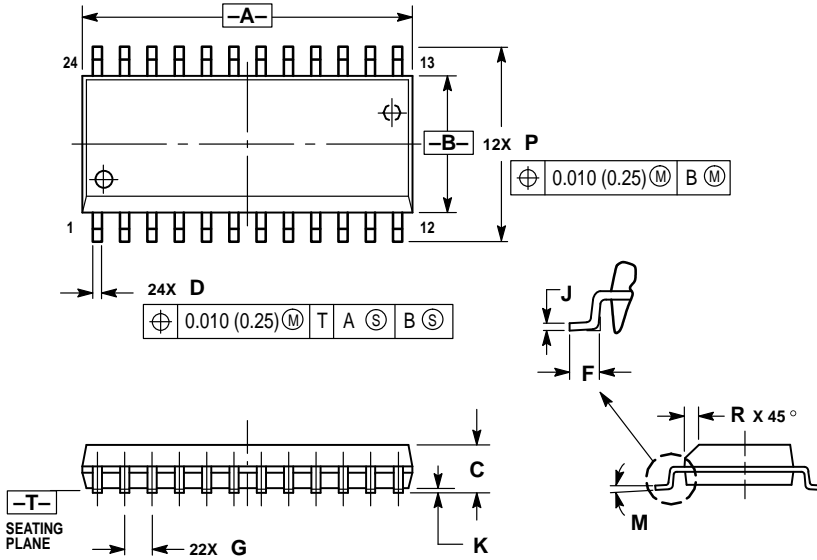

NOTES:

1. DIMENSIONING AND TOLERANCING PER ANSI Y14.5M, 1982.
2. CONTROLLING DIMENSION: MILLIMETER.
3. DIMENSIONS A AND B DO NOT INCLUDE MOLD PROTRUSION.
4. MAXIMUM MOLD PROTRUSION 0.15 (0.006) PER SIDE.
5. DIMENSION D DOES NOT INCLUDE DAMBAR PROTRUSION. ALLOWABLE DAMBAR PROTRUSION SHALL BE 0.13 (0.005) TOTAL IN EXCESS OF D DIMENSION AT MAXIMUM MATERIAL CONDITION.

DIM	MILLIMETERS		INCHES	
	MIN	MAX	MIN	MAX
A	15.25	15.54	0.601	0.612
B	7.40	7.60	0.292	0.299
C	2.35	2.65	0.093	0.104
D	0.35	0.49	0.014	0.019
F	0.41	0.90	0.016	0.035
G	1.27 BSC		0.050 BSC	
J	0.23	0.32	0.009	0.013
K	0.13	0.29	0.005	0.011
M	0°	8°	0°	8°
P	10.05	10.55	0.395	0.415
R	0.25	0.75	0.010	0.029

Motorola reserves the right to make changes without further notice to any products herein. Motorola makes no warranty, representation or guarantee regarding the suitability of its products for any particular purpose, nor does Motorola assume any liability arising out of the application or use of any product or circuit, and specifically disclaims any and all liability, including without limitation consequential or incidental damages. "Typical" parameters which may be provided in Motorola data sheets and/or specifications can and do vary in different applications and actual performance may vary over time. All operating parameters, including "Typicals" must be validated for each customer application by customer's technical experts. Motorola does not convey any license under its patent rights nor the rights of others. Motorola products are not designed, intended, or authorized for use as components in systems intended for surgical implant into the body, or other applications intended to support or sustain life, or for any other application in which the failure of the Motorola product could create a situation where personal injury or death may occur. Should Buyer purchase or use Motorola products for any such unintended or unauthorized application, Buyer shall indemnify and hold Motorola and its officers, employees, subsidiaries, affiliates, and distributors harmless against all claims, costs, damages, and expenses, and reasonable attorney fees arising out of, directly or indirectly, any claim of personal injury or death associated with such unintended or unauthorized use, even if such claim alleges that Motorola was negligent regarding the design or manufacture of the part. Motorola and  are registered trademarks of Motorola, Inc. Motorola, Inc. is an Equal Opportunity/Affirmative Action Employer.

How to reach us:

USA/EUROPE/Locations Not Listed: Motorola Literature Distribution;
P.O. Box 20912; Phoenix, Arizona 85036. 1-800-441-2447 or 602-303-5454

MFAX: RMFAX0@email.sps.mot.com - TOUCHTONE 602-244-6609
INTERNET: <http://Design-NET.com>

JAPAN: Nippon Motorola Ltd.; Tatsumi-SPD-JLDC, 6F Seibu-Butsuryu-Center,
3-14-2 Tatsumi Koto-Ku, Tokyo 135, Japan. 03-81-3521-8315

ASIA/PACIFIC: Motorola Semiconductors H.K. Ltd.; 8B Tai Ping Industrial Park,
51 Ting Kok Road, Tai Po, N.T., Hong Kong. 852-26629298