

NEW PRODUCT

MITSUBISHI <Standard Linear ICs>

M62782GP

VOLTAGE DETECTING, SYSTEM RESETTING IC SERIES

GENERAL DESCRIPTION

The M62782GP is a voltage threshold detector designed for detection of a supply voltage and generation of a system reset pulse for almost all logic circuits such as microprocessor.

It also has extensive applications including battery checking, level detecting and waveform shaping circuits.

FEATURES

- Few external parts
- Low threshold operating voltage (Supply voltage to keep low-state at low supply voltage) ...0.65V(TYP.) at RL=22k
- Wide supply voltage range1.5to 7.0V
- Sudden change in power supply has minimal effect on the ICs
- Wide application range
- Extra small 5-pin package (5-pin SOP) ...SOT-25
- Built-in long delay time 100 ms

APPLICATION

- Reset pulse generation for almost all logic circuits
- Battery checking, level detecting, waveform shaping circuits
- Delayed waveform generator
- Switching circuit to a back-up power supply
- DC/DC converter
- Over voltage protection circuit

RECOMMENDED OPERATING CONDITION

- Supply voltage range 1.5to 7.0V

PIN CONFIGURATION (TOP VIEW)

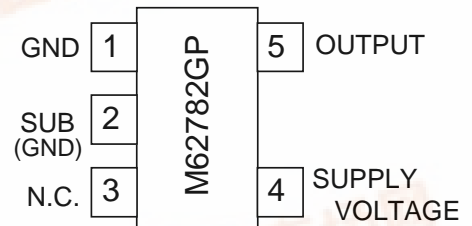

Outline SOT-25

N.C. :NO CONNECTION

BLOCK DIAGRAM

M62782GP

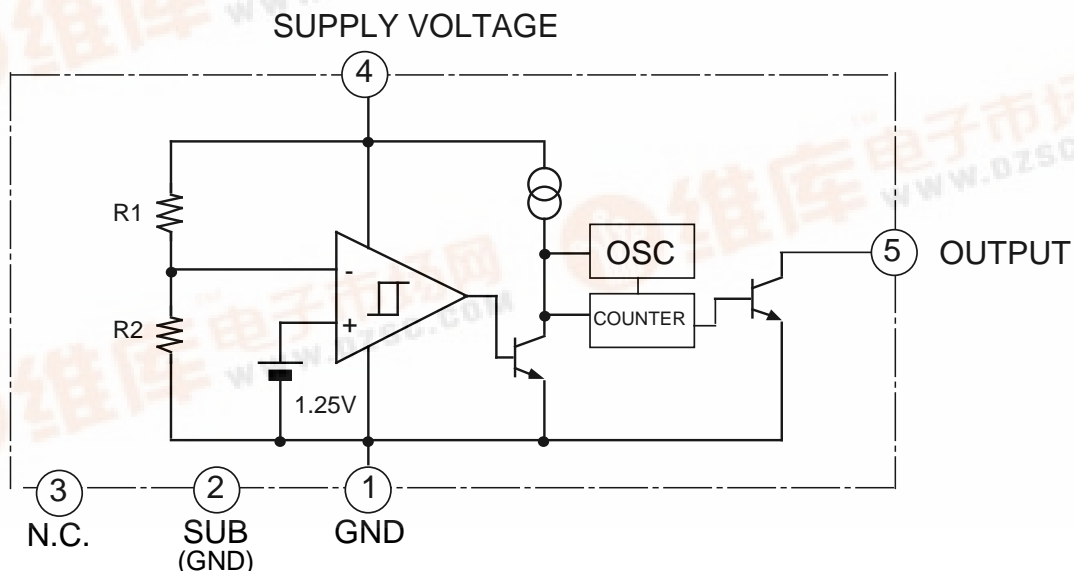

N.C. :NO CONNECTION



M62782GP

VOLTAGE DETECTING, SYSTEM RESETTING IC SERIES

FUNCTION DIAGRAM

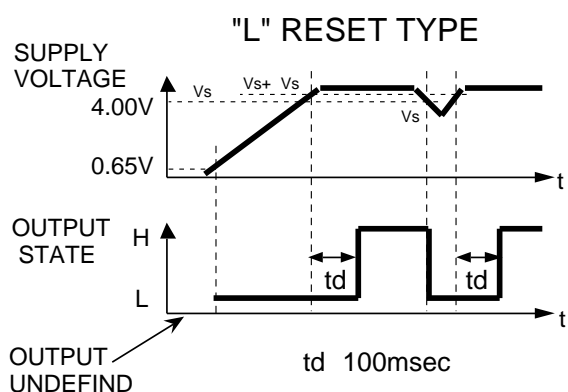

ABSOLUTE MAXIMUM RATINGS (Ta=25°C Unless otherwise noted)

Symbol	Parameter	Test condition	Ratings	Unit
Vcc	Supply Voltage		8	V
Isink	Output Sink Current		6	mA
Vo	Output Voltage	Output with open collector	8	V
Pd	Power Dissipation	3pin SOP(SOT-23)	200	mW
Kθ	Thermal Derating	Ta 25°C	2	mW/°C
Topr	Operating Temperature		-30 to +85	°C
Tstg	Storage Temperature		-40 to +125	°C

ELECTRICAL CHARACTERISTICS (Ta=25°C, Unless otherwise noted)

Symbol	Parameter	Test condition	Limits			Unit	
			MIN	TYP	MAX		
Vs	Detecting Voltage		3.84	4.00	4.16	V	
Vs	Hysteresis Voltage		50	80	110	mV	
Vs/ T	Detecting Voltage Temperature Coefficient		—	0.01	—	%/°C	
Icc	Circuit Current	VCC=5V	—	400	600	μA	
Vsat	Output Saturation Voltage	VCC=3.5V, Isink=4mA	—	0.2	0.4	V	
VOPL	Threshold Operating Voltage	Minimum supply voltage for IC operation	RL=2.2k, Vsat 0.4V	—	0.7	0.8	V
			RL=100k, Vsat 0.4V	—	0.6	0.7	V
IOH	Output Leak Current		—	—	30	nA	
		Ta= -30 to +85 °C	—	—	1	μA	
tPD	Delay Time		60	100	140	ms	

M62782GP

VOLTAGE DETECTING, SYSTEM RESETTING IC SERIES

Example of application circuit Reset Circuit of M62782GP

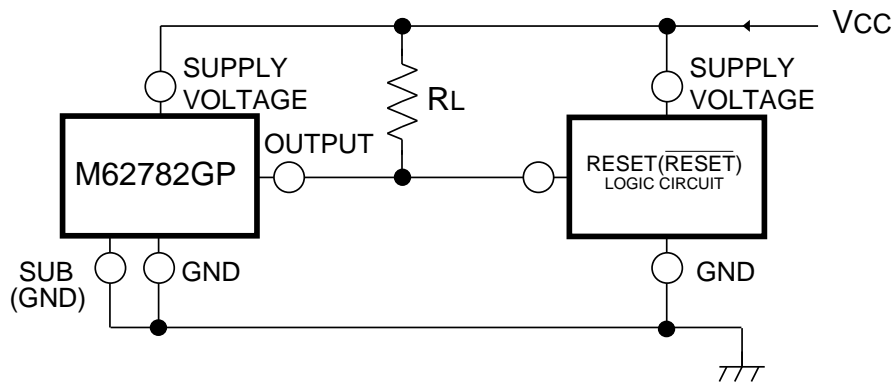

Note 1.

The logic circuit preferably should not have a pull-down resistor, but if one is present, add load resistor RL to overcome the pull-down resistor.

⚠ Mitsubishi Electric Corporation puts the maximum effort into making semiconductor products better and more reliable, but there is always the possibility that trouble may occur with them. Trouble with semiconductors may lead to personal injury, fire or property damage. Remember to give due consideration to safety when making your circuit design, in order to prevent fires from spreading, redundancy, malfunction or other mishap.

MITSUBISHI <Standard Linear ICs>

M62782GP

VOLTAGE DETECTING, SYSTEM RESETTNG IC SERIES

PACKAGE OUTLINE

SOT-25

Dimension : mm

