

Distributed by:

**JAMECO**<sup>®</sup>  
ELECTRONICS

**www.Jameco.com ♦ 1-800-831-4242**

The content and copyrights of the attached  
material are the property of its owner.

Jameco Part Number 802960



# PRODUCT SPECIFICATION

## COMMERCIAL MICRO-D CONNECTOR SYSTEM

### 1.0 SCOPE

This Product Specification covers the 1.27 mm (.050 inch) centerline Commercial Micro-D connector series, including both printed circuit board header connector styles and cable connector series, terminable to 26 or 28 AWG shielded cable

### 2.0 PRODUCT DESCRIPTION

#### 2.1 DIMENSIONS, MATERIALS, PLATINGS AND MARKINGS

##### PRODUCT NAME AND PART NUMBERS

The following product names and series numbers are covered by this specification:

Headers w/wo jackposts, Size 9	Series 83611
Headers w/wo jackposts, Size 15	Series 83612
Headers w/wo jackposts, Size 25	Series 83614
Dual Stack Headers w/wo jackposts	Series 83619
Shielded Cable Connector, Size 9	Series 83421
Shielded Cable Connector, Size 15	Series 83422
Shielded Cable Connector, Size 25	Series 83424

### 2.2

Refer to the associated Sales Drawings for additional information on configurations, dimensions, materials, platings and markings.

#### CONNECTOR CONFIGURATIONS

Connectors and headers are available in a variety of configurations, stamped one-piece pin contacts, and jackpost configurations, which will accept 2-56 or 4-40 threaded jackscrews.

REVISION: <b>L</b>	EGR/ECN INFORMATION: EC No: <b>ETC2005-0180</b> DATE: <b>1997 /10 / 28</b>	TITLE: <b>PRODUCT SPECIFICATION FOR COMMERCIAL MICRO-D CONNECTOR SYSTEM</b>	SHEET No. <b>1 of 15</b>
DOCUMENT NUMBER: <b>PS-83421-9000</b>	CREATED / REVISED BY: <b>A.WILSON</b>	CHECKED BY: <b>A.WILSON</b>	APPROVED BY: <b>F.MALCZYK</b>



# PRODUCT SPECIFICATION

## 2.3 DESIGN FEATURES

### MATERIALS AND PLATINGS

Pin Contacts	15µin min gold over 30µin min nickel in mating area and 20µin min tin over 50µin min nickel on the solder tail. Base material is a copper alloy.
Socket Contacts	15 or 30 µin min gold over 50µin min nickel. Base material is a copper alloy.
Insulators	Injection molded LCP, UL 94V-0
Shells	150µin nickel over alloy steel.
Backshells	100µin nickel over alloy steel with PVC overmold or Optional rubber boot. Color black

### CABLE

Configuration	Max 25 conductors with braided copper shield and with overall jacket.
Outer diameter	0.225-inch nominal      for Size 9 0.264-inch nominal      for Size 15 0.311-inch nominal      for Size 25
Overall jacket	Material optional
Conductors	28 AWG (7 strands of 36 AWG) 26 AWG (7 strands of 34 AWG)

## 2.4 SAFETY AGENCY APPROVAL

The following approvals are applicable to the connectors and cable assemblies covered by this specification:

UL Recognition	UL File Number	E34763
----------------	----------------	--------

<b>REVISION:</b> <b>L</b>	<b>EGR/ECN INFORMATION:</b> EC No: <b>ETC2005-0180</b> DATE: <b>1997 /10 / 28</b>	<b>TITLE:</b> <b>PRODUCT SPECIFICATION FOR COMMERCIAL MICRO-D CONNECTOR SYSTEM</b>	<b>SHEET No.</b> <b>2 of 15</b>
<b>DOCUMENT NUMBER:</b> <b>PS-83421-9000</b>	<b>CREATED / REVISED BY:</b> <b>A.WILSON</b>	<b>CHECKED BY:</b> <b>A.WILSON</b>	<b>APPROVED BY:</b> <b>F.MALCZYK</b>



# PRODUCT SPECIFICATION

## 3.0 APPLICABLE DOCUMENTS AND SPECIFICATIONS

3.1 The connectors and cable assemblies covered by this specification are commercial versions, designed and tested to meet MIL-specification and performance standards and comply with the requirements of the following standards

3.2 MIL-DTL-83513	DETAIL SPECIFICATION—MICRO MINIATURE, RECTANGLAR CONNECTORS
MIL-STD-1344	TEST METHODS FOR ELECTRICAL CONNECTORS
UL 1977	STANDARD FOR SAFETY—COMPONENT CONNECTORS
APPLICATIONS	Used in Data, Signal, Control and Power

## 4.0 RATINGS

### 4.1 ELECTRICAL

DIELECTRIC WITHSTANDING VOLTAGE (DWV)	350Vac
CURRENT RATING	1A at 25 C 77 F, 0.7A at 70 C, 158 F

### 4.2 ENVIRONMENTAL

Shock	half sine, 50g, 11ms duration
Vibration resistance	10-500Hz @ 5g accel
Thermal Cycling	-55°C to +125°C
Contact durability	500 cycles minimum
Contact Engagement Force	0.15N to 2.4N (0.5 oz Min to 8.6 oz Max) per contact.
Shell mating force	5.5 LB max/connector
Contact retention	5.0 lb min per Method 2007 of MIL-STD-1344
HUMIDITY @ 95%	21 DAYS PER METHOD 1002 OF MIL-STD-1344

### 4.2 TEMPERATURE

Operating: -40°C to + 125°C  
 Nonoperating: -55°C to + 85°C

REVISION: <b>L</b>	EGR/ECN INFORMATION: EC No: <b>ETC2005-0180</b> DATE: <b>1997 /10 / 28</b>	TITLE: <b>PRODUCT SPECIFICATION FOR COMMERCIAL MICRO-D CONNECTOR SYSTEM</b>	SHEET No. <b>3 of 15</b>
DOCUMENT NUMBER: <b>PS-83421-9000</b>	CREATED / REVISED BY: <b>A.WILSON</b>	CHECKED BY: <b>A.WILSON</b>	APPROVED BY: <b>F.MALCZYK</b>



# PRODUCT SPECIFICATION

## 5.0 PERFORMANCE

This paragraph defines the tests to be performed, and the sequence in which they are to be performed. Unless otherwise specified, all tests shall be carried out under standard atmospheric conditions for testing. Unless otherwise defined, mated sets of connector parts shall be tested. Care shall be taken to keep a particular combination of connector pairs together during the complete sequence

Before commencing any testing, all specimens shall be stored for at least 24 hours in the non-inserted state (unmated) under normal atmospheric conditions. The following tests, a mated connector pair is called a specimen. When the Initial Tests have been completed, all specimens shall be divided up according to the test groups noted, in the quantities noted.

### 5.1

#### NUMBER OF TEST SPECIMENS

TEST GROUP	TABLE NO.	NO. OF SPECIMEN
INITIAL	I	13
SHOCK & VIB	A	4
MECHANICAL	B	4
HUMIDITY	C	4

**TABLE I: TEST GROUP – INITIAL** \*\* This test must be performed before crimping of backshell

PHASE	TEST	TEST CONDITION	MEASUREMENT	REQMT SPEC.	REQUIREMENT
1	Initial Measurement	Unmated Connectors	Visual		No defects that impair normal operation
1a		Unmated Connectors	Dimensional	Product Drawing	No deviations from dimensional tolerances
2		Unmated Connectors	Polarization	Test force: 5.5 lb max	Connectors shall mate in the correct manner
3	**	Unmated Connectors See Fig. 1	Contact Resistance. MIL-STD-1344 METHOD 3002	20mV max @ 100mA (Kelvin 4-wire test)	C.R.=8mΩ max thru p/s interface & socket crimp
4		Unmated Connectors	Insulation Resistance MIL-STD-1344 METHOD 3002	500 ± 15VDC,	I.R. to be >5 x 10 <sup>9</sup> Ω
5		Unmated Connectors	Voltage proof (DWV) MIL-STD-1344 METHOD 3001, TEST COND I	630 Vac min	No breakdown, flashover, or leakage >1mohm

REVISION: <b>L</b>	EGR/ECN INFORMATION: EC No: <b>ETC2005-0180</b> DATE: <b>1997/10/28</b>	TITLE: <b>PRODUCT SPECIFICATION FOR COMMERCIAL MICRO-D CONNECTOR SYSTEM</b>	SHEET No. <b>4 of 15</b>
DOCUMENT NUMBER: <b>PS-83421-9000</b>	CREATED / REVISED BY: <b>A.WILSON</b>	CHECKED BY: <b>A.WILSON</b>	APPROVED BY: <b>F.MALCZYK</b>



# PRODUCT SPECIFICATION

**5.2 TABLE A: TEST GROUP - SHOCK AND VIBRATION**

PHASE	TEST	TEST CONDITION	MEASURE- MENT	REQMT SPEC.	REQUIREMENT
1		Unmated Connectors See Fig. 2	Gage retention force	4 contacts/ conn.	0.5oz min withdrawal /contact
2		Mated Connectors See Fig. 5	Connector mate/unmate	10mm/sac	6 oz Max mating force/contact +
3	Vibration** MIL-STD- 1344 METHOD 2005, COND II	Freq = 10-500 Hz 5g acceleration Duration = 2hrs/axis Conn. mounting per Fig3	Contact resistance,  Contact	20 mA, 20 mV	Max 15 mOhms change from initial C.R. meas. in Table I. Contact intermittence to be
4	Mechanical Shock** MIL- STD-1344 METHOD 2004	Acceleration = 50 g duration = 11 ms, 10 shocks, 5 in each axis, half sine. Connector mounting per Fig. 3.	Contact resistance  Contact intermittence	100mA, 20mV	Max 15 mOhms chg from init. C.R. meas. in Table I. intermittence <1 microsec. Intermit=
5	Thermal Shock** MIL- STD-1344 METHOD 1003 COND A	Mated connectors. 5 cycles. Temp°C/Dur.min -55+/- 3/30;+25 +/-10 /5; +125+/-3/30; +25+/-10 /5			
6		Unmated connectors	Insulation resistance	Test voltage 500 +/-15V.	I.R. to be >5 x10 <sup>9</sup> Ω
7		Unmated connectors	Withstanding voltage (DWV)	Apply 630 V min	No breakdown, flashover, or leakage >1mohm .
8		Unmated connectors See Fig. 1**	Contact resistance	20mV max @ 100mA (Kelvin 4-wire test)	C.R.=8mΩ max change from initial
9		Unmated connectors	Visual exam		No evidence of damage that will affect performance

\*\* For this test the contact resistance may be measured through the cable, if the bulk resistance of the cable has been accounted for.

REVISION: <b>L</b>	EGR/ECN INFORMATION: EC No: <b>ETC2005-0180</b> DATE: <b>1997 /10 / 28</b>	TITLE: <b>PRODUCT SPECIFICATION FOR COMMERCIAL MICRO-D CONNECTOR SYSTEM</b>	SHEET No. <b>5 of 15</b>
DOCUMENT NUMBER: <b>PS-83421-9000</b>	CREATED / REVISED BY: <b>A.WILSON</b>	CHECKED BY: <b>A.WILSON</b>	APPROVED BY: <b>F.MALCZYK</b>



# PRODUCT SPECIFICATION

## 5.3 TABLE B; TEST GROUP - MECHANICAL CYCLING AND HUMIDITY

PHASE	TEST CONDITION	TEST CONDITION	MEASURE- MENT	REQMT SPEC	REQUIREMENT
1	Durability	Speed 10mm/sec 500 cycles, 30 seconds rest in unmated condition		0.05 min electrical engagement/ cycle	
2		Unmated Connectors	Insulation resistance	Test voltage 500 +/-15V.	I.R. to be $>5 \times 10^9 \Omega$
3		Unmated Connectors	Withstanding voltage (DWV)	630 V min	No breakdown, flashover, or leakage $>1 \text{ mohm}$ .
4		Unmated Connectors See Fig. 1**	Contact resistance	20mV max @100mA (Kelvin 4-wire test)	C.R.= $35 \text{ m}\Omega$ max change from initial
5		Unmated Connectors See Fig. 2	Gage retention force	4 contacts/ conn. See Fig 2	0.5oz min withdrawal /contact
6		Unmated Connectors	Visual exam		No evidence of damage that will affect performance
7	Static Load, axial	Mated Connectors See Fig. 4	Connector pulloff	2 conn/lot. Application rate 2.25lb/sec. Total force 25 lb min	No evidence of damage that will affect performance
8	Cable Retention Cable assy only	Fig. 4 except no jackscrews and anchor clamp to front shell flange	Cable pullout	2 conn/lot. Application rate 2.25lb/ sec. Total force 25 lb min	No evidence of damage that will affect performance
9		Unmated Connectors	Withstanding voltage (DWV)	630 v min	No breakdown, flashover, or leakage $>1 \text{ mohm}$ .

**NOTE: \*\*** For this test the contact resistance may be measured through the cable, if the bulk resistance of the cable has been accounted for

REVISION: <b>L</b>	EGR/ECN INFORMATION: EC No: <b>ETC2005-0180</b> DATE: <b>1997 /10 / 28</b>	TITLE: <b>PRODUCT SPECIFICATION FOR COMMERCIAL MICRO-D CONNECTOR SYSTEM</b>	SHEET No. <b>6 of 15</b>
DOCUMENT NUMBER: <b>PS-83421-9000</b>	CREATED / REVISED BY: <b>A.WILSON</b>	CHECKED BY: <b>A.WILSON</b>	APPROVED BY: <b>F.MALCZYK</b>



# PRODUCT SPECIFICATION

5.4 TABLE C: GROUP - CONTACT RESISTANCE AND HUMIDITY

PHASE	TEST CONDITION	TEST CONDITION	MEASUREMENT	REQMT SPEC.	REQUIREMENT
1	Humidity	Mated Connectors MIL-STD-1344 METHOD 1002, TYPE I COND C		2hr drying time.	
2		Unmated Connectors	Insulation resistance	500 +/-15Vdc	I.R. to be >5 x10 <sup>9</sup> Ω
3		Unmated Connectors	Withstanding voltage (DWV)	630 v min	No breakdown, flashover, or leakage >1 mohm
4		Unmated Connectors See Fig. 1**	Contact resistance	20mV max @100mA (Kelvin 4-wire test)	C.R.=8mΩ max change from initial
5		Unmated Connectors See Fig. 2	Gage retention force	4 contacts/conn. See Fig 2	0.5oz min withdrawal /contact
6		Unmated Connectors	Visual exam		No evidence of damage that will affect performance

**NOTE:** \*\* For this test the contact resistance may be measured through the cable, if the bulk resistance of the cable has been accounted for

REVISION: <b>L</b>	EGR/ECN INFORMATION: EC No: <b>ETC2005-0180</b> DATE: <b>1997 /10 / 28</b>	TITLE: <b>PRODUCT SPECIFICATION FOR COMMERCIAL MICRO-D CONNECTOR SYSTEM</b>	SHEET No. <b>7 of 15</b>
DOCUMENT NUMBER: <b>PS-83421-9000</b>		CREATED / REVISED BY: <b>A.WILSON</b>	CHECKED BY: <b>A.WILSON</b>
		APPROVED BY: <b>F.MALCZYK</b>	





# PRODUCT SPECIFICATION

## 6.0 PACKAGING

Each connector or header shall be packaged to protect against damage during handling, transit and storage.

## 7.0 GAGES AND FIXTURES

### 7.1 CONTACT RESISTANCE MEASUREMENT

Contact resistance measurements shall be made using the test setup shown in Figure 1, and shall meet the performance requirements noted in Para 5.

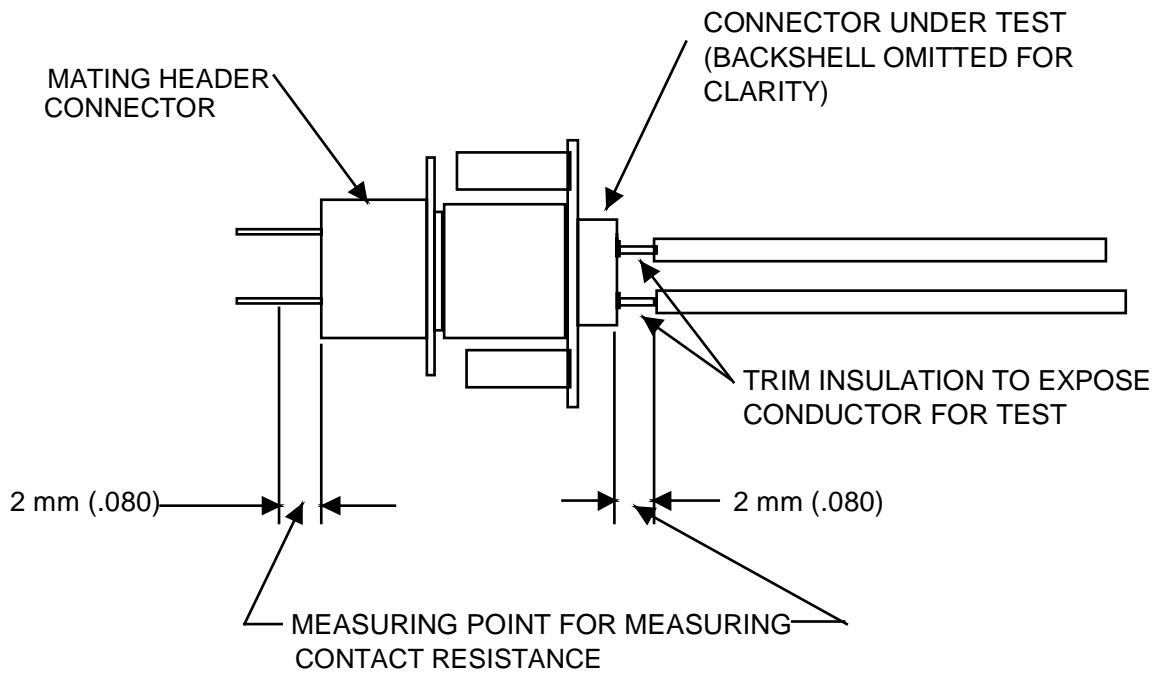

FIGURE 1  
CONTACT RESISTANCE MEASUREMENT

**NOTE:** For this test the contact resistance may be measured through the cable, if the bulk resistance of the cable has been accounted for

REVISION: <b>L</b>	EGR/ECN INFORMATION: EC No: <b>ETC2005-0180</b> DATE: <b>1997 /10 / 28</b>	TITLE: <b>PRODUCT SPECIFICATION FOR COMMERCIAL MICRO-D CONNECTOR SYSTEM</b>	SHEET No. <b>8 of 15</b>
DOCUMENT NUMBER: <b>PS-83421-9000</b>	CREATED / REVISED BY: <b>A.WILSON</b>	CHECKED BY: <b>A.WILSON</b>	APPROVED BY: <b>F.MALCZYK</b>



# PRODUCT SPECIFICATION

## 7.2 CONTACT WITHDRAWAL FORCE MEASUREMENT

Contact withdrawal force measurement shall be made using sizing and test pins as defined below to meet the performance requirements of Para . 5.2.

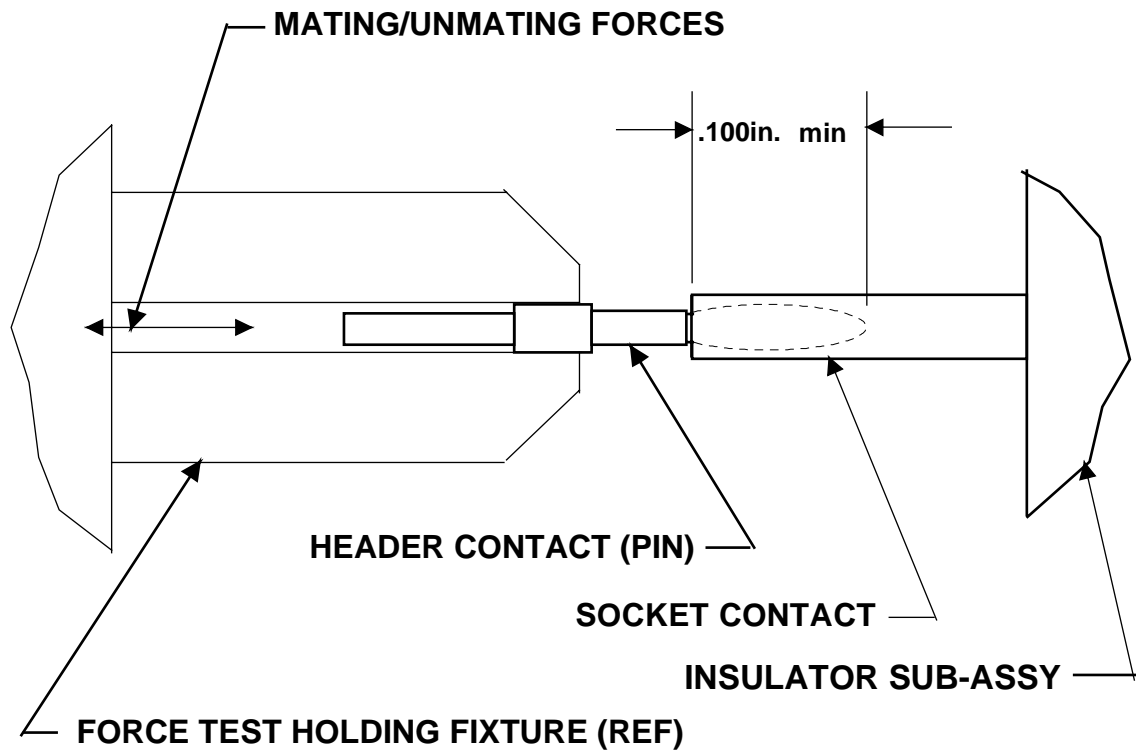

**FIGURE 2**

REVISION: <b>L</b>	EGR/ECN INFORMATION: EC No: <b>ETC2005-0180</b> DATE: <b>1997 /10 / 28</b>	TITLE: <b>PRODUCT SPECIFICATION FOR COMMERCIAL MICRO-D CONNECTOR SYSTEM</b>	SHEET No. <b>9 of 15</b>
DOCUMENT NUMBER: <b>PS-83421-9000</b>	CREATED / REVISED BY: <b>A.WILSON</b>	CHECKED BY: <b>A.WILSON</b>	APPROVED BY: <b>F.MALCZYK</b>



# PRODUCT SPECIFICATION

## 7.3 SHOCK AND VIBRATION TEST SETUP

For shock and vibration testing, connector under test shall be fixtured as shown below

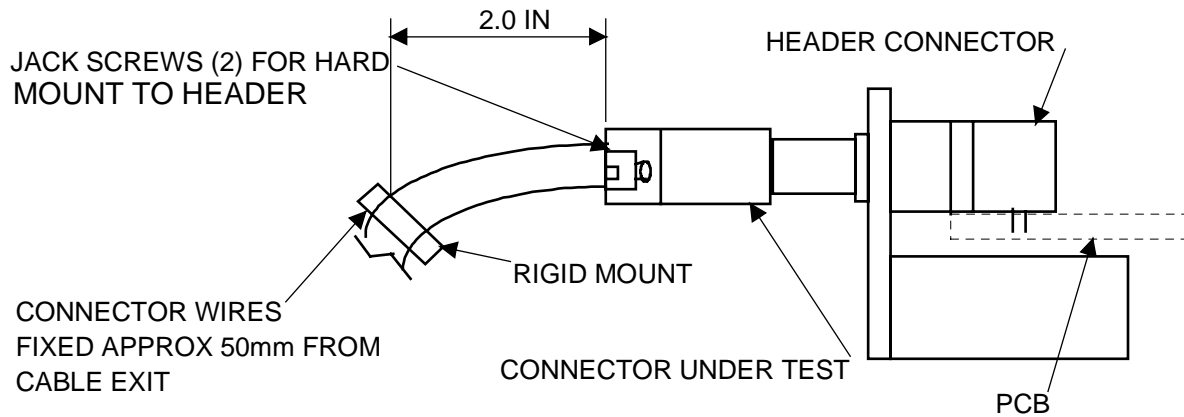

**FIGURE 3**

REVISION: <b>L</b>	EGR/ECN INFORMATION: EC No: <b>ETC2005-0180</b> DATE: <b>1997 /10 / 28</b>	TITLE: <b>PRODUCT SPECIFICATION FOR COMMERCIAL MICRO-D CONNECTOR SYSTEM</b>	SHEET No. <b>10 of 15</b>
DOCUMENT NUMBER: <b>PS-83421-9000</b>	CREATED / REVISED BY: <b>A.WILSON</b>	CHECKED BY: <b>A.WILSON</b>	APPROVED BY: <b>F.MALCZYK</b>



# PRODUCT SPECIFICATION

## 7.4 CABLE PULLOUT TEST REQUIREMENTS

Cable pullout test measurement shall be made using the test setup shown below to meet the requirements of Para. 5.3.

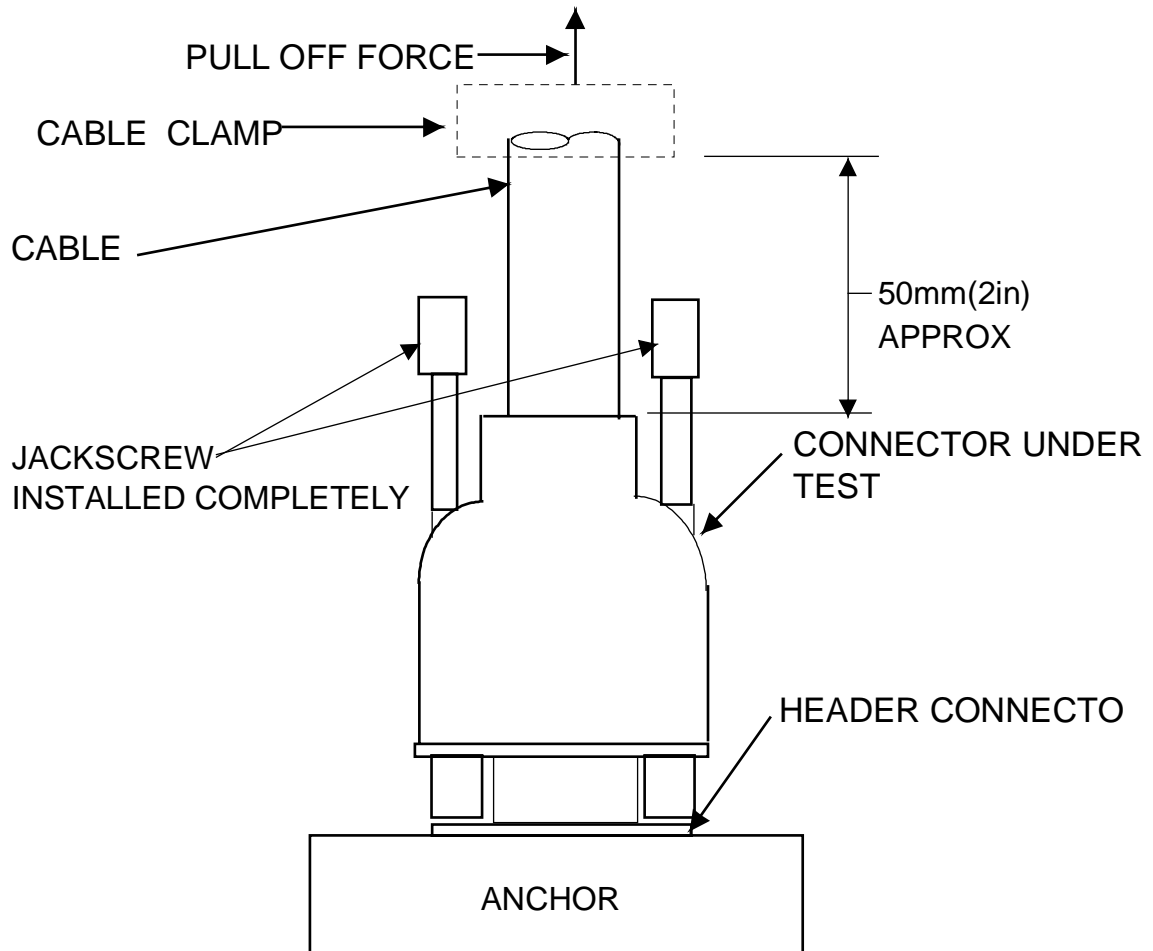

**FIGURE 4**

REVISION: <b>L</b>	EGR/ECN INFORMATION: EC No: <b>ETC2005-0180</b> DATE: <b>1997 /10 / 28</b>	TITLE: <b>PRODUCT SPECIFICATION FOR COMMERCIAL MICRO-D CONNECTOR SYSTEM</b>	SHEET No. <b>11 of 15</b>
DOCUMENT NUMBER: <b>PS-83421-9000</b>	CREATED / REVISED BY: <b>A.WILSON</b>	CHECKED BY: <b>A.WILSON</b>	APPROVED BY: <b>F.MALCZYK</b>



# PRODUCT SPECIFICATION

## 7.5 CONNECTOR MATING AND UNMATING TEST REQUIREMENTS

Connector mating and unmating tests shall be made using the test setup shown below to meet the requirements of Para. 5.2.

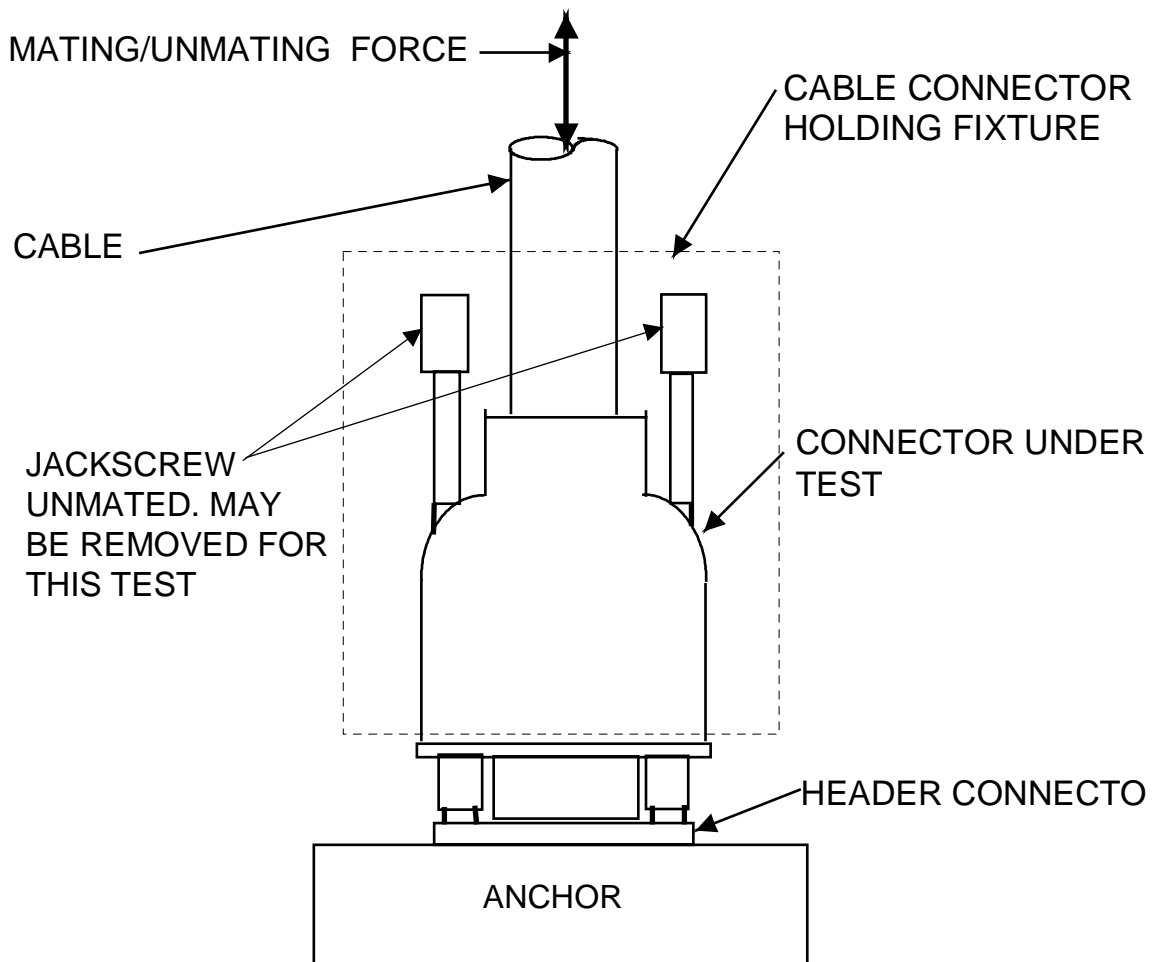

**FIGURE 5**

REVISION: <b>L</b>	EGR/ECN INFORMATION: EC No: <b>ETC2005-0180</b> DATE: <b>1997 /10 / 28</b>	TITLE: <b>PRODUCT SPECIFICATION FOR COMMERCIAL MICRO-D CONNECTOR SYSTEM</b>	SHEET No. <b>12 of 15</b>
DOCUMENT NUMBER: <b>PS-83421-9000</b>	CREATED / REVISED BY: <b>A.WILSON</b>	CHECKED BY: <b>A.WILSON</b>	APPROVED BY: <b>F.MALCZYK</b>



# PRODUCT SPECIFICATION

## 8.0 OTHER INFORMATION

### 8.1 QUALITY CONFORMANCE INSPECTION

Inspection of product for delivery shall consist of Groups A and B inspections.

#### 8.1.1 Group A Inspection

Group A inspection shall consist of the visual and mechanical inspection specified in the table below.

#### GROUP A INSPECTION

INSPECTION	REQUIREMENT	INSPECTION LEVEL
Visual examination	Para. 8.1.1.1	100%
Critical examination	Para. 8.1.1.2	100%

##### 8.1.1.1 Visual examination (Group A inspection)

Each product for delivery shall be visually examined for completeness, workmanship and identification requirements. Attention shall be given to correct material, plating and obvious voids, cracks or other blemishes and defects detrimental to the function of the parts.

##### 8.1.1.2 Critical examination (Group A inspection)

Each product for delivery shall be examined for critical (major) attributes per the individual drawing. These critical attributes shall be examined 100% for conformance to the requirements of the drawing.

Insulator subassemblies and backshell subassemblies shall also be examined for conformance to the subassembly drawings to insure the following (in-process inspection is acceptable):

1. Insulator subassembly latches are completely latched and there is no evidence of cracked, bent or broken latches
2. The two insulators are seated flush with no visible gap between their mating surfaces as a result of excessive flash or debris.
3. Backshell subassemblies shall be free to swivel 360 degrees without distortion of the subassembly components.

REVISION: <b>L</b>	EGR/ECN INFORMATION: EC No: <b>ETC2005-0180</b> DATE: <b>1997 /10 / 28</b>	TITLE: <b>PRODUCT SPECIFICATION FOR COMMERCIAL MICRO-D CONNECTOR SYSTEM</b>	SHEET No. <b>13 of 15</b>
DOCUMENT NUMBER: <b>PS-83421-9000</b>	CREATED / REVISED BY: <b>A.WILSON</b>	CHECKED BY: <b>A.WILSON</b>	APPROVED BY: <b>F.MALCZYK</b>



# PRODUCT SPECIFICATION

## 8.1.2 Group B inspection

Group B inspection shall consist of the inspections specified in the table below, in the order shown, and shall be made on samples that have been submitted and have passed the Group A inspection. Cable assembly samples shall be assembled into single or double-ended cable assemblies of sufficient length to perform the tests noted below.

### GROUP B INSPECTION

INSPECTION	REQUIREMENT	INSPECTION LEVEL
Contact resistance	4 contacts per assy. C.R.=35mΩ max. See Fig 1 for measurement points	AQL 1.0 LEVEL II
Insulation resistance	500±15Vac, 4 contacts per connector.I.R. to be >10 <sup>9</sup> Ω	AQL 1.0 LEVEL II
Dielectric Withstanding Voltage (DWV)	630 Vac min between pins. There shall be no evidence of breakdown or flashover.	AQL 1.0 LEVEL II
Connector mating and unmating force	6.0 oz max mating force/contact x #contacts. +5.5 lb max mating. 0.5 oz min unmating force/contact x # contacts. +1.0 lb min unmating. See Fig 5 for test setup.	AQL 1.0 LEVEL II
Cable retention	25 lb min, See Para. 5.3 for test setup	AQL 1.0 LEVEL II

### 8.2.1.1 Contact resistance (Group B inspection)

Sample connectors from Group A inspection shall be assembled according to sales drawing assembly procedures using 83000-0002 or 83000-0069 contacts. Contacts to be conditioned 3 times using 83000-9001 contact. Contact resistance to be measured using a new not previously mated 83000-9001 contact per MIL-STD-1344, Method 3004 and Figure 1. Backshell sub-assy, boot, crimp ring and jack screws may be omitted. The 83000-9001 contacts used for conditioning are limited to 50 conditioning mates before being replaced.

REVISION: <b>L</b>	EGR/ECN INFORMATION: EC No: <b>ETC2005-0180</b> DATE: <b>1997 /10 / 28</b>	TITLE: <b>PRODUCT SPECIFICATION FOR COMMERCIAL MICRO-D CONNECTOR SYSTEM</b>	SHEET No. <b>14 of 15</b>
DOCUMENT NUMBER: <b>PS-83421-9000</b>	CREATED / REVISED BY: <b>A.WILSON</b>	CHECKED BY: <b>A.WILSON</b>	APPROVED BY: <b>F.MALCZYK</b>



# PRODUCT SPECIFICATION

## 8.2.1.2 Insulation resistance (Group B inspection)

Insulation resistance shall be measured on samples from Para. 8.2.1.1 according to method 3003 of MIL-STD-1344 on each contact in the connector under test. IR to be measured between closest pair of contacts and closest contact and connector shell.

## 8.2.1.3 Dielectric Withstanding Voltage (DWV): (Group B inspection)

DWV shall be measured on samples from Para. 8.2.1.2 according to Method 3001 of MIL-STD-1344 on each contact in the connector under test. DWV to be measured between closest pair of contacts and closest contact and connector shell.

## 8.2.1.4 Connector mating and unmating force (Group B inspection)

Samples from Para 8.2.1.3 shall be assembled with backshell, crimp ring, boot and jackscrews according to sales drawing assembly instructions. Mount connector in pull test fixture as shown in Figure 5 (unmated). At a feed rate of approximately 10mm/sec, mate connector under test with the mating Series 83611, 83612, or 83614 headers as appropriate until fully mated. At the same feed rate, unmate the connector from the header. Monitor mating and unmating forces continuously during mate/unmate cycle.

## 8.2.1.5 Cable retention (Group B inspection)

Samples from Para 8.2.1.4 shall be mounted as shown in Para 5.2, Phase 8. At a rate of approximately 10 mm/sec pull on the cable to 25 lb. minimum. The cable shall not separate from the connector sufficient to affect the performance of the connector.

## 9.0 Revision History

- A. See History file
- B. See History file
- C. See History file
- D. Para. 2.2 and 2.4: deleted ref to specific cable and SSA standards, Para 3.0: Added MIL-STD-1344, Para 4.3, Vibration resistance: was "10-32Hz @ .35amp; 32-500Hz @ 5g accel", TABLES I, A, B, C: corrected Requirements for Contact resistance and Voltage proof; TABLE A: changed Vibration test to Cond II, 10-500 Hz 5g accel; GROUP B INSPECTION: changed DWV to 350 Vac and 630Vac.
- E Revised mate/ummate force to 10 oz per contact
- F Updated product specification to include requirements and parameters for 15 and 25 pin configurations.
- G Added Safety Agency file number and minor editorial corrections.
- H Release to work manager
- J Added 26 AWG cable
- K Added new P/Ns-Overmold, Revised insulator from LCP to Zenite
- L Revised Format

REVISION: <b>L</b>	EGR/ECN INFORMATION: EC No: <b>ETC2005-0180</b> DATE: <b>1997 /10 / 28</b>	TITLE: <b>PRODUCT SPECIFICATION FOR COMMERCIAL MICRO-D CONNECTOR SYSTEM</b>	SHEET No. <b>15 of 15</b>
DOCUMENT NUMBER: <b>PS-83421-9000</b>	CREATED / REVISED BY: <b>A.WILSON</b>	CHECKED BY: <b>A.WILSON</b>	APPROVED BY: <b>F.MALCZYK</b>



MATERIAL NUMBER	ENGINEERING NUMBER
834219101	83421-9101

### CONNECTOR ASSEMBLY INSTRUCTIONS

- ① SLIDE BOOT OVER CABLE.
- ② SLIDE CRIMP RING OVER CABLE.  
BRAIDED SHIELD FOLDS BACK OVER CRIMP RING.
- ③ STRIP CABLE PER STRIPPING INSTRUCTIONS.(SH 1&2)
- ④ CRIMP CONTACTS PER CRIMP INSTRUCTIONS,(SH2).  
SEE CRIMP SPEC 638207800 FOR FINE ADJUST APPLICATOR.  
SEE CRIMP SPEC 638111400 FOR HAND TOOL.
- ⑤ INSERT CONTACTS INTO BACK OF REAR INSULATOR USING NEEDLE NOSE PLIERS WITH A 3/64in/1MM TIP  
PUSH CONTACT INTO REAR INSULATOR UNTIL "WINGS" ON CONTACT SNAP OPEN.  
CONTACT SHOULD NOT EXTEND BEYOND THE BACK OF INSULATOR  
PLACE FRONT INSULATOR ONTO REAR INSULATOR ASSURING PROPER ALLIGNMENT OF CONTACTS.  
CONTINUE TO PUSH UNTIL FRONT AND REAR INSULATOR SNAP TOGETHER.
- ⑥ MOUNT INSULATOR SUBASSEMBLY IN BACKSHELL SUBASSEMBLY PER ASSY INSTRUCTION.(SH 2)
- ⑦ CLOSE BACKSHELL SUBASSEMBLY AROUND CABLE SHIELD PER INSTRUCTIONS.(SH 2)
- ⑧ CRIMP BACKSHELL TO METAL BRAID PER INSTRUCTIONS.(SH 2)
- ⑨ SLIDE BOOT OVER BACKSHELL SUBASSEMBLY
- ⑩ INSERT JACKSCREWS INTO BOOT

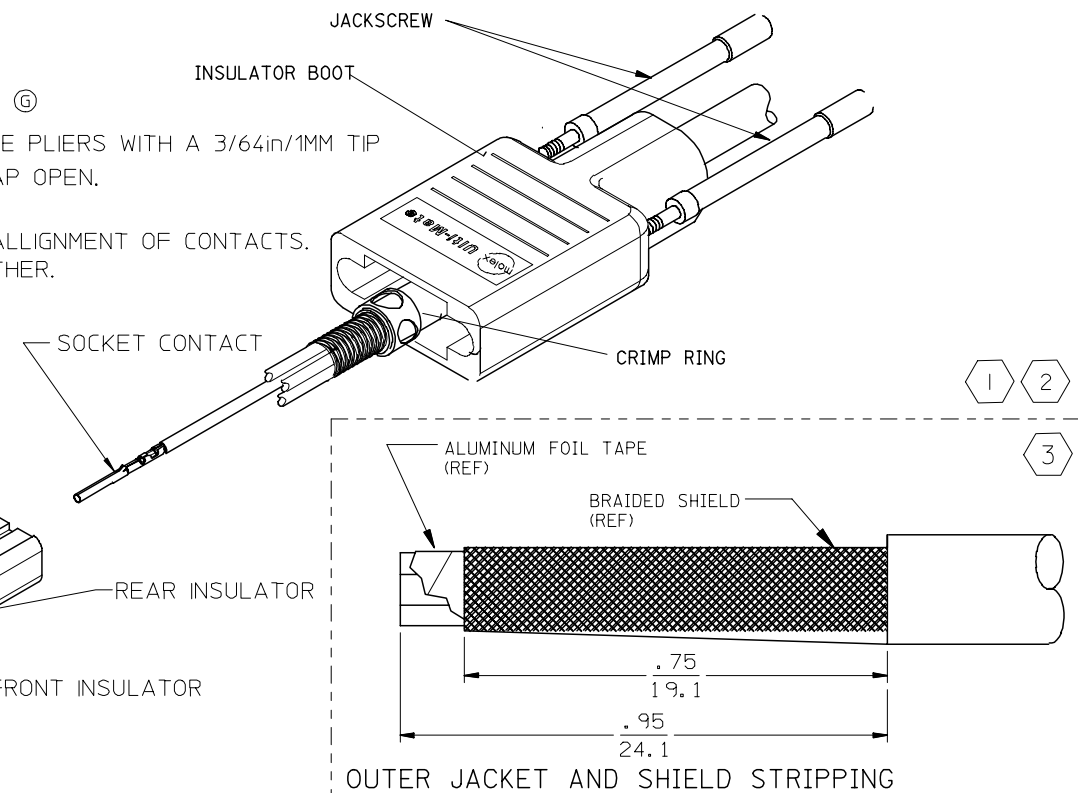

9-POSITION SHOWN

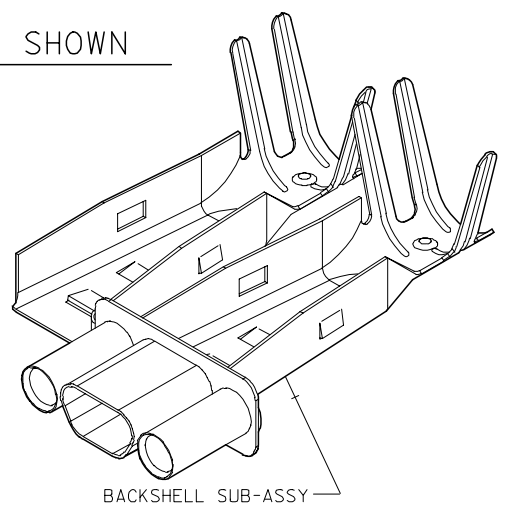

<b>REVISED NOTES</b> EC NO: ETC2005-0132 DRWN: JLOMASTR 2005/02/02 CHKD: 2005/02/02 APPR: RDEROSS 2005/02/02	QUALITY SYMBOLS ▽=0 ▽=0	GENERAL TOLERANCES (UNLESS SPECIFIED) mm INCH 4 PLACES ± --- ± --- 3 PLACES ± --- ± .005 2 PLACES ± 0.13 ± .01 1 PLACE ± 0.25 ± --- ANGULAR ± 1/2°	DIMENSION STYLE IN/MM	SCALE INCH	DESIGN UNITS INCH	THIRD ANGLE PROJECTION
	DRAWN BY JLOMASTR	DATE 05/01/26	TITLE ASSEMBLY INSTRUCTIONS COMMERCIAL MICRO D CONNECTOR			
	CHECKED BY RDEROSS	DATE 05/02/02	MOLEX INCORPORATED			
	APPROVED BY RDEROSS	DATE 05/02/04	MATERIAL NO. SEE CHART	DOCUMENT NO. SD-83421-006	SHEET NO. 1 OF 2	

THIS DRAWING CONTAINS INFORMATION THAT IS PROPRIETARY TO MOLEX INCORPORATED AND SHOULD NOT BE USED WITHOUT WRITTEN PERMISSION

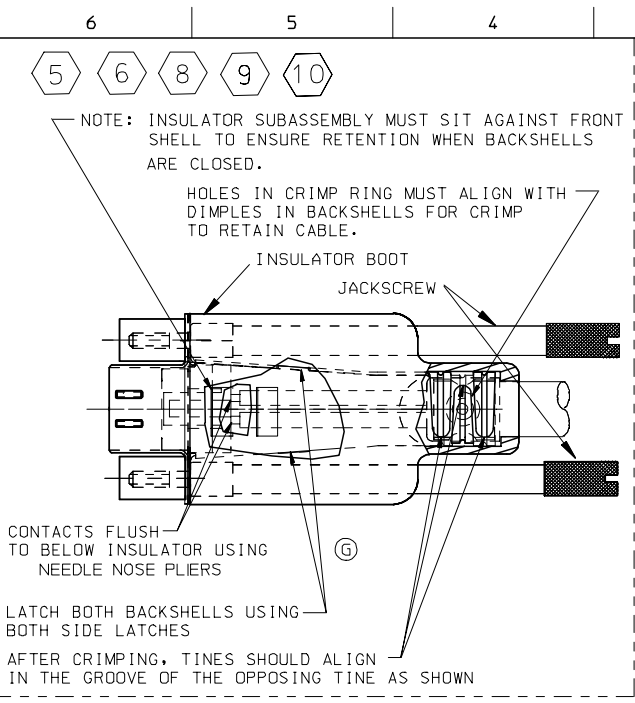
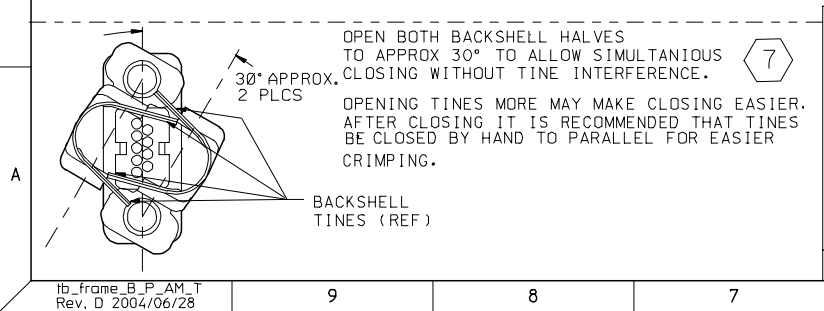
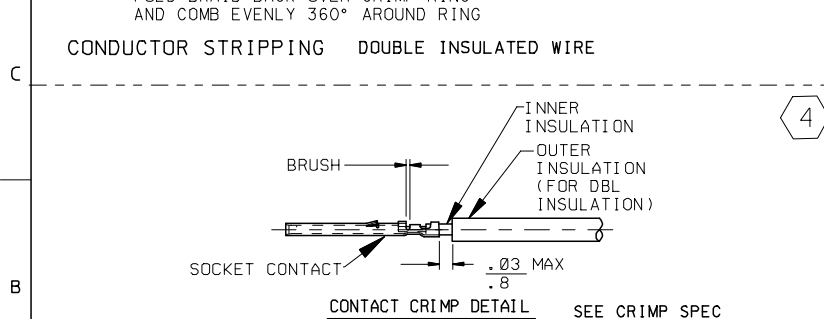
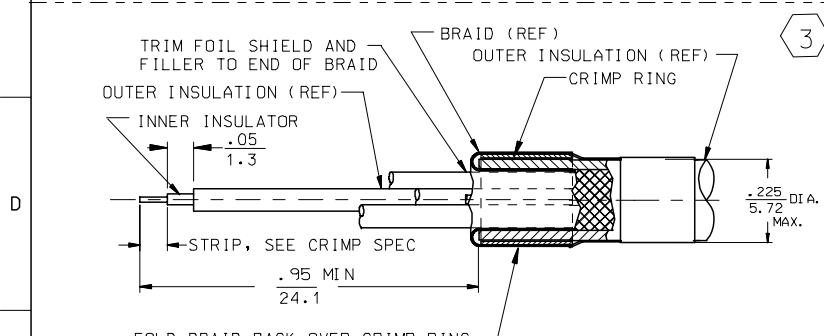
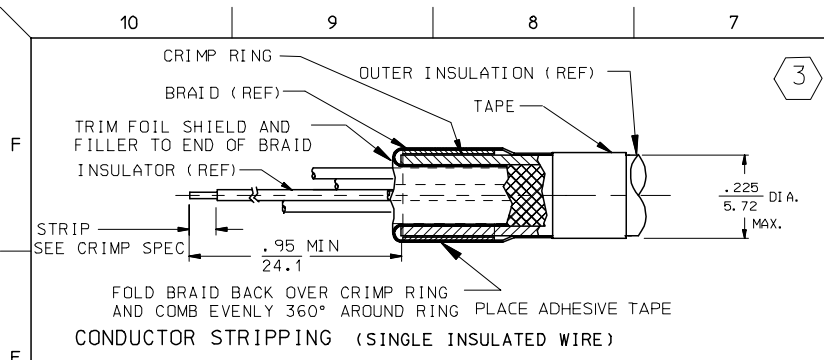

SIZE	DIM A (inch/mm)
9	.320/8.13
15	.370/9.40
25	.420/10.67

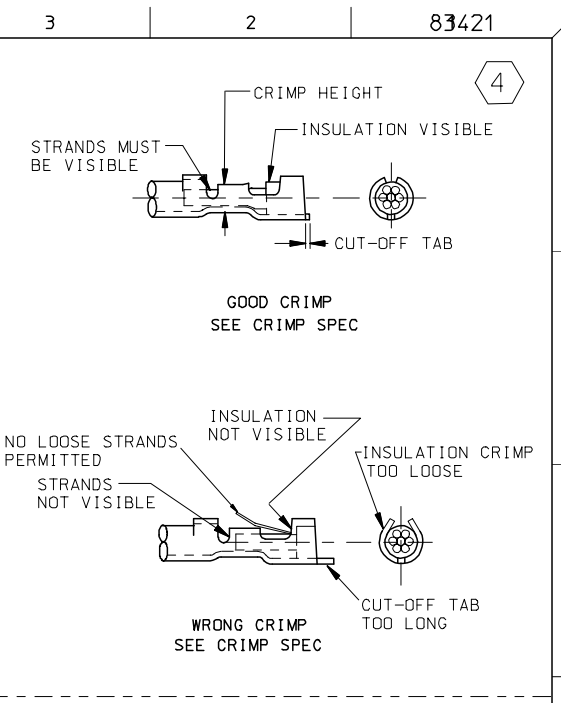
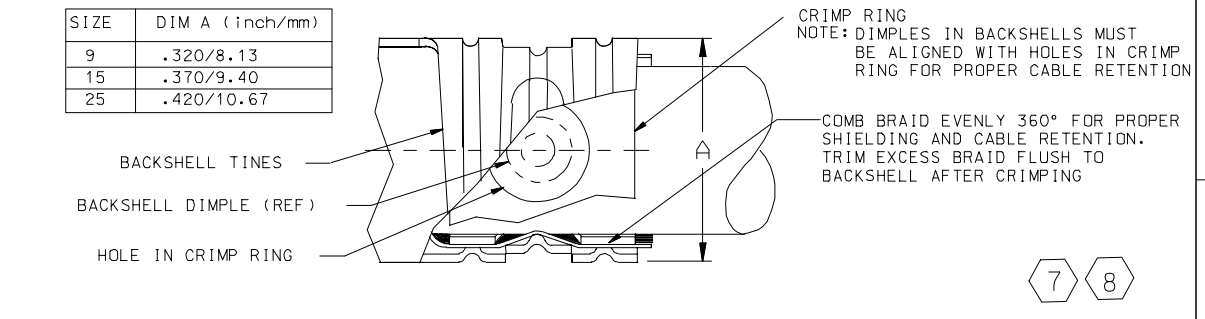

<b>REVISED NOTES</b> EC NO: ETC2005-0132 DRWN: JLOMASTRO 2005/02/02 CHKD: 2005/02/02 APPR: RDEROSS 2005/02/02	QUALITY SYMBOLS ▽=0 ▽=0	GENERAL TOLERANCES (UNLESS SPECIFIED)		DIMENSION STYLE IN/MM		SCALE 1:1	DESIGN UNITS INCH	THIRD ANGLE PROJECTION			
		4 PLACES ± --- ± ---	3 PLACES ± --- ± .005	DRAWN BY JLOMASTRO	DATE 05/01/26	ASSEMBLY INSTRUCTIONS COMMERCIAL MICRO D CONNECTOR					
		2 PLACES ± 0.13 ± .01	1 PLACE ± 0.25 ± ---	CHECKED BY RDEROSS	DATE 05/02/02						
		ANGULAR ± 1/2°		DRAFT WHERE APPLICABLE MUST REMAIN WITHIN DIMENSIONS		APPROVED BY REDORSS	DATE 05/02/04	MOLEX INCORPORATED			
MATERIAL NO. SEE CHART				DOCUMENT NO. SD-83421-006		SHEET NO. 2 OF 2		THIS DRAWING CONTAINS INFORMATION THAT IS PROPRIETARY TO MOLEX INCORPORATED AND SHOULD NOT BE USED WITHOUT WRITTEN PERMISSION			

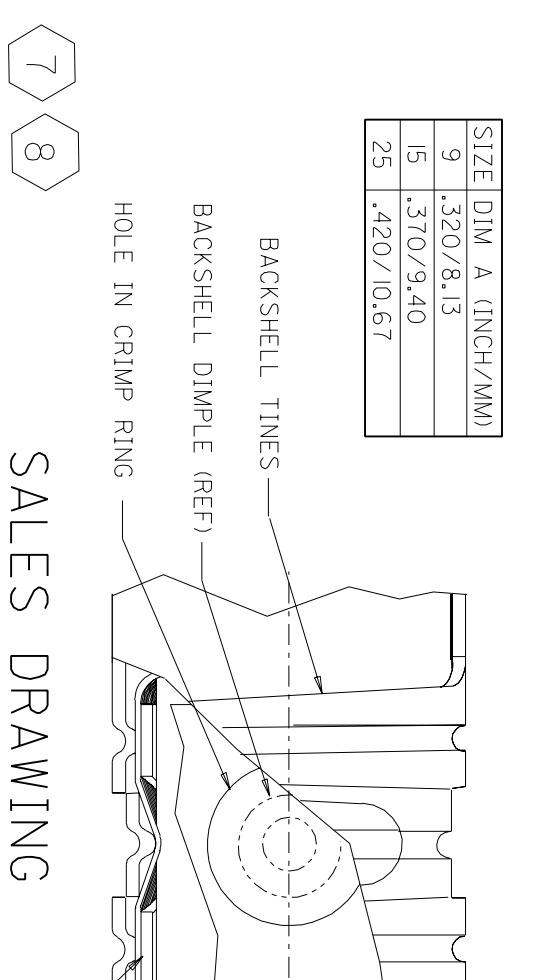
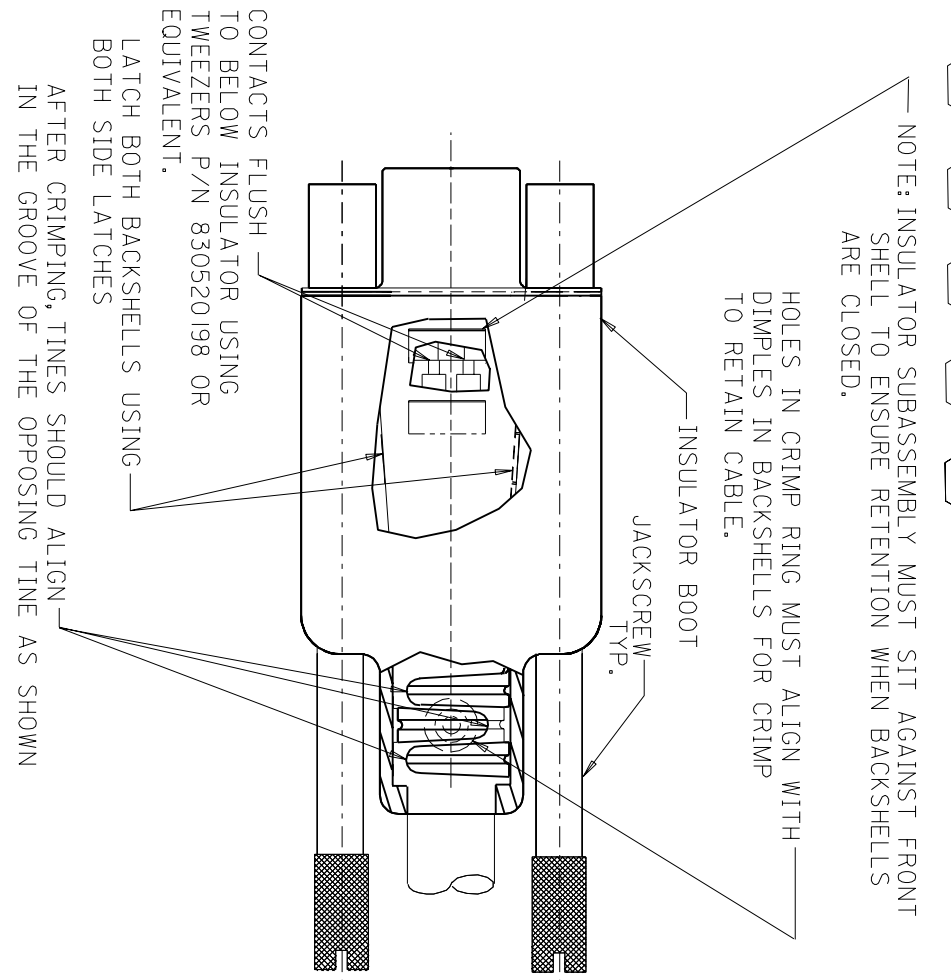
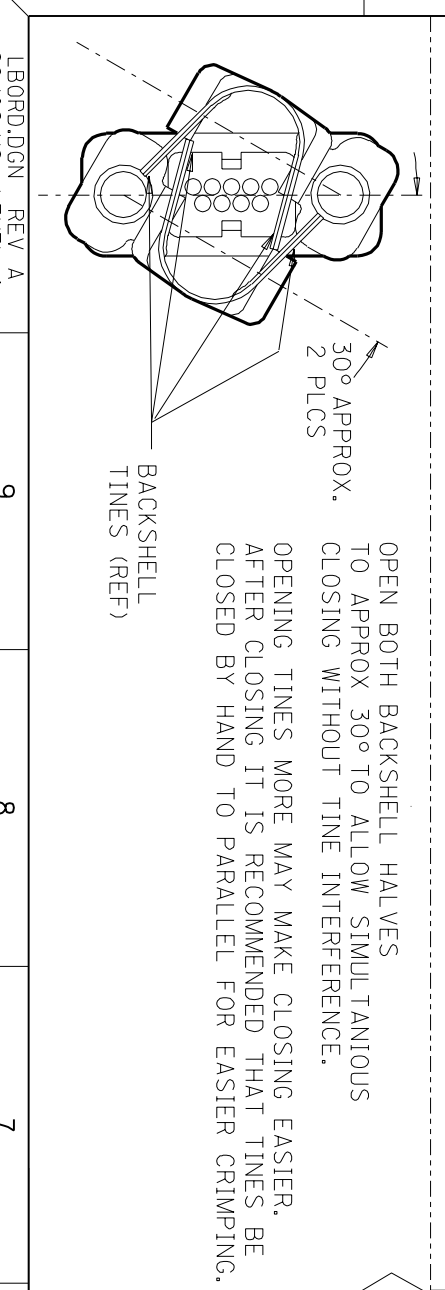
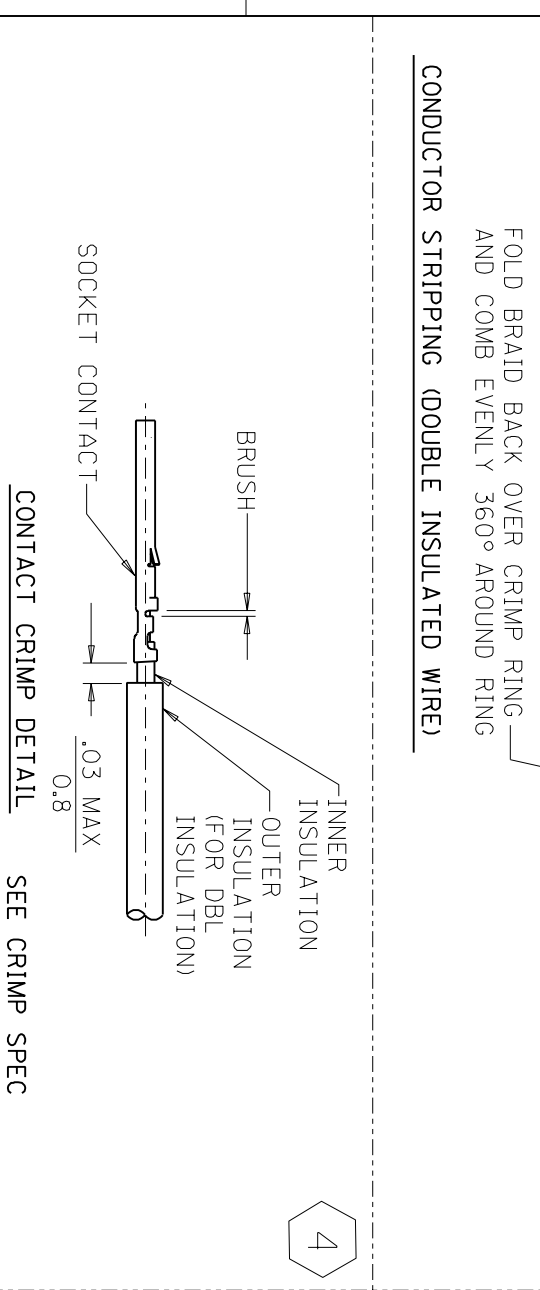
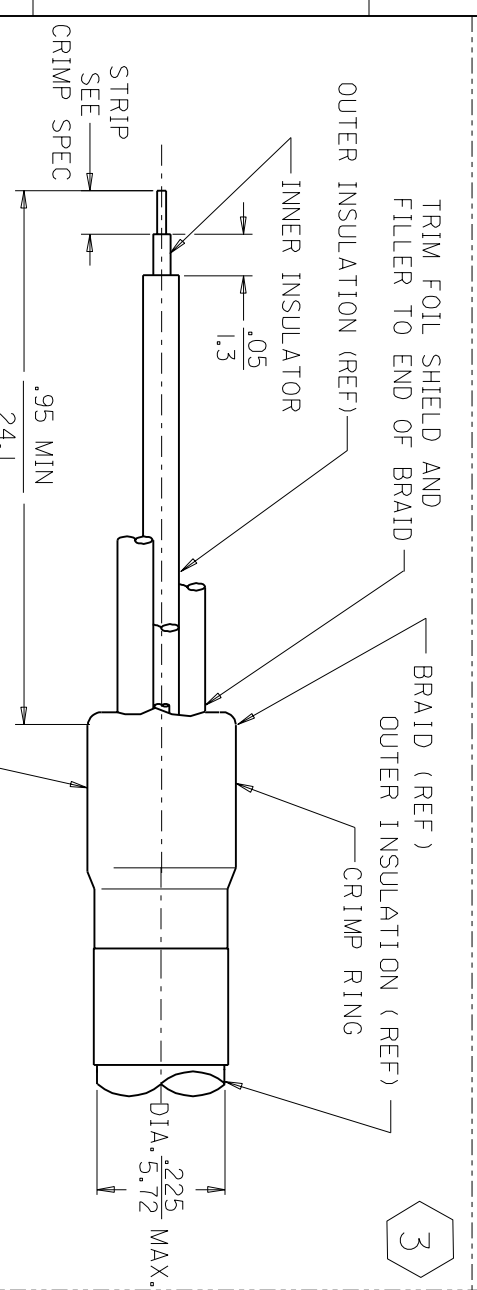
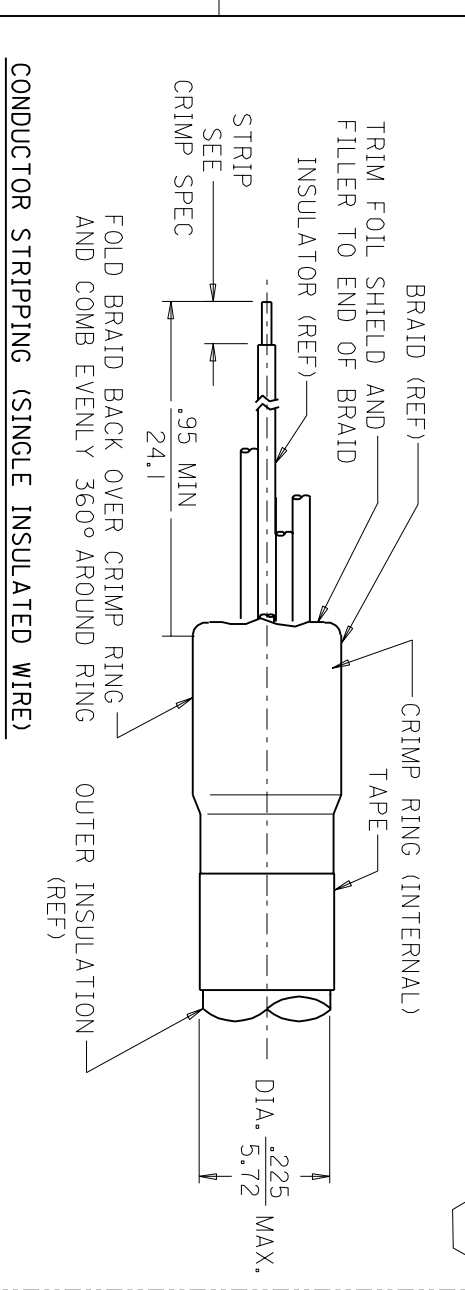

SIZE	DIM A (INCH/MM)
9	.320/8.13
15	.370/9.40
25	.420/10.67

SALES DRAWING

REL. TO W. MANAGER  
EC NO. ETCN002-0300  
DRWN: DLM 02/05/03  
CHK: JL 02/05/03  
APPR: RWD 02/05/03

REV	DESCRIPTION	QUALITY SYMBOLS	GENERAL TOLERANCES: (UNLESS SPECIFIED)	SCALE	DESIGN UNITS	TITLE
A		MAJOR = ∅ CRITICAL = ∅	MM INCH 1 PLACES ±0.25 2 PLACES ±0.13 3 PLACES ±0.10 4 PLACES ±0.05	NTS	mm INCH	ASSEMBLY INSTRUCTIONS COMMERCIAL MICRO-D CONNECTOR

CAD FILENAME: SD83421006.S02 (SEE CHART)  
APPROVED BY & DATE: RWD 02/05/03  
MATERIAL NO.: MOLEX INCORPORATED  
DRAWING NO.: SD-83421-006  
SHEET NO.: 2 OF 2

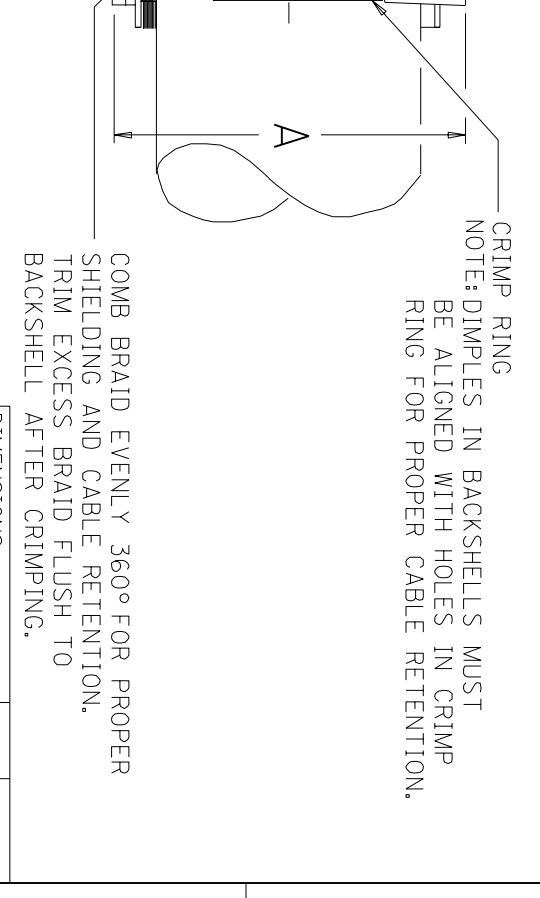
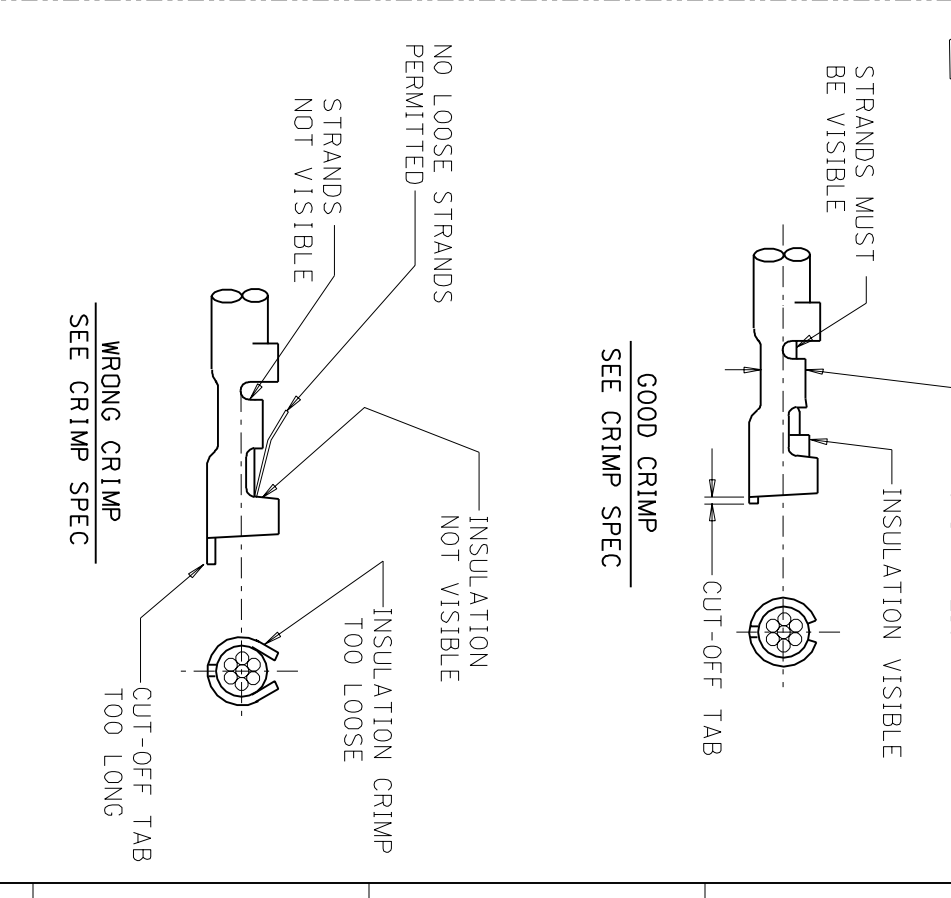

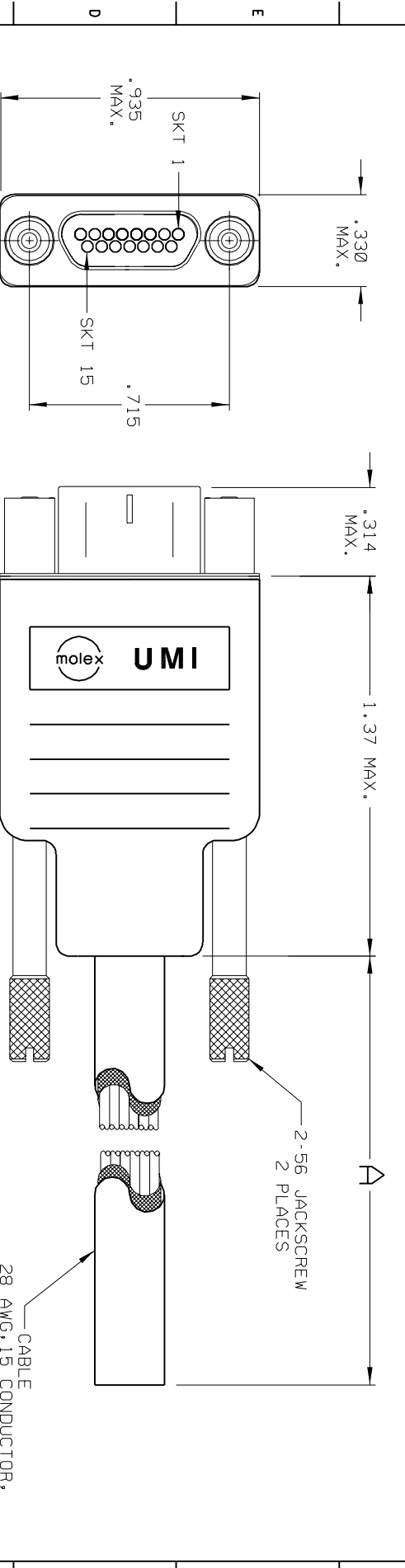
PART NUMBER	A * .5
834229016	4.5
834229007	18.5
834229013	36.5
834229017	48.5
834229018	72.5

1	( )	BLK
2	( )	BRN
3	( )	RED
4	( )	ORG
5	( )	YEL
6	( )	GRN
7	( )	BLU
8	( )	VIO
9	( )	GRY
10	( )	WHT
11	( )	W/BLK
12	( )	W/BRN
13	( )	W/RED
14	( )	W/ORG
15	( )	W/YEL
SHELL	( )	

1. MARKING: NONE.

NOTES: UNLESS OTHERWISE SPECIFIED,

LEBRODSON REV A 59/06/12 LEVEL 11

QUALITY SYMBOLS	UNLESS SPECIFIED, ALL DIMENSIONS IN INCHES	SCALE	DWG SIZE	THIRD ANGLE PROJECTION	REVISE ON CAD ONLY
MAJOR = ∅	GENERAL TOLERANCES:	NONE	B	∅	
CRITICAL C = ∅	3 PLACES * .005	DRAWN BY & DATE			
	2 PLACES * .01	CHECKED BY & DATE			
	ANGULAR * 2.	F. VAN WYK			
UMI-More CAGE CODE		APPROVED BY & DATE			
58967					

TITLE: CABLE ASSEMBLY, COMMER-D, SIZE 15, RECP T. 18.0

PART NO. MOLEX INCORPORATED 92868

SEE "TAB BLOCK" DRAWING NO. OF 0909, CA 1 OF 1

SD-83422-9007

REV C